

10SM1000 SWIRLMETER

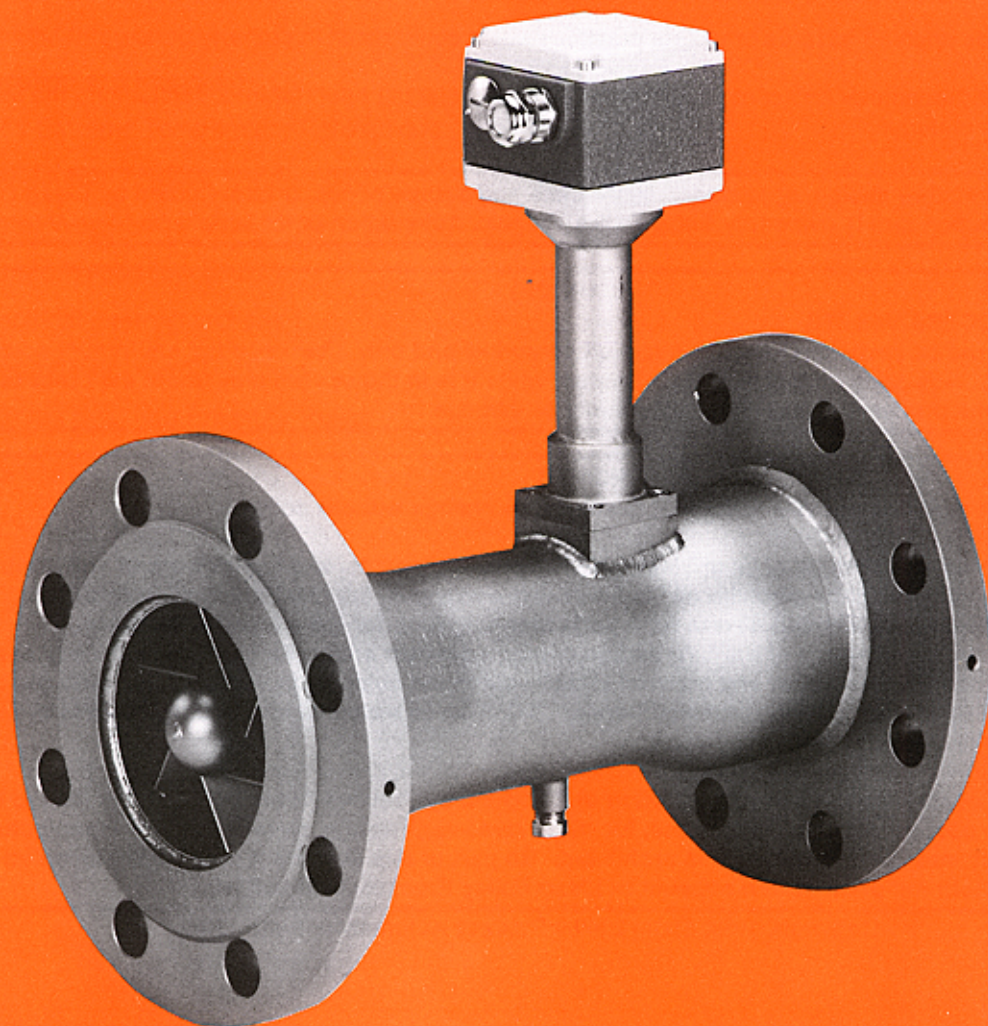

The following are registered trademarks of Du Pont:

TEFLON®
VITON®

The following is a registered trademark of HART Communication Foundation:

HART®

WARNING notices as used in this manual apply to hazards or unsafe practices which could result in personal injury or death.

CAUTION notices apply to hazards or unsafe practices which could result in property damage.

NOTES highlight procedures and contain information which assist the operator in understanding the information contained in this manual.

All software, including design, appearance, algorithms and source codes, is copyrighted by Elsag Bailey Process Automation and is owned by Elsag Bailey Process Automation or its suppliers.

WARNING

POSSIBLE PROCESS UPSETS

Maintenance must be performed only by qualified personnel and only after securing equipment controlled by this product. Adjusting or removing this product while it is in the system may upset the process being controlled. Some process upsets may cause injury or damage.

NOTICE

The information contained in this document is subject to change without notice.

Elsag Bailey Process Automation, its affiliates, employees, and agents, and the authors of and contributors to this publication specifically disclaim all liabilities and warranties, express and implied (including warranties of merchantability and fitness for a particular purpose), for the accuracy, currency, completeness, and/or reliability of the information contained herein and/or for the fitness for any particular use and/or for the performance of any material and/or equipment selected in whole or part with the user of/or in reliance upon information contained herein. Selection of materials and/or equipment is at the sole risk of the user of this publication.

This document contains proprietary information of Elsag Bailey Process Automation, and is issued in strict confidence. Its use, or reproduction for use, for the reverse engineering, development or manufacture of hardware or software described herein is prohibited. No part of this document may be photocopied or reproduced without the prior written consent of Elsag Bailey Process Automation.



***ADDENDUM TO
SWIRLMETER INSTRUCTION BULLETIN
10SM1000, DESIGN LEVEL A***

<p>ADDENDUM TO SWIRLMETER INSTRUCTION BULLETIN 10SM1000, DESIGN LEVEL A (PN24821)</p>
--

The purpose of this addendum is to supply revised information applicable to the switch settings in Table 2-2 on Page 2-11 of Instruction Bulletin 10SM1000 (PN24821).

The attached TABLE 2-2 supersedes the information in the corresponding table in Instruction Bulletin 10SM1000.

Medium	Meter Size		SWITCHES TO BE IN CLOSED OR "ON" POSITION (ALL OTHER SWITCHES MUST BE OPEN)																			
	in.	mm	S1.1	S1.2	S1.3	S1.4	S1.5	S1.6	S1.7	S1.8	S2.1	S2.2	S2.3	S2.4	S3.1	S3.2	S3.3	S3.4	S3.5	S3.6	S3.7	S3.8
Gas	.5	15	●	●			●	●			●				●							
	.75	20	●	●			●	●			●				●							
	1	25	●	●			●	●			●				●							
	1.25	32	●		●		●		●		●					●						
	1.5	40	●		●		●		●		●					●						
	2	50	●	●	●	●	●	●	●	●	●					●						
	3	80	●		●		●		●			●						●				
	4	100	●	●	●	●	●	●	●	●		●						●				
	6	150			●				●				●					●				●
	8	200				●				●			●					●				●
	12	300		●	●	●			●	●	●		●								●	
16	400		●	●	●			●	●	●		●								●		
Liquid	.5	15				●				●				●				●				●
	.75	20				●				●	●	●			●	●	●	●	●	●	●	
	1	25				●				●				●					●			●
	1.25	32				●				●				●						●		●
	1.5	40				●				●				●						●		●
	2	50				●				●				●						●		●
	3	80			●	●				●	●			●					●	●		●
	4	100			●	●				●	●	●	●						●		●	●
	6	150			●	●				●	●	●	●	●	●	●	●	●	●	●	●	●
	8	200		●	●	●			●	●	●	●	●	●	●	●	●	●	●	●	●	●
	12	300		●	●	●			●	●	●	●	●	●	●	●	●	●	●	●	●	●
16	400		●	●	●			●	●	●	●	●	●	●	●	●	●	●	●	●	●	

NOTE: ● indicates switch to be in "closed" or "ON" position

TABLE 2-2. PREAMPLIFIER BOARD FILTER SWITCH SETTINGS

**CONVERSION INSTRUCTIONS
3-WIRE SENSOR TO 2-WIRE CONFIGURATION**

The purpose of this addendum is to provide information for converting three-wire Vortex and Swirlmeter sensors to two-wire configuration where applicable. Newer models of Vortex (Models 10VT) and Swirlmeters (Models 10ST) have terminal blocks that have been designed for use with 3-wire sensors. Models 10VM & 10VR and 10SM & 10SR continue to use 2-wire input terminal blocks and use the 3-wire sensor configured to a 2-wire mode as shown in the illustration below.

The 2-wire sensor configuration is also required when retrofitting older Vortex 10VT and Swirlmeter 10ST models with the new 3-wire sensors since the older models contain 2-wire terminal blocks on the circuit board.

3-WIRE SENSOR PART NUMBERS

B-F&P PART NUMBER	METER SIZE	GASKET TYPE	MATERIAL	LENGTH
D693B027U01 D693B027U09 D693B027U11 D693B027U03	1/2 - 6 inch (DN15 - DN150)	Flat O-Ring O-Ring Flat	Steel 1.4571 " " Hastelloy C	Standard
D693B029U01 D693B029U09 D693B029U11 D693B029U03	≥ 8 inch (≥ DN200)	Flat O-Ring O-Ring Flat	Steel 1.4571 " " Hastelloy C	Long

The sensors listed above have three wires:

- one **blue** lead
- one **red** lead
- one **yellow** lead

To convert the sensors to 2-wire mode:

- twist **yellow & red** wires together
- connect **yellow/red** wires to terminal 19 on the PCB terminal block
- connect **blue** wire to terminal 2B on the PCB terminal block

Refer to the generic cutaway diagram shown on the right for dressing and connection of the sensor leads. The diagram shows the newer "tower assembly" construction. Older "tower assemblies" will have different construction from that shown.

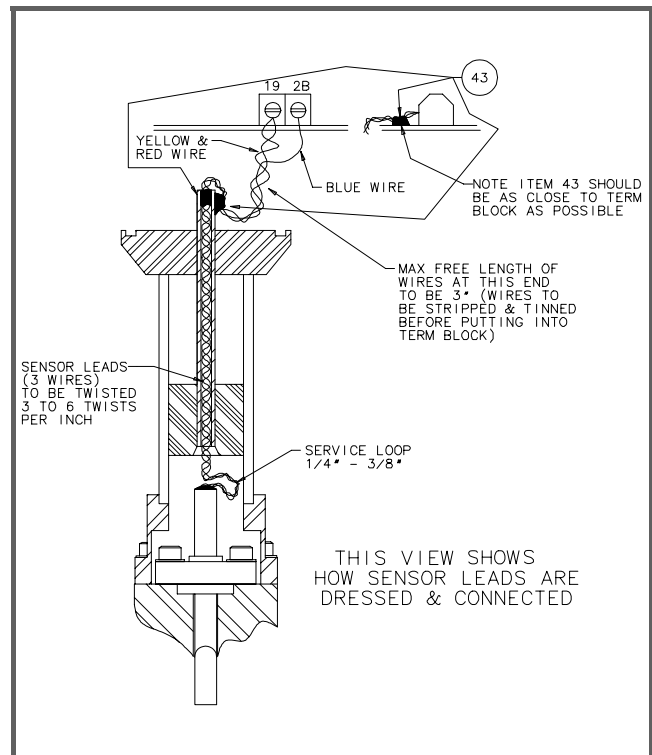

Table of Contents

SAFETY SUMMARY	I
READ FIRST	III
1.0 INTRODUCTION	1-1
1.1 Description	1-1
1.2 Principle of Operation	1-1
1.3 Back Pressure Requirements for Liquid Flow	1-2
1.4 Model Number Breakdown	1-3
1.5 Specifications	1-4
2.0 INSTALLATION	2-1
2.1 Inspection	2-1
2.2 Location and Mounting	2-1
2.2.1 Extreme Temperature Applications	2-1
2.3 Temperature/Pressure Monitoring	2-2
2.4 Meter Weights	2-2
2.5 Flanged Meter Installation	2-4
2.6 Electrical Interconnections	2-5
2.7 Preamplifier Board Switches	2-7
2.8 Conduit Seal and Pressure Relief	2-7
3.0 PARTS LIST	3-1

List of Figures

FIGURE 1-1. SWIRLMETER VORTEX GENERATION	1-1
FIGURE 1-2. SWIRLMETER OPERATING PRINCIPLE	1-2
FIGURE 1-3. PROCESS PRESSURE VS. TEMPERATURE	1-4
FIGURE 1-4. PROCESS OPERATING TEMPERATURES	1-5
FIGURE 1-5. METER PIPING REQUIREMENTS	1-6
FIGURE 2-1. PRESSURE AND TEMPERATURE MEASUREMENT LOCATIONS	2-2
FIGURE 2-2. SWIRLMETER OUTLINE DIMENSIONS	2-3
FIGURE 2-3. FLANGE BOLT TIGHTENING SEQUENCE	2-4
FIGURE 2-4. FLANGE PROCESS CONNECTIONS	2-4
FIGURE 2-5. PREAMPLIFIER BOARD LAYOUT (SENSOR CONNECTION SIDE)	2-5
FIGURE 2-6. PREAMPLIFIER BOARD LAYOUT (CABLE CONNECTION SIDE)	2-6
FIGURE 2-7. INTERCONNECTION WIRING DIAGRAM FOR NON-HAZARDOUS LOCATIONS	2-7
FIGURE 2-8. INTERCONNECTION WIRING DIAGRAM FOR INTRINSICALLY SAFE LOCATIONS	2-8
FIGURE 2-9. LOCATION OF PROGRAMMING SWITCHES	2-9
FIGURE 2-10. CONDUIT ENTRY SEAL INSTALLATION	2-10

List of Tables

TABLE 1-1. AIR FLOW RATES	1-7
TABLE 1-2. GAS PRESSURE LOSS CALCULATIONS	1-7
TABLE 1-3. WATER FLOW RATES	1-8
TABLE 1-4. LIQUID PRESSURE LOSS CALCULATIONS	1-8
TABLE 1-5. AIR FLOW RATES AT SELECTED PRESSURES	1-9
TABLE 1-6. SATURATED STEAM FLOW RATES	1-10
TABLE 2-1. SWIRLMETER WEIGHTS	2-2
TABLE 2-2. PREAMPLIFIER BOARD FILTER SWITCH SETTINGS	2-11
TABLE 3-1. FLANGE GASKETS	3-1

SAFETY SUMMARY

GENERAL WARNINGS

POSSIBLE PROCESS UPSETS

Maintenance must be performed only by qualified personnel and securing equipment controlled by this product. Adjusting product while it is in the system may upset the process being controlled. Some process upsets may cause injury or damage.

ELECTRICAL SHOCK HAZARD. Equipment powered by AC line voltage constitutes a potential electric shock hazard to the user. Make certain that the system power input leads are disconnected from the operating branch circuit before attempting electrical interconnections.

RETURN OF EQUIPMENT

All Flowmeters and/or Signal Converters being returned to Bailey-Fischer & Porter for repair must be free of any hazardous materials (acids, alkalis, solvents, etc.). A Material Safety Data Sheet (MSDS) for all process liquids must accompany returned equipment. Contact Bailey-Fischer & Porter for authorization prior to returning equipment.

INSTRUCTION MANUALS

Do not install, maintain or operate this equipment without reading, understanding and following the proper Bailey-Fischer & Porter instructions and manuals, otherwise injury or damage may result.

SPECIFIC WARNINGS

When the meter is used in a very high or low temperature process, the temperature of the meter body may be extremely hot or cold. If it is necessary to touch the sensor housing or meter body, insulated gloves must be worn to prevent serious injury. (pg. 2-1)

All Flowmeters and/or Signal Converters being returned to Bailey-Fischer & Porter for repair must be free of any hazardous materials (acids, alkalis, solvents, etc.). A Material Safety Data Sheet (MSDS) for all process liquids must accompany returned equipment. Contact Bailey-Fischer & Porter for authorization prior to returning equipment. (pg. III)

ELECTRICAL SHOCK HAZARD. Equipment powered by AC line voltage constitutes a potential electric shock hazard to the user. Make certain that the system power input leads are disconnected from the operating branch circuit before attempting electrical interconnections. (pg. 2-5)

**SPECIFIC
CAUTIONS**

The pipeline and meter body may be insulated by the user. However, the meter interconnection wiring box and the sensor housing tower must not be insulated. Ambient air is required to dissipate heat or cold build-up within the interconnection wiring box. (pg. 2-1)

Some of the IC devices used in the signal converter are static sensitive and may be damaged by improper handling. When adjusting or servicing the signal converter, use of a grounded wrist strap is recommended to prevent inadvertant damage to the integral solid state circuitry. (pg. 2-5)

All unused conduit entrances must have pipe plugs installed. This is required to maintain the NEMA 4X enclosure rating. (pg. 2-6)

READ FIRST

This Instruction Bulletin contains the following changes from the previous Rev.0 issue (PN24758):

- Changed sensor material from 321 SS to 316 SS (German sensor)
- Revision of some values in Tables 1-1, 1-3 & 1-6
- Revised switch settings for 12 & 16 inch GAS and 3, 4, 6, 12 & 16 inch LIQUID meters in Table 2-2.
- Added wiring diagrams, Figures 2-7 & 2-8.

WARNING

INSTRUCTION MANUALS

Do not install, maintain, or operate this equipment without reading, understanding and following the proper Bailey-Fischer & Porter instructions and manuals, otherwise injury or damage may result.

RETURN OF EQUIPMENT

All Flowmeters and/or Signal Converters being returned to Bailey-Fischer & Porter for repair must be free of any hazardous materials (acids, alkalis, solvents, etc). A Material Safety Data Sheet (MSDS) for all process liquids must accompany returned equipment. Contact Bailey-Fischer & Porter for authorization prior to returning equipment.

NEMA 4X, Corrosion Resistant Finish

This product is painted with a high performance epoxy paint. The corrosion protection provided by this finish is only effective if the finish is unbroken. It is the users' responsibility to "touch-up" any damage that has occurred to the finish during shipping or installation of the product. Special attention must be given to: meter flange bolting, pipe mounting of electronics, conduit entries and covers that are removed to facilitate installation or repair. For continued corrosion protection throughout the product life, it is the users' responsibility to maintain the product finish. Incidental scratches and other finish damage must be repaired and promptly re-painted with approved touch-up paint. Provide the model number and size of your product to the nearest Bailey-Fischer & Porter representative to obtain the correct touch-up paint.

Read these instructions before starting installation;
save these instructions for future reference.

1.0 INTRODUCTION

1.1 Description

The Bailey-Fischer & Porter 10SM1000 Swirlmeter is a flowmeter system comprised of the Swirlmeter Primary with an integral preamplifier box and a remotely mounted microprocessor-based 50VM1000 signal converter/flow computer. The flowmeter and signal converter are interconnected by a shielded signal cable. This arrangement allows the signal converter to be mounted a safe distance from any process fluid that may have an adverse effect on the signal converter electronics. The flowmeter, signal converter and signal cable are interconnected on-site. Information in this Instruction Bulletin is applicable only to the 10SM1000 Swirlmeter. For information applicable to the 50VM1000 signal converter, refer to the Instruction Bulletin supplied with the 50VM1000 converter.

The flowmeter is suitable for service with gas and liquid processes. The meter's extended temperature range permits accurate metering of saturated and superheated steam.

The flowmeter body and process connections are made from 316L stainless steel. The sensor is made from 316 stainless steel. Because the meter has no moving parts, routine maintenance is not required.

The 10SM1000 Swirlmeter is FM (Factory Mutual Research) approved as: Intrinsically Safe for Classes I, II and III, Division 1, Groups A, B, C, D, E, F and G, ENTITY; per ID-10-1105; Dust-ignitionproof for Class II Division 1, Groups E, F and G; Suitable for Class III Division 1; Nonincendive for Class I, Division 2, Groups A, B, C and D; for indoor/outdoor Hazardous (Classified) Locations; NEMA 4X.

1.2 Principle of Operation

The Swirlmeter body contains stationary swirler blades at the meter inlet. The design of these blades forces the axial flow of the fluid into a rotational movement. Due to this "swirling" of the fluid, a vortex is generated at the center of the rotation and forced by a backflow into a secondary rotation whose frequency is proportional to the flow rate. The generation of the vortex is shown pictorially in Figure 1-1. The generated frequency is linear over a wide flow range due to the optimized internal geometry of the instrument and is measured using a piezoelectric sensor. The sensor's frequency signal is converted by the Converter electronics into a 4 - 20mA DC output current.

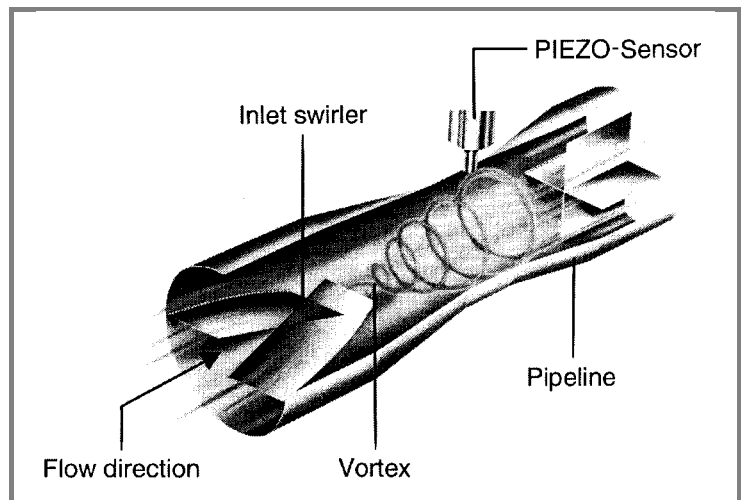

FIGURE 1-1. SWIRLMETER VORTEX GENERATION

Figure 1-2, below, shows diagrammatically the operating principle of the Swirlmeter with the vortex action formed by the generated backflow.

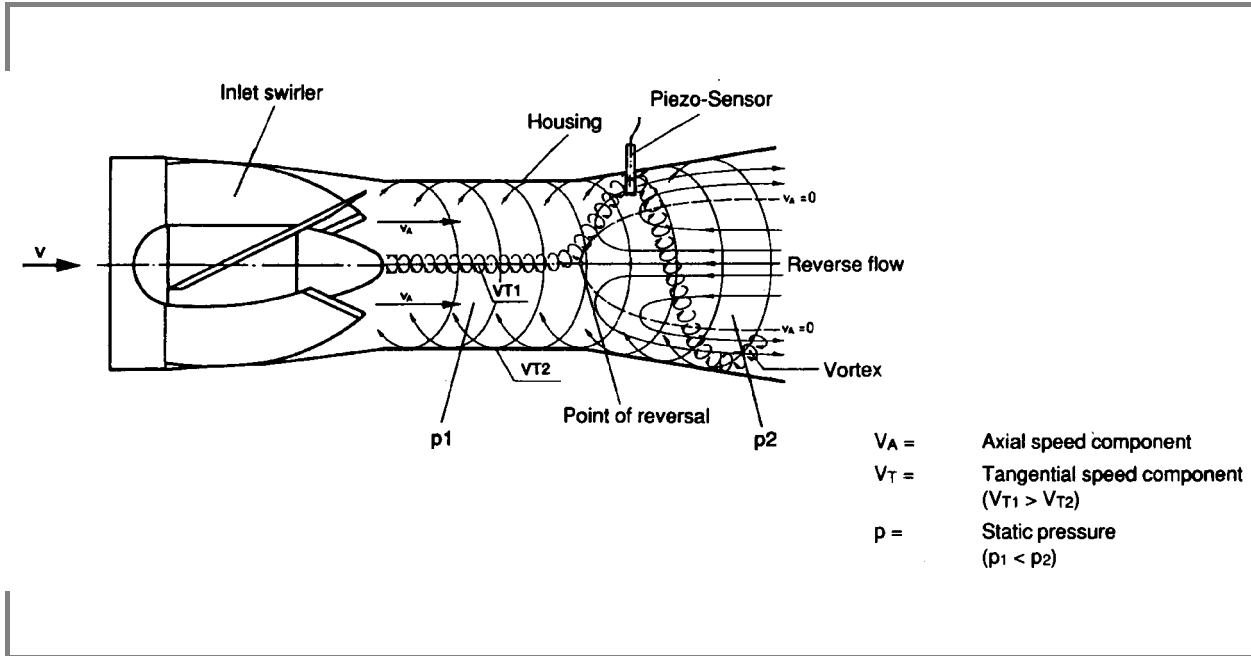

FIGURE 1-2 SWIRLMETER OPERATING PRINCIPLE

1.3 Back Pressure Requirements for Liquid Flow

To prevent cavitation in the meter it is necessary to maintain minimum back pressure in the system. The required back pressure is determined using the following formula:

$$P_b \geq 1.3P_v + 2.6\Delta P$$

where:

P_b = minimum back pressure (psig)

P_v = vapor pressure of the fluid at specified conditions (psig)

ΔP = pressure drop (psig)

1.4 Model Number Breakdown

Refer to the Bailey-Fischer & Porter data sheet or the data tag on the equipment for the model number of the instrument furnished. The details of a specific number are shown below:

	10SM	1	1	—	B	—	—	9	A	—	A	2
<u>Engineering Reference</u> Remote Swirlmeter												
<u>Design Designation</u> Fixed Data		1										
<u>Materials of Construction</u> Body/Sensor 316L/316 Stainless Steel			1									
<u>Fluid Type</u> Liquid Gas Natural Gas Saturated Steam Superheated Steam Oxygen Other				01 02 03 04 05 06 99								
<u>Design Level</u>					B							
<u>Meter Sizes</u> .75 in. (DN20) 1 in. (DN25) 1.25 in. (DN32) 2 in. (DN50) 3 in. (DN80) 4 in. (DN100) 6 in. (DN150) 8 in. (DN200) 12 in. (DN300) 16 in. (DN400)						B C D E F G H I K L						
<u>Pressure Rating</u> ANSI Class 150 (PN10) ANSI Class 300 (PN16)										P Q		
<u>Safety Approvals</u> Intrinsically Safe for Classes I, II & III, Div.1, Groups A thru G, ENTITY; per ID-10-1105; Dust-ignitionproof for Class II Div.1, Groups E, F& G; Suitable for Class III, Div.1; Nonincendive for Class I, Div.2, Groups A,B, C & D; for indoor/outdoor Hazardous (Classified) Locations; NEMA 4X.								9				
<u>Sensor</u> Fixed Data										A		
<u>Sensor Seal Material</u> Kalrez Viton Teflon (-20 to 230°C / -4 to 446°F) Other											3 4 5 9	
<u>Calibration</u> Fixed Data											A	
<u>Language</u> English												2

1.5 Specifications

Fluid Types

Gas, liquid or steam

Sizes (Available in Flanged Version Only)

inches	mm
.75	20
1	25
1.25	32
2	50
3	80
4	100
6	150
8	200
12	300
16	400

Accuracy

± 0.5% of rate

Rangeability

Typically 25 to 1. Refer to Tables 1-1 through 1-6.

Process Pressure Limits

Rated for ANSI Class 150 or 300 (DIN PN 10-16) service, 275/720 psig (1.91/4.96 MPa)

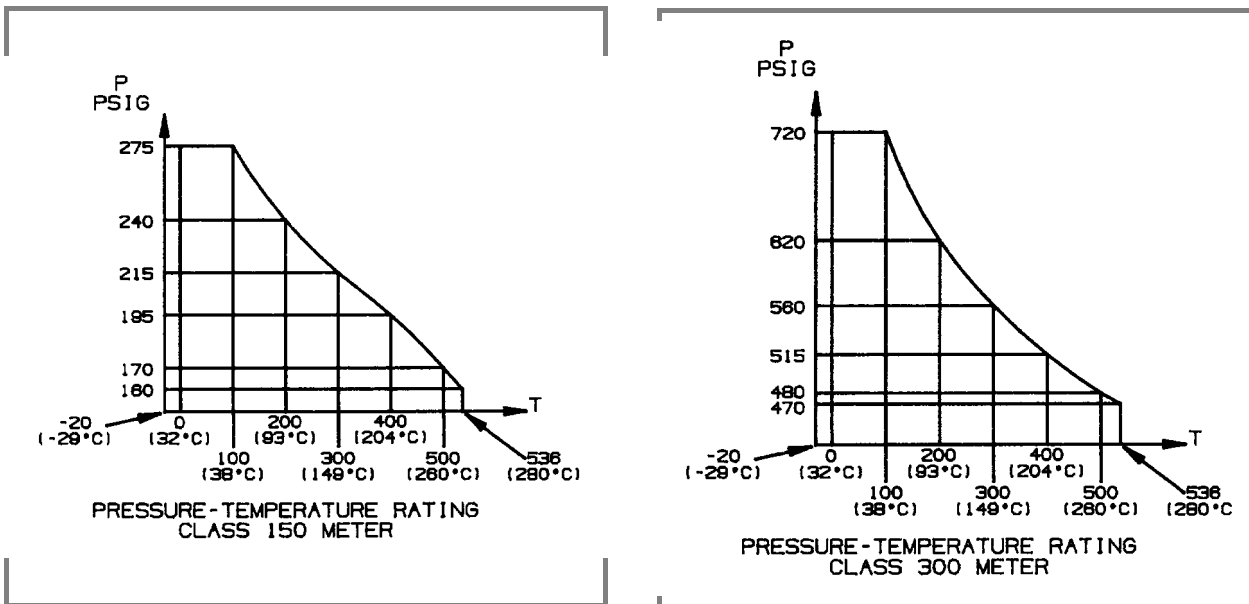

FIG. 1-3 PROCESS PRESSURE VS. TEMPERATURE

Process Temperature Limits

-40 to 536° F (-40 to 280° C)

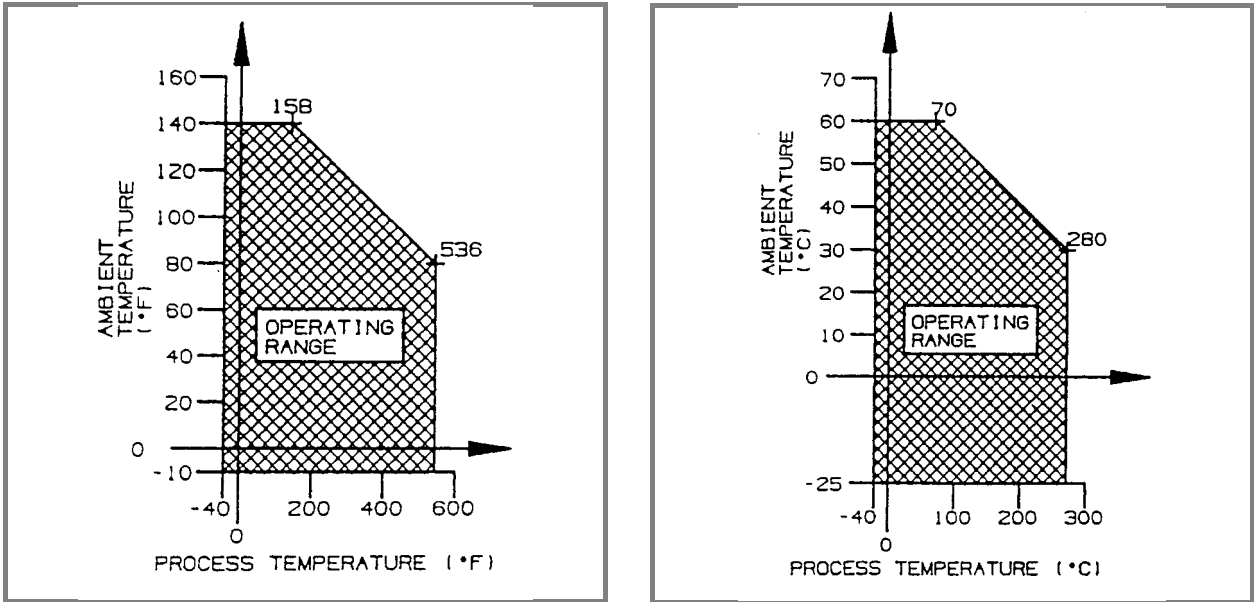

FIG. 1-4 PROCESS OPERATING TEMPERATURES

Ambient Temperature Limits

-10 to 140° F (-25 to 60° C)

Maximum Vibration Limits

Air: 0.15g at 0 - 130 Hz
Water: 0.3g at 0 - 130 Hz

Relative Humidity Limits

5 - 95% non-condensing

Materials of Construction:

Housing & Cover

304 SST

Body

316L SST

Sensor

316 SST

Sensor Seal Material

KALREZ

VITON

TEFLON (-20 TO 230°C / -4 to 446°F)

Certifications

Refer to Model Number Breakdown in Section 1.4.

Mounting

A minimum straight pipe run must be maintained up and downstream of the meter for various piping configurations. Refer to Figure 1-5 for minimum straight pipe run requirements. The Swirlmeter can be installed in any attitude.

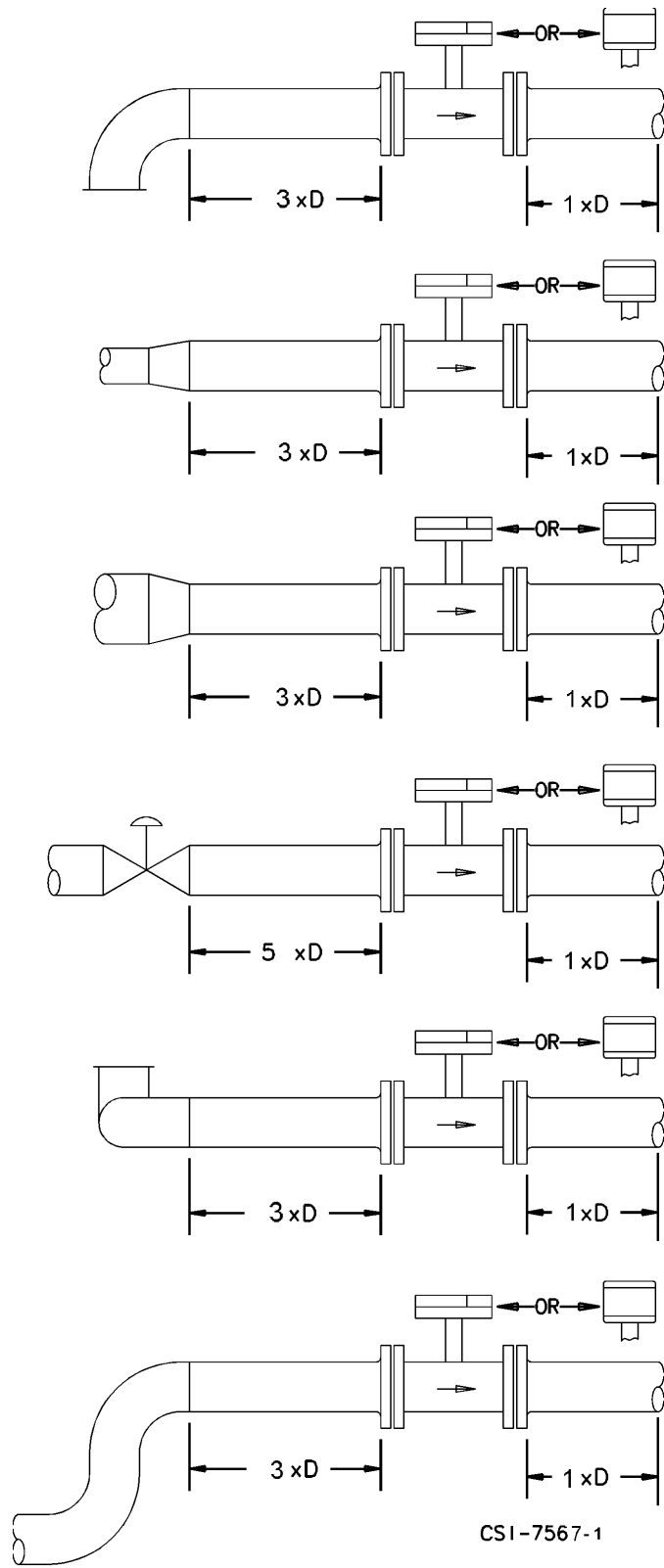

D = Meter Size

FIGURE 1-5. METER PIPING REQUIREMENTS

TABLE 1-1. AIR FLOW RATES

Meter Size		Minimum Air Flow	Maximum Air Flow			
inches	mm	acfh	acfh	min ft/sec	Frequency @ Max. flow (Hz)	max Δ p (psi)
.75	20	88	883	15	1200	0.4
1	25	177	1766	10	1200	0.5
1.25	32	248	4591	15	1200	1.05
2	50	636	12360	8.2	1200	1.3
3	80	1410	30018	7.2	680	1.03
4	100	2295	52973	7.5	670	1.35
6	150	4237	127132	6.2	470	1.4
8	200	7063	176575	5.6	280	1.25
12	300	14126	353150	4.9	160	1.3
16	400	35315	706300	7.2	150	1.3

TABLE 1-2. GAS PRESSURE LOSS CALCULATIONS

Pressure Loss For Steam and Gas
$\Delta p_2 = \Delta p_1 \frac{\rho}{.0749} \left(\frac{Q}{Q_{max}} \right)^2$
Δp ₂ = Pressure drop at operating conditions
Δp ₁ = Max. pressure drop for air from Table 1-1
ρ = Operating density (lbs/ft ³)
Q = Operating flow rate (acfh)
Q _{max} = Maximum air flow rate (acfh) from Table 1-1

Conversions: psi x 6.895 = kPa

General Conversions: .0749 = Density of air @ 14.7 psia & 70°F
 1 m³ = 264.2 gallons
 1 m³ = 35.31 ft³
 1 gallon H₂O = 8.345 lbs
 1 ft³ H₂O = 62.42 lbs

TABLE 1- 3. WATER FLOW RATES

Water Flow Rates at Standard Conditions @ 70°F (21°C)					
Meter Size		Flow Rate Limits (GPM)		Frequency @ Max. Flow	max Δp @ Max. Flow
inches	mm	Minimum	Maximum	Hz	psi
.75	20	1	9	100	3.6
1	25	2	27	135	4.3
1.25	32	4	44	107	3.6
2	50	11	110	90	3.6
3	80	15	440	78	7.2
4	100	22	660	77	6.5
6	150	66	1629	50	5.8
8	200	110	2200	30	7.2
12	300	440	4403	16	8
16	400	793	7925	13	8

NOTE: At Standard conditions at 70° F (21° C)

TABLE 1-4. LIQUID PRESSURE LOSS CALCULATIONS

Pressure Loss For Liquid Flow	
$\Delta p_2 = \Delta p_1 (\text{Sp. gr.}) \left(\frac{Q}{Q_{\max}} \right)^2$	
Δp ₂ = Pressure drop at operating conditions	
Δp ₁ = Max. pressure drop for water from Table 1-3	
Sp. gr. = Specific gravity at operating conditions	
Q = Operating flow rate (GPM)	
Q _{max} = Maximum meter water rate from Table 1-3	

Conversions: GPM x 0.22715 = m³/h
 psi x 6.895 = kPa

General Conversions: .0749 = Density of air @ 14.7 psia & 70°F
 1 m³ = 264.2 gallons
 1 m³ = 35.31 ft³
 1 gallon H₂O = 8.345 lbs
 1 ft³ H₂O = 62.42 lbs

TABLE 1-5. AIR FLOW RATES AT SELECTED PRESSURES

METER SIZE in. (mm)	AIR FLOW	AIR FLOW RATES IN SCFH						
		PRESSURE (psig)						
		0	25	50	100	150	200	300
.75 (20)	min.	88	127	161	215	258	294	356
	max.	883	2385	3886	6890	9893	12897	18903
1 (25)	min.	177	291	371	494	587	676	819
	max.	1766	4769	7773	13780	19786	25793	37807
1.25 (32)	min.	248	408	520	693	830	948	1147
	max.	4591	12399	20207	35822	51438	67054	98285
2 (50)	min.	636	1045	1334	1777	2111	2431	2943
	max.	12360	33380	54401	96442	138482	180523	264605
3 (80)	min.	1410	2319	2957	3937	4718	5387	6522
	max.	30018	81069	132120	234222	336324	438426	642630
4 (100)	min.	2295	3771	4815	6411	7617	8771	10618
	max.	52973	143063	233153	413334	593514	773694	1134055
6 (150)	min.	4237	6969	8886	11832	14178	16188	19599
	max.	127132	343343	559554	991976	1424397	1856819	2721663
8 (200)	min.	7063	11607	14817	19729	23441	26993	32679
	max.	176575	476873	777170	1377765	1978361	2578956	3780146
12 (300)	min.	14126	23214	29635	39458	46882	53985	65358
	max.	353150	953745	1554340	2755531	3956721	5157912	7560293
16 (400)	min.	35315	58035	74087	98644	117205	134963	163395
	max.	706300	1907490	3108681	5511062	7913443	10315824	15120586

For gases with densities other than air:

$$SCFH = ACFH \cdot \left(\frac{P}{14.7}\right) \cdot \left(\frac{530}{460 + ^\circ F}\right)$$

$$Q_{min} = ACFH_{min} (.0749/\rho)^{1/2}$$

$$Q_{max} = ACFH_{max} \cdot \left(\frac{P}{14.7}\right) \cdot \left(\frac{530}{460 + ^\circ F}\right)$$

where P = Operating pressure (psia)
 $ACFH_{min}$ = Refer to Table 1-1
 $ACFH_{max}$ = Refer to Table 1-1
 ρ = Density of fluid at operating conditions (lbs/ft³)
.0749 = Density of air @ 14.7 psia & 70°F

Meter Size →	FLOW RATES IN POUNDS PER HOUR (PPH)																			
	.75 in.		1 in.		1.25 in.		2 in.		3 in.		4 in.		6 in.		8 in.		12 in.		16 in.	
	min.	max.	min.	max.	min.	max.	min.	max.	min.	max.	min.	max.	min.	max.	min.	max.	min.	max.	min.	max.
15	7	64	13	129	18	335	47	902	104	2191	170	3876	313	9281	522	12890	1045	25780	2611	51560
30	8	94	16	187	22	487	57	1310	126	3182	204	5615	378	13476	629	18717	1259	37434	3147	74868
60	10	152	20	304	28	790	72	2126	160	5163	260	9111	481	21867	802	30371	1603	60742	4007	121484
100	12	227	25	454	34	1180	88	3177	196	7715	318	13614	588	32763	980	45380	1960	90760	4900	181519
125	13	275	27	551	38	1432	97	3856	216	9366	351	16528	648	39665	1080	55091	2159	110183	5399	220366
150	14	320	29	639	41	1662	105	4474	232	10876	378	19176	698	46022	1163	63920	2326	127840	5815	255681
200	16	411	33	823	46	2139	119	5760	263	13988	429	24685	792	59244	1320	82284	2639	164568	6598	329136
225	17	460	35	920	49	2392	126	6440	279	15639	453	27599	837	66236	1395	91996	2790	183991	6976	367982
250	18	507	37	1014	51	2635	132	7095	292	17230	476	30407	879	72974	1464	101354	2929	202708	7322	405416
300	20	600	40	1201	56	3122	144	8405	318	20412	518	36022	956	86450	1594	120071	3188	240142	7970	480284
400	23	788	46	1575	64	4095	164	11025	364	26776	593	47252	1095	113402	1825	157505	3650	315010	9125	630020

For other steam densities:

$$Q_{\min} \text{ (PPH)} = \text{ACFH}_{\min} (.0749/\rho)^{1/2} \cdot \rho$$

$$Q_{\max} \text{ (PPH)} = \text{ACFH}_{\max} \cdot \rho$$

where: ACFH_{\min} & ACFH_{\max} refer to values from Table 1-1
 ρ = fluid Density at operating conditions in lbs/ft³
.0749 = Density of air @ 14.7 psia & 70° F

TABLE 1-6. SATURATED STEAM FLOW RATES

2.0 INSTALLATION

2.1 Inspection

All equipment should be inspected for damage that may have occurred during shipment. All damage should be reported to the shipping agent. If the equipment is damaged to the extent that faulty operation may result, contact Bailey-Fischer & Porter before installation. Always reference the complete instrument serial number and model number in all correspondence concerning the equipment supplied.

2.2 Location and Mounting

The meter can be installed in any attitude. The meter is available in a flange style body that mounts between adjacent pipe flanges of the process piping. Since the meter is unidirectional, it must be oriented in accordance with the direction of the process flow. A flow direction arrow is provided on the meter body to assure correct orientation.

Strainers and flow straighteners are not required. Refer to Figure 1-5 for meter piping requirements.

Assuming a properly supported pipeline, vibration problems should not be encountered in normal industrial applications.

In vertical and sloping installations, the electrical conduit entries should face downward to preclude the entry of condensation. In horizontal installations, when process temperatures above 160° F (71° C) or below 0° F (-18° C) are encountered, **the meter must be oriented so that the junction box is located to the side of the meter body, not above or below.**

CAUTION

The pipeline and meter body may be insulated by the user. However, the meter interconnection wiring box and sensor housing tower must not be insulated. Ambient air is required to dissipate heat or cold build-up within the interconnection wiring box.

The meter includes a pressure relief feature described in Section 2.8. Take the location of this pressure relief into consideration when locating and orienting your meter.

2.2.1 Extreme Temperature Applications

For process temperatures above 160° F (71° C) or below 0° F (-18° C), it is critical that the meter be pressurized and placed into service gradually, i.e., with sufficient time delay to minimize thermal shock. Steam should be introduced gradually so that the meter is brought up to operating temperature over a ten to fifteen minute interval.

WARNING

When the meter is used in a very high or low temperature process, the temperature of the meter body may be extremely hot or cold. If it is necessary to touch the sensor housing or meter body, insulated gloves must be worn to prevent serious injury.

2.3 Temperature/Pressure Monitoring

Provisions for temperature and/or pressure monitoring are the responsibility of the user. The temperature sensor should be located approximately three pipe diameters downstream of the flowmeter. Measurement is from the downstream face of the meter. The pressure tap is located in the Swirlmeter body as shown in Fig. 2-1. Measurement is from the downstream face of the meter.

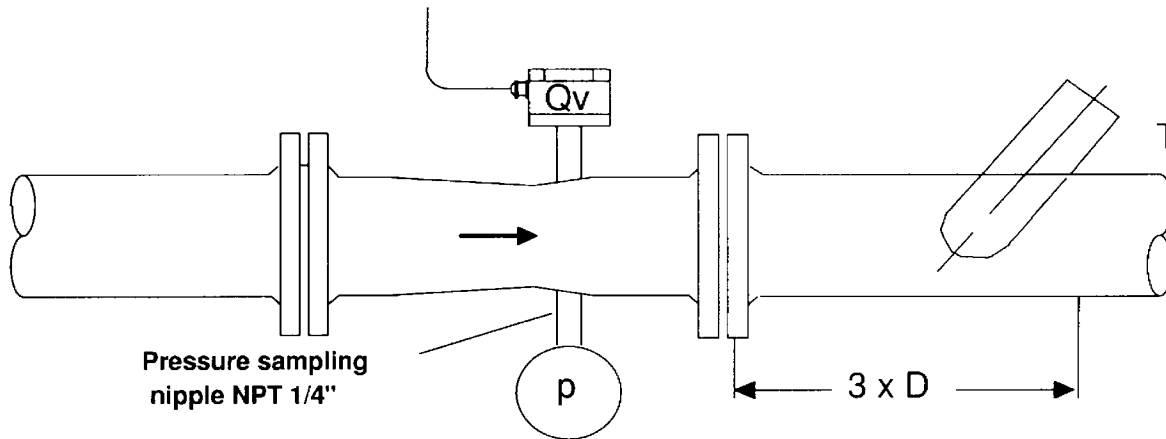

FIGURE 2-1. PRESSURE AND TEMPERATURE MEASUREMENT LOCATIONS

2.4 Meter Weights

The weights shown in the following table are approximate and should only be used as a guide when installing the meter.

TABLE 2-1. SWIRLMETER WEIGHTS

Meter Size		Flange Class 150 lbs (kg)	Flange Class 300 lbs (kg)
inch	mm		
.75	20	4.7 (2.1)	6.6 (3.0)
1	25	7.9 (3.6)	9.7 (4.4)
1.25	32	8.2 (3.7)	11.9 (5.4)
2	50	15.7 (7.1)	21.6 (9.8)
3	80	25.8 (11.7)	35.7 (16.2)
4	100	40.8 (18.5)	60.6 (27.5)
6	150	66.3 (30.1)	101.5 (46.0)
8	200	99.5 (45.1)	165.5 (75.1)
12	300	401 (182)	-
16	400	574 (260)	-

Refer to Figure 2-2 for outline dimensions of the flowmeter.

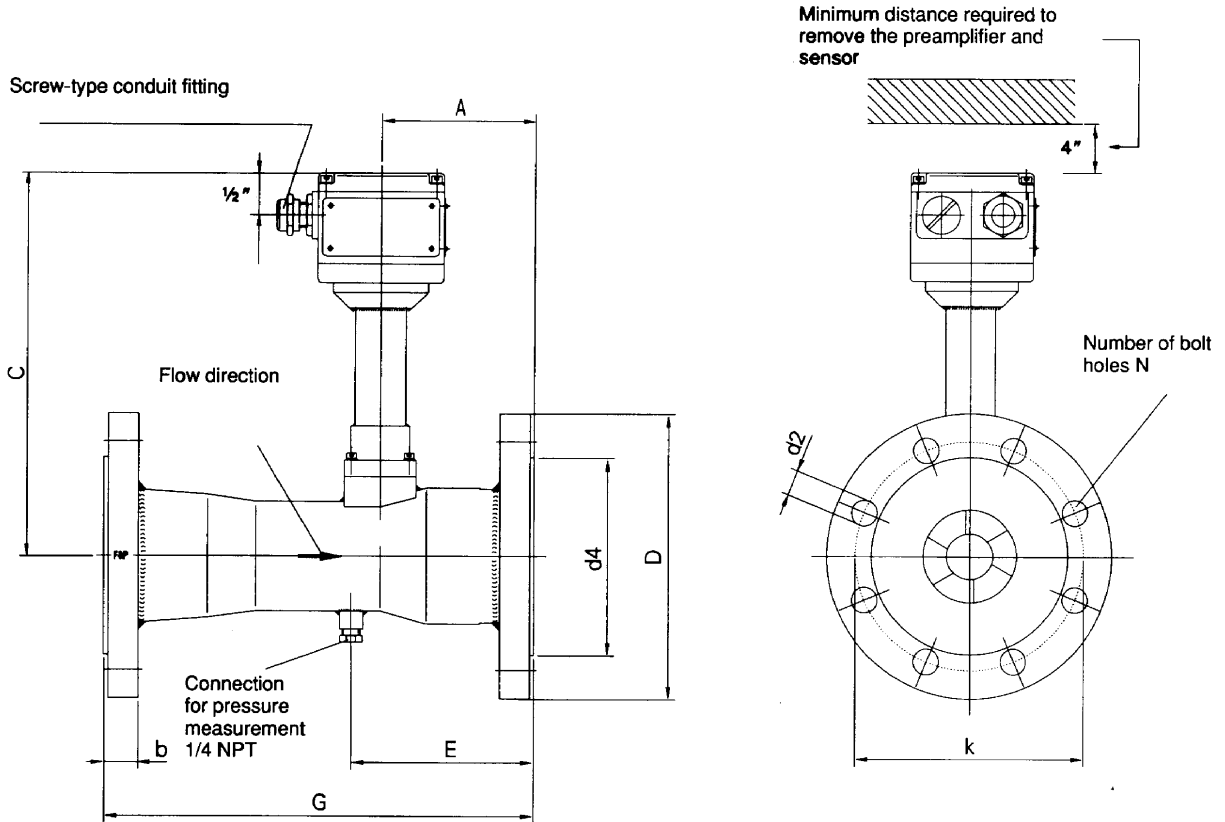

OUTLINE DIMENSIONS Inches (mm)

SIZE	ANSI RATING	A	C	E	G	D	b	K	d ₂	d ₄	N
3/4 (20)	150	2	8-3/4	2-3/8	4-3/4	3-7/8 (98.6)	1/2 (12.7)	2-3/4 (69.9)	5/8 (15.7)	1-11/16 (42.9)	4
	300	(52)	(221)	(60)	(120)	4-5/8 (117)	5/8 (15.7)	3-1/4 (82.5)	3/4 (19)	1-11/16 (42.5)	
1 (25)	150	2-3/16	8-3/4	2-1/2	6"	4-1/4 (107.9)	1/2 (14.3)	3-1/8 (79.4)	5/8 (15.9)	2 (50.8)	4
	300	(55)	(221)	(62.5)	(150)	4-7/8 (123.8)	5/8 (17.5)	3-1/2 (88.9)	3/4 (19)	2 (50.8)	
1-1/4 (32)	150	2-3/16	8-7/8	2-1/2	6	4-5/8 (117.5)	5/8 (15.3)	3-1/2 (88.9)	5/8 (15.9)	2-1/2 (63.4)	4
	300	(55)	(225)	(65)	(150)	5-1/4 (133.3)	3/4 (19)	3-7/8 (96.4)	3/4 (19)	2-1/2 (63.4)	
2 (50)	150	2-3/4	9	3-11/32	8	6 (152)	3/4 (19)	4-3/4 (121)	3/4 (19)	3-5/8 (92.1)	4
	300	(71)	(230)	(65)	(200)	6-1/2 (165.1)	7/8 (22.2)	5 (127)	3/4 (19)	3-5/8 (92.1)	8
3 (80)	150	4-1/8	9-3/8	5	12	7-1/2 (190.5)	1 (25.4)	6 (152.4)	3/4 (19)	5 (127)	4
	300	(105)	(236)	(125)	(300)	8-1/4 (209.5)	1-1/8 (28.6)	6-5/8 (168.3)	7/8 (22.2)	5 (127)	8
4 (100)	150	4-7/8	9-19/32	5-7/8	13-3/4	9 (228.6)	15/32 (23.8)	7-1/2 (190.5)	3/4 (19)	6-3/16 (157.2)	8
	300	(124)	(244)	(149)	(350)	6-11/16 (254)	1-1/4 (31.7)	8 (200)	7/8 (22.2)	6-3/16 (157.2)	
6 (150)	150	6	10-3/8	7-1/2	18-7/8	11 (279.4)	1 (25.4)	9-1/2 (241.3)	7/8 (22.2)	8-1/2 (215.9)	8
	300	(150)	(264)	(188)	(480)	12-1/2 (317.5)	1-1/2 (38.5)	10-5/8 (269.9)	7/8 (22.2)	8-1/2 (215.9)	12
8 (200)	150	6-5/8	11-1/8	8-1/2	23-5/8	13-1/2 (343)	1-1/8 (28.6)	11-3/4 (298.4)	7/8 (22.2)	10-5/8 (270)	8
	300	(170)	(284)	(215)	(600)	15 (381)	1-5/8 (41.3)	13 (330.2)	1 (25.4)	10-5/8 (270)	12
12 (300)	150	13-1/4	13-1/2	16-5/8	39-3/8	19 (482.6)	1-1/4 (31.7)	17 (431.8)	1 (25.4)	15 (381)	12
	300	(336)	(341)	(423)	(1000)	-	-	-	-	-	
16 (400)	150	17	14-3/4	21-1/2	50	23-1/2 (597)	1-1/2 (36.5)	21-1/4 (539.7)	1-1/8 (28.6)	18-1/2 (470)	16
	300	(434)	(374)	(544)	(1270)	-	-	-	-	-	

FIGURE 2-2. SWIRLMETER OUTLINE DIMENSIONS

2.5 Flanged Meter Installation

To assure optimum meter performance, the meter should be installed in accordance with the upstream and downstream straight run piping requirements shown in Figure 1-5. The straight run piping should be schedule 80 or lighter pipe. Process flanges should be raised face.

Remove the covers used to protect the meter inlet and outlet surfaces from damage during shipment.

Place the two supplied flange gaskets against the upstream and downstream flange faces. Align the gasket holes with the flange hole pattern. When installing the flange gaskets, make sure that the gaskets fit properly and are aligned properly so that they don't project into the pipe line causing an alteration of the flow profile. A change in flow profile can adversely affect meter accuracy.

Mounting bolts and nuts are supplied by the user. During installation, make certain that the **flow direction arrow** on the meter body is oriented in accordance with the process flow.

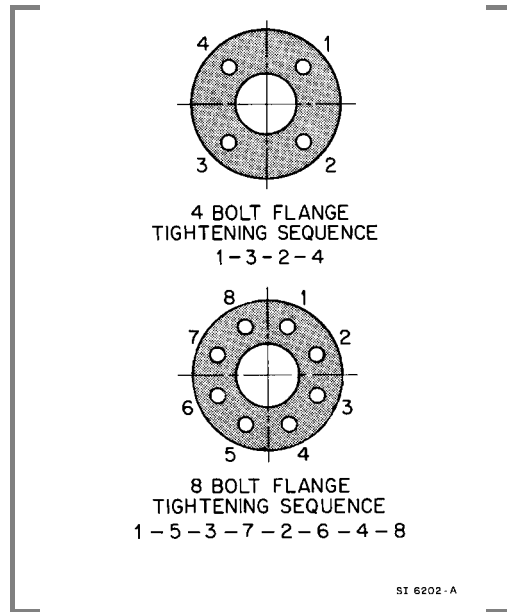

FIGURE 2-3. FLANGE BOLT TIGHTENING SEQUENCE

With the meter safely supported, install the bolts through the meter and process flanges. Bolts and nuts should be lubricated with a graphite based lubricant. Assemble the nuts to the bolts hand tight. Tighten the flange nuts in a diagonal or "star" pattern as shown in Figure 2-3.

This "star" pattern tightening sequence is recommended to equalize pressure on both the flange face and gaskets. Bolt/nut torque should be limited to that which will provide a leakproof seal.

When correctly installed, the installation should look like that shown in Figure 2-4 below.

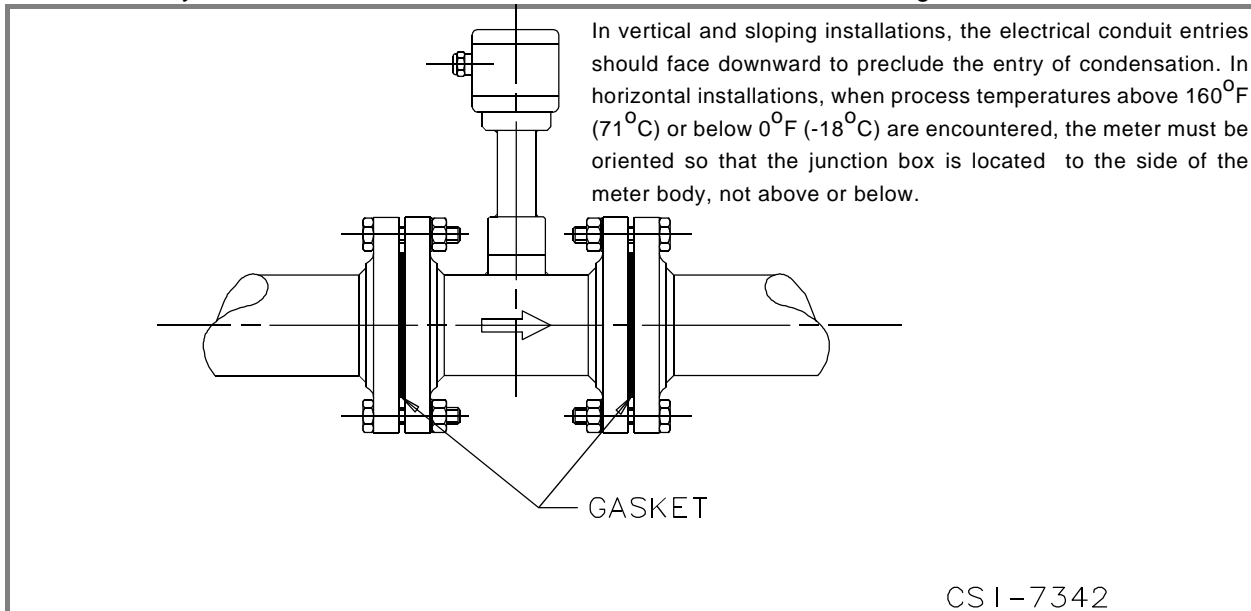

FIGURE 2-4. FLANGE PROCESS CONNECTIONS

2.6 Electrical Interconnections

The 10SM1000 Swirlmeter is provided with a 50VM1000 remotely-mounted signal converter. Interconnection details are provided in the Instruction Bulletin provided with the 50VM1000. If the 50VM1000 is powered by AC line voltage, proper care must be exercised when making electrical interconnections.

WARNING

ELECTRICAL SHOCK HAZARD. Equipment powered by AC line voltage constitutes a potential electric shock hazard to the user. Make certain that the system power input leads are disconnected from the operating branch circuit before attempting electrical interconnections.

The 10SM1000 electronics housing contains a preamplifier circuit board assembly which contains the terminal blocks to attach the sensor leads and interconnect cable. The circuit board assembly is a single circuit board with components mounted on both sides of the assembly. The underside of the circuit board (as-mounted) contains terminal block x1 for the connection of the sensor leads. This layout is shown in Figure 2-5 below.

CAUTION

Some of the IC devices used in the signal converter are static sensitive and may be damaged by improper handling. When adjusting or servicing the signal converter, use of a grounded wrist strap is recommended to prevent inadvertant damage to the integral solid state circuitry.

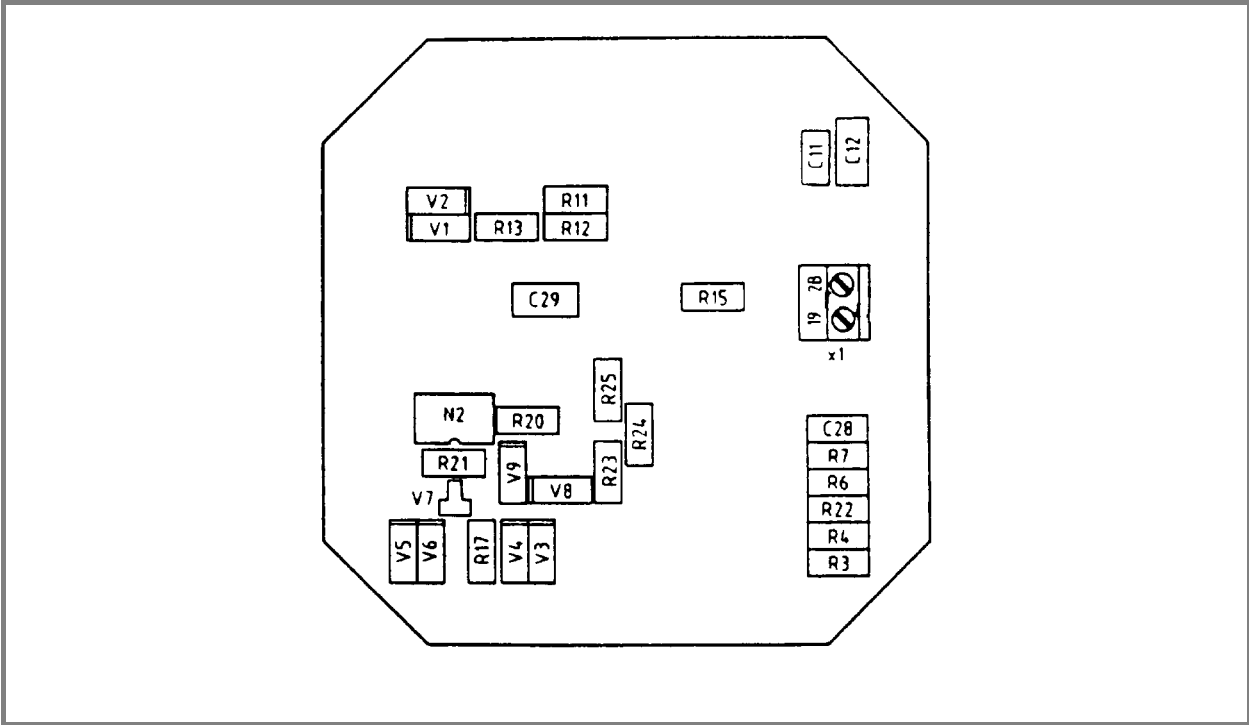

**FIGURE 2-5. PREAMPLIFIER BOARD LAYOUT
(SENSOR CONNECTION SIDE)**

The top side of the preamplifier circuit board contains the bulk of the preamplifier circuitry, terminal block x2 for connection of the interconnect cable leads and the preamplifier circuit programming switches S1.1-S1.8, S2.1-S2.4 and S3.1-S3.8. These switches are discussed further in Section 2.7. The layout of the top side of the preamplifier board assembly is shown in Figure 2-6 below.

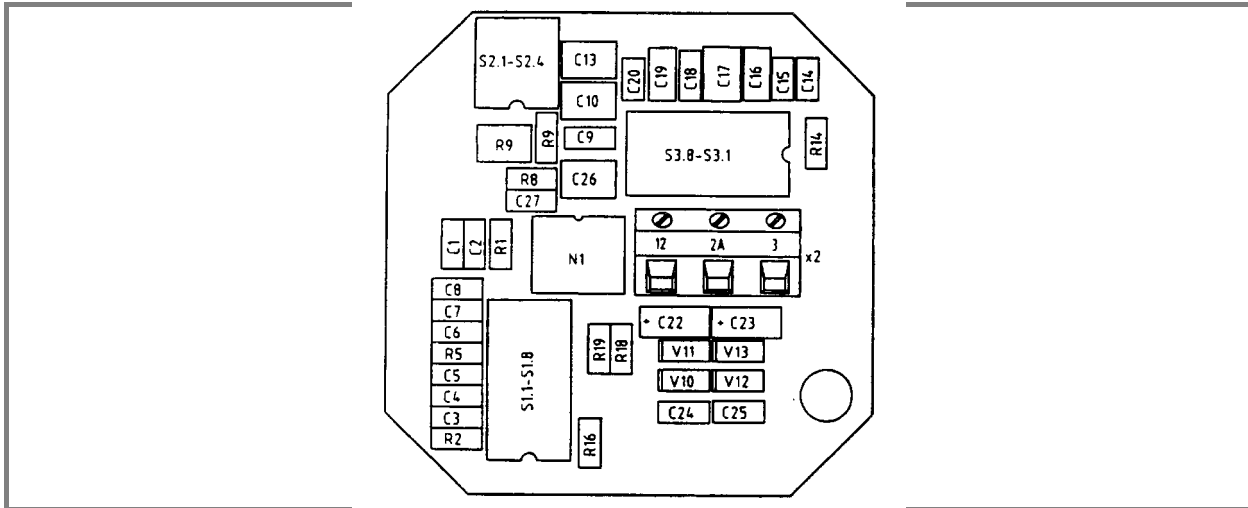

**FIGURE 2-6. PREAMPLIFIER BOARD LAYOUT
(CABLE CONNECTION SIDE)**

The interconnect cable attaches to terminal block x2 (terminals 12, 2A & 3). The wires in the interconnect cable are color-coded. When making the cable connections between the Primary and the converter, make certain that the wire color associated with a terminal number at the Primary is connected to the corresponding terminal at the converter since the order of the terminal numbering is different at the converter end.

Note that the interconnect cable shield is only connected at the 10SM1000 Primary terminal block and does not get connected at the 50VM1000 converter. Maximum length of the interconnect cable is 2600 feet (800 meters). Refer to Figures 2-7 & 2-8 for the interconnection wiring diagrams.

The flowmeter preamplifier housing cover is removable and may be removed for access during installation and maintenance. Remove the cover from the housing by loosening the screws on the cover. Figure 2-2 in this chapter specifies the clearance required above the preamplifier connection box to provide access to the cover retaining screws.

Replace the covers when the installation has been completed and **before** power is applied to the equipment. Make certain that covers are replaced properly after maintenance by using the following procedures:

- Check that gaskets are properly seated and are not pinched or stretched.
- Check that gasket surfaces are clean and free of grease or other contaminants.
- Align covers on housing and re-install bolts.
- Tighten bolts finger tight.
- Finish tightening bolts in a "star" pattern to distribute force evenly.

CAUTION
All unused conduit entrances must have pipe plugs installed. This is required to maintain the NEMA 4X enclosure rating.

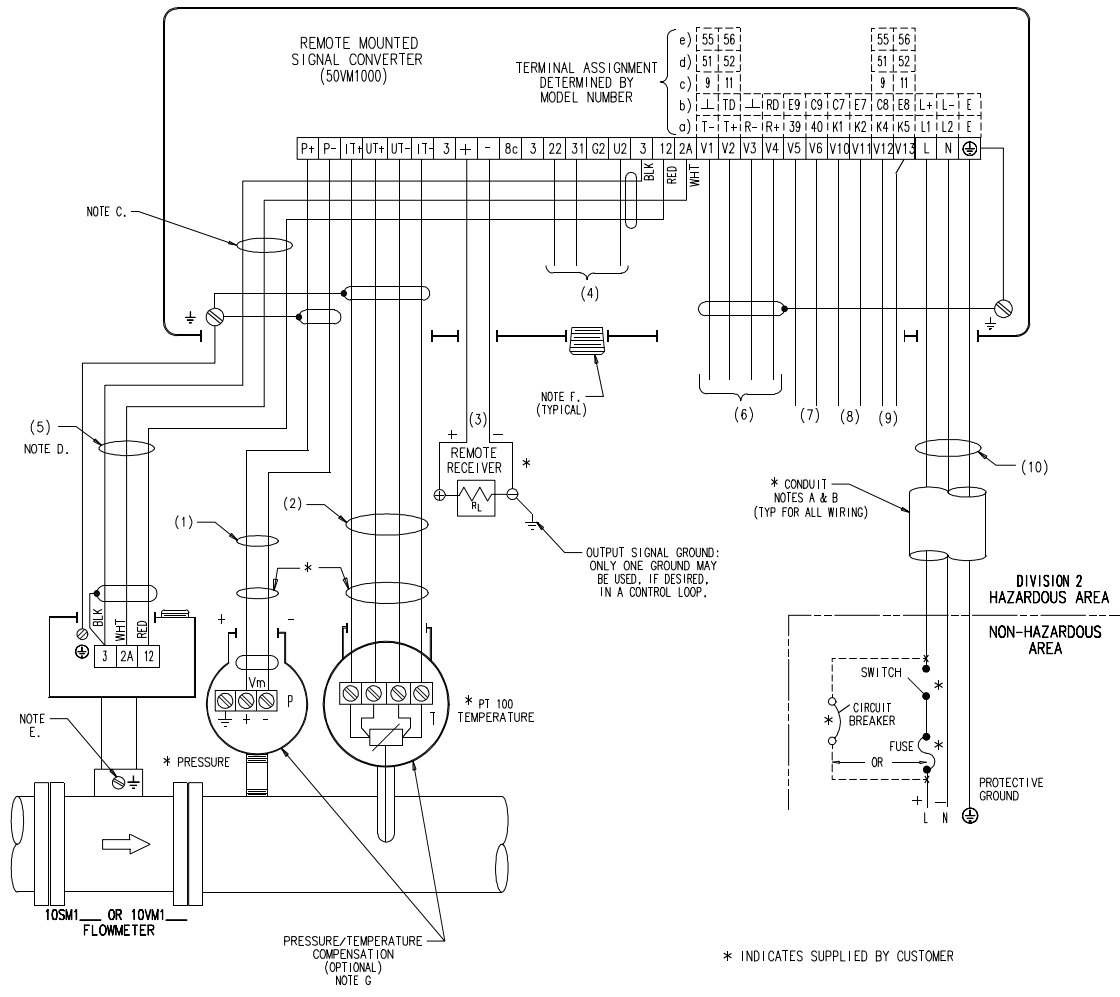

- INSTALLATION NOTES**
- A. EQUIPMENT AND WIRING TO BE INSTALLED IN ACCORDANCE WITH ANSI/NFPA 70 (NATIONAL ELECTRICAL CODE) AND LOCAL CODE REQUIREMENTS.
 - B. HAZARDOUS LOCATIONS: WIRING TO BE IN CONDUIT, BOXES, FITTINGS AND SEALS TO COMPLY WITH ARTICLE 501 OF ANSI/NFPA 70 AND LOCAL ELECTRICAL CODE REQUIREMENTS.
 - C. SHIELDED CABLE IS REQUIRED. THE UNTERMINATED END OF THE SHIELD SHALL BE INSULATED FROM THE CONVERTER.
 - D. USE NEC TYPE CMR, 22 AWG MINIMUM (BELDEN 9363 OR EQUIVALENT). FOR PROCESS TEMPERATURES GREATER THAN 105°C AND PLENUM SERVICE, USE NEC TYPE CMP (BELDEN 83553 OR EQUIVALENT).
 - E. BODY OF FLOWMETER SHALL BE GROUNDED THROUGH THE PIPELINE FLANGES OR THROUGH THE METER EXTERNAL GROUND TERMINAL.
 - F. SEALS REQUIRED AT UNUSED CONDUIT ENTRIES TO MAINTAIN NEMA 4X ENCLOSURE RATINGS.
 - G. APPROVAL DOES NOT INCLUDE OPTIONAL PRESSURE TRANSDUCER AND PT100 TEMPERATURE SENSOR. THESE COMPONENTS ARE SUPPLIED BY THE END USER AND MUST BE APPROVED BY FMRC FOR THE SPECIFIC HAZARDOUS LOCATION.
- TERMINAL ASSIGNMENT TABLE**
- (1) PRESSURE INPUT (CURRENT): MAXIMUM LENGTH 2600ft (800m)
PRESSURE SENSOR 0/4-20mA; P+ = 30 V.
 - (2) TEMPERATURE INPUT: MAXIMUM LENGTH 2600ft (800m)
PT100 - RESISTANCE, IP = 1mA; VP = 19.5 - 247mV FOR -328 TO +752°F (-200 TO +400 °C)
 - (3) CURRENT OUTPUT: MAXIMUM LENGTH 4900ft (1500m)
SELECTABLE; LOAD <750 OHMS, 0-20mA, 4-20mA, 0-10mA, 2-10mA
 - (4) 22/U2: EXTERNAL ZERO RETURN, PASSIVE CONTACT CLOSURE
31/U2: EXTERNAL TOTALIZER RESET, PASSIVE CONTACT CLOSURE, BOTH INPUTS OPTOCOUPLER ISOLATED
 - (5) SIGNAL CABLE: (CONNECT SHIELD ONLY AT PREAMPLIFIER) MAXIMUM LENGTH 2600ft (800m)
 - (6) DATA LINK OR PULSE OUTPUT:
 - a) DATA LINK RS 485; MAXIMUM LENGTH 3940ft (1200m)
 - b) DATA LINK RS 232C/24V; MAXIMUM LENGTH 501ft (15m)
 - c) SCALED PULSE OUTPUT, ACTIVE, 24Vdc, LOAD >150 OHMS
 - d) SCALED PULSE OUTPUT, PASSIVE, RELAY CONTACT CLOSURE, <120mA, <30Vdc
 - e) SCALED PULSE OUTPUT, OPTOCOUPLER, 5V <Vce <25V, 5mA <Ice <30mA
- NOTE:** A SHIELDED DATA CABLE IS RECOMMENDED FOR USE WITH THE RS 232C DATA LINK; A SHIELDED CABLE WITH INDIVIDUALLY TWISTED PAIRS IS RECOMMENDED FOR USE WITH THE RS 485 DATA LINK.
- (7) ALARM CONTACT, OPENS IN ALARM CONDITION
 - a) ALARM CONTACT, RELAY, <120mA, <30Vdc
 - b) ALARM OUTPUT, OPTOCOUPLER, Vce <25V, Ice <7.5mA
 - (8) MAX-ALARM
 - a) ALARM CONTACT, RELAY, OPENS, <120mA, <30Vdc
 - b) ALARM OUTPUT, OPTOCOUPLER, Vce <25V, Ice <7.5mA
 - (9) PULSE OUTPUT OR MIN-ALARM
 - a) ALARM CONTACT, RELAY, OPENS, <120mA, <30Vdc
 - b) ALARM OUTPUT, OPTOCOUPLER, Vce <25V, Ice <7.5mA
 - c) SCALED PULSE OUTPUT, ACTIVE, 24Vdc, LOAD >150 OHMS
 - d) SCALED PULSE OUTPUT, PASSIVE, RELAY CONTACT CLOSURE, <120mA, <30Vdc
 - e) SCALED PULSE OUTPUT, OPTOCOUPLER, 5V <Vce <25V, 5mA <Ice <30mA
 - (10) POWER SUPPLY (SEE DATA TAG): a) AC 50/60Hz b) LOW VOLTAGE AC 50/60Hz c) DC
Vmax = 30 V Ci = 0 uF
Imax = 120 mA Li = 0 mH
 - (12) THE POWER SOURCE CONNECTED TO TERMINALS V1 & V2, V3 & V4, V5 & V6, V10 & V11, V12 & V13 MUST BE FMRC APPROVED WITH NON-INCENDIVE FIELD CIRCUITS SPECIFYING Vcc, Isc, Co AND Lc. ALL OTHER I/O ARE TERMINALS TO BE IN ACCORDANCE WITH ANSI/NFPA 70 (NATIONAL ELECTRICAL CODE).

(10-50-1829-5 REF)

FIGURE 2-7. INTERCONNECTION WIRING DIAGRAM FOR NON-HAZARDOUS LOCATIONS

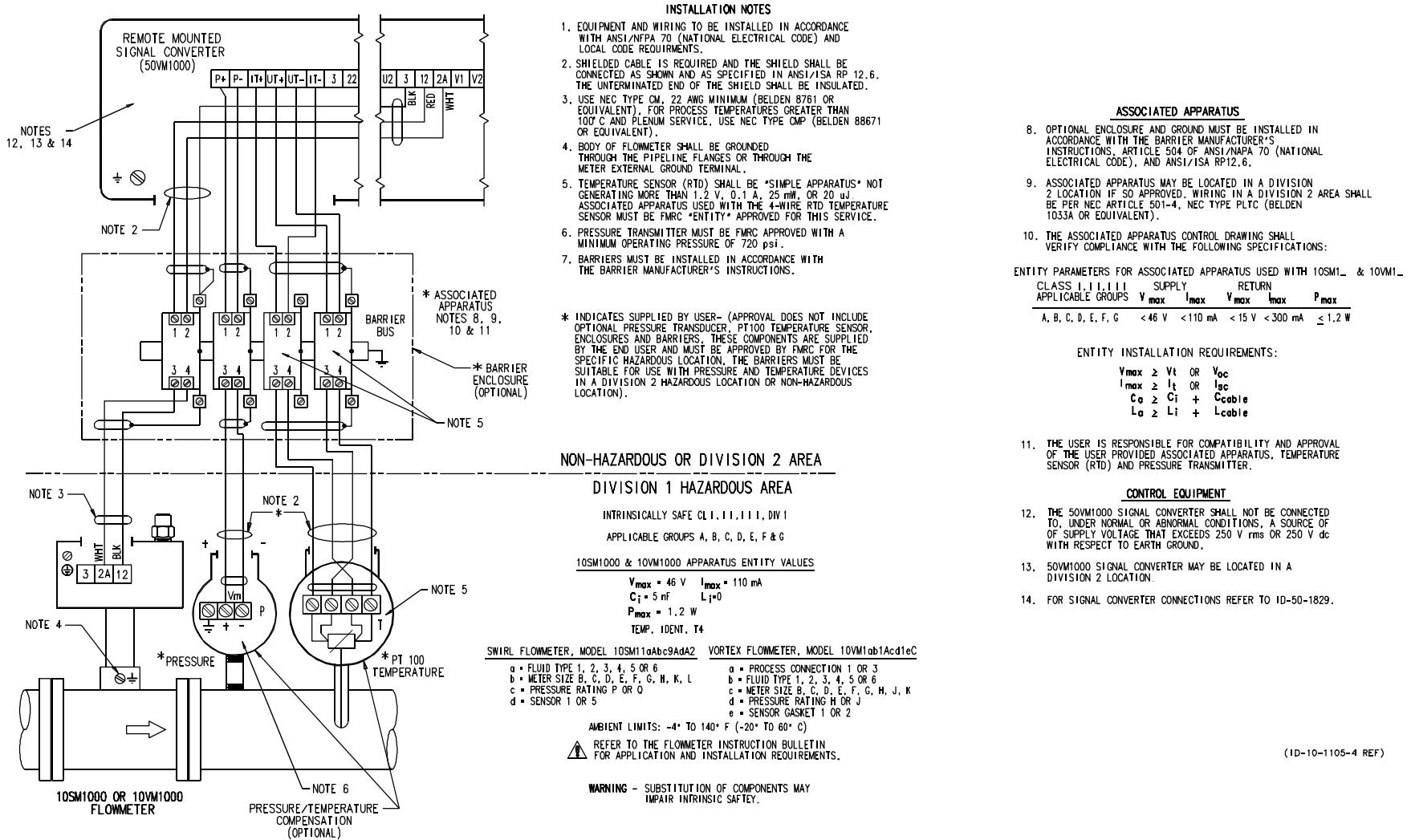

FIGURE 2-8. INTERCONNECTION WIRING DIAGRAM FOR INTRINSICALLY SAFE LOCATIONS

2.7 Preamplifier Board Switches

The programming switches are located on the top side of the Preamplifier Board and are shown shaded in Figure 2-9 below. These switches customize the sensor-signal noise filter characteristics and enable a single preamplifier assembly to adapt to all meter sizes and process media. It is important that these switches be set correctly for proper operation of the meter. The switches are generally preset at the factory and should require no re-adjustment but if a verification of the proper settings is desired, Table 2-2 on the next page correlates the filter switch positions with the applicable meter size and process fluid.

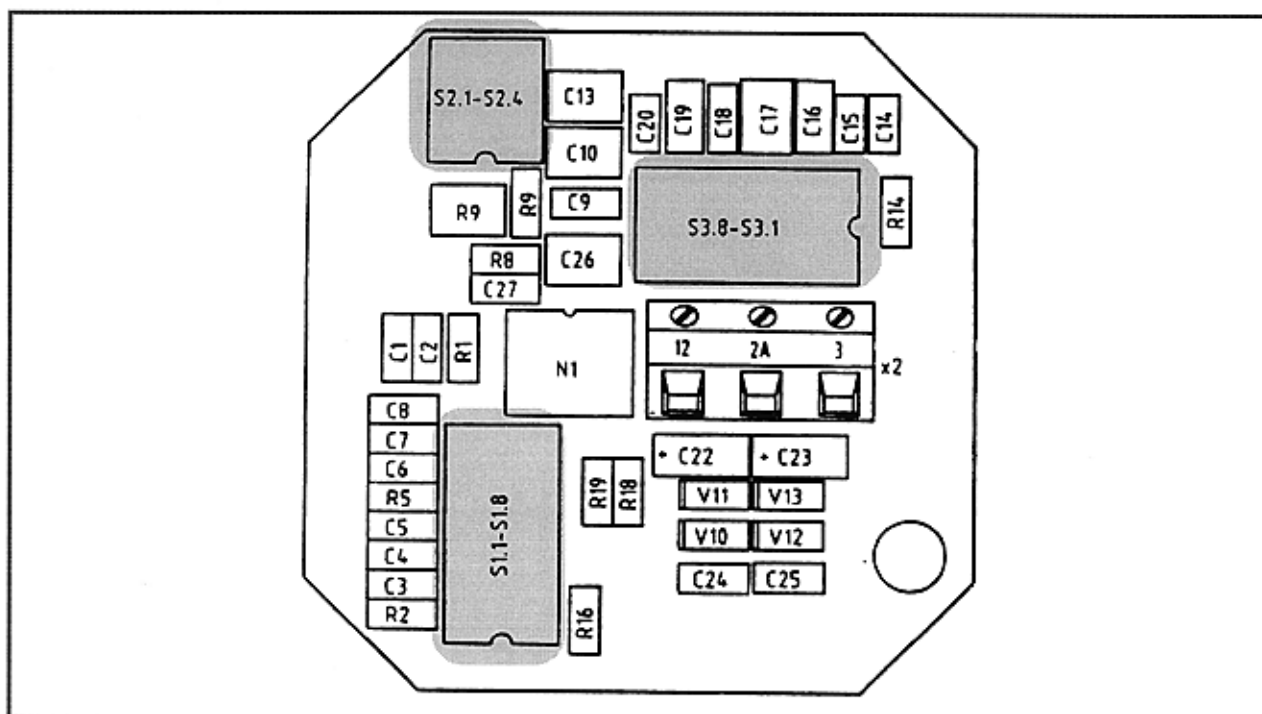

FIGURE 2-9. LOCATION OF PROGRAMMING SWITCHES

2.8 Conduit Seal and Pressure Relief

In accordance with the National Electrical Code (NEC) ANSI/NFPA 70, Article 501-5(f)(3), the flowmeter includes a **conduit entry seal** and **pressure relief** to prevent the process fluid from entering the electrical conduit system. This safety feature considers the remote possibility of a primary seal failure between the meter body and the electronic housing.

The **conduit entry seal** will prevent the process fluid from entering the electrical conduit system. The conduit entry seal consists of a conduit entry cable seal on the meter junction box. **It is the user's responsibility to properly install the conduit entry cable seal fitting supplied with the flow computer interconnection cable.** This will assure proper performance of this safety feature. Refer to Figure 2-10 for proper installation.

A **pressure relief** is provided in the electronics housing for the flowmeter. The pressure relief is located in the center of the cover joint on the side opposite from the conduit connection. If the primary seal should fail, this pressure relief will vent the process, thereby preventing an over pressurization and potentially dangerous failure of the electronics housing. It is the user's responsibility to be aware of this safety feature and to consider the unlikely event of its functioning. Based on knowledge of the process and meter application, the user should consider the use of deflectors to safely direct the vented process.

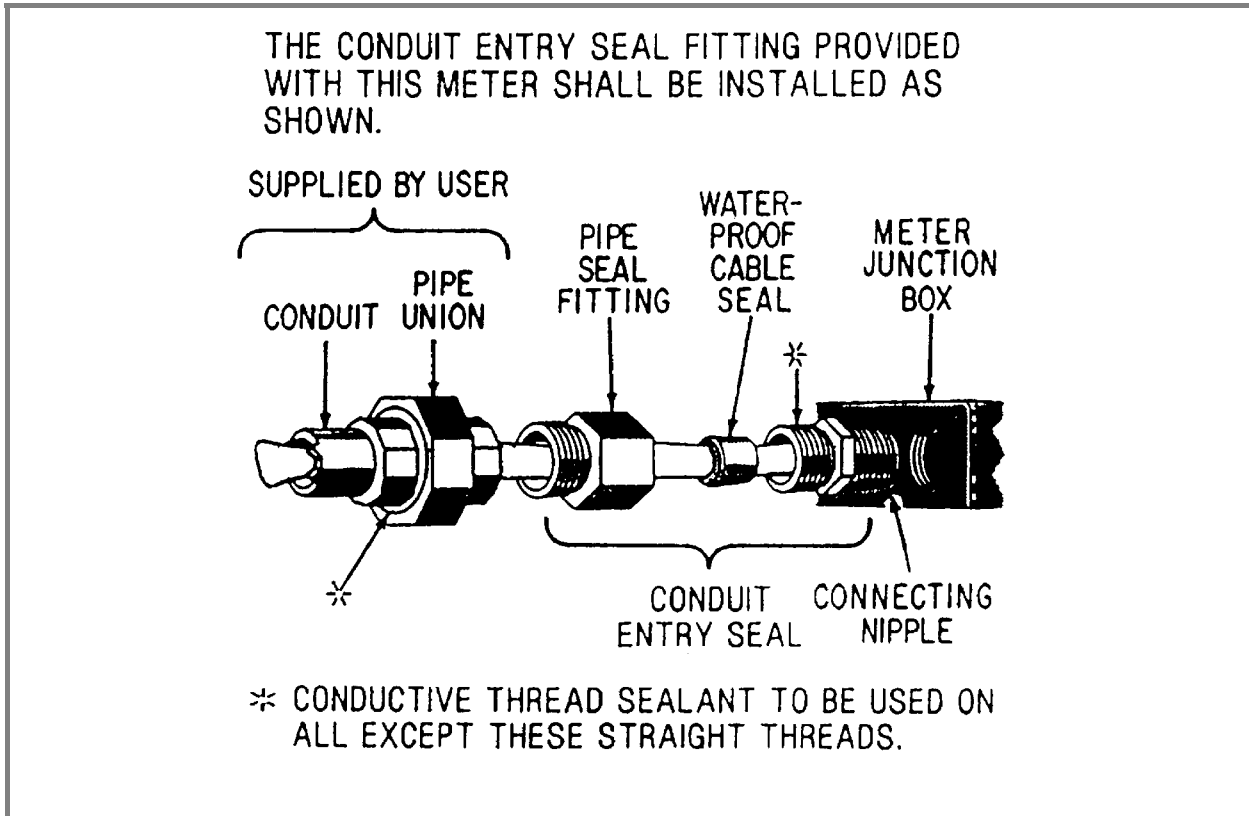

FIGURE 2-10. CONDUIT ENTRY SEAL INSTALLATION

Medium	Meter Size		SWITCHES TO BE IN CLOSED OR "ON" POSITION (ALL OTHER SWITCHES MUST BE OPEN)																				
	in.	mm	S1.1	S1.2	S1.3	S1.4	S1.5	S1.6	S1.7	S1.8	S2.1	S2.2	S2.3	S2.4	S3.1	S3.2	S3.3	S3.4	S3.5	S3.6	S3.7	S3.8	
Gas	.75	20	•	•			•	•			•				•								
	1	25	•	•			•	•			•				•								
	1.25	32	•		•		•		•		•					•							
	2	50	•		•		•		•		•					•							
	3	80	•		•		•		•			•					•						
	4	100			•				•			•					•						
	6	150			•				•				•					•				•	
	8	200				•				•			•					•				•	
	12	300				•				•				•							•		•
	♦ 16	400				•				•				•							•		•
Liquid	.75	20			•				•				•						•			•	
	1	25				•				•			•						•			•	
	1.25	32				•				•			•							•		•	
	2	50				•				•			•							•		•	
	3	80			•	•				•	•			•						•	•		•
	4	100			•	•				•	•	•	•							•		•	•
	6	150			•	•				•	•	•	•	•	•	•	•	•	•	•	•	•	•
	8	200		•	•	•			•	•	•	•	•	•	•	•	•	•	•	•	•	•	•
	♦ 12	300		•	•	•			•	•	•	•	•	•	•	•	•	•	•	•	•	•	•
	♦ 16	400		•	•	•			•	•	•	•	•	•	•	•	•	•	•	•	•	•	•

NOTE: • indicates switch to be in "closed" or "ON" position
 ♦ indicates preliminary settings

TABLE 2-2. PREAMPLIFIER BOARD FILTER SWITCH SETTINGS

3.0 PARTS LIST

TABLE 3-1. FLANGE GASKETS

Meter Size		ANSI Flange Rating	Gasket Part No. (2) required
inches	mm		
.75	20	150	333J083U66
		300	333J083U67
1	25	150	333J089U10
		300	333J089U11
1.25	32	150	333J083U68
		300	333J083U69
2	50	150	333J089U19
		300	333J089U25
3	80	150	333J089U22
		300	333J089U26
4	100	150	333J089U29
		300	333J089U30
6	150	150	333J083U33
		300	333J083U42
8	200	150	333J083U38
		300	333J083U46
12	300	150	N/A
		300	N/A
16	400	150	N/A
		300	N/A

N/A = not available



DOCUMENTATION QUESTIONNAIRE

Your answers to the questions below and other comments assist us in publishing better documentation. If an answer requires explanation please use the space provided. All comments and suggestions become the property of Elsag Bailey Process Automation.

1. Title of Document? **IB 10SM1000 - Rev. 1, PN 24821** _____

2. Does this document meet your needs? _____

3. Is the information:

Easily understandable? _____

Properly organized? _____

Complete? _____

Sufficiently illustrated? _____

OTHER COMMENTS

(Please include page and/or figure number.)

Name _____

Address _____

No postage necessary
if mailed in the U.S.A.

If Bailey employee, please include
department number.

CUT ALONG LINE, FOLD, STAPLE



FOLD 1



NO POSTAGE
NECESSARY
IF MAILED
IN THE
UNITED STATES

BUSINESS REPLY MAIL

FIRST CLASS PERMIT NO. 86 WARMINSTER, PA

POSTAGE WILL BE PAID BY ADDRESSEE:

**BAILEY-FISCHER & PORTER
DEPARTMENT 261 / A2
125 EAST COUNTY LINE ROAD
WARMINSTER, PA 18974**

Attention: Technical Publications

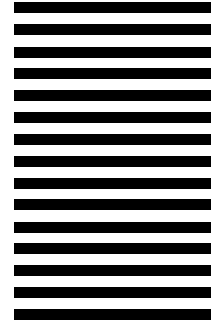

FOLD 2

STAPLE
HERE

Our more than 6,000 professionals worldwide are ready to meet your needs for Strategic Enterprise Management...

Bailey

Australia

Elsag Bailey Pty. Limited
Regents Park, NSW
Telephone: 61-2-645-3322
Telefax: 61-2-645-2212

Belgium

Bailey-Fischer & Porter NV
Wilrijk
Telephone: 32-3-828-05-11
Telefax: 32-3-827-87-28

Brazil

Bailey do Brasil
São Paulo
Telephone: 55-11-548-4122
Telefax: 55-11-547-0315

Canada

Elsag Bailey (Canada), Inc.
Burlington, Ontario
Telephone: 1-905-639-8840
Telefax: 1-905-639-8639

China

Bailey Beijing Controls
Beijing
Telephone: 86-10-401-0651
Telefax: 86-10-401-1643

Finland

Bailey-Fischer & Porter OY
Espoo
Telephone: 358-0-859-3133
Telefax: 358-0-859-3324

France

Elsag Bailey SA
Massy
Telephone: 33-1-64-47-2000
Telefax: 33-1-64-47-2016

Germany

Bailey-F & P Automation GmbH
Overath
Telephone: 49-220-473-90
Telefax: 49-220-473-979

Bailey-Fischer & Porter GmbH

Göttingen
Telephone: 49-551-905-0
Telefax: 49-551-905-777

Italy

Elsag Bailey
Genoa
Telephone: 39-10-658-1
Telefax: 39-10-658-2941

Italy

Fischer & Porter Division
Milan
Telephone: 39-2-927-71
Telefax: 39-2-923-1257

Japan

Bailey Japan Company, Ltd.
Tagata-Gun, Shizuoka-Ken
Telephone: 81-559-49-3311
Telefax: 81-559-49-1114

Jordan

Bailey Controls Jordan
Amman
Telephone: 962-6-788-116
Telefax: 962-6-756-908

Mexico

Bailey Mexico SA de CV
Naucalpan
Telephone: 52-5-557-6100
Telefax: 52-5-557-7022

Netherlands

Bailey-Fischer & Porter Nederland BV
Gorinchem
Telephone: 31-183-69-1111
Telefax: 31-183-69-1177

Norway

Bailey Norge AS
Bergen
Telephone: 47-55-222-000
Telefax: 47-55-222-010

Russia

Bailey Avtomatizatsiya
Moscow
Telephone: 7-502-224-8130
Telefax: 7-502-224-8145

Singapore

Elsag Bailey Pte. Ltd.
Singapore
Telephone: 65-442-3200
Telefax: 65-442-2700

Spain

Bailey-Fischer & Porter España SA
Madrid
Telephone: 34-1-415-2200
Telefax: 34-1-415-3950

Sweden

Bailey-Fischer & Porter Sverige AB
Stockholm
Telephone: 46-8-601-2850
Telefax: 46-8-601-2860

United Kingdom

Bailey Automation plc
Telford, Shropshire
Telephone: 44-1952-670-477
Telefax: 44-1952-670-455

Fischer & Porter Ltd.

Workington, Cumbria
Telephone: 44-1946-830-611
Telefax: 44-1946-833-003

United States

Bailey Controls Company
Wickliffe, Ohio
Telephone: 1-216-585-8500
Telefax: 1-216-585-8756

Bailey-Fischer & Porter Company

Warminster, Pennsylvania
Telephone: 1-215-674-6000
Telefax: 1-215-674-7183

Venezuela

Bailey de Venezuela SA
Valencia
Telephone: 58-41-329-196
Telefax: 58-41-327-632

Turbine Control Systems

Electronic Technology Systems, Inc.
New Kensington, Pennsylvania USA
Telephone: 1-412-335-1300
Telefax: 1-412-335-2450

Energy Management & SCADA Systems

Bailey Network Management
Sugar Land, Texas USA
Telephone: 1-713-274-5000
Telefax: 1-713-240-6986

Liquid Analysis Products

TBI-Bailey Controls
Carson City, Nevada USA
Telephone: 1-702-883-4366
Telefax: 1-702-883-4373

On-Line Process Analysis

Fluid Data, Inc.
Angleton, Texas USA
Telephone: 1-409-849-2344
Telefax: 1-409-849-2166

BAILEY
FISCHER
PORTER

TBI-Bailey



Bailey
Network Management

FLUID
DATA