

IEC 61850 PROCESS CONNECTION – A SMART SOLUTION TO CONNECT THE PRIMARY EQUIPMENT TO THE SUBSTATION AUTOMATION SYSTEM

Christoph Brunner
ABB Switzerland
Zürich, Switzerland
christoph.brunner@ch.abb.com

Abstract – In traditional substation automation systems, the process (switchgear, instrument transformers) is connected with hundreds to thousands of copper wires. The process connection for every substation directly reflects the technology of the primary equipment. IEC 61850 provides a direct communication to the process. The copper wires are replaced by a serial communication. The physical layout of the connections within the substation automation system is reduced to a communication network with only few connections to the process. A process connection according to IEC 61850 provides essential benefits. These benefits are discussed in the paper. However, there are also two main challenges related to that connection: (1) the real time behavior and (2) the accurate synchronization required for the instrument transformers. The paper explains, how IEC 61850 responds to these challenges. At the end, the paper gives some more details about the current status and additional specifications.

Keywords: IEC 61850, process connection, IEC 61850-9-2, UCA international users group

1 INTRODUCTION

In 2003/2004, the international standard IEC 61850 "Communication networks and systems in substations" has been published. The standard is the first global standard for the utility industry. It has been developed based on input from the European experience with substation automation as well as input from the EPRI sponsored project UCA®.

IEC 61850 will replace the mainly vendor specific protocols that have been used in the past with a standardized protocol. But IEC 61850 is much more than just another communication protocol. Besides introducing commercial communication technology in the substation automation system, IEC 61850 incorporates the following features not available so far in substation automation.

- A complete standardized object model of the substation. The control of and the information coming from the process equipment like switchgear, power transformers, instrument transformers and other sensors but also the automation functions like e.g. protection functions are mapped in a standardized object model.
- The substation configuration language (SCL). SCL is used to exchange configuration information of the substation between the different configuration

tools used to specify the substation, to configure the substation automation system and to configure the individual IEDs (intelligent electronic devices).
- The integration of communication interfaces in the process equipment. The copper wires connecting the binary I/Os of the switchgear are replaced by a communication link. The analog output of instrument transformers is as well replaced by a communication link transporting a stream of sampled values. The analog to digital conversion is moved from bay level to process level.

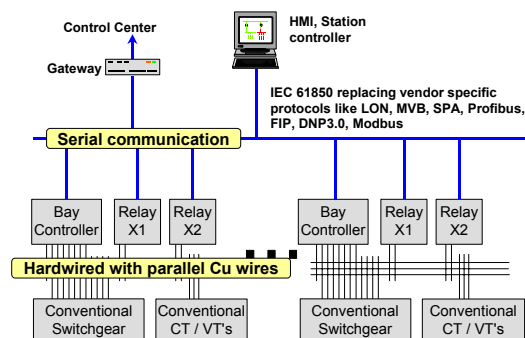

Figure 1: Conventional process connection

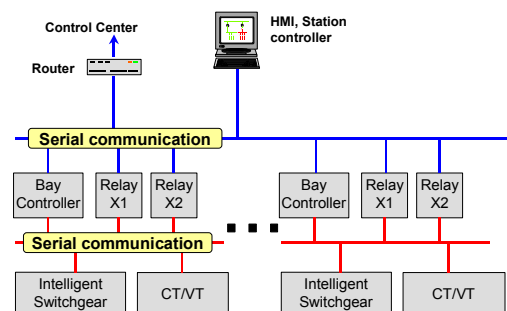

Figure 2: Process connection with serial communication

The connection of the process equipment is the focus of this paper and is further illustrated in the figures above. The first figure shows the conventional connection of the process equipment with copper wires. The

second figure shows the connection with a serial communication as specified in IEC 61850.

2 THE PROCESS CONNECTION AS SPECIFIED IN IEC 61850

2.1 Hiding the technology specific aspects of switchgear

In a traditional process connection, every information point results in a copper wire between the process equipment and typically the bay controller and/or protection device. This is illustrated in the figure below.

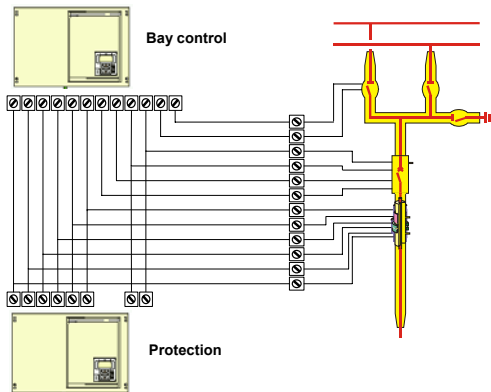

Figure 3: Conventional process connection - details

With that approach, the technology specific details of the switchgear need to be handled in the bay level devices. The bay level device needs to know e.g. how select before operate is handled. It also has to take care for the electrical details of the connection. Engineering and commissioning of the process connection consists of the following steps explained with the example of the connection of a bay controller to the process:

- Determine the number of I/O signals required
- Draw the connection scheme
- Engineer the logical mapping in the bay level equipment between the I/Os and the internal data point / function
- Verify that engineering during the factory acceptance test
- Connect the switchgear contacts to the I/O during commissioning
- Verify these connections during the site acceptance test

The information transfer from one step to the next is typically not automated and involves manual work. The verification of the engineering and connections during factory acceptance tests and site acceptance test comprises a lot of manual work; in particular for the site acceptance test at least two persons are required to verify all the connections.

With the process connection according to IEC 61850 as shown in figure 4, the I/O of the process equipment is connected to IEDs located in the switchgear itself. The IEDs have a communication connection to the bay level equipment. These IEDs handle the technology specific details of the switchgear and the electric details.

The wiring between the IEDs and the process is done and tested during manufacturing. The same applies for the logical mapping between the I/Os and the internal data points. The engineering and commissioning of the process connection is reduced to the following steps:

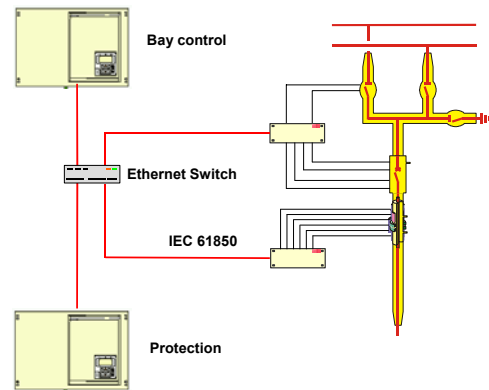

Figure 4: Process connection according to IEC 61850

- Draw the communication network
- Engineer the data flow
- Verify that engineering during the factory acceptance test
- Build the communication network
- Verify the communication network during the site acceptance test

With other words, instead of handling many wired connections during engineering, commissioning and testing, this is reduced to handle a few communication connections. In addition, the information flow between the steps may be automated.

2.2 Connecting instrument transformers

For the conventional connection of instrument transformers, the bay level equipment needs to handle issues like the rated values and the ratio of the transformers. In addition, with new technologies introduced for the instrument transformers (e.g. optical sensors or Rogowski coils), the analog interface to the instrument transformer becomes again very technology specific. The 100V/5A interface is in these cases replaced by a low energy interface or even by an optical interface.

With the serial communication defined in IEC 61850 a stream of digitized samples replaces the analog signal. The representation of the values is independent from any specific properties of the instrument transformer. The values are transmitted with the data type integer or real. In the case of the real representation, the actual process value from the power system without any scaling or rating is transmitted. In the case of the integer representation, the value is scaled; the scaling parameters are included in the data model so that any receiver can calculate the actual process value.

2.3 Some further aspects of a serial communication

Transmitting the data with a bus structure allows that these data may be used by multiple receiving IEDs. This means that the data flow engineering is only an issue of SW configuration compared to the conventional con-

nection, where the data flow is determined by physical wiring. As a consequence, extensions and modification of existing protection and measurement schemes are very simple to realize.

In addition, a communication network inherently supports the continuous supervision of the connection.

2.4 Replacing signal lists with an object model

Not only the way how certain signals like e.g. an opening contact need to be connected may vary from one switchgear equipment to the next. Also the amount of information available may be highly technology dependent. This applies in particular for monitoring information. As an example a circuit breaker with a hydraulic drive may have indications of leakage of hydraulic pressure or of problems with the motor of the hydraulic pump. A circuit breaker with a mechanical spring or with a servomotor may have completely different alarm and warning indications.

In the system with conventional connection to the process equipment, there is not only the need to individually configure all these connections. In addition, in the conventional substation automation system, all information coming from the process remains a loose collection of information identified by anonymous numbers without any functional grouping.

IEC 61850 has introduced an object oriented modeling approach using logical nodes as core objects. A logical node is a functional grouping of information. Logical nodes are standardized in IEC 61850 and have a name that consists of four characters. Basically, there are two categories of logical nodes. The first are the logical nodes that represent the information content of a function internal to the substation automation system. Examples for that are logical nodes for protection functions (e.g. **PDIS**, the logical node for a distance protection function) or measurement (e.g. **MMXU**, the logical node for a measurement unit that provides calculated values like rms voltage or power). The second are the logical nodes that represent the (external) process equipment (external in the sense of external to the automation system). Examples for that are the logical nodes **XCBR** for the circuit breaker or **TCTR** for the current transformer. These logical nodes group all information relevant to the specific process equipment they represent.

Elements of a logical node are called data in IEC 61850. The data have attributes and the attributes finally are representing the information of the process equipment. Data combine the operational attributes and the configuration attributes. As an example, the data **Pos** (position) of the LN **XCBR** combines the attribute to control the breaker (attribute **ctlVal** with the values off / on) and the attribute that provides the status information (attribute **stVal** with the values off, on, intermediate-state, bad-state) with several configuration attributes that can – among other – be used to define the select before operate behavior of the breaker. With that, a sophisticated functional grouping of the information is provided. The information from the process equipment

is available throughout the substation automation system in a standardized and coherent way including the semantic interpretation.

XCBR			
	Data Name	Type	Explanation
Common LN Information	Mode	INC	enable / disable
	EEHealth	INS	ok / warning / alarm
	EEName	DPL	Name plate
	OpCnt	INS	operation counter
Controls values	Pos	DPC	Position (control / status)
	BlkOpn	SPC	Block opening
	BlkCis	SPC	Block closing
	ChaMotEna	SPC	Charger motor enabled
Status information	CBOPCap	INS	op. capability (o-c...)
	POWCap	INS	point on wave capability
	MaxOpCap	INS	maximal op. capability
Extension	TrCoilFail1	SPS	Failure of trip coil 1
	TrCoilFail2	SPS	Failure of trip coil 2
	HydrLeak	SPS	Leakage of hydraulic

Figure 5: Example of a logical node

In order to deal with the technology specific information of the switchgear that can not necessarily be standardised, IEC 61850 defines rules how a logical node may be extended with additional information. In addition, the data model and communication services of IEC 61850 support self-description. With that, it is easy to build a client tool that can browse a device and read out and interpret the information from the device without knowing the details beforehand.

2.5 Device status

As mentioned in the previous clause, there is many technology specific alarm and warning information available from the process equipment. In the case of the conventional connection of that equipment, the bay control device needs to create summary information that determines whether the operation of the device is still safe or not.

In the IEC 61850 object model, this summary information is standardized and created by the process equipment itself. The data "**EEHealth**" (External equipment health) is modeled as a green – yellow – red indication with the following meanings:

- Green (or ok): the equipment is in a good state
- Yellow (or warning): there are some minor problems; operation of the device is still safe but maintenance personal should check the detailed information
- Red (or alarm): there are serious problems; operation of the device is not safe anymore; immediately check the detailed information and send maintenance personal

2.6 Electronic nameplate

Process equipment is equipped with nameplates. These nameplates include information that uniquely identifies the equipment (Manufacturer, product type, serial number) as well as information related to the characteristic of the equipment (e.g. ratings). In some cases, there exist product standards that specify the minimal content of the equipment.

With IEC 61850, that nameplate is available in electronic form as part of the data model. It includes also revision information (SW/HW version). While IEC 61850 defines a generic nameplate to be used for process equipment (**EEName**), IEC 62271-003 defines the nameplate for switchgear as an extension of the IEC 61850 nameplate.

2.7 Taking advantage of these new features

Some of the features of the IEC 61850 based process connection provide an immediate benefit in substation automation systems that have the same functionality as today. Other features facilitate new applications.

The electronic nameplate is very useful for an integrated asset management tool. Instead of relying on paper documentation, such a tool can browse the substation automation system at any time and read out all relevant information of the installed process equipment. When equipment is replaced, the asset manager does not need anymore to rely on getting the updated paper documentation.

Another application that benefits from the new features is a monitoring tool for the power equipment. As already mentioned before, the standardized data **EEHealth** gives a first, generic information on the status of the equipment. If a warning or alarm is issued, an operator using a monitoring tool can browse that equipment to get more details. Due to the self-description, it is possible for the tool to read out the technology specific information, that is not standardized in IEC 61850, without knowing it beforehand and display that information to the operator. Each data has a description attribute, where a text that explains the semantic of the data can be stored. If the process equipment has stored additional technology specific warning and alarms, with the help of such a tool, the operator can easily identify what part of the equipment has caused the problem.

In addition to the information providing more details to the data **EEHealth**, it is of course also possible, to store more monitoring information that can be used for condition based maintenance (e.g. travel curves of the switchgear, gas density history). Also that information can be read out from the equipment by using a vendor independent tool.

2.8 Aspects of system design

An important function of the substation automation system is the protection function. In most cases there are two independent protection systems called main 1 and main 2 protections. With a conventional process connection, this is easily achieved by having two protection relays that are individually connected to the process equipment.

The same level of independency needs of course be achieved when using a process connection according to IEC 61850. That requires the duplication not only of the IEDs in the process equipment but also at least part of the communication system. This is considered in the

architectural considerations for the use of IEC 61850 as process connection.

3 THE CHALLENGES OF A DIGITAL PROCESS CONNECTION

The previous clause has shown us some of the benefits from the IEC 61850 process connection. However, implementing a process connection based on commercial communication technology comprises also some challenges. In this clause, these challenges will be discussed.

3.1 The real time behavior

The information exchange between the process equipment and the substation automation is subject of high requirements regarding the real time behavior. The most critical information exchange is the one related to protection i.e. the transmission of the sampled values from the instrument transformers to the protection relay and the transmission of the trip command from the relay to the circuit breaker. According to IEC 61850-5, the acceptable maximal communication delay is for the highest class as few as three milliseconds. This has to be achieved independent from the load of the communication network.

The communication stack for client-server communication specified in the mapping defined in IEC 61850-8-1 and IEC 61850-9-2 is MMS over TCP/IP and Ethernet. Ethernet as known from the office environment would not fulfill the requirements of a process connection. However, trends to use Ethernet as well in the factory automation have lead to the development of Ethernet extensions that provide the real time capability. IEC 61850 is using switched Ethernet to avoid collisions. The time critical messages are not routable and are directly mapped on the link layer. With the additional use of priority tagging and full duplex connections to the switch for the devices with time critical information, the real time requirements can be fulfilled.

The figure below shows the principals of the mapping. The aspect of the real time behavior is discussed in more details in [2] and [3].

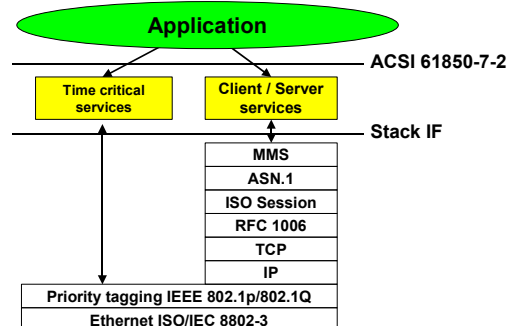

Figure 6: The communication stack

3.2 The accurate time synchronization

An important aspect while using sampled values of a power system is the phase relationship between the different measured signals, in particular between current and voltage. For some applications, the accuracy in the time domain needs to be in the range of one microsecond. That means, when samples are acquired in different devices, the relation to the time base must be with an inaccuracy of less than one microsecond.

There are basically two solutions for that problem. The first is the approach of a constant acquisition delay. In that case, the delay from the acquisition of the sampled value (the moment, where the value is sampled at its source) until the reception in the data sink (e.g. the protection equipment) needs to be constant and known with a jitter below the required accuracy. The receiving unit can then put the values in a time relation to each other based on the reception time and the known delay.

The second approach is to use synchronized or time related sampling. All units performing sampling are globally synchronized with the required accuracy. The samples are either taken all at the same time or the samples are tagged with a time stamp indicating their sampling time. Only that approach can deal with variable communication delays, as they are inevitable when using a network topology for the communication. Therefore, IEC 61850 has chosen this approach. According to the concepts of IEC 61850, the samples are all taken at the same time and each sample is identified with a number that provides the time reference. The approach is illustrated in the figure below.

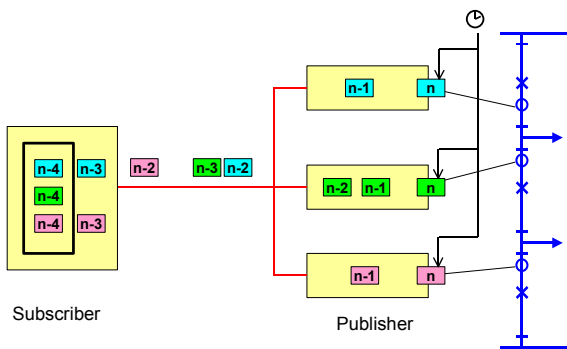

Figure 7: The approach to transmit sampled values

The challenge here is to synchronize the devices performing the sampling with accuracy in the range of 1 microsecond. IEC 61850-9-2 that defines the mapping for the transmission of the sampled values assumes an external signal to synchronize the devices. In today's implementations [4], a 1PPS (one pulse per second) signal is used to synchronize the devices. This requires in addition to the communication network a synchronization network.

Such an additional synchronization network is of course a source of failure. However, not all functions depend on these high synchronization requirements. And the mission critical functions do not need informa-

tion from many different acquisition points. With elaborated system architecture, the dependency of the critical functions from the synchronization network can be removed.

Still, for the future, a synchronization that is not using an additional network is desirable because it provides much more flexibility for the system architecture. With IEEE 1588 / IEC 61588, there is now a standard available, that supports time synchronization over the Ethernet and across switches with an accuracy in the sub-microsecond range. As soon as this standard will be implemented in the Ethernet switches, the IEC working group 10 of TC57 that is responsible for IEC 61850, will consider amending the current edition of the standard in order to use IEEE 1588 for the synchronization of the units performing the sampling.

3.3 Reliability

Introducing the communication interface in the process equipment means also adding electronics in a harsh environment. This can of course have an impact on the overall reliability of the system. Besides of a diligent design of the electronic equipment, system architecture and function integration are some of the keys to master that challenge. This has been discussed in [1].

4 WHERE ARE WE TODAY?

While IEC 61850 has provided the foundation for a connection of the process equipment with a digital communication, there are several motions, to make this really happen.

4.1 Product standard for switchgear with IEC 61850 interface

The working group 11 of IEC SC17C is preparing the standard IEC 62271-003, "High voltage switchgear and assemblies with digital interfaces based on IEC 61850". This is a product standard for switchgear with the process connection according to IEC 61850.

That standard is the basis for switchgear products in the scope of this paper. To be mentioned here are two issues, that this standard defines. One is the standardisation of the nameplate for switchgear; the other is the specification of logical nodes for monitoring information. It is foreseen to integrate the logical nodes for monitoring information in a future revision of IEC 61850.

Another aspect covered by that standard is the support of communication services. IEC 61850 is providing a set of communication services that can or cannot be supported by the different devices. For the purpose of the IEDs in the switchgear, IEC 62271-003 defines three conformance classes. As an example, conformance class (a) that is the minimal requirement specifies the transmission and reception of GOOSE messages as mandatory. Conformance class (c) requires the full support of all services. An IED according to IEC 62271-003 has to declare the conformance class it supports.

4.2 Implementation guideline for instrument transformers

In order to support a fast market introduction of instrument transformers with a digital interface according to IEC 61850-9-2, several vendors and utilities have prepared an implementation guideline [4]. The UCA international users group published the implementation guideline. The implementation guideline defines a subset of IEC 61850-9-2 that facilitates first implementations especially in existing products.

While in IEC 61850 the information that is combined in one message of the sampled value transmission is configurable, the implementation guideline defines the content to include the three phase voltages, the three phase currents and neutral current and voltage. The IED interfacing the current and voltage transformers is called merging unit and is shown in the figure below.

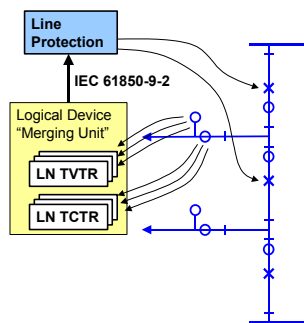

Figure 8: The concept of a merging unit

4.3 Prototyping and pilot projects

The concepts of the process connection according to IEC 61850 have been verified in a couple of prototyping activities and interoperability demonstrations [2, 3]. These activities have supported the standardization process.

In the meantime, the implementation in the first products has started. With regard to the process connection, the focus in a first step is on the digital interface between non-conventional sensors (optical or Rogowski coils) and protection equipment. First pilot projects with non-conventional sensors and an IEC 61850 connection

to protection relays and meters are installed in France (EDF), Netherlands (TenneT) and UK (National Grid). In the US, a research project with planned field installations to investigate the feasibility of an all digital protection system using optical instrument transformers directly interconnected through IEC 61850-9-2 with digital relays is scheduled to start in summer 2005.

5 CONCLUSIONS

The standard IEC 61850 for communication in substations provides also a standardized serial link between the process level (switchgear, instrument transformers, etc.) and the bay level (control, protection, etc.). Tests have proven such a solution. The selected communication stack fulfills the real-time requirements. Further improvements can be achieved by integrating IEEE 1588. Using this standard replaces not only a lot of wires by one or some few fibers but allows also to use any process technologies e.g. for instrument transformers without changing the relays. Changing connection schemes means besides moving some connectors only software changes. Supervision and testing is simplified. All the information provided by the standardized data from the process supports supervision and asset management over the complete information and control chain.

REFERENCES

- [1] L. Andersson, Ch. Brunner and F. Engler, "Substation automation based on IEC 61850 with new process-close technologies", IEEE Powertech Bologna, June 2003
- [2] Ch. Brunner, G. Schimmel and H. Schubert, "Standardization of serial links replacing parallel wiring to transfer process data – approach, state and practical experience", CIGRE 2002 Paris, August 2002
- [3] F. Engler et al, "IEC 61850 based digital communication as interface to the primary equipment", CIGRE 2004 Paris, Paper B3-205, August 2004
- [4] "Implementation guideline for digital interface to instrument transformers using IEC 61850-9-2", UCA international users group (www.ucainternational.org)