

FACTS for Grid Integration of Wind Power

Rolf Grünbaum, *Senior Member, IEEE*

Abstract—Integrating renewables into grids to any considerable degree can expose the system to issues that need attention lest the functionality of the grid be impaired. Such issues can be voltage fluctuations, frequency deviations, and deterioration of power quality. By utilization of FACTS devices such as SVC, STATCOM, and Series Capacitors, grid function can be maintained and even improved, enabling increased power transmission capacity over existing lines. Renewable power such as wind and solar can then be accommodated in the grid without any need for building new lines. Dynamic Energy Storage, a newcomer to the FACTS family, offers additional possibilities such as back-up for renewable generation, storage of renewable energy for release during periods of higher demand, and area frequency regulation. The paper offers some salient design features of FACTS, as well as highlights a few current cases where FACTS devices are put to use to enable or improve grid integration of renewable energy sources.

Index Terms—Area frequency control, Dynamic energy storage, Dynamic voltage control, Dynamic voltage stability, Power quality, Power transmission capacity, Reactive power compensation, Series compensation, Transient stability.

I. NOMENCLATURE

FACTS	Flexible AC Transmission Systems
IGBT	Insulated Gate Bipolar Transistor
PCC	Point of Common Coupling
PWM	Pulse Width Modulation
STATCOM	Static Compensator
SVC	Static Var Compensator
VSC	Voltage Source Converter
WTG	Wind Turbine Generator

II. INTRODUCTION

THE dominating kind of wind power generation is asynchronous, this since it is robust and cost effective. Induction generators, however, do not contribute to regulation of grid voltage, and they are substantial absorbers of reactive power. Ideally, they need to be connected to stiff grids in order not to influence stability or power quality in a detrimental way. This is usually not the case, however. Quite the contrary, wind power is usually connected far out in the grid, on sub-transmission or distribution levels, where the grid was not originally designed to transfer power from the system extremities back into the grid.

The reactive power balance of asynchronous generators

can be improved by use of the doubly-fed rotor concept (DFIG). To keep this technology within reasonable cost margins, however, rotor converter ratings must be kept limited mostly to steady-state requirements. During transient occurrences in the grid, the performance of DFIGs may well prove inadequate to safeguard primarily voltage stability of the grid, possibly even with a necessity to crowbar the rotor converters to protect them from overload. In a situation like that, the DFIG will basically be reduced to a common induction generator. Here, dynamic reactive power support from FACTS in the point of common coupling (PCC) can improve the situation greatly.

For off-shore wind generation, comprehensive AC sea cable networks add another dimension, calling for additional elaborate reactive power control. The overall scope of reactive power control should encompass the wind farm just as well as the sea cables, to bring about a well regulated reactive power balance of the whole system, answering to the same demands on reactive power regulation as any other medium to large generator serving the grid.

III. FACTS

FACTS make up a family of high power devices that are applied in power systems in shunt and/or in series.

FACTS solutions are particularly justifiable in applications requiring rapid dynamic response, ability for frequent variations in output, and/or smoothly adjustable output [1]. Under such conditions, FACTS is a highly useful option for enabling or improving the utilization of power systems.

FACTS devices can basically be sub-divided into three categories:

- Shunt devices such as SVC (Static Var Compensator) and STATCOM¹
- Series devices such as Series Capacitors and Thyristor Controlled Series Capacitors (TCSC)
- Dynamic Energy Storage devices.

With FACTS, a number of valuable benefits can be attained in power systems:

- *Dynamic voltage control*, to enable limiting of over-voltages over long, lightly loaded lines and cable systems, as well as prevent voltage depressions or even collapses in heavily loaded or faulty systems.
- *Increased power transmission capability and stability*, without any need to build new lines. This is a highly attractive option, costing less than new lines, with less time expenditure or environmental impact.

R. Grünbaum is with ABB AB, FACTS, SE-721 64 Västerås, Sweden (e-mail: rolf.grunbaum@se.abb.com).

¹ Also known as SVC Light[®]

- *Facilitating integration of renewable power* by maintaining grid stability and fulfilling grid codes, as well as making room for this additional power in existing grids.

Applications treated in this paper are involving SVC, Series Capacitors, STATCOM, and Dynamic Energy Storage.

IV. GRID REQUIREMENTS

Grid Codes are issued by grid companies, spelling out the rules that apply for anyone who wishes to connect a wind farm to the grid. Main requirements involve:

- Reactive power supply
- Fault ride-through capability
- Voltage control
- Power quality control (flicker, harmonics)
- Frequency control,

some or all of which may require FACTS at the PCC to satisfy the demands (Fig. 1).

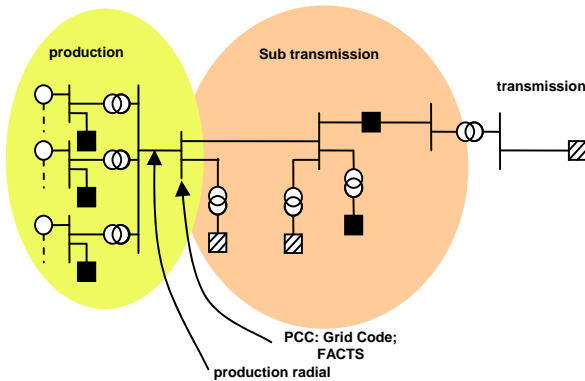

Fig. 1. Grid connection of a wind farm.

At what level in the grid the wind farm is best connected (distribution/sub-transmission/transmission) naturally depends on the size of the wind farm, as the power input from the farm must be accommodated within the power transmission capability of the grid. Against this background, as an example, the Swedish National Grid has issued the following guide rules concerning grid connection of wind farms:

- To be connected to transmission level (220 kV or higher): rated power $P \geq 100$ MW;
- To be connected to 400 kV: rated power $P \geq 300$ MW

In the course of the coming years, a number of large or very large wind farms (100 MW up to several hundred MW per wind farm) are expected to come on line in Sweden. To alleviate the need for new and costly transmission lines over long distances, and to enable extended use of existing facilities, FACTS devices such as SVC and Series Capacitors should come into the picture in a natural way.

A. Reactive power provision

As sources of generation, large wind farms are required to be able to provide reactive power at the PCC basically to the same extent as traditional generation such as fossil, hydro and

nuclear, i.e. over a continuous range from lagging to leading power factor. As an example, the German e.on Rules of Grid Connection concerning reactive power provision (power factor range) are shown in Fig. 2 [2].

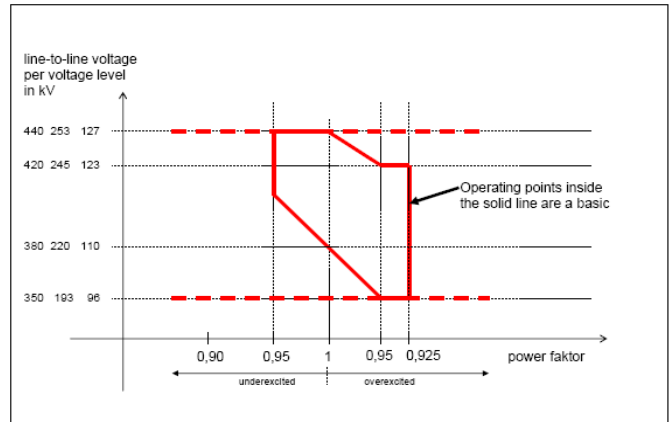

Fig. 2. Grid Code requirements: reactive power provision.

To the extent that this cannot be fulfilled by means of the wind farm itself, an SVC or SVC Light at the PCC can be of assistance to regulate reactive power in a smooth, continuous way.

In cases of off-shore wind farms, where AC is utilized to bring the power to shore, the sea cable(s) must be included in the overall picture, as well, as the reactive power generated in the cable(s) will influence the power factor at the PCC. With FACTS, this can be accommodated in a natural way, for all operating situations of the wind farm, including the case where the wind farm is idle or even disconnected (Fig. 3).

In fact, AC is the predominant way of landing power from off-shore wind farms. In Denmark alone, two off-shore wind farms, each rated at more than 150 MW are connected to shore by means of AC. With modern PEX cables, the break-even distance between AC and DC lies beyond 100 km.

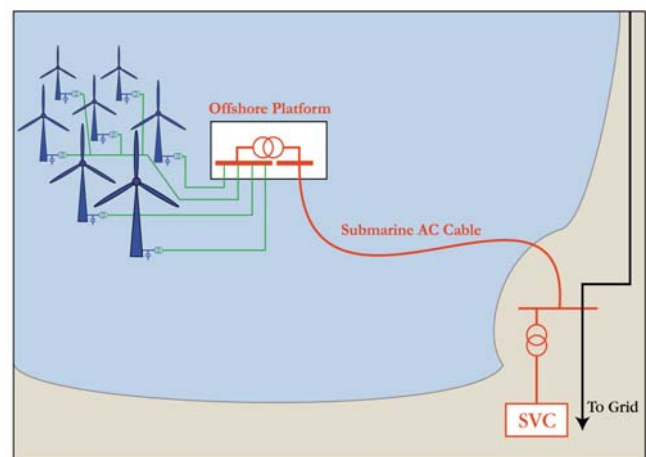

Fig. 3. FACTS and off-shore wind power.

B. Fault ride-through capability

Regarding fault ride-through, the e.on grid code stipulates that the wind turbine generator (WTG) must stay connected

for a close-up 3-phase fault in the transmission system that is cleared within normal protection operating times (150 ms). Mechanical power output during and after the fault has been cleared must not be significantly reduced (Fig. 4).

The WTG must remain stable throughout, which calls for fast re-magnetisation of the WTG when the grid voltage returns after the fault.

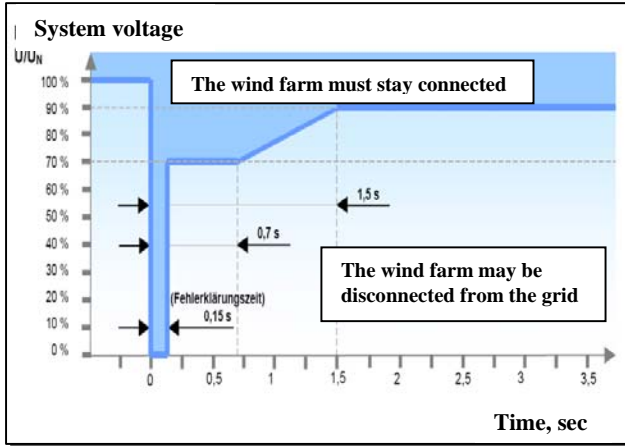

Fig. 4. Grid Code requirements: fault ride-through capability.

With SVC, the need for fast injection of reactive power upon fault clearing is readily satisfied. With SVC Light (STATCOM), even faster response is attained. This is treated further on in the paper.

V. SVC

In a wind power application, the SVC has up to several of the following tasks to fulfil at the PCC:

- Steady-state and dynamic voltage stabilization
- Continuous power factor control
- Aiding fault ride-through of the wind farm
- Power quality control by mitigation of flicker (caused by tower shadow effect, fluctuating wind, and/or starts and stops of WTGs); also harmonic reduction and reduction of phase imbalance.

A. Some basic design features

An SVC is based on thyristor controlled reactors (TCR), thyristor switched capacitors (TSC), and/or harmonic filters. Two common design types, each having its specific merits, are shown in Fig. 5a and 5b.

A TCR consists of a fixed shunt reactor in series with a bi-directional thyristor valve. TCR reactors are as a rule of air core type, glass fibre insulated, and epoxy resin impregnated.

A TSC consists of a capacitor bank in series with a bi-directional thyristor valve and a damping reactor which also serves to de-tune the circuit to avoid parallel resonance with the network. The thyristor switch acts to connect or disconnect the capacitor bank for an integral number of half-cycles of the applied voltage. The TSC is not phase controlled, which means it does not generate any harmonic distortion.

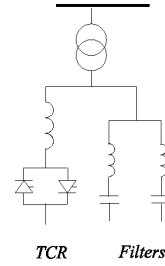

Fig. 5a. TCR/Filter configuration.

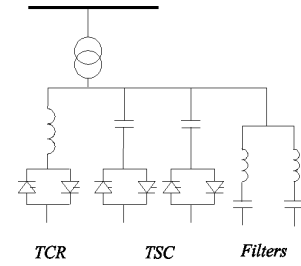

Fig. 5b. TCR / TSC/Filter configuration.

A complete SVC based on TCR, TSC and harmonic filters may be designed in a variety of ways, to satisfy a number of criteria and requirements in its operation in the grid. In addition, slow vars by means of Mechanically switched capacitors (MSC) can be incorporated in the schemes, as well, if required.

B. SVC characteristics

An SVC has a voltage-current (VI) characteristic as in Fig. 6. The SVC current/susceptance is varied to regulate the voltage according to a droop characteristic, or slope. The slope setting is important in coordination with other voltage control equipment in the grid. It is also important in determining at what voltage the SVC will reach the limit of its control range. A large slope setting will extend the active control range to a lower voltage, but at the expense of voltage regulation accuracy.

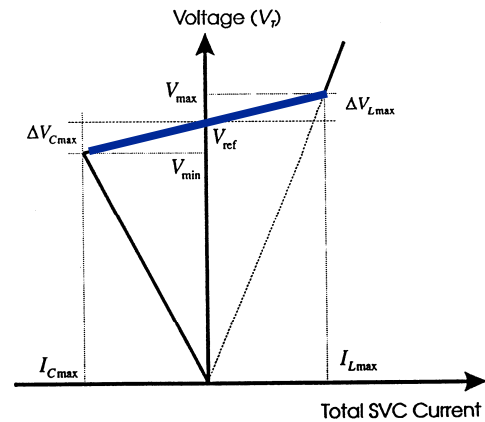

Fig. 6. SVC V-I characteristic.

C. Control system

The primary objective of the control system is to determine the SVC susceptance needed in the point of connection to the power system, in order to keep the system voltage close to the desired value. This function is realised by measuring the system voltage and comparing it with a set (reference) value. In case of a discrepancy between the two values, the controller orders changes in the susceptance until equilibrium is attained.

The controller operation results in a susceptance order from the voltage regulator which is converted into firing orders for each thyristor. The overall active SVC susceptance is given by the sum of susceptances of the harmonic filters, the

continuously controllable TCR, and the TSC if switched into operation. The control system also includes supervision of currents and voltages in different branches. In case of need, protective actions are taken.

D. Thyristor valves

The thyristor valves consist of single-phase assemblies (Fig. 7). The thyristors are electrically fired. The energy for firing is taken from snubber circuits, also part of the valve assembly. The order for firing the thyristors is communicated via optical light guides from the valve control unit located at ground potential.

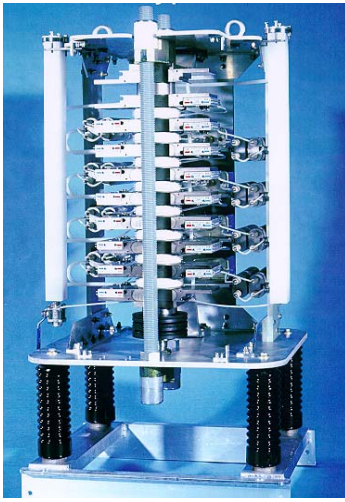

Fig. 7. Thyristor valve of BCT design (one phase out of three).

Between thyristors, heat sinks are located. The heat sinks are connected to a water piping system. The cooling media is a low conductivity mixture of water and glycol. The TCR and TSC valves each comprise a number of thyristors in series, to obtain the voltage blocking capability needed for the valves.

In the most recent SVCs supplied, the thyristor valves are equipped with Bi-Directional Control Thyristors (BCT). In such devices, two thyristors are integrated into one wafer with separate gate contacts. Thus, the valves comprise only one thyristor stack in each phase instead of two, which enables considerable compacting of the valve design.

E. A current example

In Western Texas, there is an abundance of wind power. In one hub, located in the McCamey area south of Odessa, wind production has grown to 750 MW and is expected to grow to well over 1 GW in the next few years. This corresponds to some 80% wind power penetration. In a second hub, the Central area located south of Abilene, 1000 MW of wind power is installed.

The transmission system in the McCamey area is basically two 138 kV lines providing parallel paths for the wind power delivery into the 345 kV system supplying the Dallas-Fort Worth area, a major load center. With either of these lines out, a substantial increase in reactive losses will occur, leading up to voltage stability problems. Correspondingly, the Abilene

hub causes a significant power flow across the 345 kV transmission system towards the Dallas-Fort Worth area. Contingencies in the 345 kV network will load up the underlying 138 kV system, which will have to carry a portion of the power diverted from the 345 kV line lost in the outage.

For these situations, adequate dynamic reactive power support is necessary to maintain system operation at acceptable voltage levels. To improve and maintain system voltage stability in the McCamey and Abilene areas, three SVCs have been installed in the system, each rated at 40 Mvar inductive to 50 Mvar capacitive (-40/+50 Mvar). Two of these, located at Crane and Rio Pecos substations south of Odessa, are connected directly to 69 kV without any need for step-down transformers. The third, located at Bluff Creek close to Abilene, is connected to the 34.5 kV tertiary winding of an existing 345/138 kV autotransformer.

The concept of medium size SVC units distributed to critical buses in the system was chosen by the grid owner for the ability to apply the dynamic support close to the wind power connection points. This yields effective reactive power support during post fault system conditions and maximizes the power transfer capability out of the wind farm areas during shifting wind conditions.

The single-line diagram (Fig. 8) shows the SVCs installed at Crane and Rio Pecos, each rated at 69 kV, -40/+50 Mvar. It comprises a TCR rated at 90 Mvar and three parallel harmonic filters tuned to the 5th, 7th, and 13th harmonics, yielding altogether 50 Mvar at grid frequency (60 cycles).

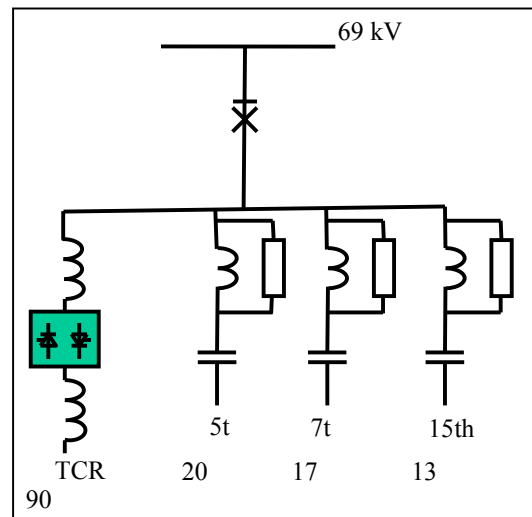

Fig. 8. Single-line diagram, Crane and Rio Pecos 69 kV, -40/+50 Mvar SVC.

Each SVC also has the ability to control up to five external mechanically switched shunt capacitors and reactors. In addition to enhancing the overall dynamic stability, this approach also enables implementation of large sized shunt elements, as the number of switching operations is minimized. These factors added together have given an extremely cost effective Static Var System and also helped improve the project's total cost effectiveness [3].

A site picture of the Crane 69 kV SVC is shown in Fig. 9.



Fig. 9. Crane 69 kV, -40/+50 Mvar SVC.

F. A comparison

In the given example, a comparison between the case benefiting from SVC and a base case without SVC suggests that to attain adequate system stability without SVC would most probably require comprehensive reinforcing of the grid by means of building additional transmission lines and/or upgrading the existing system to higher voltages. That would induce far higher costs as well as much longer implementation times. As conclusion, the chosen technology represents an attractive solution to the grid stability problem.

VI. SERIES COMPENSATION

Series compensation has been utilized for many years with excellent results in AC power transmission in a number of countries all over the world [4]. The usefulness of the concept can be demonstrated by the well-known expression relating to active power transfer P:

$$P = U_1 U_2 \sin \psi / X \quad (1)$$

Here, U_1 and U_2 denote the voltages at either end of the interconnection, whereas ψ denotes the angular difference of the said voltages, and X is the transmission circuit reactance.

From (1) it is evident that the flow of active power can be increased by decreasing the effective series reactance of the line. In other words, if a reactance of opposite sign (i.e. a capacitive reactance) is introduced in the denominator, a corresponding increase in power transmission is enabled without having to increase the angular separation of the end voltages, i.e. with the angular stability of the link unimpeded.

Similarly it is demonstrated that by introducing a capacitive reactance in the denominator of (1), it is possible to achieve a decrease of the angular separation with power transmission capability unaffected, i.e. an increase of the angular stability of the link (Fig. 10).

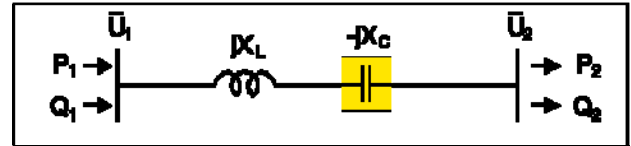

Fig. 10. Series compensated power transmission circuit.

The usefulness of series compensation in conjunction with wind power can be expressed as follows:

- Enabling large amounts of wind power to be transmitted over large geographical distances with less overhead lines needed to be built than would otherwise be required
- In cases where wind power is to be connected to already existing grids, more room is made available in the grid for transmission of wind power under stable conditions.

A. Some basic design features

Of course, a series capacitor is not just a capacitor in series with the line. For proper functioning, series compensation requires control, protection and supervision to enable it to perform as an integrated part of a power system. Also, since the series capacitor is working at the same voltage level as the rest of the system, it needs to be fully insulated to ground.

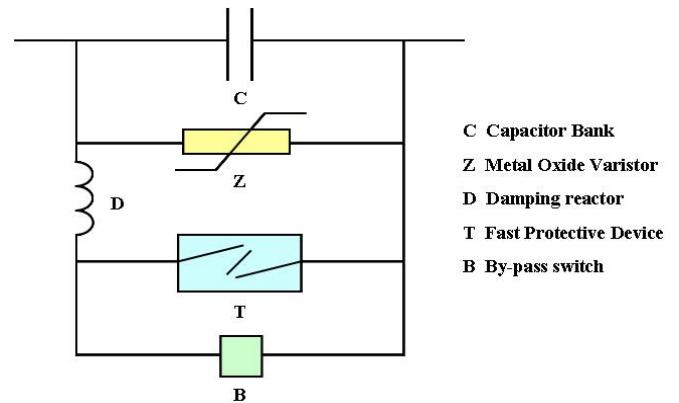

Fig. 11. Series capacitor scheme.

The main circuit diagram of a series capacitor is shown in Fig. 11. The main protective device is a varistor (Z), usually of ZnO type, limiting the voltage across the capacitor to safe values in conjunction with possible system faults giving rise to large short circuit currents flowing through the line.

A Fast Protective Device² (T) is utilized in many cases, to enable by-pass of the series capacitor in situations where the varistor is not sufficient to absorb the excess current during a fault sequence.

A bypass switch (B) is incorporated in the scheme to enable bypassing and insertion of the series capacitor as need may be. It is also needed for relieving the Fast Protective Device, or, in the absence of such, for by-passing the varistor

² CapThor™ is a very fast protective device for series capacitors, replacing conventional spark gaps, and consisting of an arc plasma injector followed by a very fast closing mechanical contact.

in conjunction with faults close to the series capacitor.

Finally, a Damping Circuit (D) is incorporated in the scheme. The purpose of D is to limit and damp the high frequency discharge current which arises when the Fast Protective Device operates or the bypass switch is closed. The high frequency discharge current must be limited and damped to be within the withstand capabilities of the man circuit equipment of the Series Capacitor.

B. A current example

A series capacitor is to be commissioned in the 345 kV power transmission grid near Abilene, Texas, at the location of a very large wind farm (750 MW, and intended to grow further). The series capacitor, rated at 400 Mvar, has the task of increasing the power transmission capacity over a 200 mile (320 km), 345 kV inter-connector bringing power from the wind farm to a consumer area further to the south.

The series capacitor (Fig. 12) is rated for an active power transfer of 925 MW over the 345 kV interconnector.



Fig. 12. Wind farm and 345 kV Series Capacitor, Texas.

C. A comparison

A comparison between the series compensated case and the base case without series compensation reveals that to attain the additional power transmission capacity of the 345 kV line needed to transfer the wind power under stable conditions, a second, parallel line would have been required. Obviously, the series capacitor is the more attractive option, from a cost point of view, just as well as from an implementation time point of view.

VII. STATCOM

SVC Light[®] is a STATCOM type of device, based on VSC (Voltage Source Converter) technology and equipped with IGBTs (Insulated Gate Bipolar Transistor) as semiconductors. A typical voltage-current characteristic of an SVC Light is shown in Fig. 13.

It is worth pointing out that the SVC Light is capable of yielding a high reactive input to the grid more or less unimpeded by possible low grid voltages, and with a high

dynamic response. This is highly useful to improve the fault ride-through capability of a wind farm, where otherwise the returning voltage upon fault clearing would be depressed.

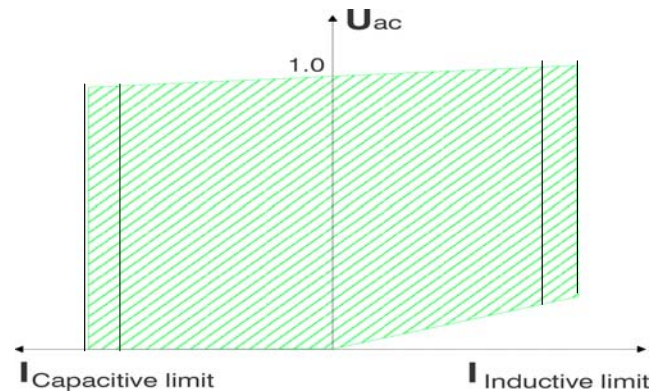

Fig. 13. SVC Light voltage/current characteristic.

From a practical point of view, SVC Light brings further benefits such as:

- Reduced area requirements, due to the replacing of passive reactive components by compact electronic converters;
- Modular, factory assembled units, reducing site works and commissioning time and costs;
- Natural relocatability, due to modular, compact design as well as low harmonic interaction with the grid.

A. Voltage source converter

The function of a VSC is a fully controllable voltage source matching the system voltage in phase and frequency, and with an amplitude which can be continuously and rapidly controlled, so as to be used as the tool for reactive power control (Fig. 14) [5]. In the system, the VSC is connected to the system bus via a small reactor. With the VSC voltage and the bus voltage denoted U_2 and U_1 respectively, it can be shown that the output of the VSC can be expressed as follows:

$$P = \frac{U_1 U_2}{X} \sin \delta \quad (2)$$

$$Q = \frac{U_1 U_2}{X} \cos \delta - \frac{U_1^2}{X} \quad (3)$$

Where:

- P: Active power of the VSC
- Q: Reactive power of the VSC
- U_1 : Bus voltage
- U_2 : VSC voltage
- δ : Phase difference between the voltages
- X: Reactance of the coupling reactor.

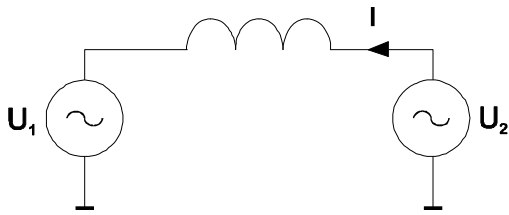

Fig. 14. VSC: a controllable voltage source.

From (2) and (3) it can be seen that by choosing zero phase shift between the bus voltage and the VSC voltage ($\delta = 0$), the VSC will act as a purely reactive element. (In reality, a small phase shift is allowed, in order to make up for the VSC losses.) It is further seen that if $U_2 > U_1$, the VSC will act as a generator of reactive power, i.e. it will have a capacitive character. If $U_2 < U_1$, the VSC will act as an absorber of reactive power, i.e. it will have an inductive character.

B. Converter valve

A VSC of three-level configuration is built up as in Fig. 15. One side of the VSC is connected to a capacitor bank, which acts as a DC voltage source. The converter produces a variable AC voltage at its output by connecting the positive pole, the neutral, or the negative pole of the capacitor bank directly to any of the converter outputs.

By use of Pulse Width Modulation (PWM), an AC voltage of nearly sinusoidal shape can be produced without any considerable need for harmonic filtering. This contributes to the compactness of the design, as well as robustness from a harmonic interaction point of view.

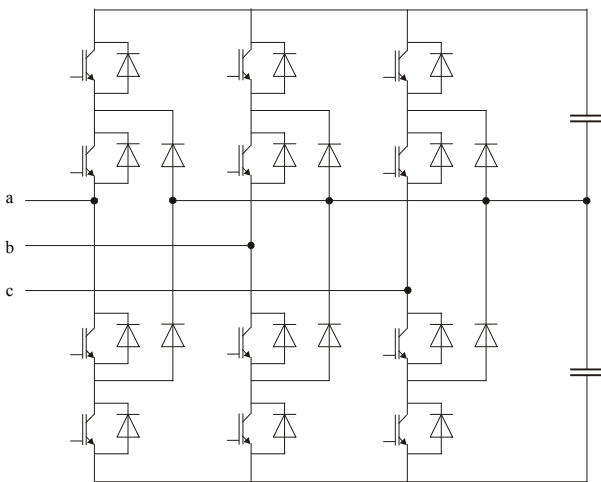

Fig. 15. 3-level VSC configuration.

C. Valve assembly

For SVC Light the IGBT has been chosen as the most appropriate power device. IGBT allows connecting in series, thanks to low delay times for turn-on and turn-off. It has low switching losses and can thus be used at high switching frequencies. Nowadays, devices are available with both high power handling capability and high reliability, making them

suitable for high power converters. Thus, by series connecting IGBTs, VSC ratings of more than 100 MVA are achieved without any need for paralleling devices.

In the converter, there are four IGBT valves and two diode valves in each phase leg. The valves are built up by stacked devices with interposing coolers and an external pressure applied to each stack (Fig. 16).



Fig. 16. SVC Light valve assembly.

VIII. SVC LIGHT WITH ENERGY STORAGE

It is obvious from (2) and (3) that by making the phase shift δ between the VSC voltage U_2 and the grid voltage U_1 non-zero, not only reactive power but also active power can be controlled. The area of operability covers all four quadrants (Fig. 17):

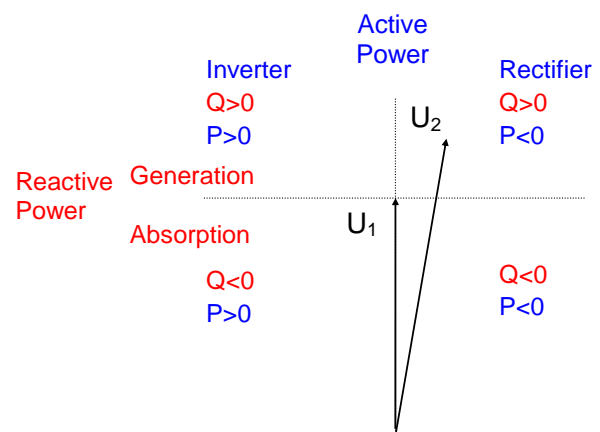

Fig. 17. Four quadrant VSC operating area.

SVC Light with Energy Storage is based on Li-ion batteries. Since SVC Light is designed for high power applications and series connected IGBTs are used to adapt the voltage level, the pole-to-pole voltage is high. Therefore, a number of batteries are connected in series to build up the required voltage level in a battery string. To obtain higher power and energy, a number of parallel battery strings may be added (Fig. 18).

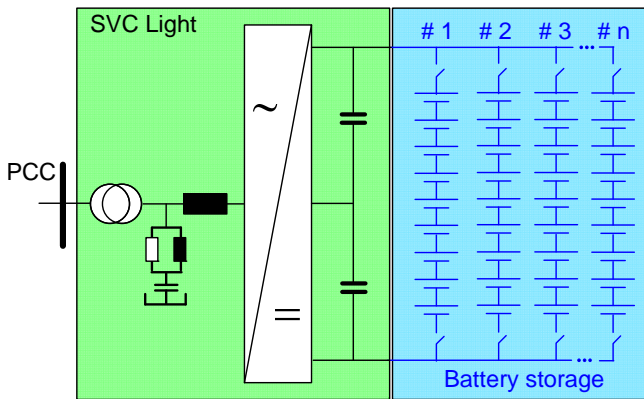

Fig. 18. Basic scheme, SVC Light with Energy Storage.

The battery system comprises rack-mounted Li-ion modules. An array of battery modules will provide the necessary rated DC voltage as well as storage capacity for each given case.

A. Applications

By means of SVC Light with Energy Storage, benefits in conjunction with integrating wind power in grids are enabled:

- Storage of energy during low demand, to be released into the grid during periods of high demand or during periods of more favourable price rates
- Levelling out power fluctuations
- Providing ancillary services such as area frequency control

B. A pilot case

An SVC Light with Energy Storage pilot installation is coming on line in 2010 in an 11 kV distribution grid in the UK (Fig. 19). Its purpose is to test the functionality of the concept in conjunction with a small wind farm and try out various applications such as levelling out short time power fluctuations from the wind farm and storing energy during low demand, to be released into the grid during high demand [6].

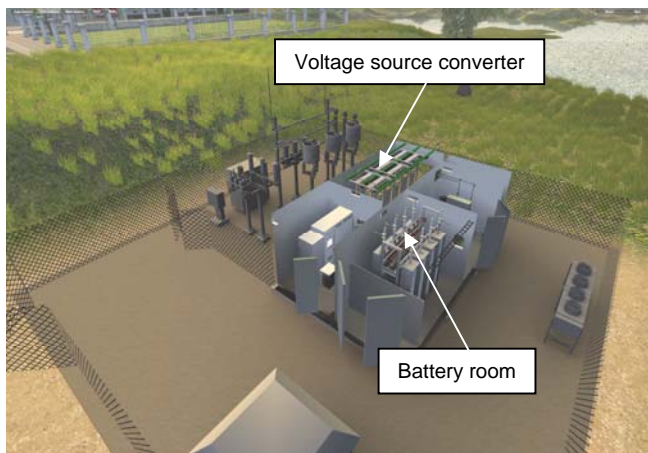

Fig. 19. Artist's view, SVC Light with Energy Storage.

IX. CONCLUSIONS

With integration of large amounts of wind power in power grids, it is usually a demand that the WTG should obey the same rules as other, traditional kinds of generation such as thermal and hydro, i.e. not influence grid stability in any harmful way. That includes “fault ride-through” capability of the WTG in conjunction with faults in the grid. This process can be dynamically supported and improved by means of FACTS devices such as SVC or STATCOM (SVC Light), installed close to the connection point of the wind farm.

The WTG must also be able to provide reactive power at the PCC in accordance with valid grid codes. Here, SVC or SVC Light can yield power factor control, also embracing the reactive power from sea cables in case of off-shore generation.

Also, with SVC or SVC Light at the PCC, dynamic voltage support is yielded for various grid operating conditions.

Series Compensation is another useful FACTS device, enabling stable transmission of large amounts of wind power from the generation site(s) to consumers over long distances.

And last but not least, by connecting battery storage to SVC Light, active power stored can be injected back into the grid when necessary, to support the grid during contingencies, or to help level out active power fluctuations from wind farms.

X. REFERENCES

- [1] R. Grünbaum, M. Noroozian, and B. Thorvaldsson, "FACTS: solutions to power flow control & stability problems," *ABB Review*, vol. 5, 1999.
- [2] E.on Netz, Bayreuth: Grid Code, High and extra high voltage, April 2006.
- [3] A. Boström, R. Grünbaum, M. Halonen, P. Hassink, and M. Thesing, "Voltage stabilization for wind generation integration in Western Texas grid," *Cigré-IEEE Power Engineering Society Conference*, Calgary, 2009.
- [4] R. Grünbaum, J. Samuelsson, "Series capacitors facilitate long distance AC power transmission," *IEEE Power Tech 2005*, St. Petersburg.
- [5] N.G. Hingorani, L. Gyugyi, "Understanding FACTS", The Institute of Electrical and Electronic Engineers, Inc., New York, 2000.
- [6] N. Wade, P. Taylor, P. Lang, J. Svensson, "Energy storage for power flow management and voltage control on an 11 kV UK distribution network," *CIGRE 20th International Conference on Electricity Distribution*, Prague, 8-11 June 2009.

XI. BIOGRAPHY



Rolf Grünbaum (M'2001) was born in Gothenburg, Sweden. He received his M.Sc. in Electrical Engineering from the Chalmers University of Technology, Gothenburg, Sweden.

He is currently working for ABB AB within its FACTS Division, where he is Senior Marketing Manager of FACTS.

Mr. Grünbaum has been active in ABB and previously in Asea for a number of years. Before that, he was employed by DISA Elektronik in Skovlunde, Denmark, where he was involved in marketing of scientific equipment for fluid flow research. He has also held positions as Scientific Counsellor in the Swedish Foreign Service.

Mr. Grünbaum is a member of Cigré and IEEE and the author of a number of papers.