

# SVCs for voltage stabilization in grid with heavy wind power penetration

West Texas has an abundance of wind power. In one hub, located in the McCamey area south of Odessa, wind production has grown to 750 MW and is expected to grow to well over 1 GW in the next few years. In a second hub, located south of Abilene, 1000 MW of wind power is installed.

The transmission system in the McCamey area is basically two 138 kV lines providing parallel paths to deliver the wind power to a 345 kV system supplying the Dallas-Fort Worth area, a major load center. With either of these lines out a substantial increase in reactive losses will occur, leading up to voltage stability problems. Correspondingly, the Abilene hub causes a significant power flow across the 345 kV transmission system towards the Dallas-Fort Worth area. Contingencies in the 345 kV network will load up the underlying 138 kV system, which will have to carry a portion of the power diverted from the 345 kV line lost in the outage.

For these situations, adequate dynamic reactive power support is necessary to maintain system operation at acceptable voltage levels. To improve and maintain voltage stability in the McCamey and Abilene areas, American Electric Power retained ABB to supply and install three SVCs in the system. Each SVC is rated at 40 Mvar inductive to 50 Mvar capacitive (-40/+50 Mvar). Two SVCs, at the Crane and Rio Pecos substations south of Odessa, are connected directly to 69 kV without any need for step-down transformers. The third, located at Bluff Creek close to Abilene, is connected to the 34.5 kV tertiary winding of an existing 345/138 kV autotransformer.

Two more SVCs, with identical ratings, were installed at other AEP locations (Airline and Dilly).

Each installation was initially scheduled to take 11 months from the time of initiation to the end of commissioning, two of the SVCs were completed in just 10 months.

In the planning stage, two possible approaches to fulfill the dynamic var demand were investigated: a number of distributed, small SVCs, or several, medium size SVCs at selected key points. The latter option was chosen, for several reasons:

- Several medium size SVCs cost less than many smaller SVCs;
- They support more and larger mechanically switched shunt capacitors and reactors;
- They lower total service and maintenance requirements.



In addition, the concept of medium size SVC units distributed to critical busses in the system was chosen by AEP for the ability to apply the dynamic support close to load and the wind generators. This yields effective reactive power support during post fault system conditions and maximizes the power transfer capability out of the wind farm areas during shifting wind conditions.

Each SVC also has the ability to control up to five external mechanically switched shunt capacitors and reactors. In addition to enhancing overall dynamic stability, this approach also enables implementation of large-sized shunt elements, as the number of switching operations is minimized. These factors added together created an extremely cost effective Static Var System and also helped improve the project's total cost effectiveness. The single-line diagram below shows the SVCs installed at Crane, Rio Pecos, Dilly, and Airline substations, each rated at 69 kV, -40/+50 Mvar. It comprises a TCR (Thyristor Controlled Reactor) rated at 90 Mvar and three parallel harmonic filters tuned to the 5th, 7th, and 15th harmonics, yielding altogether 50 Mvar at grid frequency (60 cycles).

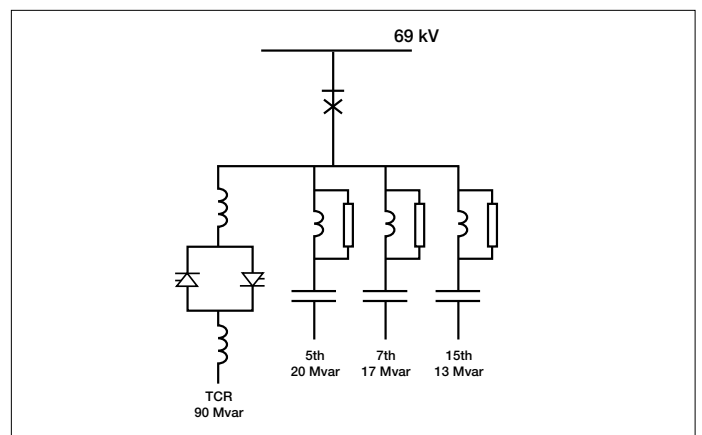

Single-line diagram

### Direct grid connection

A key benefit in the project was that four of the SVCs could be connected to the grid without any need for step-down transformers. This was enabled by an SVC design particularly adapted for direct 69 kV grid connection. This brought a variety of benefits to the project:

- A simplified SVC scheme
- A substantial hardware cost saving
- A saving in transportation costs, weight and volume
- No transformer oil to handle
- No fire hazard due to transformer oil
- No transformer maintenance costs
- Easy expandability since transformer rating and secondary voltage rise is not an issue when adding branches
- No SVC transformer inrush currents and consequential distortion upon energizing or fault clearing, which might be an issue in weak system applications with SVCs including power transformers
- Shorter lead times, not influenced by long transformer delivery times.

And last but not least, the absence of a transformer makes filtering of background harmonics more efficient, as the path from grid to filters gets shorter and easier from an electrical point of view.

### Directly connected thyristor valves

The directly connected thyristor valves employ series connected 4" thyristors, water-cooled, together with associated

grading circuits, thyristor electronics, heat sinks and clamping arrangement. The valves are designed as free standing single assemblies and each valve comprises two series connected standard valve modules per phase (a total of six modules per valve), each with a stack of BCT (Bi-directionally Controlled Thyristors). In the BCT, anti-parallel thyristors have been integrated on a common silicon wafer and therefore, only one thyristor stack is required. With this arrangement, only half the number of thyristor housings and heat sinks is needed. The number of components in a valve and the number of connection points for the water cooling is reduced. This is obviously an improvement from a manufacturing, maintenance and reliability point of view.



TCR valves for 69 kV directly connected SVCs

## Main technical data (Per SVC)

	Crane	Rio Pecos	Dilly	Airline	Bluff Creek
System voltage	69 kV	69 kV	69 kV	69 kV	345/138 kV
Thyristor valve voltage	69 kV (Directly connected)				34.5 kV (Existing trf tertiary)
SVC range	40 Mvar inductive to 50 Mvar capacitive				
Control system	Symmetrical, closed loop three-phase voltage control				
Thyristor valves	BCT, water cooled, indirect light firing				

For more information please contact:

#### ABB AB

#### FACTS

SE-721 64 Västerås, SWEDEN

Phone: +46 (0)21 32 50 00

Fax: +46 (0)21 32 48 10

[www.abb.com](http://www.abb.com)