

## **SVC LIGHT: A POWERFUL TOOL FOR OPTIMIZING SUBTRANSMISSION AND DISTRIBUTION OF POWER.**

R. Grünbaum

ABB Power Systems AB  
SE-721 64 Vasteras, Sweden.  
rolf.grunbaum@se.abb.com

Jacques Pernot

ABB Energie  
92974 Paris La Défense, France  
jacques.pernot@fr.abb.com

### **Abstract**

*Applied to power systems, Voltage Source Converters with ratings far into the tens of MVA range enable effective dynamic as well as steady-state voltage control in subtransmission and distribution of power, as well as control of power quality. This opens up for rational and economical use of new as well as existing power systems, with a minimized need for overhead lines and/or underground cables.*

### **Résumé**

*Les convertisseurs à source de tension ( VSC ) de plusieurs dizaines de MVA, appliqués aux réseaux d'énergie, permettront d'accroître la dynamique et le contrôle en temps réel de la tension des réseaux de distribution et de répartition tout en améliorant la qualité. C'est une ouverture vers l'utilisation plus rationnelle et économique des réseaux d'énergie nouveaux aussi bien qu'existants, comme nous allons le montrer dans cette présentation.*

### **Introduction**

Modern society relies heavily upon electricity. With deregulation and privatization, electricity is becoming a commodity among others. Simultaneously, growing constraints on the building of new lines are appearing as a consequence of increasing focus on environmental aspects as well as of growing scarcity of land available for the purpose. These tendencies in society constitute strong driving forces for more efficient use of existing facilities rather than building of new as the need for power transmission capacity in power systems increases, as well as for making power transmission more cost effective in a deregulated market.

Another current tendency is an increasing highlighting of power quality. Flickering lamps

are no longer accepted in society, nor are deratings or interruptions of industrial processes due to insufficient power quality. Disturbances such as voltage dips and fluctuations, flicker, harmonics and phase unbalance are all annoying as well as detrimental each in their own particular way, and, unless properly remedied, will spread over the grid and become a nuisance to many.

The traditional way to deal with shortcomings in power transmission capacity in grids as well as with poor or insufficient power quality is reinforcing the grid by building of new lines, installing new and bigger transformers, or upgrading of voltages to higher levels. Such measures, however, are expensive and time-consuming, if indeed, as mentioned above, they are permitted at all. From this follows that any alternative enabling increased power transmission capacity, improved power quality and/or improved transmission economy without the need for new overhead lines and/or underground cables will come out very attractive.

### **Efficient grid conditioning**

As a matter of fact, for a power grid, it is not just a question of having enough power transfer capacity. Power transfer must be accompanied by adequate system stability as well as power quality, for the system to perform satisfactorily.

Actually, one can well come up against situations where a need for grid reinforcement is not at all dictated by any need for more power transmission capacity, but by a requirement for increasing of the fault level of the grid. This requirement, in its turn, may be dictated by poor system stability, or insufficient power quality.

In a situation like that, a device particularly conceived for the improvement of system stability and/or power quality, and inserted into the existing network, will prove less costly, less of a burden on the environment, and also ready for use in less time than the building of (a) new subtransmission line(s). VSC technology opens up new interesting avenues in these respects.

### **SVC Light**

SVC Light is a STATCOM type of device [1]. In it, Voltage Source Converter (VSC) and Insulated Gate Bipolar Transistor (IGBT) technologies have been brought together to offer hitherto unseen options for optimizing of power quality and power transfer over existing subtransmission and distribution circuits. In the grid, it is characterized by a small footprint, very high dynamic response, and the ability for active filtering of harmonics and phase unbalance.

This enables high power grid conditioning with high efficiency and high dynamic response, achieving power quality improvement as well as an increase of system stability without any need for grid reinforcing in the more traditional sense. It opens up for increasingly economical utilization of new as well as existing power systems, as more active power can be transmitted under stable system conditions, with higher availability and reliability, and with safekeeping of power quality according to prevailing requirements.

Furthermore, with two devices in a back-to-back configuration, VSC technology offers the ability to control not only reactive power in a grid, but also, when needed, active power transfer. This is further highlighted below.

With SVC Light, the following benefits will be attained in power systems:

#### **Improvement of power quality**

This enables the operation of heavy industry such as steelworks and mines without violation of power quality requirements, without the need of reinforcing the grid just to meet power quality demands and without causing nuisance to other consumers in the grid. Other cases of growing importance are dynamic balancing of

unsymmetrical loads emanating from high speed traction fed from AC grids, and conditioning of infeed of wind power.

#### **Increasing of voltage stability**

This enables a maximizing of system availability as well as of power transmission capability over existing as well as new lines. In other words, more power can be transmitted over existing lines, with a saving of money as well as of environmental impact of the transmission link.

#### **Dynamic balancing of reactive power flow**

This will ensure that the flow of reactive power over circuits will always be at a minimum, thereby maximizing power factor and minimizing system losses attributed to reactive power.

From a practical point of view, the VSC technology brings further benefits such as:

- Reduced area requirements, due to the replacing of passive reactive components by compact electronic converters;
- Modular, factory assembled units, reducing site works and commissioning time and costs;
- Natural relocatability, due to modular, compact design as well as low harmonic interaction with the grid.

#### **Dual applications**

The combination of dual VSCs based on IGBT technology in a back-to-back scheme enables the implementation of asynchronous AC ties in an economical and robust way. Active and reactive power flows are controlled independently of each other, making the scheme perform as an asynchronous power link and a means for dynamic voltage and power quality control on the AC sides of the link at the same time ("dual purpose"). The scheme is virtually independent of the short circuit levels of the surrounding AC grids. Benefits will be increased availability of power at the receiving end, improved power quality and a means for profitable cross-system power trade under open access conditions.

A current example is found in the Eagle Pass cross-border electrical intertie between USA and Mexico [2].

## Voltage Source Converters

The function of a VSC is a fully controllable voltage source matching the system voltage in phase and frequency, and with an amplitude which can be continuously and rapidly controlled, so as to be used as the tool for reactive power control (Fig. 1). In the system, the VSC is connected to the system bus via a small reactor. With the VSC voltage and the bus voltage denoted  $U_2$  and  $U_1$  respectively, it can be shown that the output of the VSC can be expressed as follows:

$$P = \frac{U_1 U_2}{X} \sin \delta \quad (1)$$

$$Q = \frac{U_1 U_2}{X} \cos \delta - \frac{U_1^2}{X} \quad (2)$$

- P: Active power of the VSC
- Q: Reactive power of the VSC
- $U_1$ : Bus voltage
- $U_2$ : VSC voltage
- $\delta$ : Phase difference between the voltages
- X: Reactance of the coupling reactor.

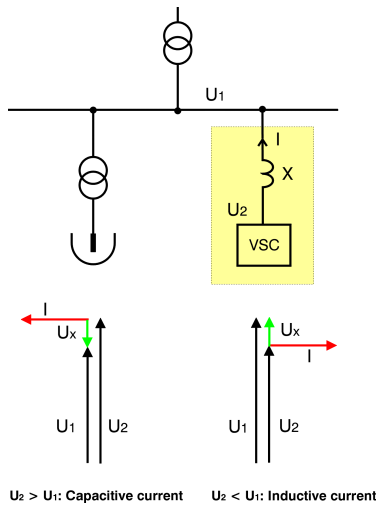

Fig. 1: VSC: a controllable voltage source.

From equations (1) and (2) it can be seen that by choosing zero phaseshift between the bus voltage and the VSC voltage ( $\delta = 0$ ), the VSC will act as a purely reactive element. (In reality, a small phase shift is allowed, in order to make up for the VSC losses.) It is further seen that if  $U_2 > U_1$ , the VSC will act as a generator of reactive power, i.e. it will have a capacitive character. If  $U_2 < U_1$ , the VSC will act as an

absorber of reactive power, i.e. it will have an inductive character.

The reactive power supplied to the network can be controlled very fast. The response time is limited mainly by the switching frequency and the size of the reactor.

## The converter valve

A VSC of three-level configuration is built up as in Fig. 2. One side of the VSC is connected to a capacitor bank, which acts as a DC voltage source. The converter produces a variable AC voltage at its output by connecting the positive pole, the neutral, or the negative pole of the capacitor bank directly to any of the converter outputs.

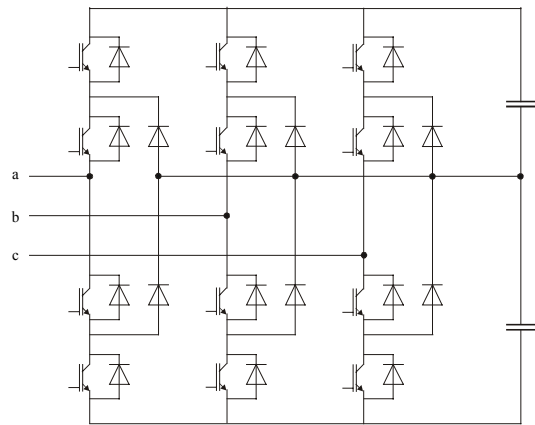

Fig. 2: 3-level VSC configuration.

By use of Pulse Width Modulation (PWM), an AC voltage of nearly sinusoidal shape can be produced without any need for harmonic filtering. This contributes to the compactness of the design, as well as robustness from a harmonic interaction point of view.

**IGBT.** IGBTs of Presspack type are utilized, packaged in housings almost like conventional high power thyristors (Fig. 3). Inside, IGBT chips and antiparallel diode chips are connected in parallel, with pressure contacts normally providing the electrical contact to the outside.

IGBTs allow connecting in series, thanks to low delay times for turn-on and turn-off. This enables the VSC to be directly connected to voltages in the tens of kilovolts range. Thus, by series connection of IGBTs, ratings of tens of

Mvar up to more than 100 Mvar are achieved without any need for paralleling of devices.

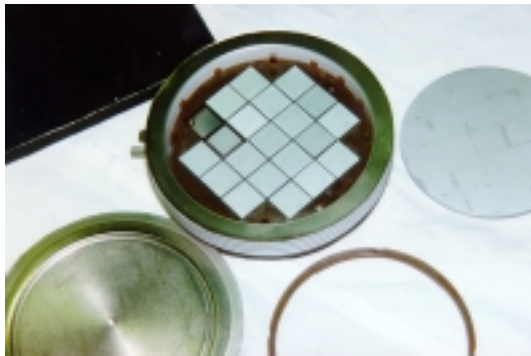

Fig. 3: Presspack IGBT

**Valve assembly.** Water cooling is utilized for the IGBT valves, giving a compact converter design and high current handling capacity (Fig. 4). IGBTs capable of handling close to 2000 A<sub>RMS</sub> are a reality today.



Fig. 4: Converter valve assembly.

**DC capacitors.** The DC capacitors are of a compact, high voltage dry type design, particularly suitable for the application (Fig. 5).



Fig. 5: Dry type, high voltage DC capacitors.

By use of metallized film, insulated by means of polymers instead of impregnated materials, the capacitor gets a dry design, making it environmentally very friendly. In manufacturing, it requires neither impregnating fluids nor the use of paint solubles. It has high energy density, which together with its cylindrical shape enables very compact build-up of capacitor banks utilized in the VSC scheme.

### A recent application

An SVC Light rated at 0-44 Mvar has been in operation for some time at Uddeholm Tooling in Sweden for the purpose of improving of power quality in the surrounding grid without having to reinforce the grid in a more traditional sense. The steel mill operates an electric arc furnace (EAF) rated at 31,5 / 37,8 MVA as well as a ladle furnace rated at 6 / 7,7 MVA. The point of common connection is at 132 kV, with a fault level which in the most unfavourable case does not exceed 1000 MVA.

Without any specific measures taken, there would be considerable amounts of flicker emanating from the mill. This was not considered as any serious impediment at the time when the mill was started, but today, requirements on human environment has made the situation more demanding.

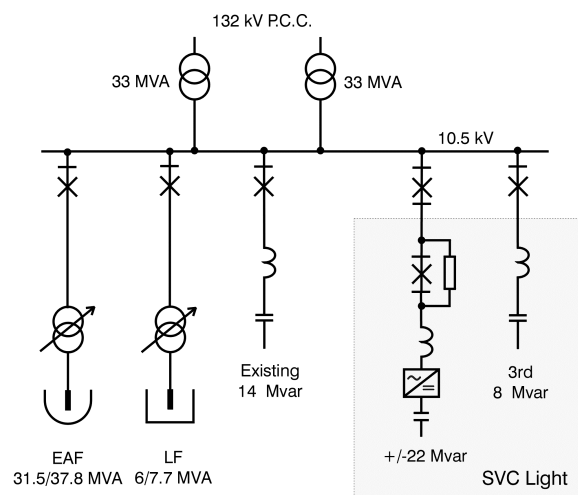

Fig. 6: Single-line diagram, Uddeholm Tooling

The installation comprises a 22 MVA VSC connected to the 10,5 kV EAF bus via air core phase reactors, one in each phase (Fig. 6). Furthermore, an 8 Mvar harmonic filter is

included, which together with a 14 Mvar filter already existing in the plant provides offsetting of the dynamic range of the VSC from  $-/+ 22$  Mvar to the required 0-44 Mvar.

### VSC control

To mitigate flicker efficiently, the utilized control algorithm calculates setpoints for the current to be produced. In this process, the EAF current as well as the bus voltage are used. To fast control the VSC instantaneous current, a concept with voltage-time area across the coupling reactor is used. This means that by controlling the time a certain voltage is applied across the reactor, the desired current through the reactor can be obtained.

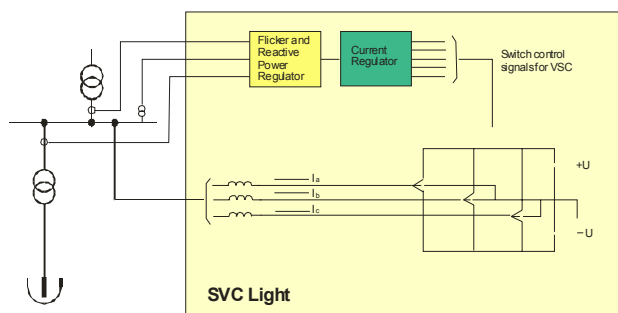

Fig. 7: VSC control principle.

The reactor voltage consists of the difference between the bus voltage and the voltage produced by the VSC. Now, what can be controlled to influence the current is the voltage produced by the VSC. By employing PWM, the desired current is obtained fast by applying the proper VSC voltage (Fig. 7).

### Flicker mitigation

Flicker is expressed by means of the Flicker Severity Level  $P_{st}$  which directly expresses the degree of irritation with  $P_{st} = 1$  meaning the limit of disturbance.

The flicker threshold curve according to IEC (Fig. 8) shows maximum permitted voltage fluctuations as a function of frequency inside the flicker spectrum for the borderline case of  $P_{st} = 1$ . The most critical part of the spectrum falls around 8 Hz, which is where the human eye is at its most sensitive to light fluctuations.

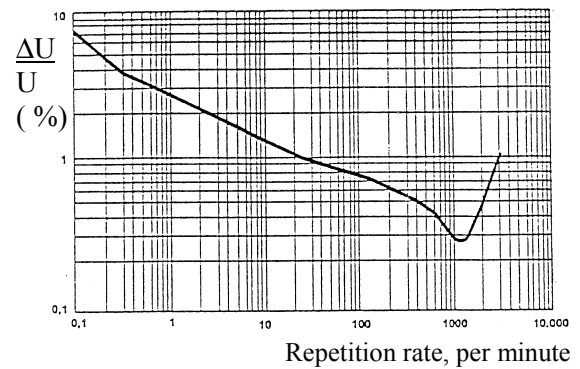

Fig. 8: Flicker threshold curve.

The basic standard to be used for flicker measurement is IEC 1000-4-15. The measuring device (flicker meter) gives results on each successive 10 minutes interval ( $P_{st}$  values), as well as on 2 hours intervals ( $P_{1t}$ ). According to the UIE works, a  $P_{st}$  limit may be occasionally exceeded, provided that the corresponding part of the observation period is sufficiently small (typically no more than 1%). The corresponding  $P_{st}(99\%)$  can then be used as a correct value [3].

Field measurements of flicker mitigation at the point of common coupling have been performed. The graph shows the outcome of these measurements (Fig. 9). Statistical evaluation gives as result a flicker severity factor without flicker compensation equal to  $P_{stA}(95\%) = 3,73$ , and a flicker severity factor with flicker compensation equal to  $P_{stB}(95\%) = 0,64$ . Hence, the following flicker mitigation factor is reached:

$$R_{SVC\text{Light}} = \frac{P_{stA}}{P_{stB}} = 5,8 \quad (3)$$

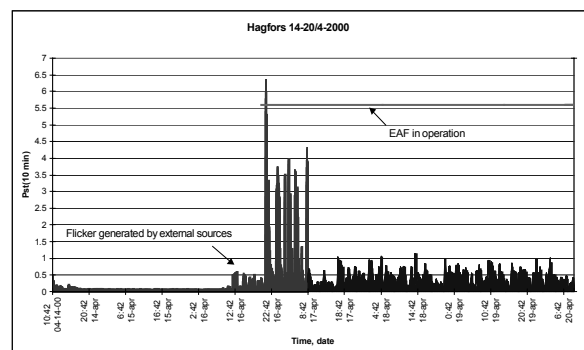

Fig. 9: Impact of flicker compensation.

### Active filtering

The fast response of the VSC scheme enables its use as an active filter.

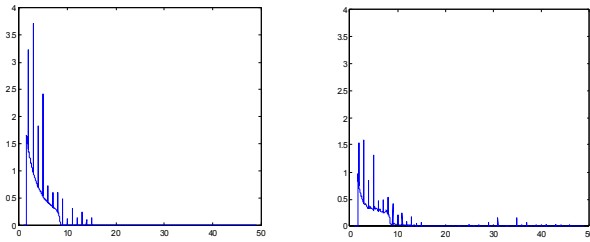

Fig. 10: Active filtering of EAF harmonics.

Fig. 10 shows harmonic spectra at the plant, without as well as with the device in operation. What is seen is filtering of the harmonic spectrum of the EAF all the way up to the 14<sup>th</sup> harmonic, which is the highest harmonic of any significance appearing from the EAF. The VSC scheme itself has practically no harmonic generation below the 33rd harmonic.

### Plant layout

All SVC Light equipment except the phase reactors and the 8 Mvar harmonic filter is housed indoors in a small prefabricated building. The phase reactors and filter have been erected in a small, fenced outdoor yard. All in all, this gives a very compact layout of the installation, Fig. 11.



Fig. 11: The Uddeholm Tooling SVC Light.

### Conclusion

Voltage source converters far into the tens of MVA range and based on IGBT technology are now a reality. This opens up for improving of dynamic stability as well as power quality in power distribution in a quicker, more cost effective as well as environmentally more friendly way than by having to build additional overhead lines and/or underground cables. Flicker mitigation as well as active harmonic filtering are readily attainable by means of pulse width modulation in the kHz range.

Furthermore, VSCs in a back-to-back scheme offer means for stable interconnection of weak AC systems where active power flow and system voltages can be controlled independently of each other.

### References

- [1] B. Bijlenga et al, SVC Light-a powerful tool for power quality improvement, ABB Review No. 6, 1998.
- [2] A. Edris et al, Emerging Application of Voltage Source Converter Technology in Back-to-Back Asynchronous Tie, VII SEPOPE, 2000.
- [3]. G. Borloo et al, Practical implementation of IEC publications 61000-3-6 and 61000-3-7. Experiences in Belgium, 8<sup>th</sup> Internat PQ Appl Conf, Cape Town, South Africa, 1998.

SEE\_FILE2001