

# SVC for power quality control of a very large EAF in Turkey



ABB has installed a Static Var Compensator (SVC) rated at 0-330 Mvar in a green-field steel plant in the Iskenderun area in Turkey, owned and operated by MMK. The steel plant has a production capacity of 2.5 million tons of flat-rolled products and 1.2 million tons of cold rolled products annually. The purpose of the SVC is reduction of network disturbances emanating from the operation of a very large electric arc furnace (EAF) and a ladle furnace (LF), as well as power factor correction. The SVC was supplied under a turn-key contract together with 380/34.5 kV main power transformers as well as 380 kV and 34.5 switchgear. The SVC was commissioned in 2011.

The EAF, rated at 300 MVA, is among the largest ever installed in a steel plant in the world. The size of the SVC is directly correlated to the size of the EAF, and the SVC is among the largest of its kind for this purpose, as well.

The EAF has strong and stochastically fluctuating reactive power consumption, which, unless remedied, will lead to voltage fluctuations and flicker. Furthermore, the EAF acts as an unbalanced load, creating negative-phase sequence components in currents and voltages, which have a detrimental impact on other installations connected to the same grid. Also, due to a low power factor of the EAF, the system losses are high, which is costly as well as unfavourable from the point of view of electric energy consumption per unit steel. And finally, the EAF is a strong source of harmonics. SVC is an efficient

means of mitigating these shortcomings to power quality in the plant as well as in the feeding grid. As additional benefits, productivity and process economy can be improved.

## Main circuit design

The SVC comprises a Thyristor-Controlled Reactor (TCR) rated at 330 Mvar, as well as 2nd, 3rd, 4th, 5th and 6th Harmonic Filters, altogether also rated at 330 Mvar. All in all, the reactive power control range of the SVC yields 0-330 Mvar (capacitive), continuously variable.

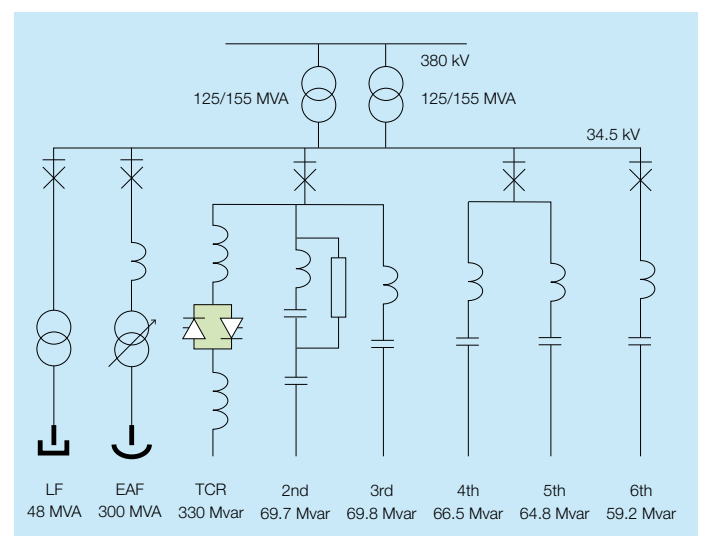

Single-line diagram of the SVC and furnaces.

The TCR is of a record size for the application, with its total rating confined to one single branch. By phase angle control of the TCR, the RMS value of the current through the reactor is continuously controllable. Together with the capacitive reactance provided by the harmonic filters at 50 Hz, the total dynamic range of the SVC is made capacitive. Harmonics generated by thyristor control of the reactor current are absorbed in the harmonic filters.

### Thyristor valve

The thyristor valve employs series connected high power thyristors, water-cooled, together with associated snubber circuits, thyristor electronics, heat sinks and clamping arrangements. The valve is designed with free standing single-phase assemblies, each phase with two stacks of thyristors, one stack for each current direction. The thyristors are electrically fired and the energy for firing is taken from the snubber capacitors. Firing orders are communicated via optical light guides from the valve control unit. This type of system is usually called "indirect light firing".

### Harmonic filter design

By introducing damping in the 2nd harmonic filter, possible problems with inter-harmonics and parallel resonances with the grid can be mastered. The fundamental current is bypassed the resistor, and substantial resistive losses are avoided. The 3rd, 4th, 5th and 6th harmonic filters are designed as band-pass filters and consist of a reactor and a capacitor in series to attain the required tuning.

### Control system

The control system is based on the ABB MACH 2 concept, which is a system of both hardware and software, specifically developed for power applications. MACH 2 is built around an industrial PC with add-in boards and I/O racks connected through standard type field busses like CAN and TDM. The aim of the SVC is to control the power factor on the incoming line, stabilise the voltage at the furnace bus, and reduce the flicker at the Point of Common Connection (PCC). The automatic control system consists of an open loop phase-wise susceptance regulator and a closed loop three-phase susceptance regulator. All regulators are located in the MACH 2 computer.

The main objective of the open loop regulator is to generate fast susceptance references for the SVC in order to suppress flicker and phase unbalances. The SVC compensates for the EAF currents consisting of the reactive part of the positive phase sequence current, and both the active and reactive part of the negative phase sequence current. Hence, the voltage drop and fluctuations over the AC network are minimized.

For more information please contact:

### ABB AB FACTS

SE-721 64 Västerås, SWEDEN  
Phone: +46 (0)21 32 50 00  
Fax: +46 (0)21 32 48 10

[www.abb.com/FACTS](http://www.abb.com/FACTS)

As for the closed loop control, two different control strategies can be used:

- Reactive power control
- Power factor control.

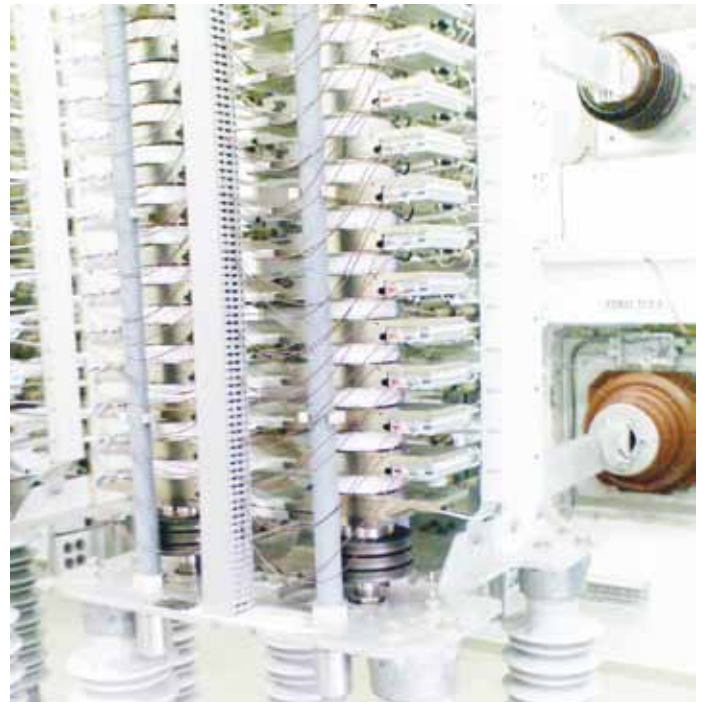

Thyristor valve: one phase stack

### Performance

The following contractual versus measured performance values are valid at the 380 kV PCC. As can be seen, the SVC more than fulfils the contractual requirements in all respects.

Performance parameters	Contractual values	Measured values
Power factor	≥ 0.95	1.00
Flicker, Pst (95%)	≤ 0.85	0.70
Total Voltage Distortion, THD (95%)	< 2%	0.86%

### Main technical data

Bus voltage	34.5 kV
SVC rating	0-330 Mvar capacitive
TCR	330 Mvar, in one single branch
Harmonic filters	2nd harmonic / 69.7 Mvar 3rd harmonic / 69.8 Mvar 4th harmonic / 66.5 Mvar 5th harmonic / 64.8 Mvar 6th harmonic / 59.2 Mvar
Control scheme	Phasewise, open loop susceptance regulator, plus a three phase closed loop susceptance regulator
Thyristor valve	PCT equipped, water cooled, with indirect light firing.