

SVC for voltage stabilization and harmonic suppression in a ladle furnace and rolling mill

Since 1984, DOFASCO inc, Hamilton, Ontario have operated a Static Var Compensator (SVC) delivered by ABB in their No. 2 Hot Strip Mill. The rated load of the Hot Strip Mill thyristor converters is approximately 50 MW (70.000 hp). The SVC which has a dynamic range of 60 Mvar is connected to the 14.1 kV Finishing Mill bus.

Its purpose is to stabilize the bus voltage under the varying load conditions which occur during the running of the mill. It furthermore comprises harmonic filters tuned to the 5 th, 7 th and 11 th harmonics in order to suppress harmonics generated by the thyristor converters in the rolling mill, thereby preventing these harmonics from entering into the surrounding parts of the network.

It also achieves power factor correction of the rolling mill, thereby relieving the network of reactive power burden and contributing to a decrease of the running costs of the mill.

Besides being a source of harmonics, a rolling mill as a load on the network is generally characterized by high and fluctuating consumption of reactive as well as active power. As a consequence, the rolling mill will give rise to voltage fluctuations on the feeding network, the severity of which being dependent on the relationship between the size of the rolling mill and the strength of the network. At the same time, for safe operation, the thyristor converters which form part of the rolling mill can only tolerate limited fluctuations in the supply voltage. Consequently, the voltage fluctuations, if severe enough, may endanger the reliable operation of the rolling mill, as well as cause nuisance to other equipment connected to the same network.

In the present case it was decided to invest in the SVC in order to attain dynamic bus voltage stabilization and harmonic suppression, thereby improving the performance of the Hot Strip Mill itself and at the same time fulfil existing obligations towards neighbouring consumers by keeping the quality of the voltage at the point of common coupling (230 kV) within specified limits.

The maximizing of useful active power transfer while minimizing system losses was also seen as a valuable feature.

Synchronous condensers were considered but were rejected as being an inferior solution compared to SVC, among others due to higher cost and slower control response.

The SVC ensures the following specified criteria for voltage control

Maximum 14.1 kV bus voltage variation with the SVC in operation

- Steady-state -2% to +1%
- Transient (2 Hz max.) -4% to +2%

Extension of the SVC

Based on the positive experiences gained from more than two years of operation of the SVC together with the rolling mill, an additional order was awarded to ABB in 1986 for an extension of the SVC by 30 Mvar, making a total dynamic (thyristor-controlled) range of 90 Mvar. The installation was made in conjunction with an extension of the Finishing Mill.

The SVC extension secures continued improvement of the overall system conditions during operation of the rolling mill.

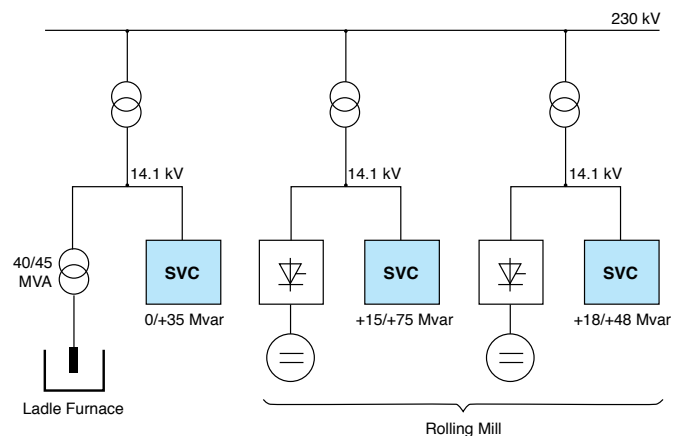

SVC for ladle furnace

Another SVC rated at 0-35 Mvar at 14.1 kV also supplied by ABB is in operation since 1987 at DOFASCO. The purpose of this SVC is to stabilize the feeding voltage and provide dynamic power factor correction of a ladle furnace rated at 40/45 MVA.

The SVC ensures that the furnace bus voltage is kept within specified limits for all possible operating conditions of the furnace:

Maximum 14.1 kV bus voltage variation with the SVC in operation

- Steady-state -2% to +1%
- Transient (2 cycles max) -4% to +2%

The power factor of the ladle furnace can vary between 0.60 and 0.80. The SVC corrects it to 0.95 for all operating conditions of the furnace.

For more information please contact:

ABB AB FACTS

SE-721 64 Västerås, Sweden

Phone: +46 21 32 50 00

Fax: +46 21 32 48 10

www.abb.com/FACTS

Technical data SVC for rolling mill	Phase 1	Extension
Controlled voltage	14.1 kV	14.1 kV
Overall rating	75 Mvar	48 Mvar
Dynamic range	60 Mvar	30 Mvar
Harmonic filtering	4.5 Mvar/5th	8 Mvar/5th
	2.5 Mvar/7th	2.5 Mvar/7th
	8 Mvar/11th	8 Mvar/11th
Control system	3-phase symmetrical open-loop reactive power control	

Technical data SVC for ladle furnace	
Controlled voltage	14.1 kV
Dynamic range	35 Mvar
Harmonic filtering	25 Mvar/3rd
	10 Mvar/5th
Control system	Phase-wise, open loop reactive power control plus 3-phase symmetrical closed loop reactive power control

Single-line diagram, SVC for ladle furnace

