

CEPSI 2006

16<sup>th</sup> Conference of the Electric Power Supply Industry, Mumbai, India

6-10 November 2006.

## **CITY INFEED WITH HVDC LIGHT® AND EXTRUDED CABLES**

by

**Björn Jacobson\***     **Paulo Fischer de Toledo**     **Gunnar Asplund**

*ABB Power Technologies AB,  
Power Systems – HVDC, Ludvika, Sweden*

**Marc Jeroense**

*ABB Power Technologies AB,  
High Voltage Cables, Karlskrona, Sweden*

### ABSTRACT

Urban electrical power systems with steep demand increase need easily located solutions with short lead time from decision to transmission. While AC cable solutions can offer sufficient power ratings, the problems of load controllability and short circuit power increase with every added circuit. These problems may be countered with Voltage Source Converter (VSC) based technology using DC-cables for transmission, such as HVDC Light®. This technology offers up to 500 MW per station with small footprint, ideal for infeed to city centers. Fast implementation is possible thanks to modular pre-assembled design and extruded polymer underground cables. System benefits from the VSC technology, such as independent full active and reactive power control and no added short circuit power makes it easy to apply in a heavily loaded grid. From an environmental point of view, the dc-cable technology gives virtually no alternating magnetic field and no risk for oil leakage. Higher transmission capacity is possible through polymer DC-cables as compared to equivalent AC-cables. A number of different topologies are possible for single or multi-infeed, giving large freedom of design to adapt to each specific network situation.

### **1. INTRODUCTION**

In this age of accelerating urbanisation, the challenge of generating, transmitting and distributing the rapidly increasing amounts of electrical energy in demand is enormous. This paper addresses the specific problem of supplying electricity to the urban areas. The development of urban networks stands to address the issues of congestion, pollution, acoustical and electrical noise, short-circuit power restriction, permits and scarcity of land area for siting among others.

When more AC-circuits are added to a city center network, the short circuit power increases, especially if AC-cables are added, due to their low reactance per meter. In extreme cases, this may lead to an upgrading need on several substations to cope with the new network situation.

The development in the past ten years of compact converters and extruded cable systems for Voltage Source Converter (VSC) based HVDC [1] has given the grid designer an extended palette of possibilities to solve the problems with city center infeed, compared to solely AC alternatives. Since the inauguration of the first installation of a VSC based HVDC system March 1997 in Hellsjön-Grängesberg, Sweden, the available power rating and the power density of the system has steadily increased thanks to incremental developments in cable system, control system and in IGBT valves, making VSC based HVDC a realistic alternative today.

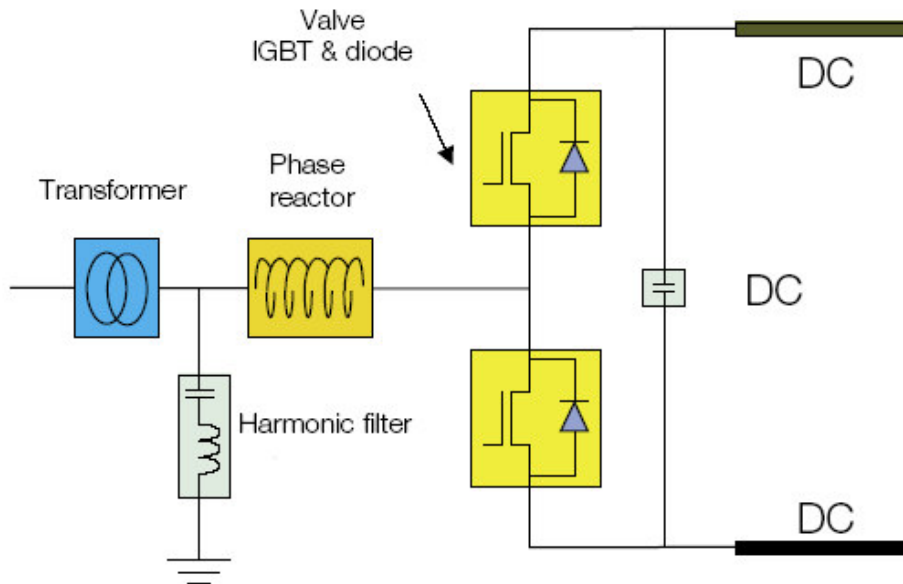

Figure 1: Simplified circuit diagram of one phase of a two-level Voltage Source Converter. The DC-capacitor is common for all three phases. The valves consist of several series connected Press Pack IGBT's.

Lead time for delivery is improving; the Cross Sound Cable system was delivered to the customer 24 months after order, 2002. The EstLink project will be handed over 19 months after signing of the contract, meaning end of 2006.

The converter valves, control system and cooling system are built in pre-assembled modules, reducing the assembly time on site to a minimum. The laying procedure and jointing of extruded dc-transmission cables is very fast compared to oil-impregnated cables.

## 2. POWER HANDLING

The largest VSC based HVDC system so far built is Cross Sound Cable, located close to New York City in the sound between Long Island and New Haven, Connecticut in the United States [2]. The power rating is 330 MW at a nominal dc link voltage of  $\pm 150$  kV. The dc-current is maximum 1175 A.

The recent development of presspack IGBT's capable of handling up to 1780 Arms at the phase terminal [3] of the converter and capable of continuously switching at peak currents up to 4000 A at the thermal limit gives an opportunity to expand the power rating of the station by current increase, while retaining the same voltage class of the converter valves and other equipment. The area requirement of the station is not affected, consequently the power density of the HVDC converter station is increased by 50% or more. System power transmission capability, receiving end, may be between 525 - 555 MW depending on cable length and possible thermal restrictions. If more power is needed, more circuits may be added in parallel. Some of the apparent power handling may be reserved for voltage support/reactive power balancing since the VSC system can be used as a combined Statcom and HVDC.

The reactive and active power may be controlled independently, as long as the total power vector is within the envelope of the allowable apparent power. The controllability of the HVDC link may be used to control the power flow in the AC network, thus optimizing the load flow through the existing lines. This could be used to reduce losses, to increase the capacity and to improve stability [4], [9].

## 3. FOOT-PRINT OF CONVERTER STATION

To reduce the visual impact and to reduce the insulation requirements on the equipment, the station is built as an enclosed building containing all equipment except power transformer and cooling fans.

To minimize the foot-print and the total volume, the converter may be built in two or more floors.

This design principle gives a station design suitable for high power handling on a compact site that would be useful where land area is at a premium.

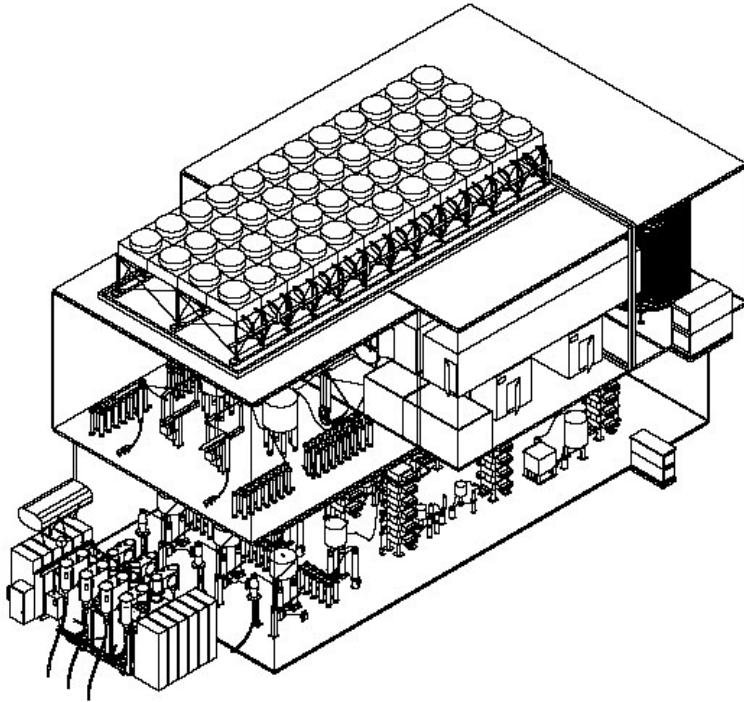

Figure 2. Possible layout of compact VSC station for 500 MW. Dimensions in this configuration are 48 x 25 x 27 m (L x W x H). Ground floor: Transformer and AC-side filters. First floor: Phase reactors, converter valves, control and cooling equipment, DC-side filters and cable terminations. Second floor: Cooling fans, which may be omitted if a nearby river or other water is available for cooling.

#### 4. UNDERGROUNDING AND RIGHT-OF-WAY

Entering an urban or sub-urban area with a new high-voltage overhead line may in some cases be very difficult or even impossible due to scarcity of available land. Then some of the alternatives may be increased generation capacity in the city, installing AC-cables or installing DC-cables. Both the alternatives with AC and DC cables can be motivated and are technically feasible. In the case that the DC alternative is chosen for reasons of system benefits, it is most suitable to make use of polymer DC cables, as for example the HVDC-Light® cable system, instead of their paper/oil insulated counterparts. Installation of polymer HVDC cable systems is easier for city infeed purposes due to the flexibility and robustness of the cables and the quick installation of joints [10]. Jointing polymer HVDC cables takes considerably less time than jointing paper/oil insulated ones.

HVDC cables generate a static magnetic field, just as our own mother earth. The magnitude of the magnetic field generated by a pair of HVDC cables in typical installation conditions is far lower than the earth magnetic field we all are exposed to. Therefore, no harmful effects worse than those induced by our own earth are induced by the cable system. A typical graph is shown in Figure 3, where the earth magnetic field is compared with the field of a pair of DC cables 1 meter below ground surface.

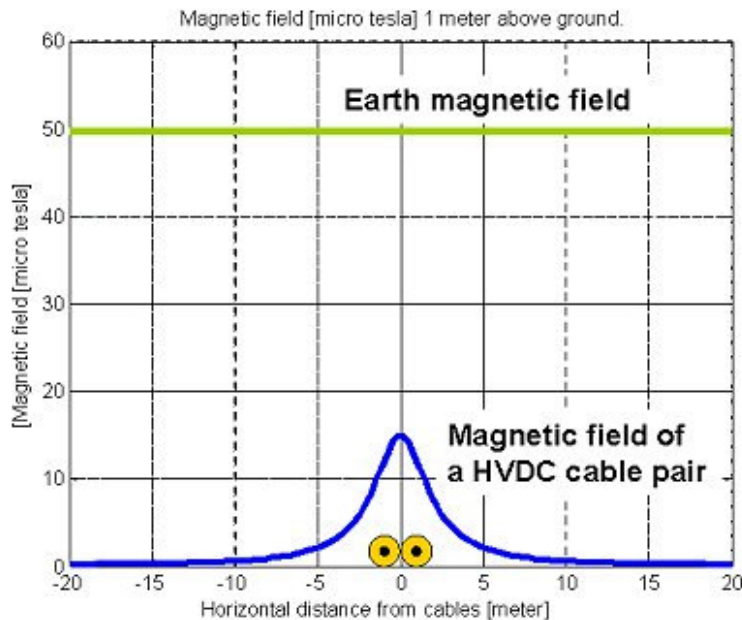

Figure 3. The static magnetic field of a pair of HVDC cables (300 MW) buried 1 meter below the surface and calculated at a level of 1 meter above the surface. In addition the earth magnetic field is shown.

AC-cables generally solve the problem of right-of-way but may be difficult to implement due to reactive power balancing problems, added short circuit power and in some cases limited transmission distance [4]. An AC-cable network has a large generation of reactive power during low-load, forcing measures such as shunt reactors to be implemented.

The DC cable alternative gives no technical limit to the transmission distance, adds no short circuit power and actually enables improved reactive power balance due to the properties of the converters. The power handling of a given cable dimension is higher for DC than for AC due to better utilization of the insulation and lower losses in conductor and shield.



Figure 4. Pair of extruded land DC cables showing from center outward: aluminum conductor, conducting XLPE- layer, dc-insulation XLPE, ground side conductive XLPE, copper shield wires, aluminum outer wrapping and outer sealing and mechanical protection..

Today, cables for VSC based HVDC are manufactured with extruded plastic insulation, meaning that they are oil-free by design. The extruded cables are more flexible than their oil-impregnated counterparts and they are much more easily jointed using pre-fabricated joints.

Extruded cables may be plowed down into the ground by a fast semi-automatic process if the soil is suitable. The use of water ways, road banks, railroad track banks and OH-line ways are some possible alternatives for the cable route. When crossing roads, the cables may be passed through by using directional drilling. Replacing existing OH-lines with DC-cables is an opportunity to make valuable land available for other uses.



Figure 5: Example of cable laying in a corridor already used by OH-lines. AC PEX-cable in Qatar.

**5. TOPOLOGIES AND EXPANSION**

The basic VSC HVDC topology is simply a converter at each end of a pair of extruded DC-transmission cables. The station feeding energy into the dc-circuit is called the rectifier, the converter taking energy from the dc-circuit and feeding it into the receiving AC-network is called the inverter. In VSC, the roles of inverter and rectifier can be interchanged between the stations at any time without delay, without breaker switching and without polarity reversal. Both stations can independently generate or consume reactive power as suitable at the connection point.

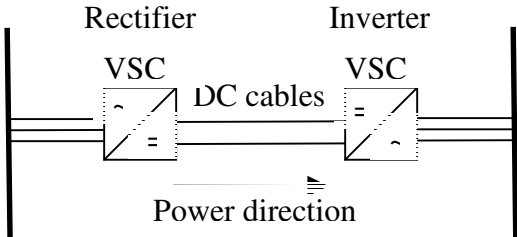

Figure 6: Basic topology of a VSC HVDC transmission with cables.

The VSC technology gives entirely new possibilities to enhance the city grid. Some examples are given in [4]. City areas have high load densities and in general the quality and security of supply are very important. Due to the difficulty of obtaining land, especially in those cases where the site is some distance from the existing high voltage network, the VSC HVDC transmission system is attractive. An example of a radial system is shown in Figure 7-a, while in Figure 7-b is shown another example of a meshed-type where improved reliability is required.

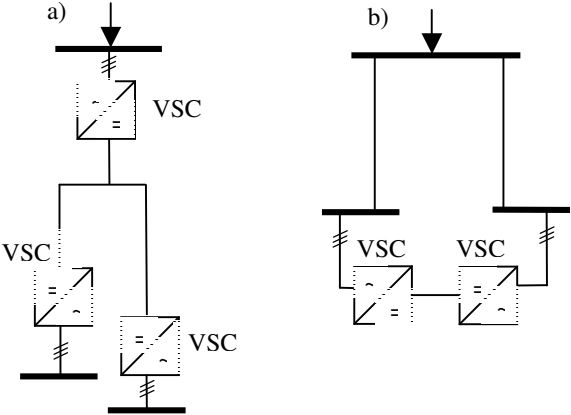

Figure 7. Examples of topologies for City Infeed using VSC based HVDC. Example b) gives increased overall reliability of supply. In both a) and b) the VSC will give increased voltage performance with reactive power control in the HVDC converters. Alternative b) is topologically equivalent to closing an open loop circuit, which with HVDC gives an extended system without increasing the short circuit power.

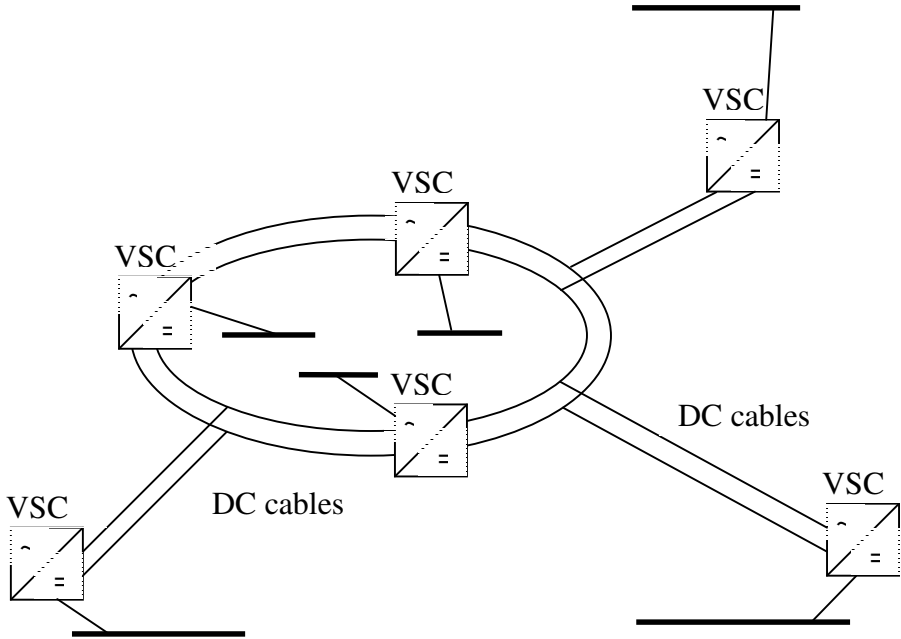

Figure 8: Vision of a modern multi-terminal HVDC network with VSC converters and extruded cables. This could be a new system or an expansion of an existing city network. In this example power is fed from the transmission grid and distributed through a dc-cable ring to inverter stations.

The VSC technology facilitates the connection of several converters to a common bipolar dc-bus, which means that the VSC converters may be arranged as a multi-terminal HVDC-system [4 and 7]. This is easier with VSC as compared to Current Source Converters, since the voltage polarity is not reversed when reversing the power direction. A multi-terminal HVDC cable grid could be used to improve or partly replace an existing network or be used when large scale expansions of a city is foreseen. A futuristic arrangement with multiple incoming from

the transmission lines is shown in Figure 8. This scheme can be characterized by its high power density of supply and high reliability if designed to meet the peak load with any feeder out of service. It should be noted that having the VSC converters the possibility to control the power flow, from this arrangement it is also possible to obtain a suitable composition of power from different supplier feeder.

The installation cost of a cable can be a significant part of the total cable system cost or even dominate it [4]. Thus it may be suitable for a planned expansion to install cables of the final current rating at once but to install just the amount of converters necessary at each given instant.

## 6. REACTIVE POWER SUPPORT

The consumption of reactive power at the city center varies during the day. The resulting voltage fluctuations may be counteracted by using switched capacitor banks and shunt reactors or by using Static VAR Compensators. Switched passive components can however not handle dynamic phenomena from period to period, like faults and transients in the system.

An innovative approach was taken by Austin Energy in Texas, U.S., by installing a VSC based Statcom in place of an obsolete oil/gas-fuelled power plant in the city center of Austin. In this case, the dynamic reactive power support was taken over by the Statcom and the active power was taken from outside circuits. [5]



*Figure 9. VSC based Statcom in Austin City Center.*

HVDC with VSC converters have the dual function of controllable active and reactive power injection or consumption as needed. The system can be regulated quickly and respond to transients and other sudden changes in the network conditions [6].

The dynamic abilities of VSC based HVDC may be very useful in stabilizing the network, reducing the probability of a black-out and in the case of a network breakdown, to speed up the re-construction of the network.

## 7. CONCLUSIONS

Voltage source converter based technology using DC-cables for transmission, such as HVDC Light®, offers up to 500 MW per station with small footprint, ideal for infeed to city centers. Fast implementation is possible thanks to modular pre-assembled design and extruded polymer underground cables. System benefits from the VSC technology, such as independent full active and reactive power control and no added short circuit power makes it easy to apply in a heavily loaded grid. The use of VSC-HVDC transmission enables long cable distances, higher transmission capability through the polymer cables as compared to equivalent AC-cables and the possibility to remove obsolete and polluting generating plants from the city center. Step-wise expansion can be built in small or large increments. A number of different topologies are possible for single or multi-infeed, giving large freedom of design to adapt to each specific network situation.

## 8. REFERENCES

References may be located at Internet: <http://www.abb.com/hvdc>, Except [3], [4], [5] and [8].

- [1] G. Asplund, K. Eriksson, K. Svensson, "DC Transmission based on Voltage Source Converters", Cigré SC14 Colloquium in South Africa, 1997.
- [2] L. Ronström, B. D. Railing, J. J. Miller, P. Steckley, G. Moreau, P. Bard, J. Lindberg, "Cross Sound Cable Project Second Generation VSC Technology for HVDC", Cigré Session 2004, B4-102.
- [3] ABB Semiconductors component 5SNX20H2500, data sheet 5SYB 0116-03, June 2004., Internet [http://library.abb.com/GLOBAL/SCOT/scot256.nsf/VerityDisplay/8BF9BE3AB334D422C1256F90004CA677/\\$File/5SNX%2020H2500\\_5SYB%200116-03June%2004.pdf](http://library.abb.com/GLOBAL/SCOT/scot256.nsf/VerityDisplay/8BF9BE3AB334D422C1256F90004CA677/$File/5SNX%2020H2500_5SYB%200116-03June%2004.pdf)
- [4] P. Fischer de Toledo, "Feasibility of HVDC for City Infeed", Licentiate Thesis, Royal Institute of Technology, Stockholm 2003.
- [5] E. M. John, A. Oskoui, Å. Petersson "Using a STATCOM to retire urban generation"; Power Systems Conference and Exposition, 2004. IEEE PES, 10-13 Oct. 2004 Page(s):693 - 698 vol.2.
- [6] T. Larsson, Å. Petersson, A. Edris, D. Kidd, R. Haley, F. Aboytes, "Eagle Pass Back-to-Back Tie: a Dual Purpose Application of Voltage Source Converter Technology", Internet [http://library.abb.com/GLOBAL/SCOT/scot221.nsf/VerityDisplay/4F9E1DA87EC65947C1256FDA003B4CF0/\\$File/IEEE%20SM%2001%20Paper1.pdf](http://library.abb.com/GLOBAL/SCOT/scot221.nsf/VerityDisplay/4F9E1DA87EC65947C1256FDA003B4CF0/$File/IEEE%20SM%2001%20Paper1.pdf)
- [7] L. Stenius, K. Eriksson, "HVDC Light – An excellent tool for City Center Infeed", PowerGen Conference, Singapore, September 1999.
- [8] B. Normark, D. Ravemark, "Underground transmission with HVDC Light", ABB Review, 2005.
- [9] S. G. Johansson, G. Asplund, E. Jansson, R. Rudervall, "Power System Stability Benefits with VSC DC-Transmission Systems", Cigré B4-204, Session 2004.
- [10] HVDC Light – Submarine and land power cables. Internet, [www.abb.com/cables](http://www.abb.com/cables).

## 9. AUTHORS



**Björn Jacobson** was born in Uppsala, Sweden, on September 13, 1964. He got his M.Sc. in Engineering Physics from the University of Uppsala in 1988. From 1988 to 1997 he worked for ABB Components in Ludvika, with development and insulation design of high voltage bushings. In 1997 he joined the HVDC division of ABB in Ludvika to work with development of Voltage Source Converter valves for among others Hagfors SVC Light, Gotland HVDC Light and Cross Sound Cable. 2002-2004 he headed the mechanical design departments for valves and plant design. December 2004 he became project manager for development of the next generation of HVDC Light systems.



**Gunnar Asplund** was born in Stockholm, Sweden on September 23, 1945. He got his M. Sc. in Electrical Engineering at the University of Lund in 1969.

His employment experience is with ASEA and later ABB. He has worked in the fields of high voltage testing, thyristor valve development, project management, commissioning of the Itaipu HVDC project in Brazil, system studies, engineering and since twelve years he is manager of the development of HVDC within ABB.



**Marc Jeroense** was born in Middelburg, The Netherlands on August 27, 1966. He got his M.Sc. in High Voltage Engineering from Delft University of Technology in 1992. From 1992 to 1997 he worked at the Dutch cable factory NKF in Delft and simultaneously got his PhD degree on the subject of HVDC mass impregnated cables. In 1997 he moved to Västerås, Sweden and worked for ABB Corporate Research on the topic of HVDC and highly stressed HVAC cable systems. In 2001 he moved to ABB's cable factory in Karlskrona, Sweden and had different positions as manager of the High Voltage Laboratory and technical product manager of HVDC-Light cable systems.



**Paulo Fischer de Toledo**, Lic.Eng., M.Sc.E.E: Paulo Fischer de Toledo graduated at Mauá Engineering Institute in São Paulo in Electrical Engineering. He has most of the time been working in the field of HVDC (High Voltage Direct Current) for Promon Engenharia and ASEA/ABB. Since 1996 he has been working with the system development and system design group in Ludvika, Sweden for ABB. He is Project Manager. He is also at Royal Institute of Technology in Stockholm perusing for PhD degree.