



Second International Symposium on Standards for Ultra High Voltage Transmission

800 kV UHVDC – From Test Station to Project Execution

**Abhay Kumar, Victor Lescale, Urban Åström, Ralf Hartings and Mats Berglund
ABB AB
Sweden**

SUMMARY

This paper presents the current status of the 800 kV UHVDC technology and presents how the experience and confidence gained at 800 kV long term test station is being utilised in executing 800 kV UHVDC long distance bulk power transmissions.

As a final step in the R&D activity, a long term test circuit installation was made & energised at 855 kV DC in November 2006 at STRI, Sweden in order to provide final qualification for the newly developed 800 kV products and boosting confidence in 800 kV HVDC technology.

Since then a number of 800 kV HVDC projects have entered the execution stage in China and India. At the same time, many other 800 kV DC projects are under planning by several utilities around the world, especially in China, India and Africa.

KEYWORDS

800 kV, Bulk Power Transmission, Experience, HVDC Transmission, Test Installation, UHVDC, UHV Transmission

abhay.kumar@se.abb.com

I. INTRODUCTION

In countries with growing populations and rising major economies like India & China, UHV offers the promise to meet the challenge to deliver large quantities of electricity from power generating stations to urban centres to meet the increasing intense demand of electricity. UHV is needed to deliver electricity to cities with a minimum number of transmission lines. In growing cities where demand is on the rise, but room for transmission lines is limited, this is further critical because it means only few power line corridors are available, not several.

800 kV Ultra High Voltage Direct Current (UHVDC) transmissions are economically attractive for bulk power transmissions, say above 5000 – 7000 MW, over long distances, say above 1000 – 2500 km [1]. The following transmission projects at UHVDC already in the execution phase: A) Xiangjiaba – Shanghai ± 800 kV HVDC Transmission (XS800), rated for 6400 MW, to transmit power over a distance of 1935 km, owned by State Grid Corporation of China, and B) Yunnan – Guangdong ± 800 kV HVDC Transmission (YUG800), owned by China Southern Power Grid, rated for 5000 MW to transmit power over a distance of 1418 km. For its part Power Grid Corporation of India Ltd. is driving its NER/ER – NR/WR Interconnector I ± 800 kV Multi-terminal HVDC Transmission (NEA800) project rated for 6000 MW to transmit power over a distance of around 1728 km to feed power into Agra and New Delhi area. The project is under the bidding phase. So is the Jingping – Sunan ± 800 kV HVDC Transmission (JPS800) project, which is rated for 7200 MW to transmit power over a distance of 1935 km, owned by State Grid Corporation of China. There are several other 800 HVDC transmission projects around the world which are in advanced stages of planning.

II. EQUIPMENT DEVELOPMENT

In order to meet the demands for such large projects, ABB has been running an R&D programme, well in advance, with the goal to develop and test the equipment and system tools needed for 800 kV UHVDC. The equipment R&D work focused on equipment connected to the pole voltage, with special attention to converter transformers, bushings and external insulation [2, 3]. The reasons for this become apparent in view of the principles exposed below. The most significant difference between equipment for HVDC compared with equipment for HVAC is the need for proper DC grading. The R&D on the system side focused on the advantages and disadvantages of the different possible configurations and modularization, with special attention to their impact on the reliability and availability of the transmission, but also with attention to their impact on the stresses imposed on the equipment.

When applicable, HVDC equipment is built up by modules where each module is provided with a proper resistive voltage grading resistor as well as an AC/transient grading capacitor. With a proper voltage grading, the voltage stress in each of the modules will be the same, regardless of if the module is part of an 800 kV apparatus or of a 500 kV apparatus. For some insulation systems the situation is more complicated, since it is normally not possible to arrange the DC grading with physical resistors: the DC grading must be secured by other measures.

For outdoor equipment exposed to pollution and rain/fog, the coordination between the internal and external voltage grading is also an important issue. Poor coordination can result in damage of the insulators due to radial voltage stress.

Not just designing or making prototype or testing these 800 kV equipments, ABB installed them in an energised test circuit to obtain first hand long term 800 kV operational experience [4, 5]. This was done to obtain confidence in the new technology as well as to gain time to resolve any unforeseen problem that might be revealed, and to verify the dimensioning of various parameters. In ordinary

conditions, newly developed equipment is qualified by a series of type tests. As most of the dielectric type tests are short duration tests, supported by operational experiences of earlier products at similar voltage level, such qualification are considered to be sufficient. However, as for equipment for 800 kV HVDC, there is no existing experience at this voltage level; to verify the design, it was considered by ABB of importance to examine the equipment in a relatively long time span. A good example being the need to verify the internal and external electric field design.

In AC, the field distribution is determined by the dielectric permittivity (ϵ , epsilon) of the insulation materials, while in DC the steady state field distribution is controlled by the resistivity (ρ , rho) of the insulation materials. In real service operation an equipment, typically the bushings, is exposed to both DC and transients of varying frequency. When switching on the voltage, an AC-like voltage distribution occurs, and after a certain time (corresponding to the “overall time constant” of the insulation system, $\tau = \rho * \epsilon$), the DC-like field distribution is obtained. Due to the complex nature of the insulation system, the geometry and position of the different parts, the transition from “AC to DC” may occur very differently in different locations inside and outside the bushing.

The resistivity of the insulation materials of a bushing is of course very high; besides, it is heavily temperature dependent. As a result, the typical overall time constant can vary by several orders of magnitude and can be very long. In fact, hours, days, or weeks are quite typical. It is therefore important to verify the electric field distribution also in its “natural” environment, e.g., at valve hall temperatures of up to 40-50 °C. Thus a long term test using a ‘heated valve hall’ was considered to simulate the real time stresses.

III. LONG TERM TEST CIRCUIT

In order to verify the long term behaviour of the 800 kV HVDC equipment, all relevant pieces of equipment were installed in a long term test circuit at STRI in Ludvika, Sweden (see Fig. 1), and energized at 855 kV DC, in November 2006.



Fig. 1. 800 kV HVDC long term test circuit installation at STRI, Sweden.

The test circuit includes a “valve hall” where the temperature is kept at about 50 °C, to simulate the actual operating conditions for the bushings. The transformer bushing protrudes inside the “valve hall” and is connected to the wall bushing. The remaining equipment is installed outdoors. In addition to the

components, support insulators, electrode forms, bus configuration, etc were also tested. In total, the following equipment (test objects) was included in the test circuit installation:

1. Transformer prototype
2. Wall bushing
3. Optical current transducer
4. Voltage divider
5. Pole arrester
6. Smoothing reactor prototype
7. RI Capacitor
8. Disconnecter
10. By pass breaker

All equipment in the test circuit has been operating as expected and no failure was reported. The polarity of test circuit was changed from positive to negative on May 4, 2007, after several months of successful operation. While making stop at positive polarity, measurements of the electric field strength around the transformer bushing were performed at 300 kV, and as well while starting at negative polarity. During 855 kV DC in the test circuit installation, several variables were continuously recorded, which included ambient conditions, surface leakage currents, electrical field strengths, gas in oil analysis. In addition videotaping of the energizing was performed when snow was laying on the wall bushing. With an infrared camera, recordings of the heat transmission through the wall bushing during cold weather were also made.

Successful operation of this long term test installation for more than a year, provided the necessary confidence in the 800 kV UHVDC technology at an early date, which resulted in planning and boosted confidence in execution of 800 kV UHVDC transmission projects in several countries.

IV. XIANGJIABA – SHANGHAI \pm 800 kV HVDC TRANSMISSION PROJECT

The first stage Jinsha River Development Project is located in the area of Sichuan province and is larger than well known Three Gorges project. It includes the construction of several hydro power stations in the Jinsha river valley. The dam construction began in 2005. Four hydro power stations will be constructed: In order from downstream to upstream, Xiangjiaba Left Bank Station, Xiangjiaba Right Bank Station, Xiluodu Left Bank Station and Xiluodu Right Bank Station. The nominal rated power capacity of each generator unit is 750 MW. The total number of generators will be 26 and the generation capacity will reach 18 600MW. The first generator is scheduled to be commissioned by the year 2012 and the completion of the whole project is scheduled for 2017.

The 6 400 MW Xiangjiaba – Shanghai \pm 800 kV DC Transmission Project is a bipolar transmission having one converter station in Fulong (in the YiBin area of the Sichuan Province) and the other in Fengxian (in Hengqiao town within the city of Shanghai) in the People's Republic of China. The Fulong rectifier converter station is located approximately 8 km from the site of Xiangjiaba hydro dam. As shown in Figure 2, Fulong will be connected to Xiangjiaba power stations by four 12-15 km long 500 kV AC lines. Fengxian will be connected to the AC system by three 4 km long 500 kV AC lines to the station Nanhui, which is part of the 500 kV AC ring around Shanghai city.

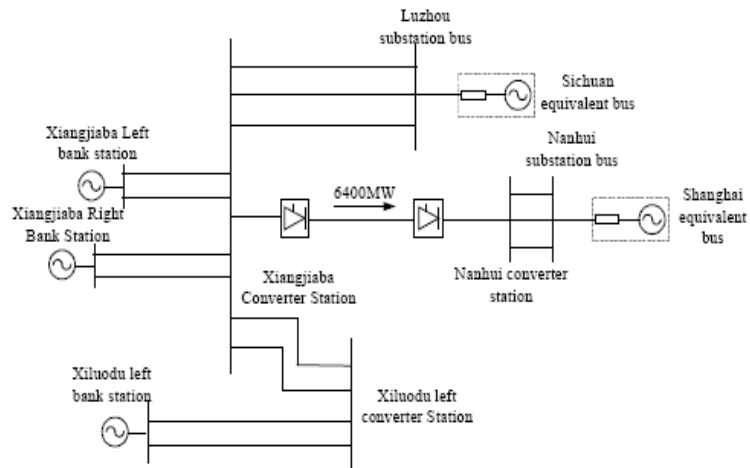

Fig. 2. Power system around the Xiangjiaba – Shanghai ± 800 kV DC Transmission Project

V. DESIGN FEATURES

A simplified single line diagram of Xiangjiaba – Shanghai HVDC Project is shown in Figure 3. The bipolar system is rated for a continuous power of 6 400 MW (± 800 kV DC, 4 000 A) at the DC terminals of the rectifier converter station. The transmission is designed to transmit full rated power up to the specified maximum ambient temperature without any redundant cooling in service. With redundant cooling in service, a continuous overload of 105% and 2-hour overload of 113% of rated power are achievable. With lower ambient temperature, the overload can be even higher i.e. for an ambient of 20°C, a continuous overload of 115% and 2-hour overload of 131% of rated power are achievable.

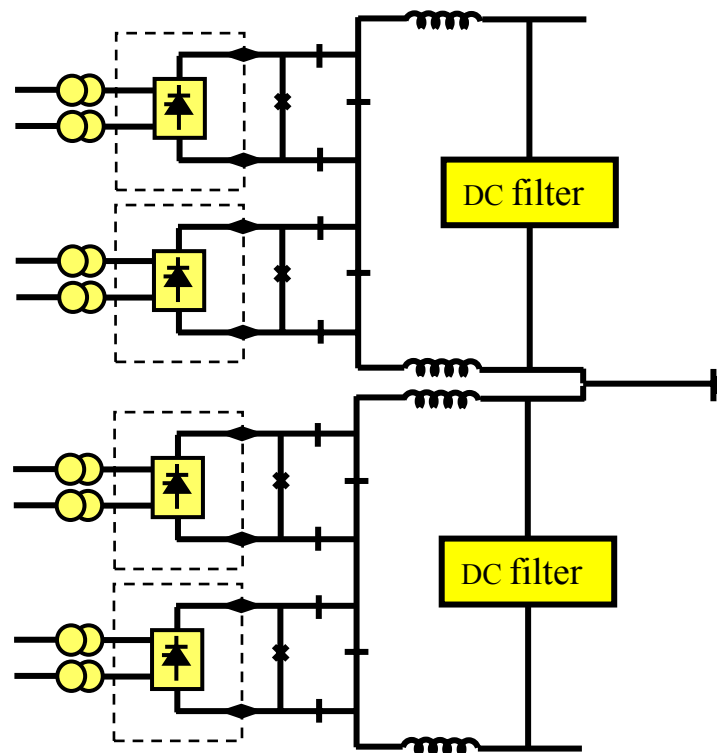

Fig. 3. Overview single line diagram of Xiangjiaba – Shanghai ± 800 kV DC Transmission Project, clearly showing the two-series converters per pole.

VI. MAIN EQUIPMENT AND MAJOR TECHNICAL FEATURES

For the converter bridges, air insulated, water cooled thyristor valves, arranged in double-valve configuration are suspended from the ceiling of the valve hall. Each single valve consists of 56 numbers YST130 (6") type thyristors in Fengxian. These thyristors have been specifically developed for high current applications.

In the XS800 project, single-phase, two-winding converter transformers are used. Part of the transformers is manufactured in China and part in Sweden. Cooler banks are mounted on tank itself, even though in Fengxian station an audible noise mitigation arrangement has been adopted. Both wye and delta valve winding bushings protrude inside the valve halls. Main data of Fengxian converter transformer is as given in Table 1.

Rated Power [MVA]	297.1
Rated Voltage [kV]	
- Line winding	515
- Valve wye winding	$157.6 / \sqrt{3}$
- Valve delta winding	157.6
Leakage Reactance [%]	16.8
Tap Changer Range [Steps]	+22, -6
- Step Size [%]	1.25
Insulation Level [kV]	
- Line side LIWL	1550
- Valve wye side LIWL	1800
- Valve delta side LIWL	1550

Table 1

The smoothing reactors are of air insulated type, and two units are installed per pole on the high voltage side [800 kV_{dc}] and two units are installed per pole on the neutral voltage side. The main data for each of the smoothing reactors is as given in Table 2.

	Fulong/Fengxian
Nominal Incremental Inductance [mH]	75
Rated Current [A _{dc}]	4000
Insulation Level [kV]	
- LIWL, terminal to ground	NA
- LIWL, terminal to terminal	1175

Table 2

Manufacturing of various equipment is progressing in various works satisfactorily to meet the target schedule of commissioning as per following:

Pole 1	December 2010
Pole 2 and Bipole	June 2011

VII. CONCLUSIONS

800 kV UHVDC is economically attractive for bulk power transmission over long distances. With

the satisfactory progress of R&D efforts, converter equipment for 800 kV UHVDC is fully qualified and projects are being executed by the several utilities.

A long term test installation was energised in November 2006, and had performed satisfactorily without any problems and has provided confidence in ABB's design for 800 kV HVDC equipments including design of electrode arrangements and bus-bars. With the confidence gained with satisfactory operation of the long term test circuit, the conclusion is that 800 kV DC will account for a significant part of world growth in power transmission capacity over the next several years.

VIII. ACKNOWLEDGMENTS

The authors gratefully acknowledge the contributions of Mr. Björn Englund for his work on the long term test circuit and support extended in writing of this paper.

BIBLIOGRAPHY

- [1] Urban Åström, Lars Weimers, Victor Lescale and Gunnar Asplund, "Power Transmission with HVDC at Voltages Above 600 kV," in IEEE/PES Transmission and Distribution Conference & Exhibition: Asia and Pacific, August 14-18, 2005 Dalian, China.
- [2] U. Åström and V. Lescale, "Converter Stations for 800 kV HVDC," in CEPSI 2006, Mumbai, India, 2006.
- [3] U. Åström and V. Lescale, " Verification of equipment for 800 kV HVDC," in International Workshop for Ultra High Voltage (UHV) Transmission Systems 2006, Beijing, China, Nov. 28 - 29, 2006.
- [4] U. Åström, V. Lescale, D. Wu and G Isacsson, "Latest Development in transmission in 800 kV DC," in GridTech 2007, New Delhi, India, Feb. 5-6, 2007.
- [5] Abhay Kumar, Dong Wu and Ralf Hartings, "Experience from First 800 kV HVDC Test Installation," ICPS 2007 - International Conference on Power Systems, CPRI, Bangalore, December 12 – 14, 2007.