

Investigations of different Function Allocations in SA Systems enabled by IEC 61850

Klaus-Peter Brand, *Senior Member, IEEE*, and Wolfgang Wimmer

Abstract— At least since 2006 the standard IEC 61850 for communication in substations is in commercial use providing interoperability in Substation Automation systems between devices from different suppliers. Its approach is based on the split between applications and communication, functions and implementation and, therefore, supports also the free allocation of functions to IEDs. This allows the question for an optimal allocation regarding the functional requirements of SA, its impact on the communication system, performance of functions, engineering effort and reliability, and on the cost level. Common SA systems are some mix between a total centralized and decentralized allocation providing the well-known functions on station, bay and process level. The two extreme solutions are positioned and it is evaluated if the common mix is an optimal one. The result is a proposal for the best allocation of existing functions to IEDs. Depending on given functional requirements and not too strict boundary conditions, improvements are possible exploiting the full capabilities of IEC 61850, if accepted.

Index Terms – Substations, substation automation, communication, communication architectures, protection, control, IEC standard, IEC 61850, function allocation, reliability, performance, optimization, centralized and decentralized systems

I. INTRODUCTION

Substation automation (SA) is commonly used in controlling, protecting and monitoring of substations [1]. Up to now, the communication for SA has used private serial communication systems complemented by conventional parallel copper wiring, especially between the process (switchgear) and the bay units. With the finalization of IEC 61850 [2] in June 2005, there is a comprehensive global standard for all communication needs in the substation being introduced now. The standard provides *interoperability* of devices from different vendors, which has been proven not only by demonstration and pilot systems, but also by a lot of commercial substation automation systems set in operation mainly in 2006 and beyond. Another important feature supported by IEC 61850 is the *free allocation of functions to physical devices* (IEDs) which is addressed in this paper.

The approach of IEC 61850 separates application and communication. The application is represented by the object oriented data model with standardized basic function atoms called Logical Nodes (LN) classes which contain the function related standardized data. LNs can be grouped for managerial and organizational purposes in to Logical devices (LD) which are hosted by physical devices. The

access to the data is open by standardized communication services. Both together and the allocation of LNs to the switchyard elements (single line) is described in the Substation Configuration description Language (SCL) for interoperable exchange between engineering tools. The data and communication model is mapped to a main stream communication stack consisting of MMS, TCP/IP and Ethernet [2].

The allocation of functions in terms of LDs and LNs to physical devices (IEDs) may have a strong impact on the communication architecture, on reliability, investment cost, and engineering effort and maintenance of the SA system. Especially, the reliability has also an impact on the overall network management system, and therefore on the reliability of power supply in general.

Up to now, functions in SA systems are allocated in a very traditional, fixed way to IEDs. These fixed devices are normally applied on *bay level* with an interface to the switchgear on *process level* and others to HMIs at station and bay level, and to a gateway to the network control center (NCC) on *station level* (see Figure 1). In case of serial links they are called process bus and station bus. There are some minor deviations, e.g. combined IEDs for protection and control on MV or distribution level, and the disturbance recorder function built into most protection IEDs today. There is the implicit assumption that this approach is the optimal one. The standard IEC 61850 allows many other allocations and related communication architectures. An evaluation of the reliability of different communication architectures enabled by IEC 61850 was made already in [3].

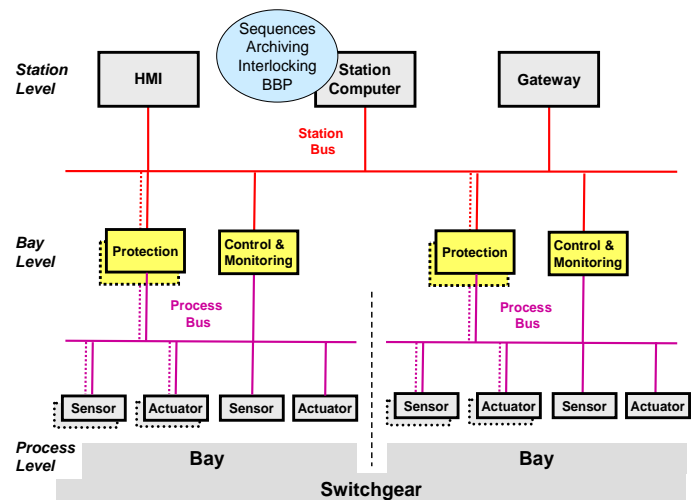

Figure 1 – Common structure and function allocation in SA systems

II. THE FREE ALLOCATION ACCORDING TO IEC 61850

IEC 61850 provides not only interoperability, but supports also the *free allocation of LNs to physical devices* to be open for different design and operation philosophies of the utilities world-wide. Important for the future is that this approach opens the door for an assessment of given SA solutions and to ask for the optimized solution proofing the existing traditional ones or claiming for new ones based on the well known functions needed by the utilities in SA systems. This new degree of freedom enabled by IEC 61850 may result also in developments extending the functionality of the substations and SA system for the benefit of the overall power system. It should be noted that any packaging of functions has an impact on the SW implementation and, therefore, is within the responsibility of the suppliers responding to market needs.

III. BASIC EXAMPLES OF FUNCTION ALLOCATIONS

One extreme example is the allocation of all functions needed in the substation to one *central computer* at station level collecting with a vast number of sensors at process level all data needed, and is issuing any actions like commands and trips via remote outputs (actuators) at process level again. There are no bay level and no dedicated IEDs for protection, control, monitoring and other functions anymore. Since the necessary computation power was in the past available in big computers only, such solutions had been proposed at the very early beginning of substation automation. They may now see a revival because of the powerful communication services standardized by IEC 61850. There is no discussion that such a centralized computer has to be duplicated to avoid a very dangerous single point of failure (see Figure 2). The loss of sensors and/or actuators is a problem left for the adaptability of functions facilitated by the comprehensive data image in these centralized computers. The bay level control has to be connected also to these central computers, making it more vulnerable against cable faults in the system.

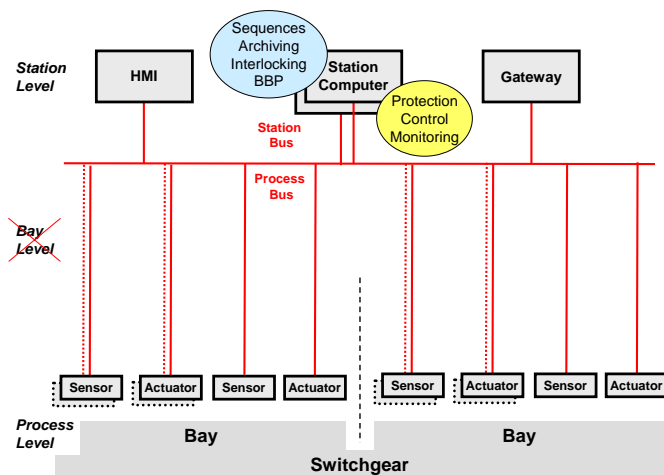

Figure 2 – Totally centralized SA system with sensors and actuators

The other extreme example is the total distribution of all functions, maybe down to one LN per IED. The related IEDs will be both on bay and process level depending on

their functionality. The station level is consisting of an HMI with work place functionality only and of a gateway to the NCC. The IEDs can be physically clustered as optimal needed from reliability or maintenance point of view. Also this solution is supported by the powerful communication standardized by IEC 61850 providing the independence of the data model and communication services from implementation. Any single IED failure refers only to one atom of functionality. The influence of a function atom failure on the functions must be minimized by an appropriate design (see Figure 3).

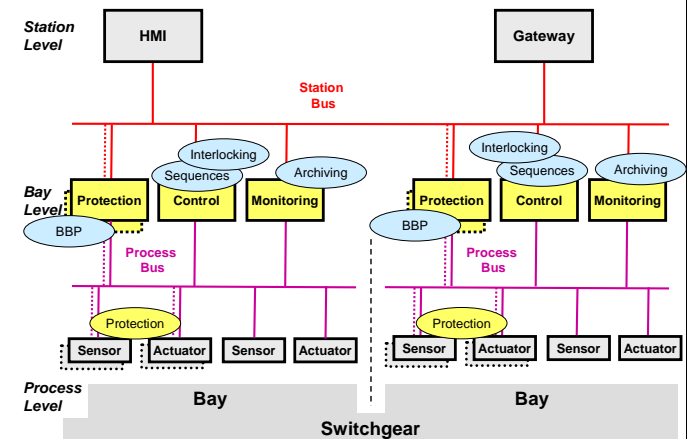

Figure 3 – Toward a totally decentralized SA system (schematic)

The most SA systems today have populated all three levels with functions in multifunctional IEDs. At station level, the computer is not only providing an HMI, but also functions for the complete substation like event and alarm lists, an archive for historical data and e.g. functions like a sequencer supporting the local or remote operator. At bay level, dedicated IEDs for functions like protection, control, and monitoring exist. With the use of a serial link (“process bus”) according to IEC 61850 between the bay and process level, also at process level IEDs with sensor or actuator functions may be found (see Figure 1). Multiple measures are taken to overcome single point failures and to increase reliability. Therefore, the common solution with process bus looks like an intermediate one mixing benefits and drawbacks of both extreme ones. The paper tries to answer the question for the optimal solution regarding the functionality requested in the substation, and all related criteria.

IV. EVALUATION CRITERIA

A. Load on the communication system

The load on the communication system is different for different architectures as result from different function allocations. Especially, the load of the communication interface per IED is strongly dependent on this allocation. Since the functions including their data exchange have to be performed with the same performance independently where they are implemented, the needed performance of the IEC 61850 implementation may restrict the free allocation in some cases.

B. Reliability

The reliability of communication depends on the resulting communication architecture with all links and communication components like switches. The reliability of different communication architectures based on IEC 61850 was evaluated already in [3]. The allocation of ‘function atoms’ to IEDs influences the physical architecture needed for the function implemented and, therefore, the reliability of the function. Especially, more IEDs results in more switch ports and therefore in more or bigger switches.

C. Engineering effort

The number of IEDs for the allocated LNs, the complexity of the functions per IED, and the complexity of communication increases the engineering effort and the power needed by the system engineering tool. The IEC 61850 approach of decoupling functions from the physical IEDs and the communication architecture can again decrease the engineering effort. The semantic included in the definition of the Logical Node classes and their Data Objects supports even automated function engineering or at least consistency checks. If such an approach is fully used, the engineering effort for all kinds of solutions with same functionality will be decreased and in the same order.

D. Costs

Detailed costs of a SA system are depending on the technology and the market approach of the provider and the competition on the market. In general, based on the application different classes of IEDs may be classified by cost tags based on the computation requirements. It may be assumed that sensors and actuators work only with GOOSE and SV services. Devices with exactly one functional LN are supporting all services. Similar today, IEDs containing groups of about 20 LNs have also to support all services but need also higher computation power due to more functions performed and data communicated. Finally, the highest processing power for both functions and communication is needed by the central IEDs containing the LNs of all functions needed in the complete substation. A very rough cost estimation results in the following data in Tab. 1.

IED Class	Description	Relative Cost
SAI	Sensors and actuators process bus (PB) interface	0.2
LNA	Single function LN	1
BU	Multi function LNs (about 20)	2
CU	Central LN processing (all – e.g. 400 - LNs)	20

Tab. 1 – Relative IED costs

V. FUNCTION IN SA SYSTEMS (EXAMPLES)

A. Distributed control functions

Since already simple commands depend on the sequence of steps between the HMI at station level or in the remote NCC, the bay controller and the process interface, there are no real *local* control functions. In most cases, commands are checked against interlocking and synchrocheck conditions arising from relevant subparts of the substation or from the complete one. Automatic sequencers may be used acting at

the complete substation. Different allocations of the included functions to IEDs will result in more or less optimized solutions.

B. Local protection functions

Bay local protection functions are functions which need only voltages and currents from one bay and act in any case on the breaker in this bay only. There is a weak informative link e.g. to the HMI. If the voltage and current samples are coming from different places over the process bus, the behavior is getting non-local and more depending on the allocation.

C. Distributed protection functions

Some protection functions need information from many bays or act on different breakers by definition like busbar (BB) protection or breaker failure protection. Such functions behave sensitively to their allocation to IEDs.

VI. EVALUATION

In the following only configurations with process interfaces to the switchyard are considered. This interface is always located in the switch gear and a process bus used.

A. The extremely centralized case: Benefits and drawbacks

The totally *centralized* solution as given in Figure 2 consists of a redundant functional node (protection, control, monitoring, etc.) at station level interacting with all sensors and actuators of the SA system at process level constituting the remote process interface.

1) Load and Performance

The assumption for the communication load calculation is that each voltage (LN TVTR1) and current transformer (LN TCTR1) is producing sampled value (SV) messages with sample rate of 4000 Hz and length of 1 kBit per message, and that each switchgear (LNs XCBR1 or XSW11) and the centralized protection and control is producing one GOOSE message/s (msgs/s) with the length of 10 kBit each. Commands are contributing same as GOOSE messages.

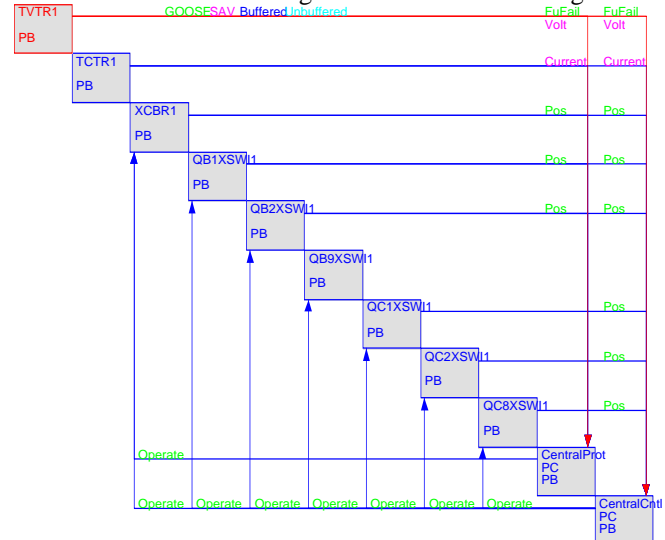

Figure 4 – Central solution with 1 bay connected

In Figure 4 the communication in a process bus (PB) type network between the central combined protection and control unit and the sensors and actuators for one bay with 2 instrument transformers and 7 switching devices is shown. The resulting load per such a sub-network is 8090 kBit/s or 8009 msg/s. The throughput limit given by the actual version of IEC 61850 is 100 Mbit/s per line. Switches having also ports with 1 GBit/s are available and mostly used for backbone links. To avoid collisions on the Ethernet and support priorities as requested by IEC 61850, managed switches have to be used which have a throughput in the order of 200'000 msg/s. Therefore, the calculated load for one typical bay means that such a solution with centralized functions can handle around 10 bays per sub-network or network segment related to a 100 Mbit/s link to the central IEDs, and around 20 bays related to the switch message throughput. Due to the needed high amount of input processing capacity, especially for samples (SV messages), such a group of 10-20 bays may need a separate sample pre-processing unit within the centralized function unit.

2) Loss of sensors and actuators

Regarding the effort for sensors and actuators and the communication load, in most cases (except complete separation of main1 from main2 in HV protection) these components will not be duplicated. Therefore, the most important drawback of such a solution is the impact of the loss of a sensor or an actuator or of the related communication link. The MTTF of sensors and actuator may be assumed to be at least 200 years, SA proof switches as far as needed have currently around 50 years. The centralized common data base of the complete substation offer the basis to compensate some losses, but innovative new algorithms are needed to handle this problem.

B. The extremely decentralized case: Benefits and drawbacks

The overall functionality of the totally *decentralized* solution as indicated in Figure 3 consisting of many functions or function groups is implemented by communication between many decentralized IEDs at bay level, each hosting one LN.

1) Load and Performance

The assumptions about the messages generated are the same as above but the results are different by the different topology. What is shown in Figure 4 as CentralProt and CentralCntl now becomes a single function processor, e.g. for instantaneous overcurrent protection (PIOC), for synchrocheck (RSYN) or for switch control (CSWI), and is multiplied up to one IED per LN needed for the function considered. These LNs add a few GOOSE messages for communication in between them, and some reports for supervision and operation purpose to and commands from station level. If we assume typical the implementation of 20 LN instances of different LN classes for bay functionality, this adds around 40 msg/s resp. 40 kBit/s. Report messages from a bay unit both to the IHM and NCC gateway may be assumed to contribute with a message size same as the GOOSE messages, and sent once per second.

Figure 5 illustrates the load between the bays and to station level. Commands are sent from the HMI (LN IHMI1) and NCC gateway (LN ITCI1) at station level to the bay control (Ctl1). Reports are sent from the bay control (Ctl1) and bay

protection (Prot1) to the station level (LN IHMI1, LN ITCI1). If applicable the fuse failure from the voltage transformer (LN BB1_TVTR1) is also reported. The trip of protection is sent by GOOSE message to the control in the same bay e.g. for autoreclosure start. The positions of the switchgear are exchanged between bays represented here by Ctl1 and Ctl2 with GOOSE messages for interlocking. Same happens for the positions from Ctl1 to Prot1. If applicable the voltage of the busbar VT (BB1_TVTR1) is send as SV message to the bay controller (e.g. Ctl1) for the synchrocheck function.

The resulting load per bay in such a sub-network including the voltage samples is 4038 kBit/s or 4011 Msgs/s. The main load comes from the busbar VT since the calculation without this VT results in 36 kBit/s or 9 msg/s.

This means, that if the bay level samples can be hidden from the interbay bus (IBB), at least 1000 bays can be served by the sub-network without distributed synchrocheck or, generally, without broadcasting samples of current and/or voltage. In this case, the real bottle neck is the throughput into the station level IEDs. If this would be 1000 msg/s, around 200 bays are possible. The synchrocheck adds around 4 Mbit/s, i.e. 1 Busbar VT corresponds to the load of 100 bays without sampled analogue values (SAV). If we stay with 100 bays resulting in maximum to loads of about 4 MB/s, roughly 20 VTs could be handled in addition. This then relates either to a maximum of 20 bays or 20 bus bar segments depending where the busbar VT values are created and how communicated. This means that in the 'conventional' architecture with BB VT values onto the IBB around 20 HV bays could be handled. Also 20 bus bar segments with totally up to 100 bays seem to be a reasonable size, without technical problems. If for medium voltage (MV) the sampling rate may be lower, this figures could be even higher. The critical factor then becomes the input processing capacity of the IEDs.

There is also a direct interaction between the bays including the exchange of current samples for busbar protection, which is not considered above; for MV systems it is seldom used, for HV systems it is normally a separate network.

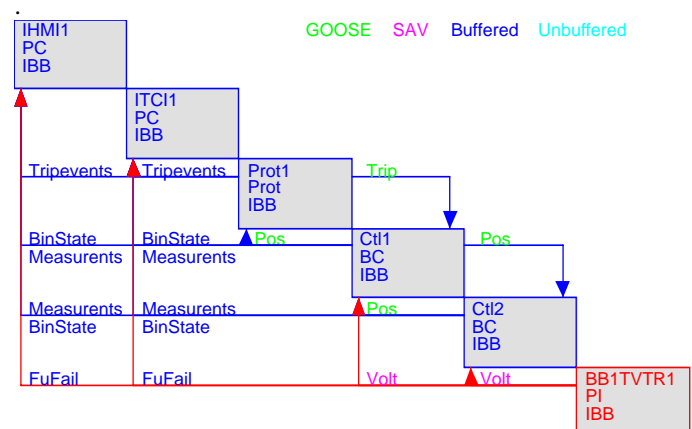

Figure 5 – One conventional bay exchanging Interbay data and receiving samples from busbar VT

2) Loss of single functions or function groups

This decentralized solution is very sensitive to the *loss of a single LN involved in multiple functions*, caused either by the loss of the allocated IED or of relevant communication links. The station level consists of the HMI only. Therefore, a certain redundancy of functions as already common at HV level as main1 and main2 protection or as back-up protection may be requested in general. It is mainly needed for single LNs acting as interface to the process or for functions being commonly used by more than one other function like autoreclosure (represented by RREC) and the trip conditioning matrix (represented by PTRP). For communications redundant or duplicated systems may be necessary and useful [3].

C. Today's allocation: an optimal solution?

- Case 1: *Station and process bus physically separated*

The most common SA architecture shown in Figure 1 is based on the allocation of functions to some more or less dedicated IEDs. All IEDs have an interface to the process data of this bay, and a second interface to the station bus communication to the station level and between the bays.

- Case 2: *Common bus for station and process communication*

The bay level functionality is allocated to bay level IEDs which exchange data by one interface and one switch both for process bus data and interbay and station data as described in [3] as solution in Figure 7.

1) Load and Performance

Case 1 separates station bus traffic from process bus traffic by architecture. The critical point to be solved is how some process data needed in other bays can be brought to the station bus side (e.g. voltages for Synchrocheck).

Case 2 has not this problem, but the separation must be handled by careful configuration of the switches e.g. by VLANs. This separation assures that the very high amount of about 200 bays can be handled.

2) Loss of components

If we loose one protection IED (e.g. main 1), there is at least on transmission level a second protection (main 2) available. It should be noted that main1 and main 2 have some other purpose beyond redundancy (diversity in fault detection characteristics). The MTTF of control IED is mostly sufficiently high, and the loss of one bay regarding control is in most cases acceptable, especially if there is an emergency device directly at the switchgear.

The loss of sensors and actuators leads to loss of the part of the functions. Critical are the sensors both for current (TCTR) and voltage (TVTR), and the circuit breaker interface XCBR. The loss of the circuit breaker can be handled for protection purpose by the breaker failure protection.

VII. CONCLUSIONS

The *fully centralized solution* is limited both by the communication and processing capability. The risk to be dependent from the central configuration tools of one supplier is high, and no retrofit or expansion with other solutions is possible. A bay level HMI is more vulnerable against communication system faults, because it is also connected to the central IED.

The *fully decentralized solution* (one function atom per

IED) needs careful configuration of the communication system to limit the data flow. The demand for processing power is more on the communication side than on the functionality side. Therefore, this solution is not very cost effective. If we apply the estimation of Tab. 1 to system sizes of 5, 10 and 20 bays each with 20 Logical Nodes, the system hardware costs relate as follows (sensors and actuators neglected because they are the same in all cases).

Cost/Case	Distributed	Conventional	Centralized
5 bays	100	10	40
10 bays	200	20	40
20 bays	400	40	40

Tab. 2 – Cost comparison of systems

The today's *bay oriented solution* shows a reasonable function allocation (some functions per IED), is best adaptable to system size, and costs are never higher than the centralized solution. It allows the maximum system size with reasonable reliability and reasonable communication system engineering effort (see Tab. 3). Similar improvements in reliability as in the central case against loss of sensors with relatively low costs may be possible by having a central IED per busbar section and function group (Control, Protection) instead of per complete system. The data flow between busbar sections and system level is minimized and the functional redundancy can be used to some degree. To exploit this solution the development of some new distributed algorithms is needed. The relative positioning regarding cost may be influenced by future advances in technology and could be even lower than for the conventional solution.

Case	Distributed	Conventional	Centralized
Maximal number of bays	100 - 200	200	10-20
Reliability	Only single function concerned	Loss of one bay tolerated	Compensate loss of one sensor; bay HMI vulnerable
Switch configuration effort	High (VLAN config..)	Low to medium (VLAN config.)	Low

Tab. 3 – Comparison of system parameters

A general architecture like the conventional one, combined with communication architecture as suggested in [3] Figure 8, seems favorable at the current state of technology. With decreasing processing costs some degree of centralization for some functions, e.g. distance protection per bay, bus bar protection, control per station, might become more cost effective, but they mostly need some development and, more hindering, an acceptance by the utilities as users. In any case the roadmap to future systems is given. To allow

approaching the optimal function allocation by any future retrofit or add-ons as well as having minimal engineering effort, it is recommended to always model each SA system at the LN / LD level as if it would be completely distributed. Any dedicated project may have all solutions at disposal, but may be limited by some boundary conditions. Therefore, the best system design remains still a challenge for the skilled substation automation system engineer.

REFERENCES

- [1] K.P.Brand, V.Lohmann, W.Wimmer “*Substation Automation Handbook*”, UAC 2003, ISBN 3-85759-951-5, 2003 (www.uac.ch)
- [2] IEC 61850 “*Communication networks and systems in substations*”, 2002-2005 (www.iec.ch)
- [3] L.Andersson, K.P. Brand, Ch.Brunner, W.Wimmer “Reliability investigations for SA communication architectures based on IEC 61850”, IEEE PowerTech 2005, St.Petersburg, Paper IEEE_PPT05-604

Klaus-Peter Brand (SM'89) was born in Neustadt/Aisch, Germany, in 1948. He studied Physics in Würzburg, Kiel, and Bonn (Germany). He got his Master (Dipl.Phys.) and his PhD (Dr.rer.nat.) from the University of Bonn. 1976, he joined the plasma physics group (SF₆) of BBC/ABB Research Center in Baden, Switzerland. From 1982, he was in different positions strongly involved developing substation automation systems and building up this business in ABB, Switzerland. He is working at the ABB University Switzerland as instructor and consultant. He is engaged in CIGRE SC B5. From 1995, he is being member of the AHWG and WG10 of IEC TC 57 worked from the beginning defining the standard IEC61850. He is acting now as expert, editor and co-editor of parts of this standard for maintaining and creating the 2nd edition. He is also chair of the Swiss chapter of IEEE PES.

Wolfgang Wimmer, was born in Bad Schwartau, Germany, in 1947. He studied Mathematics and Computer Science at the University of Hamburg (Germany), and also got there his Master (Dipl.Inf) and his PhD (Dr.rer.nat.). In 1979 he joined BBC/ABB in Baden, Switzerland. From 1983, he was in different positions strongly involved developing substation automation systems and building up this business in ABB, Switzerland. He is working presently at ABB Utility Automation, Switzerland, as principle systems engineer in the development of substation automation and monitoring systems. From 1996 he is a member of IEC TC57 WG10 working on the standard IEC61850. He is acting now as editor and co-editor of some parts of this standard.