

DynaPeaQ[®] Energy Storage System – A UK first



UK Power Networks has installed a DynaPeaQ[®] dynamic energy storage system at a site in Norfolk in England in collaboration with ABB and Durham University. The system is based on ABB's SVC Light[®], combined with a Lithium-ion battery storage and is located in an 11 kV grid with considerable penetration of wind power.

Interest in electrical Energy Storage Systems (ESS) is increasing as the electricity supply industry is faced with growing pressures including the accommodation of distributed generation, management of ageing assets and avoidance of network reinforcement. Among other things, energy storage can be expected to help overcome the issues of intermittent power production (such as wind and solar), and in a Smart Grid development perspective, energy storage should come to play a natural part.

This is the first time an electrical energy storage device has been installed on an 11 kV distribution network in the UK. Commissioning of the installation was finalized in the spring of 2011.

The project was financially supported through GB regulator Ofgem's Innovation Funding Incentive scheme.

The integration of energy storage systems into transmission and distribution networks has the potential to provide significant benefits at all points in the supply chain. Increased penetration of Distributed Generation (DG), particularly based on renewable energy resources, is driving the need for distributed energy storage to provide services that will allow existing network assets to continue to deliver reliable, high quality electricity.

The installation will yield dynamic voltage control in the 11 kV distribution system and at the same time enable dynamic storage of surplus energy from wind farms, which can be utilized to level out peaks in grid loading and enable increased grid stability. Using this strategy, it should be possible to enable the power harnessed from the wind to be put to more efficient use than would otherwise be possible.

The dynamic energy storage system deployed by UK Power Networks was designed and built as a turn-key project by ABB. It is an add-on to the well established ABB SVC Light, a fast PWM (Pulse Width Modulation) controlled, IGBT based converter used for tasks such as voltage control, flicker mitigation and active filtering.

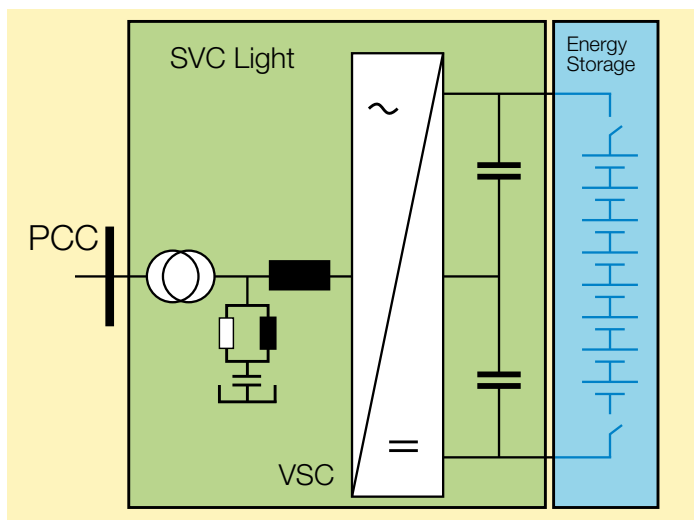

Fig. 1: Single-line diagram of DynaPeaQ

Li-ion battery technology was selected for its long calendar lifetime, high power density, and high round-trip efficiency. Safety and protection is ensured by interlocking and supervision and control from cell to system level.

Test network

A site was selected such that the maximum number of benefits with the ESS could be considered from a single installation. A rural 11 kV distribution network in North Norfolk with a 2.25 MW wind farm connection was selected. The storage device is installed at a normally open point between two primary substations, near the remote ends of 11 kV feeders from the substations. Only one feeder is connected to the ESS at any single moment, but it is easy to switch between feeders, allowing for different operational scenarios. Physical network information such as line and transformer data is provided by the Distribution Network Operator (DNO) as well as half-hourly operational data comprising feeder current and DG output.

A mixture of residential areas, rural areas and seasonally occupied accommodation are supplied by the feeders in this region. The typical load on the feeders is 1.15 MW and 1.30 MW with peaks of 2.3 MW and 4.3 MW respectively. The wind farm with 2.25 MW installed capacity is attached midway along the first of these feeders. This installation has fixed speed induction generators, so there is significant reactive power demand while generating.

Daily load profiles show that the two feeders have quite different characteristics. On the first, the most significant demand occurs during the night, due to a high number of homes heated by night storage heaters. Summer loading is lower than during winter. The second feeder has much less storage heating, and in this case summer loading is higher than during winter. These dissimilar characteristics mean that events requiring ESS support are likely to occur at different times, maximising the utilisation of the ESS.

A range of modelling and simulation work has been carried out by Durham University to evaluate the most effective way to operate the ESS on a distribution network.

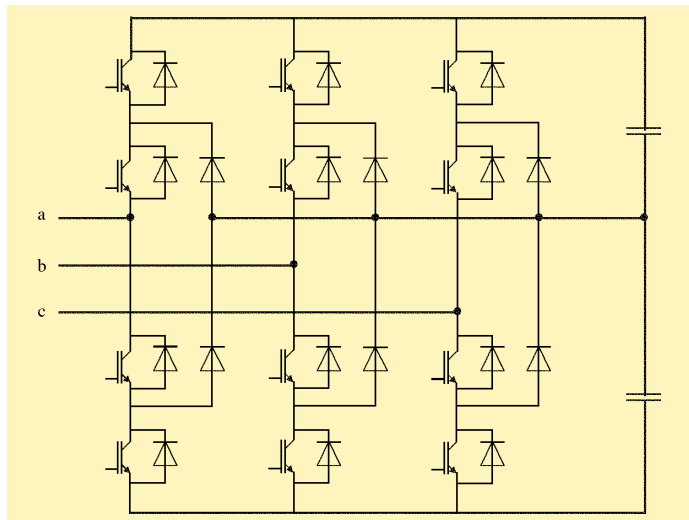

Fig. 2: 3-level VSC configuration

Funding for the monitoring and evaluation phase of the work has been secured from the GB Regulator Ofgem as a Tier One Low Carbon Networks Fund (LCNF) project together with matching funding from ABB.

Main circuit design

The size of the energy store was determined by the cost that could be reasonably justified as an R&D project. ABB integrated a battery system with an SVC Light based on a Voltage Source Converter (VSC) to enable independent sourcing or sinking of real power up to 600 kW and reactive power up to 600 kvar (Fig. 1). The DC side of the VSC is connected to Li-ion batteries with a capacity of 200 kWh. An ABB MACH 2 control system controls both the VSC and the battery system. A dry-type step-down transformer rated at 1 MVA is employed to optimize the VSC voltage.

The VSC has a nominal rating of 850 kVA. A passive harmonic filter rated at 125 kvar and tuned close to the 37th harmonic is installed to satisfy harmonic requirements at the 11 kV Point of Common Connection (PCC).

The DynaPeaQ has a dynamic reactive power range from 600 kvar inductive to 725 kvar capacitive. The battery storage connected to the DC side of the VSC can deliver 200 kW for one hour, or 600 kW for a short period.

The design is based on IEC standards for both outdoor and indoor equipment. The design is also based on the vast experience gathered from other plants utilizing SVC Light.

VSC

In the VSC, there are four IGBT valves and two diode valves in each phase leg (Fig. 2). The valves are built up by stacked devices with interposing coolers and an external pressure applied to each stack. Water cooling is utilized for the valves, giving a compact converter design and high current handling capacity (Fig. 3).

One side of the VSC is connected to a capacitor bank, which acts as a DC voltage source. The converter produces a variable AC voltage at its output by connecting the positive



Fig. 3: Converter valve stacks

pole, the neutral, or the negative pole of the capacitor bank directly to any of the converter outputs. By use of PWM, an AC voltage of nearly sinusoidal shape is produced without any significant need for harmonic filtering. This contributes to the compactness of the design, as well as robustness from a harmonic interaction point of view.

Battery storage

The battery system is composed of eight identical Li-ion battery stacks in series (Fig. 4). One stack comprises 13 battery modules, with 14 cells in each module. DC switches are included for isolating the battery system from the DC side capacitors at minor contingencies but still keeping the VSC in operation, thereby maintaining reactive power control.



Fig. 4: Li-ion battery cubicles.



Fig. 5: Control system and DC voltage distribution

Control system

The ESS plant is managed by ABB's MACH 2 control system, which is a system of both hardware and software, specifically developed for power applications. MACH 2 is built around an industrial PC with add-in boards and I/O racks connected through standard types of field bus (Fig. 5).

The ESS can be controlled from an Operator Work Station (OWS) located in the control system enclosure. An alternative possibility for control could be via Web Based Support (WBS).

The aim of the control is to

- Provide voltage/reactive power control at the 11 kV bus
- Transfer energy accumulated in the battery system to the 11 kV network
- Re-charge the battery system by temporarily drawing active power from the 11 kV network.

The ESS plant can operate in an automatic mode where local voltage measurements are used to determine the required injection of reactive power to stabilise the voltage at the ESS. In order to make decisions on ESS control from a wider range of measurements taken from across the network, such measurements would be collected and processed by algorithms on a central control system. Decisions would then be issued as ESS set points for active and reactive power control.

Main technical data

System voltage	11 kV
Reactive power range	600 kvar inductive to 725 kvar capacitive
Energy storage capability	200 kWh
Active power capability	200 kW during an hour; 600 kW during a few minutes
VSC	Rated at 850 kVA; 3-level, neutral point clamped type converter; IGBT based, pulse-width modulated
Type of battery	Li-ion

For more information please contact:

ABB AB

FACTS

SE-721 64 Västerås, SWEDEN

Phone: +46 (0)21 32 50 00

Fax: +46 (0)21 32 48 10

www.abb.com