

# Challenges with Multi-Terminal UHVDC Transmissions

Victor F. Lescale, *Member, IEEE*, Abhay Kumar, Lars-Erik Juhlin, *Member, IEEE*,  
Hans Björklund, *Senior Member, IEEE*, and Krister Nyberg

**Abstract**--The paper gives an overview of the operations aspects of parallel operation of HVDC converters, especially in multi-terminal schemes where the converters are located in different locations. For UHVDC schemes,  $\pm 800$  kV or even higher the geographic distances between the stations can be very significant. Considering the high power rating of UHVDC transmissions, the reliability and availability aspects are considered during all stages of development and design. Thus, the consequences of any outage have to be minimized. It is important that faulty equipment is quickly and safely isolated from the remaining transmission system.

In a multi-terminal transmission system the telecommunication is important for coordination of current order and maneuvers in the different stations even if there are back-up controls for not losing the power transmission in case of telecommunication failures. The control and protection systems for a multi-terminal UHVDC transmission are conceptually described.

**Index Terms**--HVDC Transmission, Multi-Terminal, Operation Performance, Stresses, UHVDC.

## I. INTRODUCTION

THIS document describes the challenges with multi-terminal Ultra High Voltage Direct Current (UHVDC) transmission systems. In theory, multi-terminal HVDC schemes can be arranged as converters in the different stations connected in series or in parallel. The various concepts for multi-terminal HVDC transmission can be found in the literature [1]-[6]. A bibliography of papers presenting multi-terminal HVDC up to 1979 can be found in [4]. However, in practice only the concept with parallel converters has been used as it offers much more flexibility and lower overall transmission losses. Consequently the first part of the paper presents the basic principles for operation of converters in parallel in various configurations. The simplest configuration is when the parallel converters are located in the same station. The most challenging configuration is when a small inverter is connected to an HVDC transmission line with main converters of significantly higher rating.

V. F. Lescale (e-mail: [victor.lescale@se.abb.com](mailto:victor.lescale@se.abb.com)), A. Kumar (e-mail: [abhay.kumar@se.abb.com](mailto:abhay.kumar@se.abb.com)), L.-E. Juhlin (e-mail: [lars-erik.juhlin@se.abb.com](mailto:lars-erik.juhlin@se.abb.com)), H. Björklund (e-mail: [hans.bjorklund@se.abb.com](mailto:hans.bjorklund@se.abb.com)) and K. Nyberg (e-mail: [krister.nyberg@se.abb.com](mailto:krister.nyberg@se.abb.com)) are with the HVDC department of ABB AB, SE-771 80 Ludvika, Sweden.

978-1-4244-1762-9/08/\$25.00 ©2008 IEEE

The next chapter deals with paralleling and de-paralleling of converter to a running HVDC transmission. Especially, the requirement on switches for isolation of a converter from a live system is analyzed, both at normal, planned, outage of a converter and at protective isolation of a faulty converter. There are some alternatives with their pros and cons.

Further on the basics for the control and protection systems for multi-terminal UHVDC schemes are outlined. Important aspect is current sharing during transients, at disturbances and during the restoration process after outage of converters or line sections. Also the possibilities for modulation of active and reactive power are treated. Especially the procedures for dealing with dc line faults are presented.

The last chapter deals with other aspects of special importance for multi-terminal HVDC such as the time delay between the stations due to the long lines. This is relevant both for the telecommunication delay and the traveling time for the current and voltage waves on the dc line at fault and disturbances. Also specific stresses on equipment due to the multi-terminal configuration are discussed.

## II. PARALLEL OPERATION ASPECTS

In parallel operation all parallel converters are connected to the same line. Thus, the dc line voltage is a common parameter for the parallel converters. Only the voltage drop due to the dc line load current gives a difference. This is true both during steady state and during transient conditions. All parallel converters are provided with voltage and current control [2]. However, as there only is one dc line voltage, only one converter, often the largest inverter controls the dc voltage while the other converters control their own dc current. There are variations depending on the configuration, especially how to treat the transient current sharing at disturbances and faults.

### A. Normal steady state operation

Fig. 1 shows a basic multi-terminal scheme with two rectifiers (R1 and R2) and two inverters (I1 and I2) connected to the same dc line with voltage  $U_d$ .

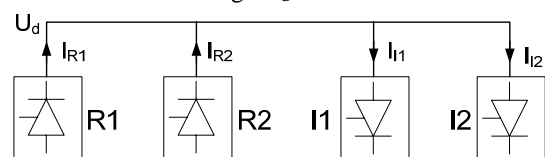

Fig. 1. Multi-terminal HVDC system with two rectifiers and two inverters.

Fig. 2 shows the generally used basic voltage-current (U-I)

characteristics for the four converters. The small circles at the crossings of the voltage  $U_{d1}$  with the U-I characteristics show the steady state operating points for the four converters. The figure is simplified as dc line voltage drops between the stations are disregarded. Neither the modification due to the Voltage Dependent Current Order Limiter (VDCOL) is shown. It is assumed that the inverter I2 is controlling the voltage to  $U_{d1}$  while the other inverter is controlling its current. For being able to control its current inverter I1 must have a certain margin between its voltage limitation due to the minimum extinction angle  $\gamma$  and the dc voltage  $U_{d1}$  defined by inverter I2. The thinner line in the characteristic of inverter I2 indicates that it dynamically can increase its voltage by temporary reduction of the margin angle  $\gamma$  below the steady state limit. This facilitates performance at small disturbances. The sum of the current orders in the inverters is somewhat lower than the sum of the current orders of the rectifiers. This is the current margin shown as the margin  $I_m$  in Fig. 2.

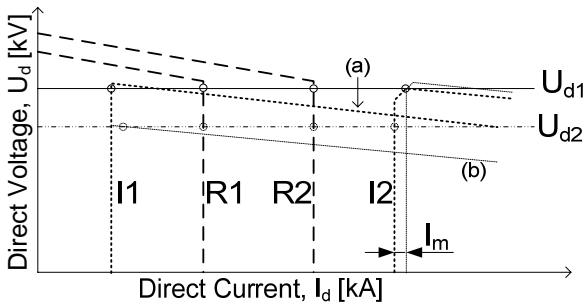

Fig. 2. Voltage - Current characteristics for the parallel converters in Fig. 1.

The size of the current margin is in order of ten percent of the rated current of one converter. The current margin is important at disturbances. For a certain (temporary) reduction of the ac voltage of the ac network feeding inverter I1 the characteristic of I1 is reduced from the line marked (a) in Fig. 2 to the line marked (b). As a consequence the dc voltage will be reduced to  $U_{d2}$  controlled by inverter I1. The new operating points are shown as dotted circles where the  $U_{d2}$  line crosses the converter characteristics. The important point is that the current control in the rectifiers and inverter I2 will limit the current in inverter I1 to its order plus the current margin.

### B. Parallel converters in the same station

Operation of parallel converters is significantly simplified if the parallel converters are located in the same stations. The coordination and balancing between the parallel converters can always be assured as no telecommunication is needed. The parallel inverters may both operate in voltage control as they are located in the same station connected to the same ac system. The only challenge is to secure continued operation without risk for overload if one parallel rectifier or inverter is lost when the telecommunication is out of service.

There are a number of schemes around the world where converters in the same station are operating in parallel, often as a back-up mode of operation, but also as the normal mode of operation.

### C. Multi-terminal schemes, all converters with similar rating

When the parallel inverters and/or the parallel rectifiers are located in different stations there is an increased need for co-ordination via telecommunication. Furthermore, only one inverter can operate in voltage control while all other converters are operated in current control as discussed in II.A above.

Besides the normal coordination of current order between the terminals, the telecommunication is needed for: proper timing of the action in the rectifiers at dc line faults, identification of a faulty dc line section, ordering and coordination of actions for clearing faults in converters or line sections, restoration of the power transmission, as far as possible, after an outage of converters or dc line sections.

There must be back-up functions for power restoration and for preventing overload of equipment in the case that the telecommunication is out of service. In such a case a reduced level of performance on longer restart time has to be accepted.

The three terminal HVDC transmission between Québec and New England has been in operation since 1992 [7]-[10].

### D. Tapping with a small inverter

The increased challenges with a small tapping (inverter) connected to a line pole with converters of much larger rating is due to three conditions: a) The current margin is in the same order, as the rating of the tapping. b) A disturbance in the small network connected to the small tapping also impacts the power transfer between the main converters. c) The risk that equipment in the tapping stations is damaged by overcurrent.

The measures for dealing with a) and b) is to ensure that the tapping always operates in current control even at small voltage variations in the connected ac network leading to an increased commutation margin angle in steady state. In addition the connected ac network may be strengthened by an SVC or a synchronous condenser.

The measure for preventing damage due to overcurrent may be a full size HVDC breaker or a fast by-pass-switch, combined with a high-speed isolation switch.

Tapping is most easy to connect to an HVDC transmission with unidirectional power flow. Anyhow, switching arrangement for reversing the polarity of the tapping converter may be needed for meeting the availability criteria. Furthermore, fast and reliable telecommunication significantly facilitates the operation of a small tapping inverter. The Corsican tapping has been in operation since 1987 [11].

It can be commented that adding a small rectifier to multi-terminal HVDC system is very straightforward.

### E. Schemes with more than two inverters and/or rectifiers

When the number of parallel inverters and rectifiers increases, the complexity of the master control that is responsible for coordination between the terminals increases very significantly. Furthermore, the required stiffness of the ac network connected to the inverter which is controlling the dc voltage also increases as the short circuit ratio not only depends on the rating of that converter but also the total rating of the transmission system. In addition the current margin must be increased considering the tolerances in many parallel con-

verters. In extreme, each inverter will see the same condition as a small inverter tapping, discussed in II.D above. If the number of parallel inverters increases the real challenge would be to obtain acceptable recovery at commutation failures caused of disturbances in any of the connected ac networks, unless the short circuit power of the ac networks are in order of twice the total rating of the multi-terminal HVDC transmission.

### III. PARALLELING AND DE-PARALLELING

The terms “paralleling” and “de-paralleling” can have two somewhat different meanings. The simplest form of paralleling and de-paralleling is the automatic paralleling initiated from the power control depending upon the pole line current order.

The more complex procedures are the paralleling sequence for taking a converter into parallel operation after an outage and the corresponding de-paralleling sequence for taking a converter out of operation.

#### A. Paralleling

Paralleling of a converter, previously being out of service, is always performed as an operator initiated event. As preparation for paralleling the converter will be connected to the neutral; then, it will then be energized, followed by connection to the DC line. After connection, the tap changer is adjusted to about the same position as the parallel converter already in operation. Also the needed margin is considered as the new converter always starts operation in the current control mode, regardless if it is operating as inverter or rectifier.

When the current order is increased above twice the minimum current for a converter pole (plus hysteresis margin) the converter pole can be automatically paralleled, which means that the converter will be forced to full inverter operation followed by de-blocking of the valves.

After de-blocking the converter, the current control brings the now paralleled converter into “normal” operation and the master control adjusts the current orders as appropriate for the proper sharing between the parallel converters.

#### B. Normal de-paralleling

Normal de-paralleling for taking a converter out of operation is an operator initiated event. During parallel operation, the total current order of the line pole is reduced below twice the minimum current for one converter, then one of the parallel converters will automatically be de-paralleled. Alternatively, the master controls balance the current orders for the converter to be de-paralleled. The tap changer control ensures that there is a sufficient margin in  $U_{di0}$  ensuring that the converter is operating in the current control mode. This means, its current order will be reduced to zero, and it will be forced to full inverter operation for extinction of the dc current followed by blocking of the converter valves. However, there will be no switching action and the converter pole will remain in Ready condition for automatic paralleling again, or it can be isolated.

#### C. Protective de-paralleling

The principle for protective de-paralleling is the same as for operator initiated de-paralleling, but the event is more abrupt. The control angles in the faulty converter poles are immediately ordered to full inverter operation for extinguishing the dc current and the valves are blocked. (The master controls adjust the currents order as a second step.) After blocking the pole, the high speed switch disconnects the converter and the dc side disconnectors are opened. If the converter ac side breaker is tripped or not depends on the type of faults.

For some types of faults such as inverter dc side earth faults, it can not be assured that blocking of the valves will extinguish the dc current. For these types of rare faults the valves will be blocked with an order of a by-pass-pair in the faulty inverter, the rectifiers connected to the dc line pole will be temporary ordered to full inverter operation, as at a dc line fault. That will extinguish the dc current during the time needed for opening of the dc pole high speed switch before restarting the transmission.

The corresponding faults in a rectifier will normally not result in a by-pass-pair in the faulty rectifier. Anyhow, the other rectifier(s) will temporary be forced to full inverter operation for facilitating the isolation of the faulty rectifier.

#### D. Disconnection of a faulty dc line section

Depending upon the topology of the multi-terminal HVDC transmission scheme, it may be possible to isolate a line section and still operate the remaining converters. In a healthy section, there shall be at least one rectifier and one inverter. Of course, necessary transducers and other detection and switching/isolating devices would be needed to identify the specific dc line section(s) which can be disconnected, preferably after a pre-set number of restart attempts.

#### E. Isolation by switches without dc current breaking capability

There are several possible ways to isolate either converters or lines. One of them is to use simple isolators for this task. Isolators however present a difficulty: in a manoeuvre it will take a significant number of seconds for the device to be able to take current (when closing), or voltage (when opening); especially so for UHVDC. If the maneuver is part of a sequence requiring curtailments, such delay will not be acceptable, and a different device has to be considered.

A high speed switch (HSS) can be used. A high speed switch is, in reality, a somewhat modified breaker, but it is not called upon to break any current. Such device will achieve full current or full voltage capabilities within very short times, far less than 150ms.

A word of caution to the reader: the time mentioned is not the time necessary for a complete sequence. A complete sequence will require that the current through the HSS is brought to zero by the system before opening can be ordered.

An HSS applied in UHVDC will consist of several chambers, and will therefore require some form of voltage grading among them. The grading cannot be achieved by capacitors

alone, as done in ac breakers; dc grading will be required, especially in areas with pollution that can cause significant leakage currents in the columns.

In most applications foreseen, the isolation function is expected to be done with a combination of both devices in series: an HSS to perform the quick isolation or quick connection during maneuvering, in series with an isolator for removing the permanent dc voltage stresses from the chambers in the HSS for permanent operation in open position. This will also eliminate the possible transient stresses that may come from the system.

#### F. Isolation by using HVDC breakers

In some cases, it can be tempting to perform the isolation without waiting for the current to be brought down to zero by other means, especially for faults. In that case, the device needed would be a full fledged HVDC breaker. Before seriously considering an HVDC breaker, one should carefully weigh its advantages and disadvantages.

Being able to quickly isolate a fault has two main aspects. One of them is the transmission system behavior. The other one is the stresses on a faulty converter. The perceived system advantage of being able to quickly isolate a fault will be diluted by the time needed for the transmission system to anyway come to a new operating point. The total time gained may not be that much for a system. For a weak inverter however, the gain in time necessary for isolating it to reduce stresses during faults may be very valuable.

One obvious disadvantage of an HVDC breaker is the investment cost: an HVDC breaker will have an HSS as a component, usually called “interrupter” in this application, but in addition, it will need a rather large platform with capacitors and arrester-like non-linear resistors, both with high energy capability requirements, and at a cost far above that of the interrupter.

A not so obvious disadvantage is that the insulation levels will most likely need to be higher than they would otherwise be. The reason is that an HVDC breaker does not wait for a current zero: it has to create the zero. To do that, it will inject a very high counter-voltage in the circuit. The voltage has to be high enough to counteract the sources, and be well above that. It is only the remainder above the sources that will act upon the inductances in the circuit and cause the current to diminish. If the remainder is too small, the interruption will take too long time, and the energies in the non-linear resistors will be impractically large.

Considering that in an UHVDC system the insulation levels are already very high, every effort has to be made to hold them down, and any attempt to increase them has to be carefully analyzed.

### IV. CONTROL AND PROTECTION

#### A. Basic current and voltage control

In the literature many different types of current and voltage control principles have been suggested to be used for multi

terminal HVDC systems.

In real installations only one type has been used, however, and that is an adaptation of the well known current margin control principle used for two terminal installations [7]. This means that one station controls the voltage and the others operate in current control as described in the section on steady state operation. During system dynamic conditions the roles may change and therefore all converters are equipped with both current and voltage controllers and in the voltage controlling terminal a current margin is subtracted from the current order.

#### B. Control of current sharing

In a two terminal HVDC scheme only one terminal will determine the current and therefore there are very little requirements to distribute current orders. The current order is anyway sent also to the voltage controlling terminal, but as the current margin is subtracted the current order in that terminal will only be active during transient or dynamic disturbances.

In a multi-terminal system there may be more than one converter that simultaneously control the current and therefore a central master control function is needed that calculates and distributes a current order to each converter so that the basic condition that the sum of all current orders (with signs) is always zero.

$$\sum I_{on} = 0$$

There are many ways to accomplish this, but the most successful is to take the desired current order for each terminal and modify this order to satisfy the above criterion. There may also be different kinds of current limitations for each converter that does not allow it to carry the desired current and this must also be taken into account when calculating the adjusted current order. An example of such a current order calculation function for the example multi terminal system with two rectifiers and two inverters, as described earlier, is shown in figure 3.

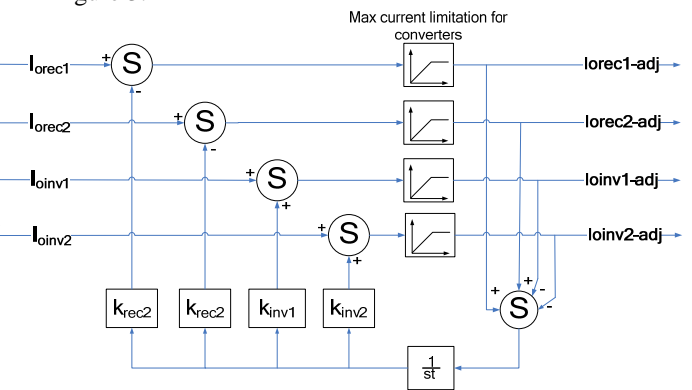

Fig. 3. Block diagram for a four terminal current order calculation.

The different distribution factors  $k$  are used to determine how a current order unbalance are redistributed among the different terminals.

### C. Power modulation

An HVDC transmission has the advantage, compared to an AC transmission system, that the power can be very accurately controlled at all times. This can be used to modulate the power to stabilize parts of the surrounding AC system. One typical such application is to modulate the DC power based on a frequency measurement to stabilize a connected generator station.

This is of course also possible to implement in a multi terminal HVDC installation, if only the balance requirement described above is fulfilled. It is also possible to apply modulation to several converters simultaneously, for example the two rectifiers in the above example, as long as the other terminals have the current capability to facilitate the current order request.

The control function in figure 3 will automatically handle also such modulation signals and will distribute and limit them appropriately when required.

### D. Detection and clearance of converter faults

With a modern fast telecommunication, faults in converters are handled by the master controller and appropriate sequencing logic, as described in the de-paralleling section above, and also involves changing the individual VDCOL (Voltage Dependent Current Order Limiter) settings dynamically during fault situations. In this way a very good performance during faults and in the redistribution of power after faults can be achieved. Of course there can be complications after permanent converter faults when the power needs to be redistributed, especially when there are ground current restrictions in place, but the central master controller can be designed to establish the best possible compromise very quickly.

In the very rare case when telecommunication is totally out of service, a well designed multi terminal HVDC system will use special VDCOL characteristics to detect faults in remote nodes and apply the necessary de-paralleling sequences.

### E. Detection and clearance of dc line faults

The same type of dc line fault protections as used in a two terminal system, with voltage level and derivative detectors, can be used also for a multi terminal HVDC system. The difference is that a dc line protection is installed in all terminals even those dedicated as inverters. For all intermediate terminals there are also arrangements to detect the fault current direction to make it possible to determine the faulty line section, if there is a permanent line fault that can be disconnected.

After a line fault is detected all rectifiers need to be simultaneously retarded to bring the current to zero and at the restart the possible reconfiguration of the network must be taken into consideration by the master control.

For the situation when all telecommunication is lost special local restart sequences and VDCOL settings are used to separate a line fault from a converter fault.

## V. OTHER ASPECTS OF SPECIAL IMPORTANCE

### A. Reliability

Due to the large amount of power transmitted by multi-terminal UHVDC transmissions reliability is the most important challenge. This concern both the traditional reliability and availability related to outages as to transient reliability related to performance during and recovery after temporary faults and disturbances. A base for the good reliability is a good reliability for all involved equipment with a proper and good strategy for redundancy and supervision of control and measurement systems. Furthermore, for large and complex systems a throughout failure mode effect analysis is needed for identify and redeem common mode failures which may affect more than one converter unit[12]. In this aspect it must be remembered that the ac system is common for all converters in at least one terminal. Thus, an appropriate coordination between the ac side and dc side protections is very essential. The auxiliary power supply may also be common for more than one converter.

Regarding transient reliability, fast detection and isolation of faulty equipment are very essential. It is also important that the fault clearance actions do not trip more equipment than absolutely necessary. This is also valid for isolation of the faulty dc line section in case of a persistent dc line fault. Utilization of overload capability of the remaining equipment reduces the consequences at an outage. However, it must be assured that there is no increased risk for outage of additional equipment.

Regarding availability it is important that all maintenance can be performed with absolutely minimum of outage of converters and/or lines.

### B. Additional stress due to Multi-Terminal Operation

The most significant additional stress due to multi-terminal is the increased transient and temporary overcurrent in the inverters at any type of disturbances and faults as all parallel converters contribute to the current overshoot.

In the case that faults in a multi-terminal network is cleared by full size HVDC breakers switching type overvoltages is introduced into the dc system.

### C. Line Length

Primarily, the length of the line affects the exposure for various weather conditions, e.g. lightning storms and fog. It also impacts its exposure for other external conditions such as bush fires. However, super low frequency induced voltage due to geomagnetic storms do not impact dc lines as the induced voltage is negligible compared with the converter voltages.

The large length for UHVDC has also an effect on the travel time between the terminals both for main circuit transients and telecommunication signals. The electric wave traveling speed in an overhead line is close to the speed of light. The speed of light in an optic fiber is not faster than the speed of light divided by 1.5. This means that it takes 3.3 ms before the rectifier see the effect of a fault in the inverter if the line

has a length of 1000 km and it takes 6.6 ms until the inverter see any response from the rectifier, in addition to the rectifier response time. During this 6.6 ms the inverter only see the surge impedance of the line of around 300  $\Omega$ . The corresponding surge current is 2.7 kA at a dc line voltage of 800 kV.

The additional response time due to the wave traveling time in the optic fibers is 5 ms. Thus the additional time delay of the response from the other station is 10 ms. This time delay may have minor impact on the restoration of the system after a disturbance, but it has to be considered during the design for not having a number of series connected questions-answers between the terminals. Furthermore, this time delay is very important at design of the regulators for any type of damping regulators.

#### D. Importance of Telecommunication

With a number of terminals and/or converters operating in parallel the importance of the telecommunication for coordination of the multi-terminal UHVDC system increases. The reason is the number of possible configurations in operation after a disturbance or an outage. Even if the equipment is protected against damages lack of coordination and inter-terminal actions may lead to prolonged disturbances or loss of all converters connected to the same pole line. This is especially critical at loss of one parallel inverter during high load, as the pre-fault dc current from the rectifiers will be too high for the remaining inverter(s).

In practice it is not possible to change the load without telecommunication. Even manual change of the load flow requires communication between the operators.

#### E. Electric and magnetic field

Considering the environmental impact neither the electrical field nor the magnetic fields from the UHVDC lines are considered to be of concern as the limit increases with decreased frequency [13].

Anyhow, with the high voltage and high current it is important to keep the electromagnetic fields within control. For avoiding corona from the pole conductors, the bundle has a large diameter with many conductors. This minimizes the amount of corona from the dc line as the E-field around the pole conductors will be quite low. However, if not considering the E-field at the steel structures of the towers and the shield wires, the corona phenomena might occur on those structures instead due to the much smaller radii of the earthed structures. The field levels for various structures may change with the mode of operation, i.e. bipolar or mono-polar operations. It must be noted that when the other line is left free floating in mono-polar operation it will be charged to the same polarity as the pole line in operation, but with a lower voltage due to charging from the pole line in operation.

### VI. CONCLUSIONS

Parallel operation of converters is well established within the HVDC industry. A few multi-terminal schemes have been in successful operation in more than 15 years. The now avail-

able wide band fiber-optic links for telecommunication facilitates operation of multi-terminal schemes. Therefore, an increased number of multi-terminal HVDC schemes is anticipated. However, with the present state of the art, development of large terminal HVDC networks with many terminals is unlikely due to the spread out of disturbances.

The actual hardware for isolating parts of an UHVDC transmission system are looked upon, and the use of combined isolators with HSS's is perceived as being the most convenient one. HVDC breakers are also looked upon, but not recommended.

### VII. REFERENCES

- [1] K.W. Kanngiesser, J.P. Bowles, Å. Ekström, J. Reeve, E. Rumpf, "HVDC multiterminal systems", A paper presented in the name of Cigré SC 14. Cigré paper 14-08, 1974 Session.
- [2] Å. Ekström, L.-E. Juhlin, G. Liss, "Parallel connection of converters for HVDC transmissions" *IEEE Trans. Power Apparatus and Systems*, Vol. PAS-97, no. 3, pp. 714-724, May/June 1978.
- [3] L. Bergström, L.-E. Juhlin, G. Liss, S. Svensson, "Simulator study of multiterminal HVDC system performance" *IEEE Trans. Power Apparatus and Systems*, Vol. PAS-97, no. 6, pp. 2057-2066, Nov/Dec 1978.
- [4] J. Reeve, "Multiterminal HVDC power systems", *IEEE Trans. Power Apparatus and Systems*, Vol. PAS-99, no. 2, pp. 729-737, Mar/Apr 1980.
- [5] F. Nozari, C.E. Grund, R.L. Haut, "Current order coordination in multiterminal DC systems", *IEEE Trans. Power Apparatus and Systems*, Vol. PAS-100, no. 11, pp. 4628-4635, Nov 1981.
- [6] R.L. Hauth, F. Nozari, G.D. Breuer, D.J. Melvold "Multi-terminal HVDC control techniques for future integrated AC-DC networks" Cigré paper 14-01, 1982 Session.
- [7] M. Hegi, M. Bahrman, G. Scott, G. Liss, "Control of the Québec- New England multiterminal HVDC System", Cigré paper 14-04, 1988 Session.
- [8] D. McCallum, G. Moreau, J. Primeau, D. Soulier, M. Bahrman, B. Ekehov, "Multiterminal integration of the Nicolet converter station into the Québec-New England Phase II HVDC transmission system", Cigré 1994, paper 14-103.
- [9] G.L. Désilets, J Primeau, G Moreau, "Québec/New England multiterminal HVDC network commissioning", Paper 2.4, Proc. Cigré SC 14 International Colloquium on HVDC and FACTS, Sep 18-19, 1995, Montréal, Canada.
- [10] Y. Allard, D. Soulier, J.J. Cochrane, B.D. Railing, "Multiterminal operation experience. Hydro-Québec/NEPOOL Phase II HVDC network", Paper 6.4, Proc. Cigré SC 14 International Colloquium on HVDC and FACTS, Sep 18-19, 1995, Montréal, Canada.
- [11] V. Collet-Billon, J.P. Taisne, P. Charles, "The SACOI (Sardinai-Corsica-Italy) multiterminal link commissioning tests of the Corsican station Lucciana", Cigré paper 14-12, 1988 Session.
- [12] D Soulier, G.L. Désilets, J Primeau, S. Chano, L.-E. Juhlin, B. Ekehov "Investigation of bipole trip risk in an HVDC transmission scheme", Paper 1.1, Proc. Cigré SC 14 International Colloquium on HVDC and FACTS, Sep 18-19, 1995, Montréal, Canada.
- [13] Directive 2004/40/EC of the European parliament and of the council of 29 April 2004 on the minimum health and safety requirements regarding exposure of workers to the risks arising from physical agents (electromagnetic fields).
- [14] 5-6, 2007.

## VIII. BIOGRAPHIES



**Abhay Kumar** was born in Delhi, India in 1961. He obtained his degree in Electrical Engineering from University of Roorkee (now IIT Roorkee) in 1982. He joined NTPC Ltd. in 1982 and worked until 1995 as Deputy Chief Design Engineer. He has been involved in the design of Vindhyachal B2B HVDC and Rihand – Delhi HVDC Projects and many other EHV substations. He has also been consulting engineer for Chandrapur – Padghe HVDC Project. From 1995 to 2000 he worked for ABB Ltd. New Delhi as Senior Manager at Power System Engineering and Business Development department. Since May 2000, he has been working for ABB HVDC in Sweden first as the Technical Manager for The Three Gorges – Changzhou  $\pm 500$  kV DC Transmission Project and presently as the Lead Engineer cum Project Manager for The Three Gorges - Shanghai  $\pm 500$  kV DC Transmission Project in Sweden.



**Hans Björklund** was born in Ludvika, Sweden in 1950. He obtained a Masters degree in Electrical Engineering from the Royal Institute of Technology in Stockholm Sweden in 1974. The same year he joined the ASEA HVDC group in Ludvika Sweden and worked with design and test of the control systems for the Inga Shaba, Skagerrak, and CU HVDC projects. In this period he also developed the basic theories for sub-synchronous interaction between HVDC converters and turbo generators and developed the methods to damp such interactions. 1978-82 he was managing the design and testing of the master control systems for the Itaipu HVDC system. 1982-86 he was manager for the control system design, testing and commissioning of the Intermountain Power Project in the US. In 1986 he returned to Sweden and was manager for the HVDC control system development group and was involved in the control design for the multi terminal HQ-NEH HVDC project and the New Zealand Hybrid HVDC scheme with its unique combination of Hg and thyristor valves involving continuous parallel operation. In 1994 he was appointed Company Senior Specialist for HVDC and FACTS control systems and has been responsible for the development of ABB's successful Mach 1 and Mach 2 control systems, and their large scale implementation in the Three Gorges – Changzhou, Three Gorges – Guangdong and Three Gorges Shanghai HVDC projects. He has also been supervising the very complex process of upgrading old control systems in the Sylmar, CU, Square Butte, Skagerrak 1,2 and Apollo projects.



**Victor F. Lescale** was born in Mexico City, Mexico in 1944. He graduated as an Electrical Engineer from the University of Mexico in 1966. He joined CFE, the Mexican federal electric utility in 1967, where he worked until 1983. On that year, he joined ASEA, and moved to Ludvika, Sweden. He has more than 40 years of engineering and managing experience, in, among other fields, protection relays and control, high and extra high voltage installation commissioning, power system planning, special projects, HVDC control, HVDC system design, and in engineering and management of international HVDC projects. He has been Technical manager of some, and Project manager of other. At present he is Senior Lead Engineer in ABB's HVDC Section.



**Lars-Erik Juhlin** was born in Örebro in Sweden 1942. He holds masters degrees in electrical engineering from the Royal Institute of Technology. Year 1969 he joined ASEA, now ABB HVDC division. His 40 years of HVDC system engineering experience includes main circuit design, EMC, control and protection. During years 1988 to 1992 he was technical manager for the New Zealand DC Hybrid project. His present position is Senior Specialist within ABB HVDC system design involved in major HVDC development projects. He is a member of IEEE and Cigré



**Krister Nyberg** was born in Borlänge, Sweden in 1948. He obtained a B.Sc. from Mälardalens Institute of Technology in 1987. He joined the ASEA HVDC group in Ludvika in 1973 and worked with design and test of the control system for Skagerrak and Inga Shaba. In 1977-78 he developed the Valve Base Electronic for the CU project and the thyristor monitoring system for the Sylmar test valve. 1980-81 he worked with improvement of the gate control unit and in 1982-83 with project engineering for the Gotland II project. He continued in 1984-87 with project engineering for the IPP, Highgate and Kontis-Skan 2 projects. From 1991-2000 he was manager for the HVDC control equipment Hardware and Software development. From 2000 he works as a Senior Specialist of Control and Protection systems at ABB's HVDC Section in Ludvika Sweden