

## The SVC Light at the Trierer Stahlwerk



In 2000, an SVC Light rated at 20 kV, 0-38 Mvar was supplied to Amprion GmbH by ABB and installed at Trierer Stahlwerk in Trier, a steel plant taking its electric power from the Amprion grid. The SVC Light was supplied on a turn-key base. The purpose of the installation is to safeguard adequate power quality in the feeding grid at all times in conjunction with the operation of the steel plant.

### Powerful flicker mitigation

The steel production of Trierer Stahlwerk is based on melting of scrap in an Electric Arc Furnace (EAF) rated at 25/30 MVA. The EAF constitutes a heavy and highly erratic load on the power grid feeding it. The result, unless properly remedied, will be disturbances spreading into the surrounding grid over the Point of Common Coupling (PCC) such as voltage fluctuations, harmonics and phase unbalance. Fast voltage fluctuations, causing lamp flicker for consumers located elsewhere in the grid, are particularly unpleasant in this respect.

As a remedy, the SVC Light performs the task of flicker mitigator, as well as harmonic filter and balancer of unsymmetrical loads between phases in the feeding grid. The flicker

reduction factor achieved in the present case amounts to approximately four, which safeguards an acceptable residual flicker level at the PCC.

As valuable by-products, the stabilization of the EAF voltage and the stabilization of the plant power factor at a high value offer the possibility of productivity increase as well as a decrease of the operating costs of the plant.

### State of the art converter and semiconductor technology

The main building blocks of SVC Light are a Voltage Source Converter (VSC), a DC voltage source, and a reactor interface connecting the SVC Light to the EAF bus. The VSC is of a three level design, rated in the tens of MVA range and using IGBTs (Insulated Gate Bipolar Transistor) as switching elements. The control scheme of the VSC utilizes Pulse Width Modulation (PWM) with a switching frequency in the kHz range. This enables the very fast converter response necessary to cope with flicker in an effective way.

The VSC is inherently a producer of inductive as well as capacitive reactive power. Since only capacitive reactive power is required in the given application, the operating range of the SVC Light is offset fully into the capacitive range by means of parallel harmonic filters of suitable rating (19 Mvar).

### High power rating

IGBTs of Presspack type are utilized, packaged in housings almost like conventional high power thyristors. Inside, IGBT chips and antiparallel diode chips are connected in parallel, with pressure contacts normally providing the electrical contact to the surroundings.

IGBTs allow series connection, thanks to low delay times for turn-on and turn-off. This enables SVC Light to be connected directly to voltages in the tens of kilovolts range. Thus, by series connecting of IGBTs, sufficient power rating is achieved without any need for paralleling of converters.

### Environmentally friendly design

The DC capacitors of the SVC Light are of a compact, high voltage dry type design, particularly suitable for the applica-

tion. By use of metallized film, insulated by means of polymers instead of impregnated materials, the capacitor gets a dry design, making it environmentally very friendly. In manufacturing, it requires neither impregnating fluids nor the use of paint solubles. It has high energy density, which together with its cylindrical shape enables very compact build-up of the DC capacitor bank of the SVC Light.

### Improved process performance

A considerable bus voltage improvement at the 20 kV furnace bus has been achieved by means of the SVC Light. Not only have the voltage fluctuations at the bus been greatly reduced, but an improvement of the bus voltage RMS value has been provided, as well. This means that a higher active power input is available into the arc furnace than in the uncompensated case, and hence, a more efficient melting procedure is enabled.

### SVC Light OFF

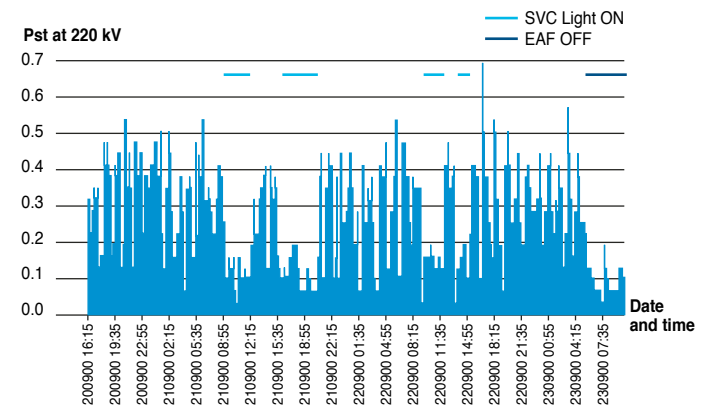
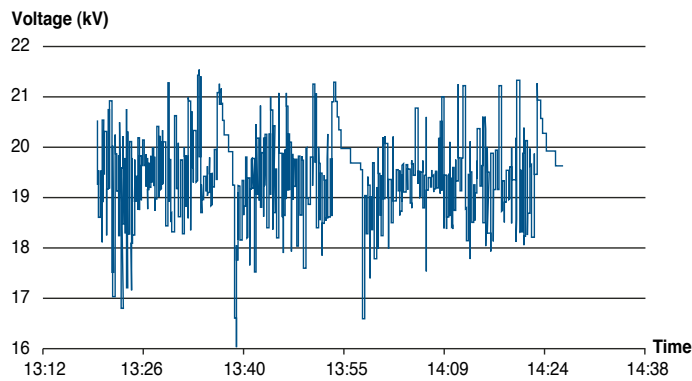

Flicker recordings at the 220 kV PCC with and without the SVC Light in operation.

### SVC Light ON

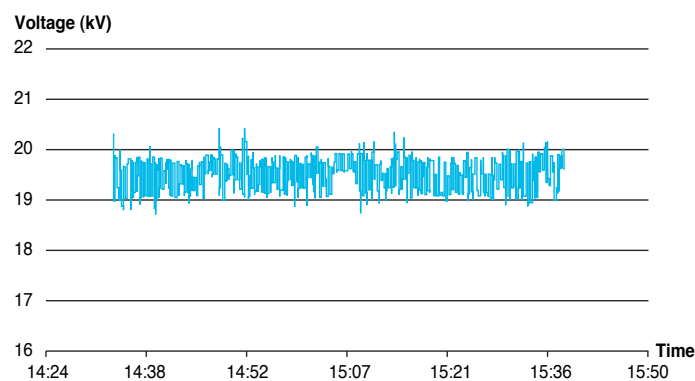

EAF bus voltage without and with SVC Light.

### Single-line diagram

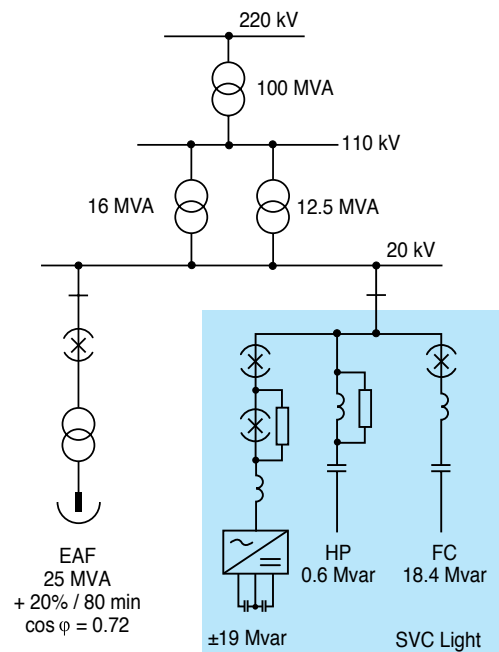

Since the active power input into the furnace is proportional to the square of the bus voltage, even a moderate bus voltage improvement will enable a sizeable rise in the available melting power, which, if desired, can be utilized for an increase of the annual output of the steel plant.

A bus voltage stabilized at a higher RMS value also enables a decrease of specific operational costs of the process, by means of lower specific electrode consumption, lower specific radiation losses, and less specific wear of furnace lining.

Furthermore, the stabilizing of the plant power factor at a high and constant value will enable a more favourable electricity billing for the furnace operator.

### Flicker reduction

Flicker measurements have been performed at the 220 kV PCC. An evaluation of the results of these measurements yields a flicker reduction factor due to the impact of the SVC Light around four.

#### Technical data

Rated furnace bus voltage	20 kV
Rated power, EAF	25/30 MVA
Dynamic range, SVC Light	0-38 Mvar (capacitive)
Control modes	Open-loop reactive power control; Closed-loop cos phi control
Flicker reduction factor	≈ 4
Flicker level at PCC with SVC Light in operation	Pst ≤ 0,74

### Layout

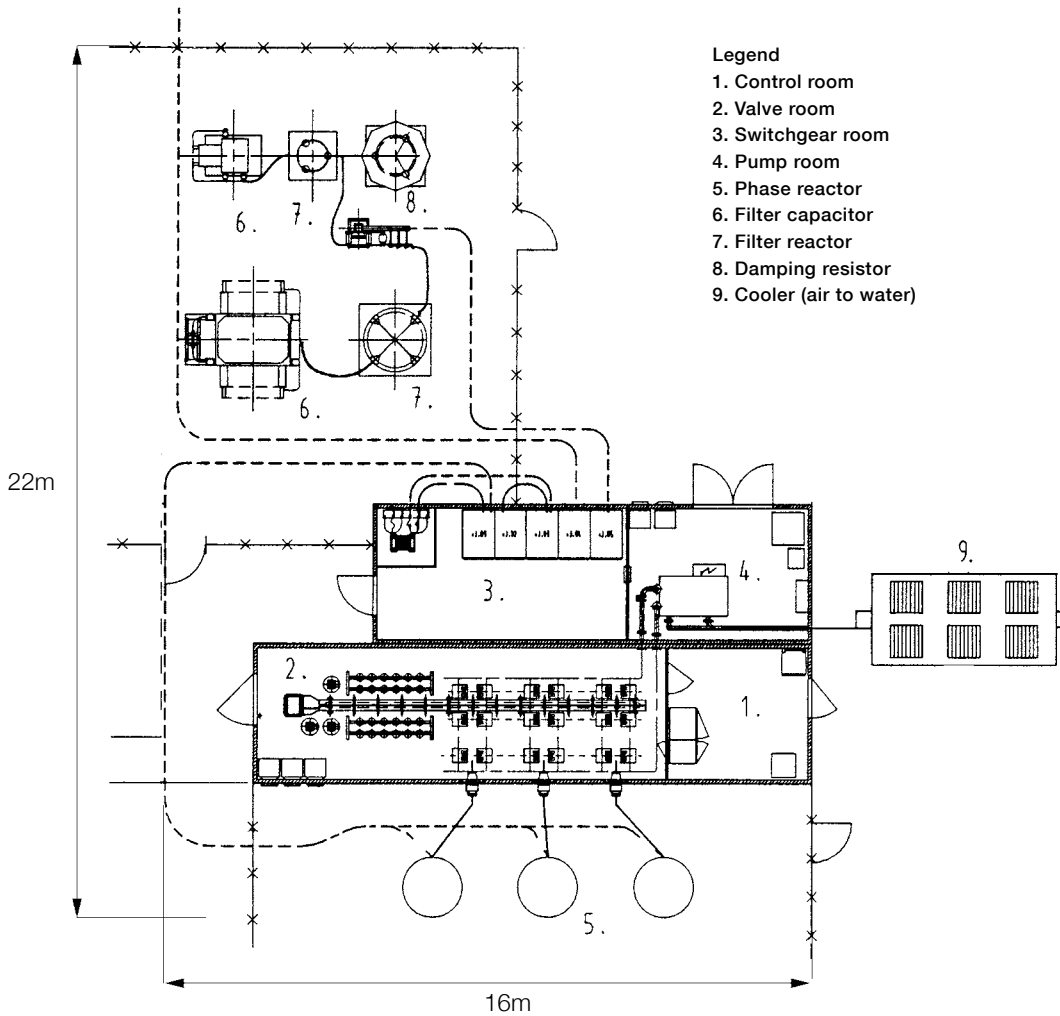

For more information please contact:

**ABB AB**

**FACTS**

SE-721 64 Västerås, Sweden

Phone: +46 21 32 50 00

Fax: +46 21 32 48 10

[www.abb.com/FACTS](http://www.abb.com/FACTS)