

ABB solutions for combined cycle power plants

ABB power generation

A reliable partner for comprehensive solutions

Experience of more than 40 years in power plant automation in more than 1200 turbine automation projects guarantees well proven and cost effective solutions

Know how of various turbine types / suppliers assures state of the art technology and high quality

Modular design of ABB-products allows

- Custom tailored technical concepts
- All sizes of applications and uniform solutions for all type of turbines
- Step by step replacement of installed equipment
- Most cost effective solutions for the customers

Facts about ABB in power generation

- Worldwide system business of more than 2,000 MUSD
- Worldwide product business in the same range
- Over 3,500 employees, mainly engineers
- More than 40 local/regional business units/centers worldwide
- Covering whole range of Instrumentation, Controls and Electrical systems for Power Generation („ICE“)
- Working relations with key players in the industry
- Strong local competence

ABB power generation

A reliable partner for comprehensive solutions

Large product portfolio allows smooth and transparent integration into overall plant DCS:

- Turbine control
- Unit control
- Electrical Systems
- Simulators
- Hydraulic systems

ABB power generation Control and electrical systems from ABB



Steam Power
Plants



Gasturbines /
CCPP



Waste-to-
Energy



Co-gen



Nuclear

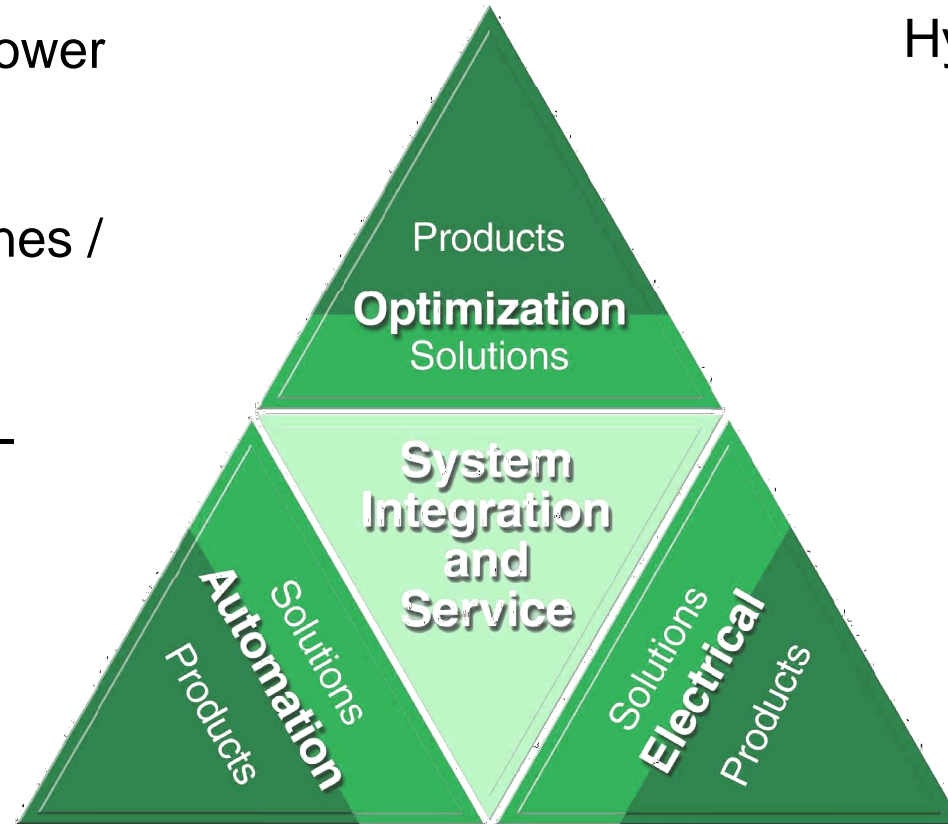

Hydro Plants



Wind



Solar



Desali-
nation



Diesel
Plants



ABB power generation Instrumentation, control and electrical systems (ICE)

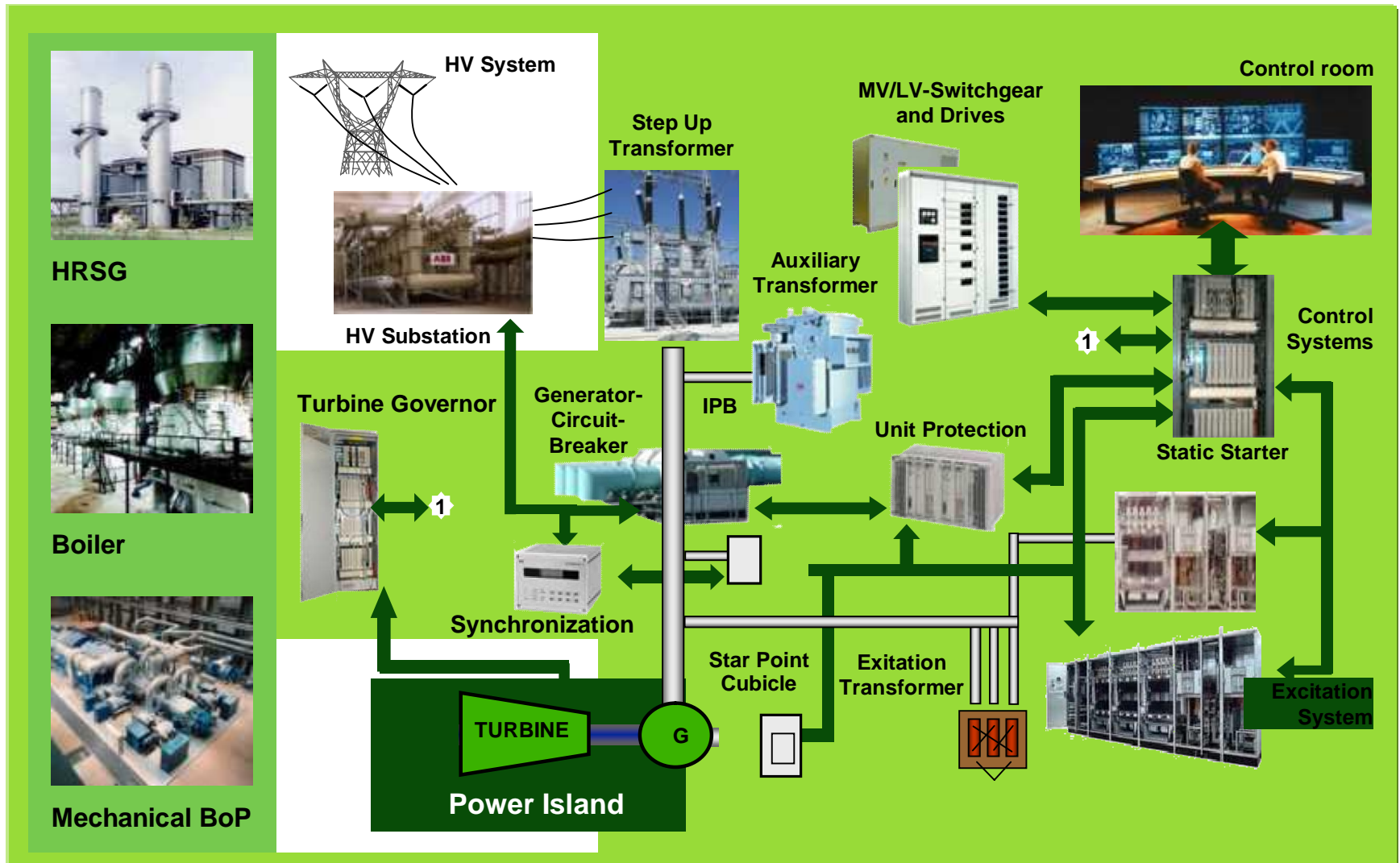

CCPP solutions

Plant life cycle support

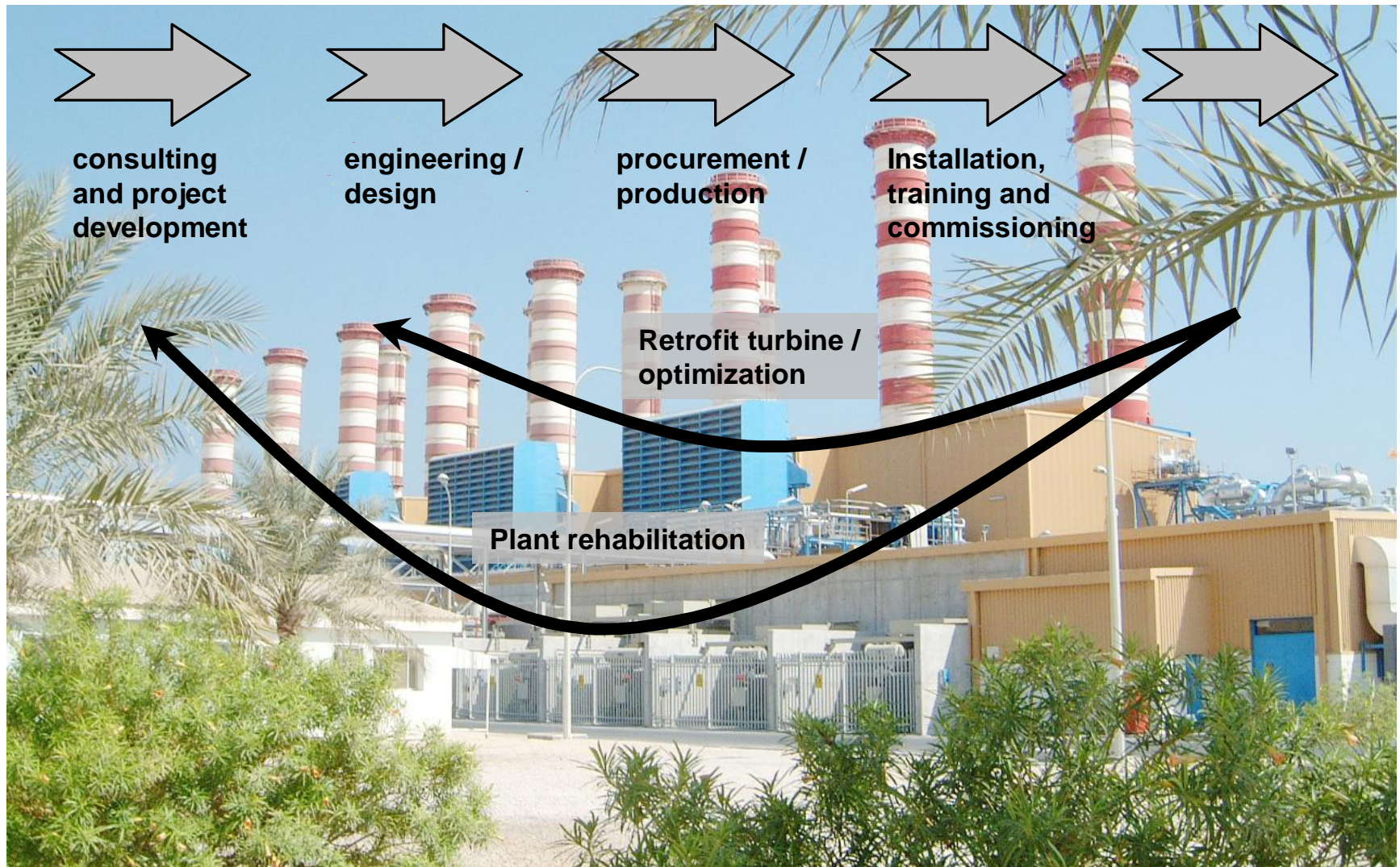

CCPP solutions

Project services for CCPP

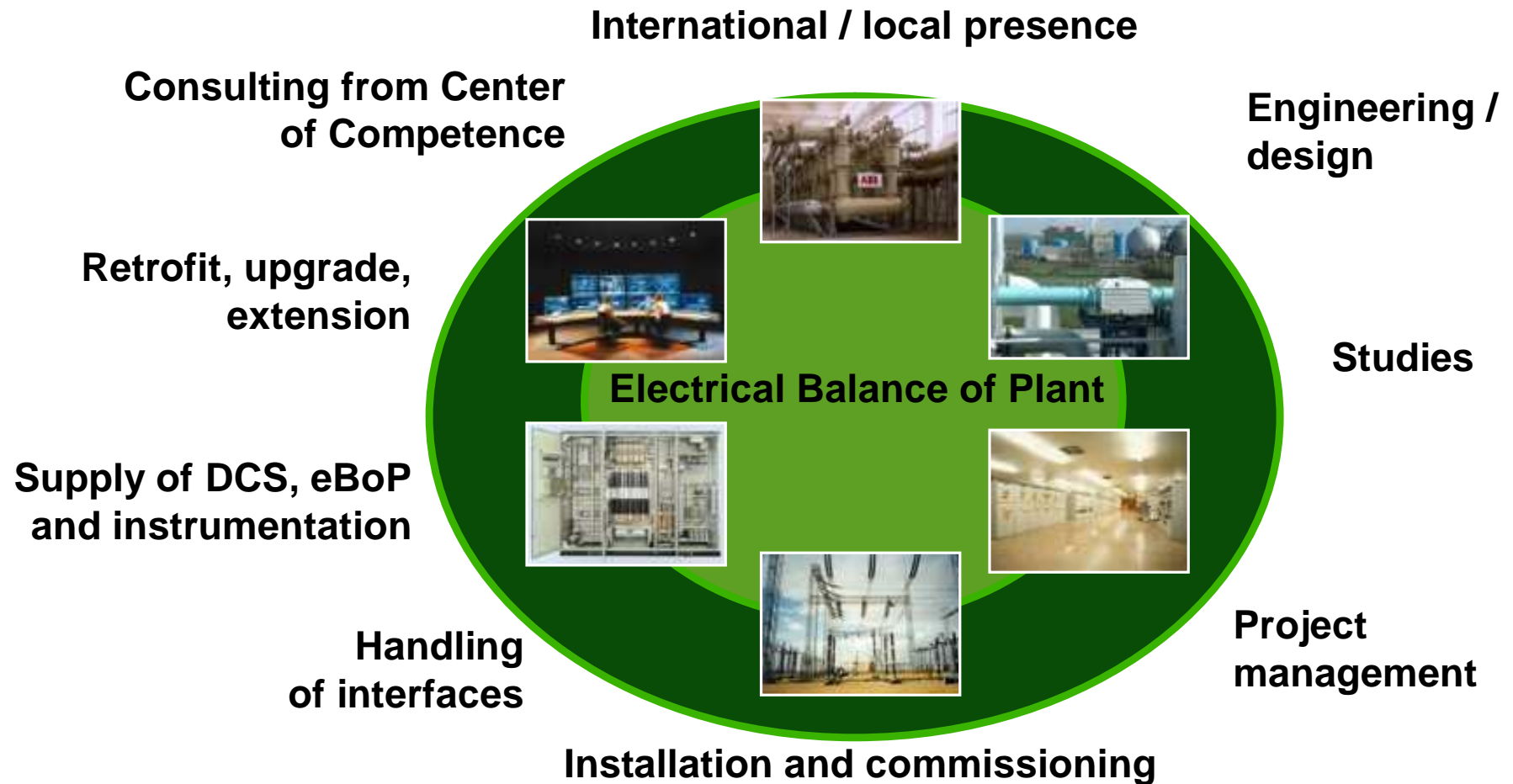

CCPP solutions

Consistent system design

Process knowledge is the prerequisite for optimal and consistent design of controls and electrical systems. (sizing of systems and seamless integration)
These systems prove to have a higher availability and a better energy efficiency.

Customer objectives, e.g.

- Availability
- Redundancy
- Performance
- Energy efficiency

P&I-Diagramm

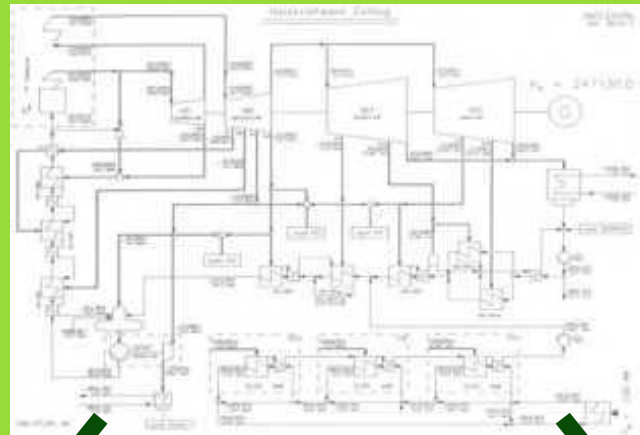

Operating criteria, e.g.

- Operating mode
- Component design
- Sizing and layout HV, MV, LV, transformers
- Duty cycle
- Plant maneuverability
- Load flow, voltage drop

DSC-configuration



Single line diagram

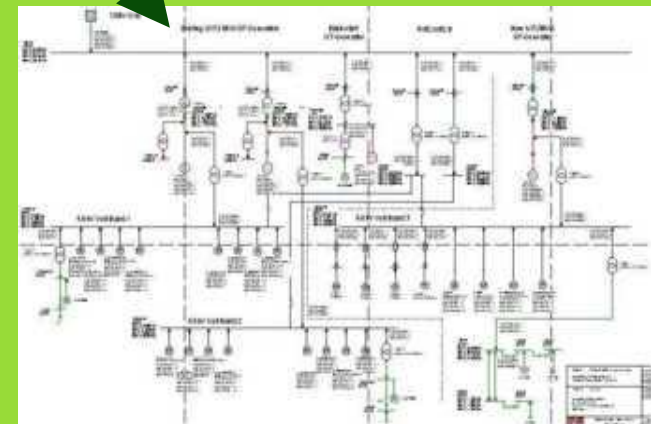

Optimized interface management

CCPP solutions

Excellence in electrical layout design

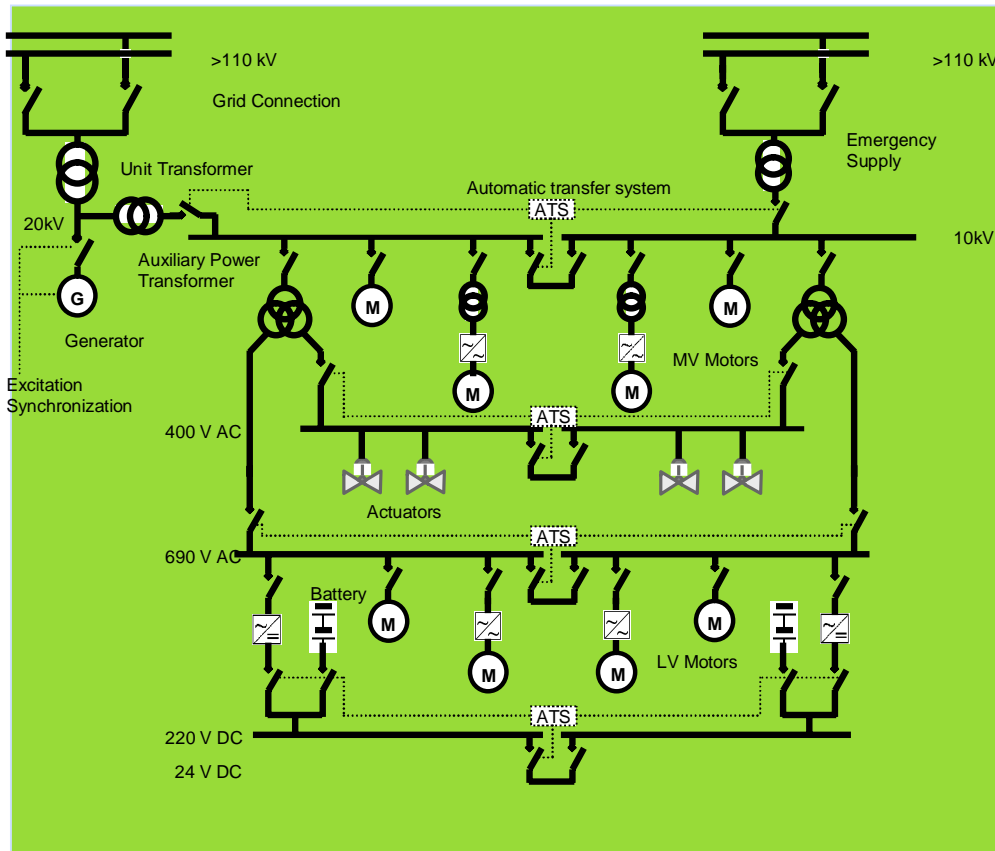

- Energy Efficiency
- Short-circuit calculation
- Definition of voltage levels
- Load flow and voltage drop calculation
- Voltage and reactive power control
- Cable dimensioning
- Selectivity analysis
- Earthing- and lightning-protection
- Layout design of new electrical systems
- Assessment and conceptual engineering for retrofits
- Cost calculations
- Seamless integration of all systems

CCPP solutions

Electrical equipment gas turbine plant

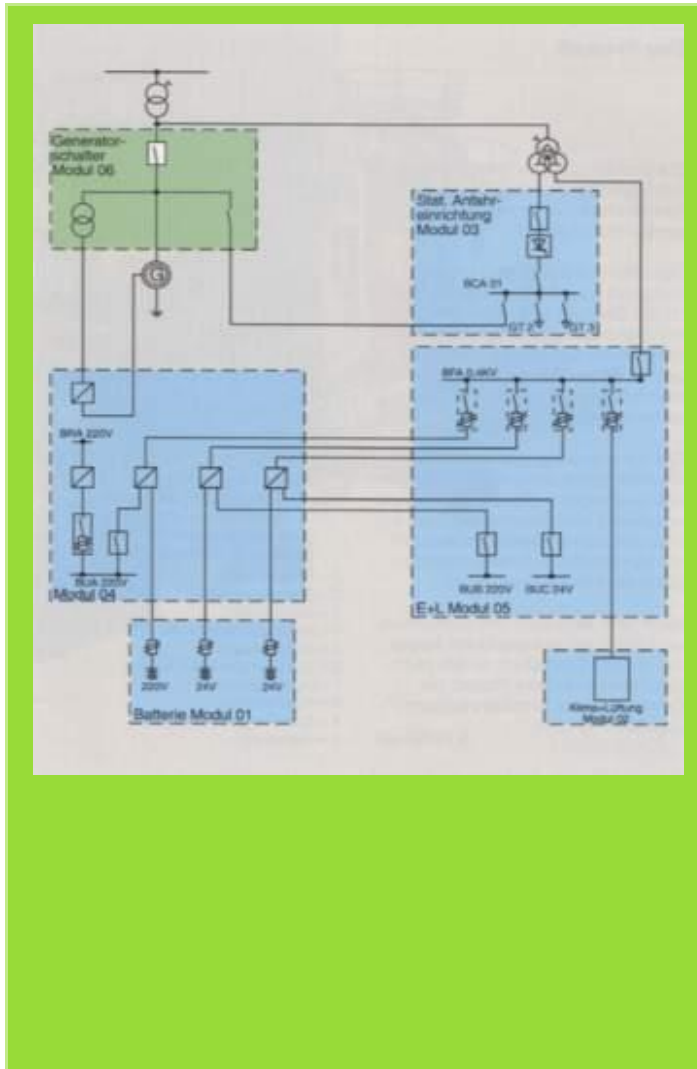

Modular concept for electrical and instrumentation and control

- Static starting device
- Generator circuit-breaker
- Transformers
- Synchronization
- Motor control centers
- Batteries, charger
- Generator protection
- Electrical measurements

DCS: Consistent technology

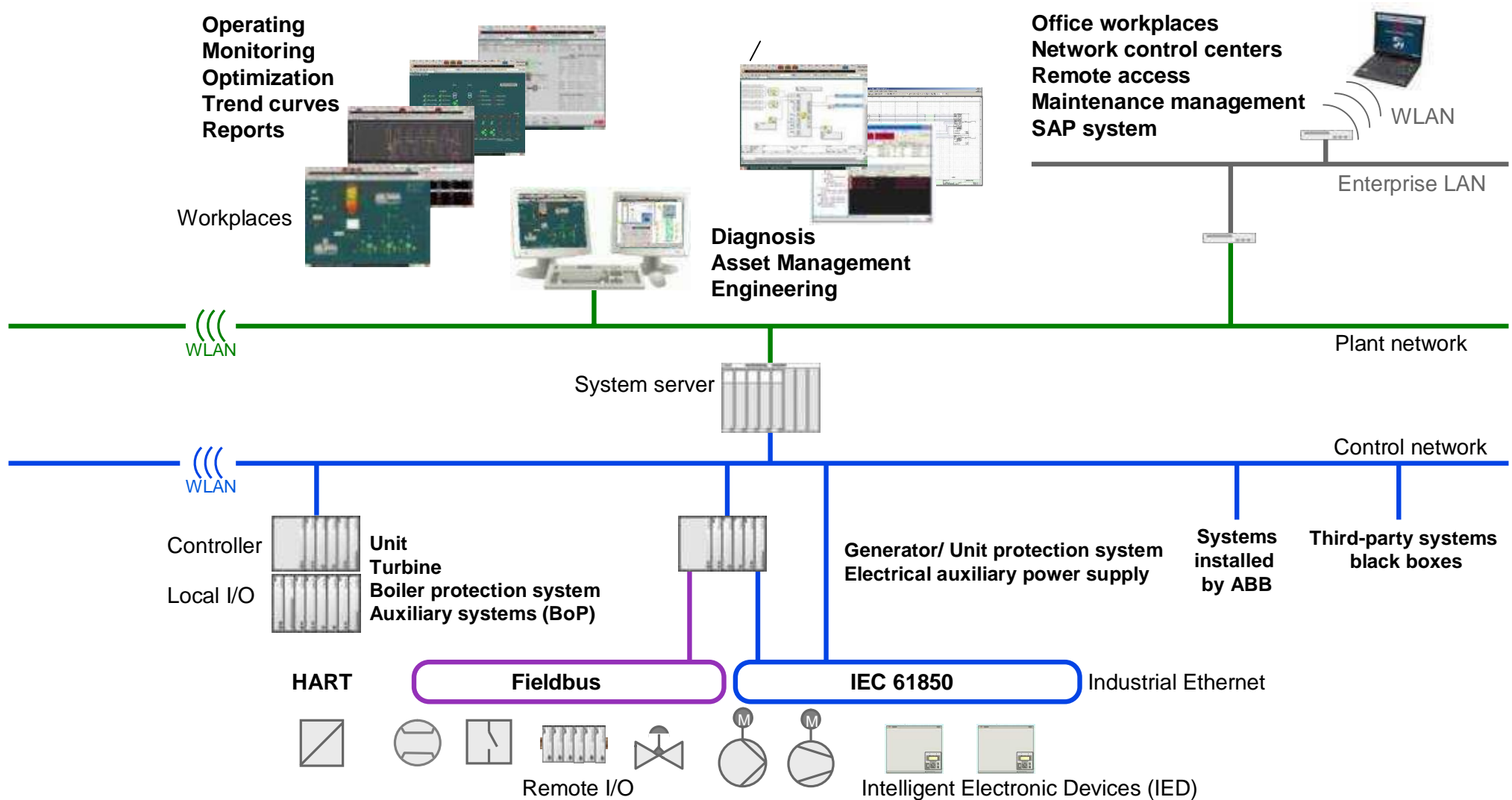

CCPP solutions

Container approach for fast project realization

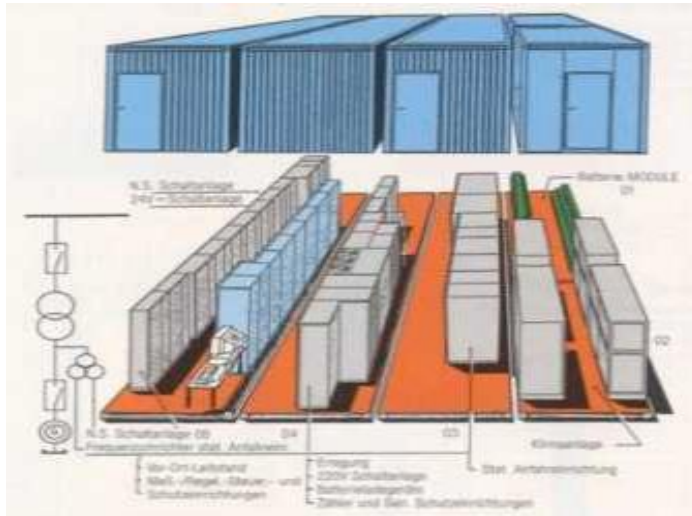

Short execution time for project realization

Complete premanufacturing

Integrated workshop test

Minimized efforts on site for erection and commissioning



Plug and Operate!

CCPP solutions

OPTIMAX[®] plant management and optimization

Optimization

- Boiler Startup Optimization
- Combustion Optimization
- Process/Operation Optimization
- Unit Commitment

Maintenance Management

- Maintenance Management System
- SAP/PM Interface

Information Management

- Information Management System
- Event/Alarm Management
- Electronic Shift Book

Advanced Control

- Unit Control
- Condensate Throttling
- Live Steam Calculator
- State Space Controller

Monitoring

- Loop Performance Monitoring
- Vibration Monitoring
- Emission Monitoring
- Turbine Stress Calculator
- Lifetime Monitoring
- Performance Calculations
- Simulation and Validation

CCPP solutions

Service contracts for CCPP ANP, USA



Business case

- Customer's needs: emergency support with remote and on-site diagnostics, and fault within guaranteed times
- IPP-Independent Power Producer ANP (American National Power)
- Combined cycle power plant

ABB solution

- Modular and flexible service and maintenance contract including service solutions such as preventive maintenance, support line, training, spare parts, repairs and consulting

Customer benefits

- Fast return to normal operating conditions thanks to immediate access to experts
- Reliable budget forecasts due to predictable, regular costs based on quantifiable performance standards

CCPP solutions

Reference: Evolution at Placerita CCPP, USA



Business case

- Existing HSI no longer supported
- Hardware at the end of the life cycle
- Combined cycle power plant

ABB solution

- Evolution of customer specific operational requirements using P13 connectivity and ABB's common 800xA Extended Automation Platform

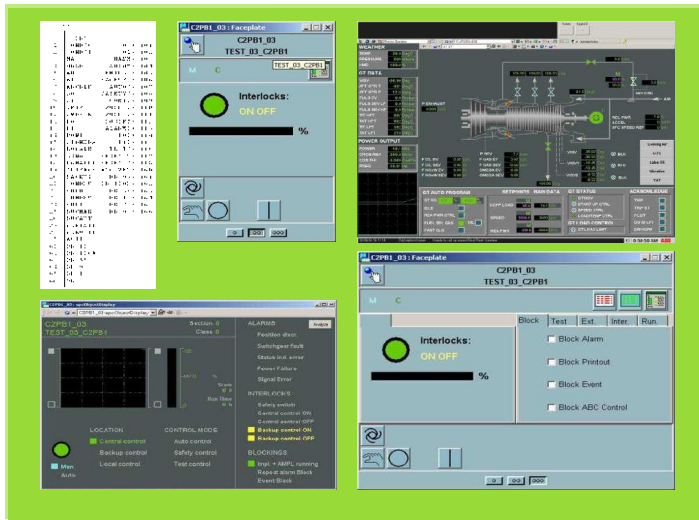

Customer benefits

- No need to exchange the existing DCS
- Operational philosophy remains the same
- Evolution without obsolescence
- Parallel replacement, no downtime

CCPP solutions

Reference: Retrofit at Essent Energy Amer CCPP, NL



Business case

- Customer's need: extend lifecycle
- Combined cycle power plant

ABB solution

- Advant based EGATROL R to replace the Secontic, TR76 and all relay of the old controller

Customer benefits

- Improved availability
- Maximum return on installed investment
- Continuous performance improvements
- Flexible implementations to meet plant needs

CCPP solutions

Reference: Optimization at Fujairah, UAE

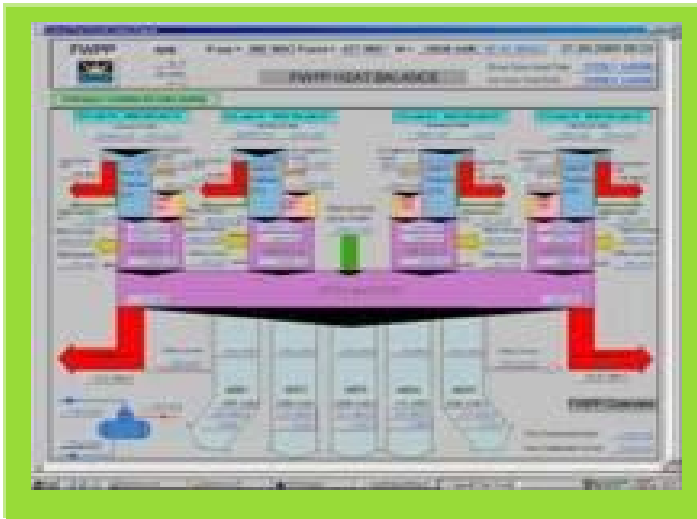

Business case

- Desalination plants play an essential role in power and water production to meet increasing demand
- Hybrid plants are very complex and have a large potential for optimization of operations and maintenance

ABB solution

- **OPTIMAX®** solutions for monitoring and optimization achieved savings of more than 4% in total fuel consumption
- Performance monitoring
- Lifetime monitoring
- Load scheduling
- Hybrid optimization (desalination processes)
- Fuel demand model
- Work process optimization

Customer benefits

- Reduced energy consumption and consumables, extended equipment lifetime, improved preventive maintenance, better information management

CCPP solutions

Reference: CCPP optimization at Alba, BA

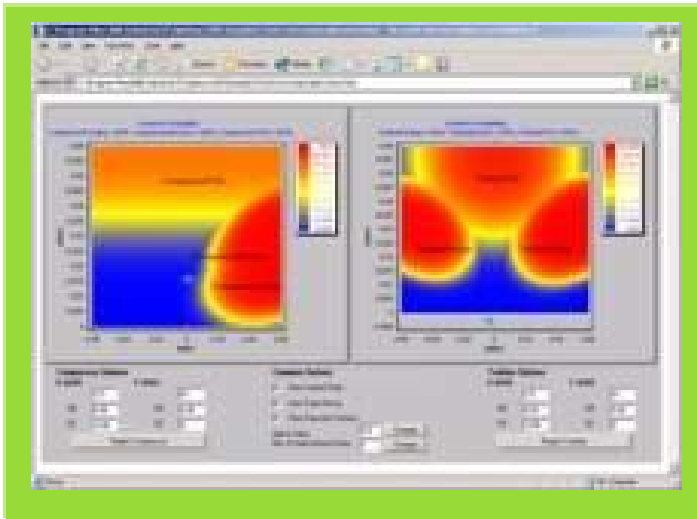
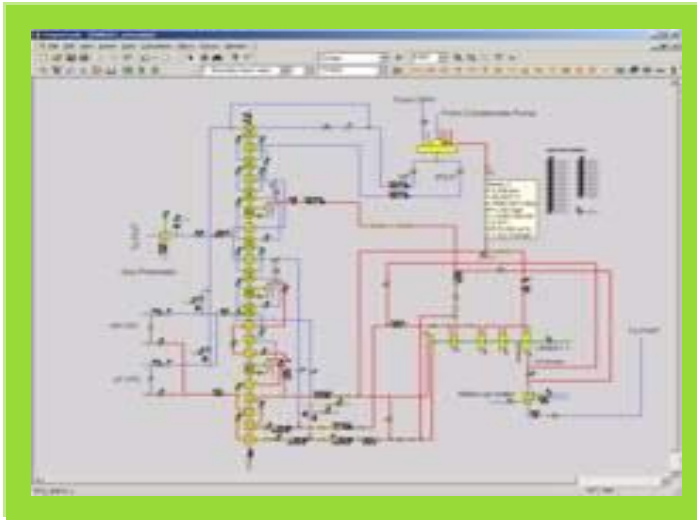

Business case

- CCPP operators are constantly striving to optimize plant operation and lifecycle costs
- The target is powerful diagnostic and optimization tools to identify performance deviations, reduce maintenance effort and extend the life of critical capital equipment

ABB solution

- **OPTIMAX®** solutions for monitoring and diagnosis continuously assess plant condition and provide root cause analysis in case of deviations
- Performance monitoring
- Data validation
- GT gas path diagnosis
- Process information management

Customer benefits

- Early detection and rectification of equipment problems
- Improve predictive maintenance and availability
- Reduce fuel consumption and emissions

CCPP solutions

Reference: Integrated control at Midlothian, US



Business case

- Independent power producer American National Power operates the CCPP in Midlothian as a merchant power plant
- Multiple power plant units of the Alstom KA24-1 ICS reference plant type

ABB solution

- Integrated process automation system Advant Power Control
- GT & ST control systems are integrated with other plant components (boiler, water/steam cycle) as well as with overall plant control

Customer benefits

- Common control system
- Increased plant reliability and availability
- Reduced operation and maintenance cost
- Investment protection by ABB's migration policy

CCPP solutions

Reference: OPTIMAX at South Coast Power, UK



Business case

- Plant type fulfilling new market demands of fast dispatching
- Must be able to startup and shutdown more than 250 times per year
- CCPP delivers 400 MW of electricity to the local and national grids
- Based on the Alstom GT26 gas turbine

ABB solution

- Complete CCPP automation solution including plant performance and optimization system "Optimax"
- Optimax monitors the main components such as the gas turbine, steam turbine, heat recovery steam generator and reveals performance degradation

Customer benefits

- Reduced maintenance and optimized operational costs by scheduled service intervals and by eliminated unplanned outages

CCPP solutions

Reference: OPTIMAX at Enfield, UK



Business case

- IPP-Independent Power Producer “Enfield Energy Centre Limited” purchased a CCPP from Alstom in 1997
- Located near London’s 7 million inhabitants it must meet strict emission and noise requirements
- The power plant delivers 400 MW of electricity to the national grid
- Merchant Plant: operate in base load during the winter periods and two shifts during the summer

ABB solution

- Complete combined cycle power plant automation solution including plant performance and optimization system “Optimax”
- Optimax monitors the main components such as the GT, ST, heat recovery steam generator and reveals performance degradation

Customer benefits

- Reduced maintenance and optimized operational costs by scheduled service intervals and by eliminated unplanned outages

Ras Laffan C, CCPP, Qatar



Ras Laffan, C,
Combined Cycle
Power Plant
2,730 MW, 286,000
cubic meter of
potable water per
day, Qatar
Customer: Hyundai
Engineering and
Construction
(HDEC), Korea
End-customer: Ras
Girtas IWPP
- Consortium Suez
Energy
International/ Mitsui
Electricity
- Qatar Water
Corporation
- Qatar Petroleum
Completion: 2011

Customer need

Highly efficient, environmentally friendly, state-of-the-art gas and steam turbine power plant
Reliable contractor for the supply of the power systems and the grid connections of the plant
Ras Laffan C plant will be the largest power generation and water desalination project in the country

ABB's response

State-of-the-art turnkey electrical system
800-MVA transformers, generator bus duct and breakers, medium- and low-voltage switchgear, emergency power supply and the plant's cable systems
400, 220 and 132-kV GIS substation to connect the plant to the grid fulfilling all grid codes and standards

Customer benefits

Single source and responsibility towards EPC and end-user with short delivery time and optimized interfaces
Short installation and commissioning time
ABB's knowledge and experience with complex power systems

Magnum IGCC 1300 MW, Netherlands



Nuon Magnum
Power Plant
1300MW IGCC,
Eemshaven
Netherlands
EPC contractor:
Mitsubishi Heavy
Industries Japan
Customer: Nuon
Completion: 2011

Customer need

- Highly efficient, environmentally friendly, state-of-the-art power plant. To be fired initially with natural gas.
- Nuon aims to convert the power plant into a fully Integrated gasification combined-cycle plant. The gasifier will convert coal and biomass into syngas, which will be used to fuel the combined-cycle units.
- A pre-combustion carbon dioxide capture facility is planned.

ABB's response

- State-of-the-art electrical system equipment and solutions.
- Switchgear housed in modular pre-fabricated units for easy site installation and limited civil engineering costs
- 380-kV GIS substation will be used to connect the plant to the grid.

Customer benefits

- Single source and responsibility towards EPC and enduser with short delivery time and optimized interfaces
- Short installation and commissioning
- Optimized civil cost

Qatalum CCPP, 1350 MW, Qatar



Qatalum, Qatar
Enduser: JV of
Qatar Petroleum
and Norsk Hydro
Customer: General
Electric
Year of
commissioning:
2009

Customer need

- Project realization to supply electrical power to aluminium smelter
 - CCPP with 1350 MW electrical power
 - Turnkey solution for electrical system

ABB's response

- Complete design, engineering, installation and commissioning of electrical system
- Supply includes IP transformer, station transformers, complete power train including generator circuit breakers, HV cable system and GIS substation 220 kV

Customer benefits

- ABB takes full responsibility for engineering and coordination activities towards customer and end-user
- ABB supports GE as EPC to fulfill tight and demanding schedule
- ABB ensures challenging alignment of frequency and voltage between power plant, aluminium smelter and national grid

Staythorpe CCPP, 1650 MW, UK



Staythorpe Power Station
1650MW CCPP,
Nottinghamshire,
UK
EPC contractor:
Alstom Power,
Switzerland
Customer: RWE
Npower UK
Completion: 2010

Customer need

- New, modern, high efficient Combined Cycle Power Plant (CCPP) using the most advanced technologies to maximize efficiency.

ABB's response

- DCS for the power plant including turbine controls for gas and steam turbines, PGIM Information Management system, control room equipment.

Customer benefits

- Common, integrated control system for low life cycle costs, covering DCS, gas turbine and steam turbine control.
- With minimized environmental impact it will produce enough electricity to power ca. 2 million homes

CCPP solutions

Customer benefits

- Complete solution for electrical, control and instrumentation
- Integrated DCS platform for entire process
- Intuitive, consistent user interface
- Plant- and company-wide access to all data
- Integrated plant monitoring and optimization capabilities
- Low operating and maintenance costs
- Well structured system design
- Scalability to fit process extensions during entire power plant life cycle
- Seamless evolution strategy for existing Installation

Power and productivity
for a better world™

