

SVC Light® for grid code compliance of 220 kV steel plant connection

An SVC Light® rated at 35 kV, 0-164 Mvar (capacitive) has been installed in ZPSS (Zhangjiagang Pohang Stainless Steel Co.), a green-field steel plant in Eastern China, comprising a very large electric arc furnace (EAF) for scrap-based stainless steel production. The EAF is rated at 35 kV, 140 MVA and takes its power from the 220 kV public grid. Due to very strict flicker demands at the point of common coupling, the plant could neither be started nor operated without corrective measures to ensure that the grid code is fulfilled with the EAF in operation. What is of concern is maintaining proper power quality in the grid.

The EAF generates several kinds of disturbances, which, unless remedied, result in more or less severe deterioration of power quality. Large and stochastic variations in reactive power consumption give rise to large and rapid grid voltage fluctuations, which show up as illumination flicker, a particularly annoying sensation for people exposed to it.

Furthermore, the EAF is an asymmetrical load on the three-phase feeding grid, giving rise to current and voltage unbalance in the grid. Normally, only very limited levels of grid asymmetry can be allowed without causing deterioration of the power quality for other consumers connected to the same grid. And last but not least, the EAF generates harmonics, odd and even, as well as interharmonics.

The primary task of the SVC Light is to suppress flicker to acceptable levels, but also to yield a high and constant power factor, as well as to limit harmonic distortion and negative phase sequence components generated by the EAF.

Initially, a traditional SVC, i.e. an SVC based on thyristor control of shunt reactive devices, was considered for the task. It was found, however, that the flicker-damping capability of an SVC was insufficient for the purpose, and an SVC Light, a device more potent for the purpose, was decided on instead.

With the SVC Light in operation, a flicker reduction factor > 5 is achieved.

RTDS

Developments in real-time digital simulation technology have now made possible the demanding real-time simulation of multi-level voltage source converters (VSCs) with pulse width modulation (PWM) switching frequencies in the order of 1.5 kHz. In the present case, a state-of-the-art real-time digital simulator



(RTDS®) has been utilized to easily and conveniently demonstrate the flicker improvement factor provided by the actual VSC controls under realistic system conditions.

SVC Light: some salient design features

SVC Light is ABB's trade name for STATCOM, based on a three-level VSC design, utilizing IGBTs (insulated-gate bipolar transistors) as switching elements and a control concept based on PWM. The ZPSS SVC Light is rated at 35 kV, 0-164 Mvar (capacitive), continuously variable over the entire range.

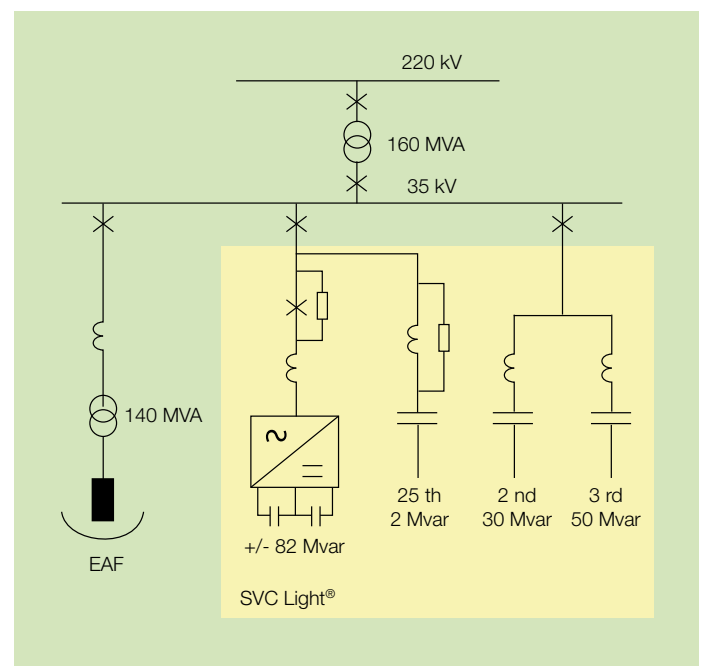

Single-line diagram, SVC Light and EAF.



StakPak™ press-pack IGBTs using 2, 3, 4 and 6 sub-modules for different current handling capacity.

Voltage source converter

The main building blocks of the SVC Light are the VSC, rated at ± 82 Mvar, an air-core phase reactor for coupling the VSC to the 35 kV EAF bus, and an array of parallel harmonic filters rated together at 82 Mvar. The tasks of the harmonic filters are multiple: offsetting the operating range of the SVC Light wholly into the capacitive range (0-164 Mvar); filtering low-order harmonics from the EAF; and filtering high-order harmonics from the VSC.

In the VSC, there are four IGBT valves and two diode valves in each phase leg. The valves are made up of stacked devices with interposed coolers and with external pressure applied to each stack.

One side of the VSC is connected to a capacitor bank which acts as a DC voltage source. The converter produces a variable AC voltage at its output by connecting the positive pole, the neutral, or the negative pole of the capacitor bank directly to any of the converter outputs.

To handle the voltage, the ABB semiconductors are series-connected to reach an adequate total voltage rating. Each IGBT and diode component is built up in a modular housing comprising a number of submodules (in this installation six), each containing a number of semiconductor chips. To provide mechanically robust series connection and to limit requirements on flatness tolerances, each of the submodules is equipped with a system of spring assemblies for each individual chip. The housing frame is also part of the force absorbing system.

Valve assembly

Water cooling by means of de-ionized water is utilized for the IGBT valves, giving a compact converter design and high current handling capacity. A compact design also reduces the loop inductance between the IGBT valves and the DC capacitors, which is beneficial from a loss point of view.

Dry type capacitors

The DC link is built up from DryHED®, an ABB design of compact, high-voltage, dry-type capacitors. The use of metallized film, insulated by means of polymers instead of impregnated materials, gives the capacitors a dry design, making them very environmentally friendly. In manufacturing, they require neither impregnating fluids nor the use of paint solvents. They have high energy density, which enables a very compact DC capacitor bank to be built.

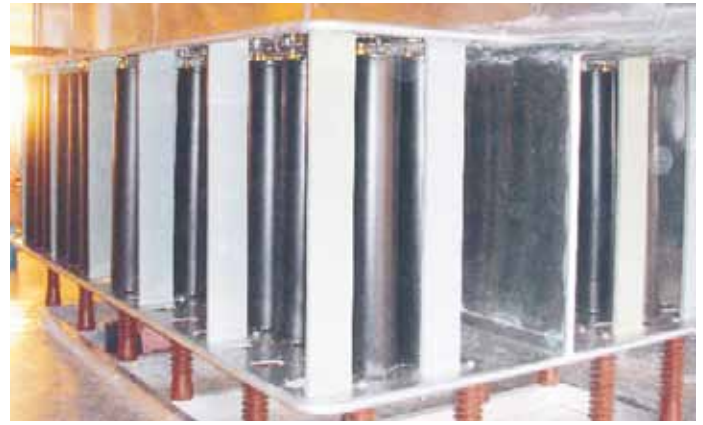

Dry-type DC capacitors for SVC Light.

Control and protection

The SVC Light is controlled to minimize the voltage fluctuations caused by the EAF. This is achieved by open-loop control of the SVC Light current. It not only compensates the entire reactive part of the furnace loads, but also modifies the reactive current reference in order to minimize the effects on flicker caused by active load fluctuations.

Electric arc furnaces disturb the power system by their asymmetrical behaviour. This load unbalance is also compensated for by the SVC Light. It is achieved by “wheeling” active power between phases.

MACH 2

To fulfill the control and protection requirements of the plant, a fully-computerized control and protection system named MACH 2 has been implemented. It uses state-of-the-art computers, microcontrollers and digital signal processors. High performance industrial standard buses and fiber-optic communication links are utilized.

Development in the field of electronics is very fast. The best way to make sure that designs can follow and benefit from this development is to build systems based on open interfaces. The MACH 2 platform is built around an industrial PC, equipped with high performance add-in boards. It also includes a whole family of I/O circuit boards for sampling and signal conditioning.



Converter valve assembly.

Included in the system is also a Human Machine Interface (HMI). This serves as the interface between the operator and the control system. This is performed by an InTouch application running on the OWS/SER (operator workstation/sequence of events recorder) computer. This communicates with the control system via the LAN. The system can be controlled from several different locations, locally in the control room by using the OWS/SER computer, or through digital inputs. It is also possible to dial up the station and connect a remote OWS using a RAS (remote access service) connection.

The system also includes a web-based support (WBS). This makes it possible to enter the system via the internet/LAN or modem and display the state of the station and fetch TFR (transient fault recorder) files.

Test results

After the SVC Light had been commissioned, measurements were undertaken to verify its performance. Some of the results are given here:

Flicker mitigation

With the SVC Light in operation, it turned out to be impossible to detect the EAF contribution to flicker above the existing background flicker level. Due to this, measured absolute Pst values could not be used directly to determine the flicker mitigation efficiency. Instead, an indirect method was used as follows:

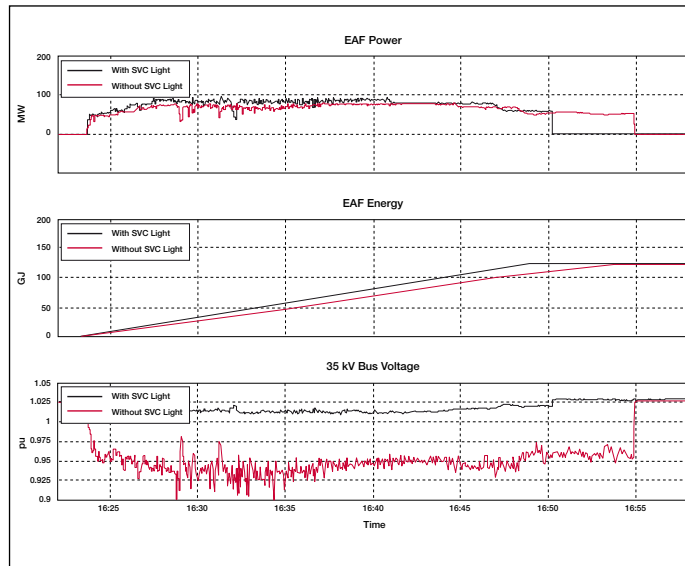

From top to bottom: Active power in the EAF; energy developed in the EAF; EAF bus voltage.

Through a model of the step-down transformer, a virtual primary voltage is calculated as it would have been if only the EAF had been in operation. This voltage is then analyzed with the same algorithm as in a flicker meter and Pst values are obtained. With data from the same time, the flicker from the actual EAF operation with the compensator in operation is determined. By dividing the former flicker values by the latter, a value for the flicker reduction factor is obtained.

Calculating the flicker improvement factor of 95% values has resulted in an improvement factor better than five.

Productivity improvement

In the recordings, a melting cycle is shown, with SVC Light, and without SVC Light, and with the tap changer positions of the furnace transformer the same in both cases. It is clearly seen that the EAF bus voltage is improved with the SVC Light in operation. It is also seen that the full energy of the furnace is reached faster with the SVC Light in operation than without it. And likewise, the melting cycle is completed faster with SVC Light than without SVC Light.

The time gain in the melting cycle indicates a more efficient melting procedure, which brings with it a potential for productivity improvements.

Main technical data

Furnace bus voltage	35 kV
Rated EAF power	140 MVA
SVC Light® rating	35 kV, 0-164 Mvar (capacitive)
VSC	82 MVA; three-level, neutral point clamping converter; IGBT-based, pulse width modulated.
Control system	Open-loop, phase-wise dynamic var control, plus closed-loop power factor control.
Flicker reduction factor	> 5
Power factor at 220 kV PCC	> 0.995

For more information please contact:

ABB AB

FACTS

SE-721 64 Västerås,

SWEDEN

Phone: +46 (0)21 32 50 00

Fax: +46 (0)21 32 48 10

www.abb.com/FACTS