

Performance Verification of the Three-Gorges — Shanghai HVDC Thyristor Modules

Baoliang Sheng, *Senior Member, IEEE*; Fabienne Chataignere;
Giuseppe Simioli; Weimin Ma

Abstract — The design of Three-Gorges — Shanghai (3GS) HVDC thyristor valves is identical to those used in previous two HVDC transmission projects from Three-Gorges hydroelectric power plant. Operational type tests and sample tests of 3GS thyristor valves / modules were re-performed in the synthetic test circuit. The same test parameters are used in test of thyristor modules in all (Three-Gorges) 3G HVDC projects. These parameters stress the test object equal to or greater than those that are foreseen to appear in service.

Fifteen and seven 3GS thyristor modules successfully passed the operational type test and sample test respectively.

Index Terms — Three-Gorges — Shanghai HVDC thyristor modules, performance verification, operational tests

I. INTRODUCTION

SAME as two previous HVDC transmission projects in Three-Gorges hydroelectric power plant [1] the Three-Gorges — Shanghai HVDC transmission project transmits a bulk power of 3000MVA at ± 500 kV from Three-Gorges to Shanghai in China. The design of thyristor valves used in this project is electrically and mechanically identical to those used in two previous Three-Gorges HVDC projects. The thyristor modules were assembled by ABB's local partner Xi'an Power Rectifier Works (XPR), China, according to Transfer of Technology.

A total of twenty-three thyristor modules were shipped to Ludvika, Sweden, for operational type tests and production sample tests. Among those modules fifteen are subjected to type test. A single valve comprises of maximum fifteen thyristor modules in this project.

Both the type tests and sample tests were done in the same synthetic test circuit that was used to type test the Three-Gorges — Changzhou HVDC thyristor modules [2] in 2000.

Giuseppe Simioli, CESI, Via Rubattino 54 - 20134 Milano, Italy (e-mail: simioli@cesi.it)

Weimin Ma, Beijing HVDC Engineering Consultant Co., Ltd, Beijing 100088, China (e-mail: weimin-ma@sgcc.com.cn)

Baoliang Sheng and Fabienne Chataignere, ABB Power Technologies AB, Grid Systems DC, 77180 Ludvika, Sweden (e-mails: baoliang.sheng@se.abb.com and fabienne.chataignere@se.abb.com)

II. THREE-GORGES — SHANGHAI HVDC THYRISTOR VALVES

A double valve structure is used in all Three-Gorges HVDC projects. This valve structure and the valve installation are illustrated in Fig. 1.

High power electrically triggered thyristors (ETT) are used in 3GS HVDC project. A single valve consists of 90 thyristors in series connection in Yidu station and 86 thyristors in Huaxin station. The series-connected thyristors in a valve are grouped into modular units, 6 devices in each. The thyristor module also contains the grading circuits, thyristor electronics, heat sinks and a clamping arrangement. With each thyristor module, one reactor is connected in series. Four modules of each kind are arranged in a horizontal as one layer.

The thyristors and associated auxiliary component in each thyristor level are the same in all Three-Gorges HVDC projects. The thyristor modules used in 3GS HVDC project were assembled by XPR. One of the 3GS HVDC thyristor module (excluding saturable reactor) is shown in Fig.2.



Fig. 1 Valve structure and installation at Longquan station (Three-Gorges – Changzhou HVDC transmission)

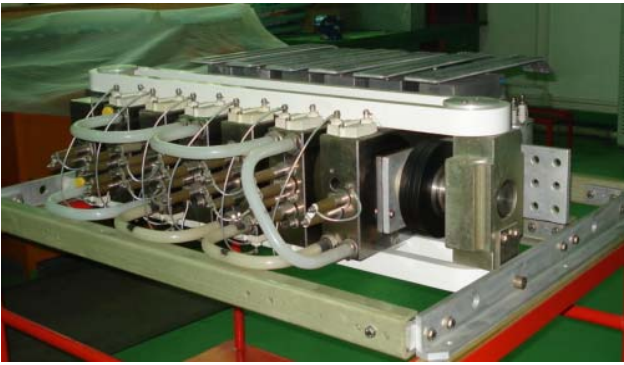

Fig. 2 Front view of 3GS thyristor module

III. TEST CIRCUIT AND OPERATIONAL TESTS

The operational tests of the 3GS HVDC thyristor modules were conducted in a synthetic test circuit. This synthetic test circuit, Fig.3, is the state-of-the-art in testing of modern HVDC thyristor modules [2] [3].

As illustrated from the circuit diagram, Fig. 3, the test circuit consists of a conventional six-pulse Back-to-Back (BtB) circuit, Fig. 4, and a high voltage oscillating circuit. This combination inherits the better test equivalence by a traditional BtB test circuit and remedies the low voltage problem from BtB by the high voltage circuit. Some test duties, for example minimum AC voltage test and temporary under voltage test, can be done in the BtB part alone.

The objectives of operational tests are [4]:

- to check the adequacy of the thyristor levels and associated electrical circuits in a valve with regard to current, voltage and temperature stresses at turn-on and turn-off under the worst repetitive stress conditions
- to demonstrate correct performance of the valve at minimum repetitive voltage, coincident with minimum delay and extinction angles at maximum temperature
- to check the valve, at maximum temperature will tolerate (either withstand or turn-on safely) the application of transient forward voltage in the period immediately following current extinction
- to confirm that, for transients in the forward direction applied after the recovery interval, the protective firing level and dU/dt withstand are consistent with the design
- to confirm the capability of suppressing / surviving a one-loop fault current of maximum amplitude / a multiple-loop fault current, commencing from maximum temperature and blocking the ensuring reverse and forward voltages (in one-loop fault current test only), including any over-voltage due to load rejection.

The test circuit parameters have to be carefully chosen in order to be the representative of system conditions, and to adequately reproduce the stresses on the thyristor modules. The test circuit shall produce the right test parameters as follows during the operational tests:

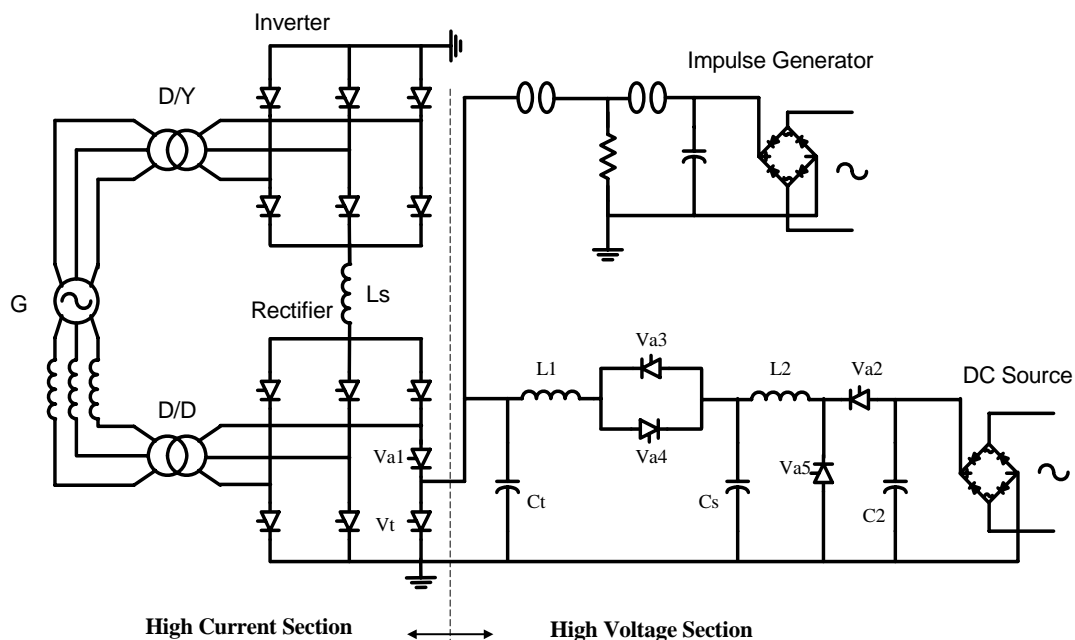

Fig. 3 Test circuit for the operational tests of 3GS HVDC thyristor modules

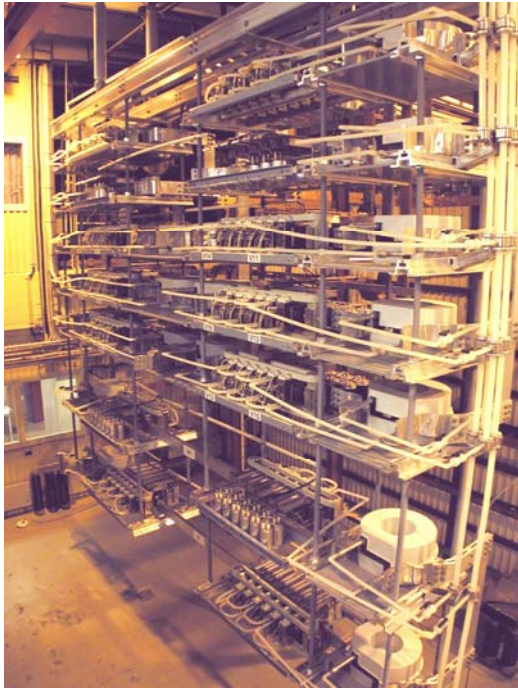

Fig. 4 BtB bridges, auxiliary valve and test modules

- Inlet coolant temperature
- DC test current
- Current derivative prior to the current zero crossing
- Rate of rise of recovery voltage and recovery voltage peak
- Stray capacitance and forward voltage

IV. TEST DESCRIPTIONS

The complete operational type test program, as required in IEC60700-1 (2003) and the Technical Specifications of 3GS HVDC Thyristor Valves, has been strictly followed during the tests for 3GS thyristor modules. The whole operational test program for the 3GS HVDC thyristor modules was performed with the above-described synthetic test circuit. The operational test program includes:

- Periodic firing and extinction tests;
 - Maximum continuous operating duty test
 - Maximum temporary operating duty test ($\alpha=90^\circ$)
 - Minimum AC voltage tests
 - Temporary under voltage test
 - Intermittent direct current test
- Tests with transient forward voltage during the recovery period;
- Valve fault current tests.

A. Test Parameter Determination

Two thyristor modules or 12 thyristor levels were tested in each test set-up. The stresses (incl. safety test factors defined in IEC60700-1) applied to the thyristor modules have been carefully determined for each test duty.

The circuit provides a DC test current that directly represents the service current by a six-pulse BtB circuit. The test current is obtained from the specified current in each type of operation mode multiplied by the test safety factor 1.05. The extra thyristor conduction losses due to injected current can be treated as a supplementary test safety margin.

The voltage provided from this circuit differs from what appears in service. The circuit parameters in voltage section shall therefore be carefully chosen in order to compensate for the additional voltage damping effect of V_{a1} on V_t as well as the absence of voltage jumps due to adjacent phase valve commutation.

Except the minimum AC voltage tests and temporary under voltage tests (where 0.95 is applied), test safety factor 1.05 is applied to the calculated test voltages.

The test parameters for the operational tests of the 3GS HVDC thyristor modules are given in Table 1.

B. Test Description

As described in [2] before the start of each required test duty, the inlet coolant temperature and its flow rate were carefully controlled. A ten-minute preheating period having the heat-run test parameters was also performed in order to closely represent the pre-load condition of test object before any of the required test duty.

The characteristics of this synthetic test circuit allow to combing several test duties into one. The maximum continuous firing voltage test, maximum continuous recovery voltage test and heat-run test can be performed in one single test. The test parameters and test oscillogram are given in Table 1 and Fig. 5. The red curve (upper trace) is the test current and the blue curve (lower trace) is the test voltage across the test modules.

The maximum temporary operating duty test ($\alpha=90^\circ$) was done with two test series to cover both voltage and losses requirements. Test parameters and test record for 2 sec. test are reported in Table 1 and Fig. 6.

The minimum delay angle test and the minimum extinction angle test were performed in the BtB circuit alone. The parameters used in both tests can cover the temporary under-voltage test well. The one minute test is a supplementary test in both test duties.

The intermittent current tests were done at two duties: one is $\alpha=90^\circ$ operation with maximum a.c. voltage and the other is rectifier minimum α operation with minimum a.c. voltage. Parameters and oscillogram reported in Table 1 are the previous one.

The tests with transient forward voltage during the recovery period were performed with three different impulse waveshapes. The impulse voltage rise times are $1.2\mu s$, $10\mu s$ and $100\mu s$ respectively. Eight impulses of each type of

Table 1 Test parameters and oscillograms for the operational tests of 3GS HVDC thyristor modules

Test Duty	Durati on	I_{dc} (A)	I_{fault} (kA)	U_E (kV)	U_R (kV)	U_F (kV)	$U_{F,bk}$ (kV)	$U_{R,bk}$ (kV)	Test record
Heat-run test	60 min.	≥ 3213		≥ 44.3	≥ 34.3	≥ 34.3			Fig. 5
Max. temporary operating duty ($\alpha=90^\circ$) test	2 sec.	≥ 1050		≥ 65.8	≥ 50.9	≥ 59.8			Fig. 6
	2 sec.	≥ 1050				≥ 51.4			
Min. delay angle test 1	1 min.	≥ 1000				≤ 0.7			Fig. 7
Min. delay angle test 2	15 min.	≥ 3213				≤ 5.4			
Min. extinction angle test 1	1 min.	≥ 1000		≤ 1.6					Fig. 8
Min. extinction angle test 2	15 min.	≥ 3213		≤ 10.8					
Intermittent direct current tests	2 min.	< 200			≥ 34.3				Fig. 9
Tests with transient forward voltage during the recovery period		≥ 3213		≥ 44.3	≥ 34.3				Fig. 10
One-loop fault current with re-applied forward voltage		≥ 3213	≥ 32.7	≥ 44.3	≥ 34.3		≥ 46.1		Fig. 11
Three-loop fault current without re-applied forward voltage		≥ 3213	≥ 34.4	≥ 44.3	≥ 34.3			≥ 26.9	Fig. 12

U_E — transient recovery voltage peak
 $U_{F,bk}$ — forward block voltage peak

U_R — reverse power frequency recovery voltage peak
 $U_{R,bk}$ — reverse block voltage peak

U_F — forward voltage prior to firing

impulses were applied on the test modules at various times in the recovery period according to IEC. The tests with the above impulse waveshapes were conducted in one test set-up, while for the other set-ups only one waveshape was applied. The test parameters and one oscillogram showing active recovery protection are given in Table 1 and Fig. 10.

As illustrated in oscillograms Fig. 11 and Fig. 12 the fault current tests started directly after preheating without any time delay.

During the heat run tests the maximum surface temperatures on thyristor heat sinks, snubber resistors, control units and reactors have been measured. All the measured temperatures were below the expected values.

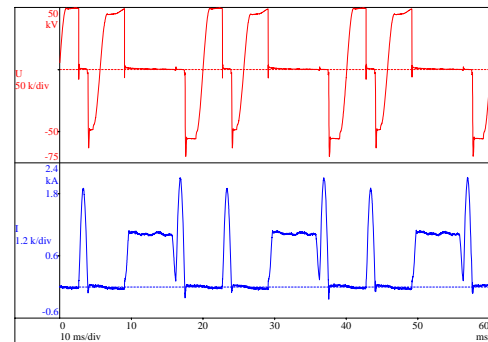

Fig. 6 Maximum temporary operating duty test ($\alpha=90^\circ$)

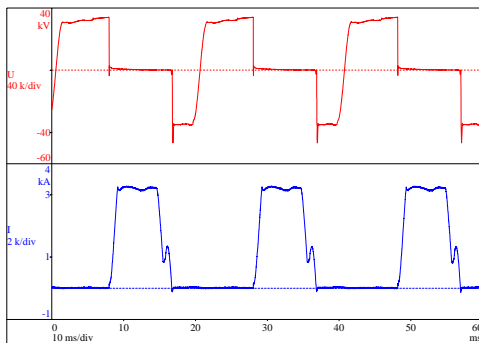

Fig. 5 Periodic firing and extinction tests

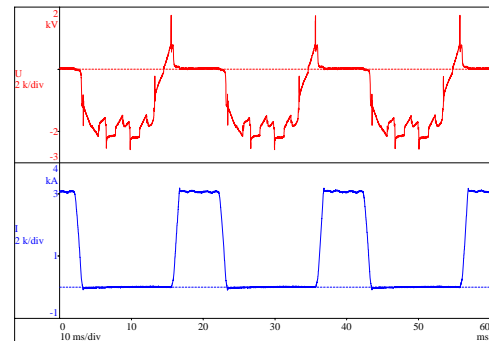

Fig. 7 Minimum delay angle test

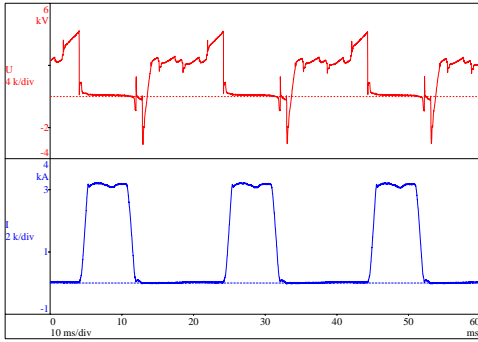

Fig. 8 Minimum extinction angle test

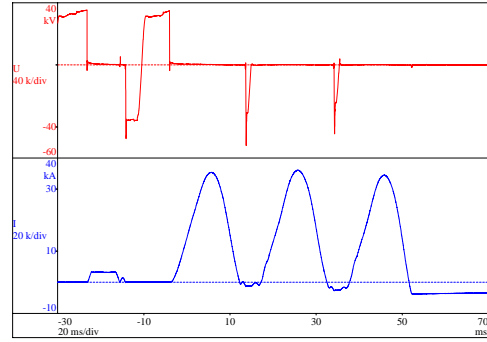

Fig. 12 Three-loop fault current without re-applied forward voltage

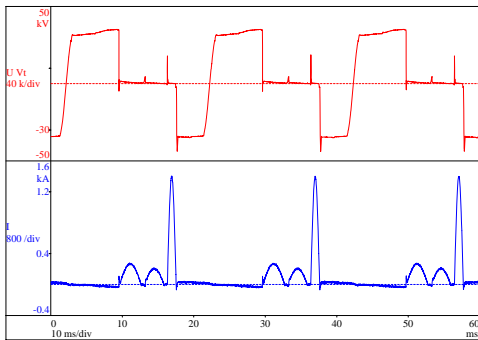

Fig. 9 Intermittent direct current test

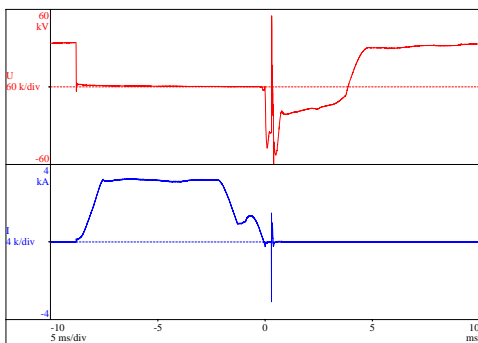

Fig. 10 Tests with transient forward voltage during the recovery period

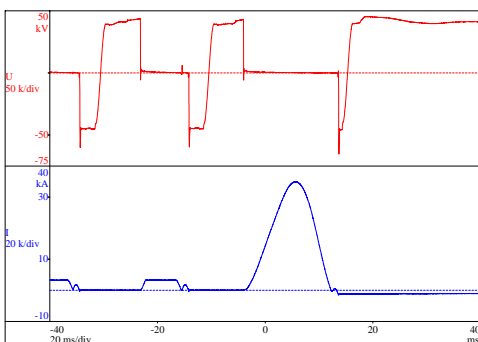

Fig. 11 One-loop fault current with re-applied forward voltage

C. Test Result

No component or part of the thyristor modules was damaged or failed during the operational type tests and sample tests.

The routine tests have been repeated after the operational type tests and sample tests and no defective components were found. There was no evidence of any component degradation after the operational type and sample tests.

The fifteen 3GS HVDC thyristor modules successfully passed the operational type tests and seven modules passed the sample tests.

V. SUMMARY

An industry standard synthetic test circuit was used to verify the production of 3GS HVDC thyristor modules. This synthetic test circuit reproduces the test current and voltage across the thyristor modules closely representative of service conditions. The flexibility in adjustment of test parameters offers a value added merit in developing and testing of modern HVDC thyristor modules.

A total of fifteen 3GS HVDC thyristor modules have been type tested with this synthetic test circuit for the entire operational test program specified by IEC60700-1 (2003) and in the Technical Specifications of 3GS HVDC Thyristor Valves. Seven thyristor modules have been sample tested as specified by the project Technical Specifications.

The successful type test results showed that the transfer of technology in valve design and assembly for 3GS HVDC project is a success. The tested modules have shown a substantial margin in the thyristor valve design since, for most of the tests, the test parameters were globally more severe than specified.

VI. REFERENCES

- [1] R. Dass, et al, "Benefits of Similar HVDC Bipoles From Three Gorges Generation Complex," *CIGRE paper B4-104, session 2004*
- [2] Baoliang Sheng, Hans-Ola Bjarme, Pierre Riffon and Weimin Ma, "Operational Tests of the Three-Gorges — Changzhou HVDC Thyristor

Valves by Using a Synthetic Test Circuit” in *Proc. Cigré ICPS'2001 Conf. on Sep.03-05, 2001, Wuhan, China*, pp.396 – 400

- [3] Baoliang Sheng and Hans-Ola Bjarme, “Proof of Performance — A synthetic test circuit for verifying HVDC thyristor valve design,” in *ABB Review* 03/2003, pp. 25 - 29
- [4] *Thyristor valves for high voltage direct current (HVDC) power transmission - Part 1: Electrical testing*, IEC 60700-1 (2003)
- [5] *IEEE Recommended Practice for Determination of Power Losses in High-Voltage Direct-Current (HVDC) Converter Stations*, IEEE Std 1158-1991

VII. BIOGRAPHIES



Baoliang Sheng obtained his B.Sc degree from Xi’an Jiaotong University, China, and his Ph.D. from Delft University of Technology, the Netherlands, both in Electrical Engineering. From 1982 to 1992 he worked at XIHARI, China, as a test and research engineer. He worked at KEMA, the Netherlands, as a research engineer and towards his Ph.D. at Delft University of Technology from 1992 to 1996. He joined ABB in 1996. He is Company Specialist in High Power Testing of Electrical Power Equipment and Senior Specialist in Testing of HVDC Converter Valves and SVC Valves. He is member of IEC TC33/TC22-SC22F JWG13 and TC22/SC22F/MT9. He is Senior Member of IEEE.



Giuseppe Simioli obtained his M.Sc degree in Electrical Engineering from the Politecnico di Milano, Italy, in 1992. Since 1994 until 2000 he worked at ENEL Research Department, as a research engineer in the Power Electronic Department. Since 2000 he is employed at CESI in the T&D Unit as a senior engineer where he was involved in feasibility studies, technical specification, testing and commissioning supervision concerning power electronic devices in power transmission and distribution systems, in particular, direct current transmission links, electronics devices for power quality improvement and FACTS.



Fabienne Chataignere obtained her M.Sc degree in Electrical Engineering from The Royal Institute of Technology, Sweden. She joined ABB in 2001. She is principal engineer in HVDC thyristor valve design in ABB Power Systems.



Weimin Ma obtained his Ph.D. in electrical engineering from Wuhan Institute of Hydraulic and Electric Engineering in 1994. From 1994 to 1996 he worked in Tsinghua University as a post-doctor. He joined State Power of China in 1996 as a senior engineer mainly for the Three Gorges - Changzhou HVDC project, Three Gorges - Guangdong HVDC project and Three Gorges - Shanghai HVDC project technical specification, test supervision and construction. He is the Chief Engineer of Beijing Wanglian HVDC Engineering Technology Co. Ltd (BDCC). He is member of IEC TC22/SC22F/MT9.