

SVC FOR MAINTAINING OF POWER QUALITY IN THE FEEDING GRID IN CONJUNCTION WITH AN ELECTRIC ARC FURNACE IN A STEEL PLANT

Rolf GRÜNBAUM
ABB Power Technologies AB - Sweden
rolf.grunbaum@se.abb.com

Danilo DOSI
ABB Power Technologies SpA - Italy
danilo.dosi@it.abb.com

Leonardo RIZZANI
Ferriere Nord SpA - Italy
LRizzani@pittini.it

INTRODUCTION

Ferriere Nord SpA is a steel plant situated in northern Italy. An SVC is in operation in its Electric Arc Furnace (EAF) based melt shop. The SVC was installed in order to mitigate flicker generated by the EAF, however, also other benefits such as increased furnace production and decreased energy losses were considered. At a later stage, it was discovered that the SVC gives increased flexibility of the feeding power system. This increased flexibility will be important for the future extension.

The SVC installation has led to better furnace performance in respect to increased available power and less electrode consumption.

THE CASE

Ferriere Nord SpA is a steel plant situated in northern Italy. Since 2002, it has a Static Var Compensator (SVC) in operation in its Electric Arc Furnace (EAF) based melt shop. The SVC was installed in order to mitigate flicker generated by the EAF, however, also other benefits such as increased furnace productivity and decreased energy losses were considered. The installation was part of a general meltshop expansion which also comprised the uprating of an existing EAF transformer from 55 MVA to 75/85 MVA. There is also a Ladle Furnace for refining in the plant, rated at 32 MVA.

The SVC has replaced an old Saturable Reactor which was operated in series with the EAF. Furthermore, a fixed series reactor has been included in the EAF circuit, for stabilizing of the arcing process in the furnace.

In general, Electric Arc Furnaces represent troublesome loads on the feeding three-phase power supply, usually the public grid. The EAF has strong and stochastically fluctuating reactive power consumption, which, unless remedied, will lead to voltage fluctuations and flicker. Furthermore, the EAF acts as an unbalanced load, creating negative-phase sequence components in currents and voltages, which will have a detrimental impact on other installations connected to the same grid as the EAF. And finally, the EAF is a strong source of harmonics.

SVC is an efficient means of mitigating the above mentioned threats to power quality in the plant as well as in the feeding grid. The outcome is a winning situation for everybody: the Grid Code established by the grid company is fulfilled. Other consumers of power connected to the same grid are spared the nuisance of disturbances emanating from the steel plant. And last but not least, the steel manufacturer can operate his plant

without infringing on his operational agreements with the power supplier.

It has also been mentioned that as an additional benefit, productivity will in many cases be improved.

The SVC is rated at 21 kV, 0-90 Mvar, and comprises a Thyristor-Controlled Reactor (TCR) rated at 90 Mvar and three Harmonic Filters altogether also rated at 90 Mvar.

EAF: GRID IMPACT

An EAF is a heavy consumer not only of active power, but also of reactive power. Also, the physical process inside the furnace (electric melting) is erratic in its nature, with one or several electrodes striking electric arcs between furnace and scrap. As a consequence, the consumption especially of reactive power becomes strongly fluctuating in a stochastic way. The voltage drop caused by reactive power flowing through circuit reactances therefore becomes fluctuating in an erratic way, as well. This gives rise to voltage flicker and is visualized most clearly in the flickering light of incandescent lamps fed from the polluted grid.

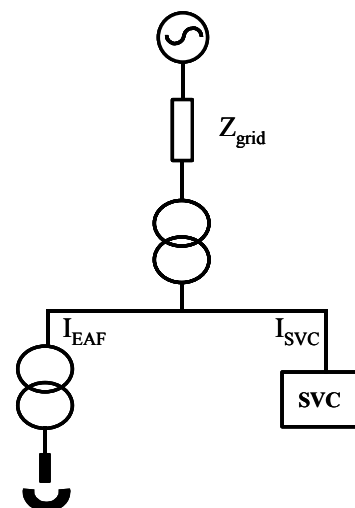

Fig. 1: Network diagram: EAF, SVC and feeding grid.

The amount of flicker that arises as a consequence of electric arc furnaces being fed from grids of limited strength depends on the size of the EAF on one hand and the short circuit power of the grid at the point of common connection (PCC) on the other, reflected in the grid short circuit impedance Z_{grid} (Figure 1). With an EAF of a short circuit rating S_{SCEAF} and a short circuit power of the grid S_{SC} , a qualitative idea of the

amount of flicker that can be expected can be derived from the expression

$$P_{st} = K_{st} \times S_{SCEAF} / S_{SC} \quad (1)$$

The constant K_{st} (“severity factor”) usually lies in the range of 75 for cold start-up of the furnace. In the given case, the grid is relatively weak (slightly less than 3.000 MVA at the 220 kV PCC). This together with the uprating of the EAF from 55 MVA to 75/85 MVA, unless properly remedied, would have resulted in sizeable amounts of flicker.

The situation is aggravated by the appearance of interharmonics in the furnace current, interacting in a nonlinear way to produce additional flicker components. Spectral analysis confirms that lamp flicker caused by EAF action is severe around frequencies for which the human eye is particularly sensitive, i.e. below 20 cycles. And for certain, flicker is a very annoying sensation and becomes easily a source of complaint.

The EAF is also a strong source of harmonics as well as phase unbalance, needing to be dealt with, as well, for safeguarding of proper power quality in the grid.

From the above it is obvious that by minimising the flow of reactive power through the grid and circuit impedances, voltage fluctuations are minimised, as well. Flicker reduction follows immediately from this. In terms of Figure 1, this condition can be expressed as

$$I_{SVC} + I_{EAF} \text{ (reactive)} = 0 \quad (2)$$

To parry the rapidly fluctuating consumption of reactive power of arc furnaces, an equally rapid compensating device is required. This is the task of the SVC [1]. The SVC has the following purposes:

- Keep a good and stable power factor at the point of common connection, independently of the reactive power fluctuations from the furnace loads.
- Reduce the flicker at the 220 kV point of common connection to acceptable levels.
- Filter the harmonics generated by the furnaces.
- Stabilise the system voltage at the 21 kV load bus.

MAIN SVC DESIGN

Basic SVC configuration

The SVC comprises the following main equipment (Figure 2):

- A TCR (Thyristor Controlled Reactor) rated at 90 Mvar.
- A 2nd Harmonic Filter rated at 30 Mvar.
- A 3rd Harmonic Filter rated at 30 Mvar.
- A 4th Harmonic Filter rated at 30 Mvar.

The functional principle of the TCR is shown in Figure 3. By phase angle control of the shunt reactor, the RMS value of the current through the reactor can be continuously controlled

from zero up to the value given by the rated inductance of the reactor.

The harmonics generated in this scheme are absorbed in the harmonic filters which are also part of the SVC.

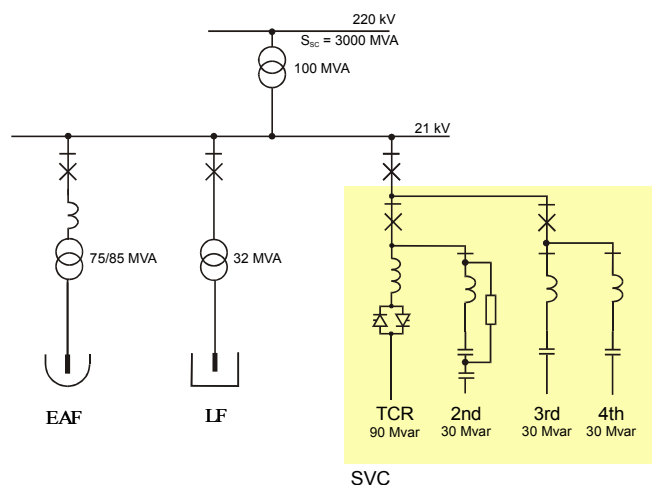

Fig. 2: Single-line diagram of the furnaces and the SVC.

Together with the capacitive reactive generation yielded by the Harmonic Filters at 50 Hz, the total dynamic range of the SVC can be made capacitive. Thus, the overall dynamic range of the SVC in the given case is 0-90 Mvar (capacitive).

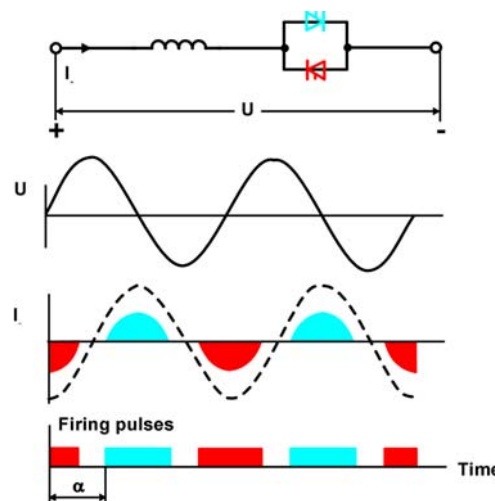

Fig. 3: Functional principle of TCR.

The SVC has been designed to enable the following performance at the 220 kV point of common connection, with the furnaces as well as the SVC in full operation:

- Power factor, P.F. ≥ 0.95
- Voltage flicker, short term, $P_{st95} \leq 1.5$
- Total harmonic voltage distortion, THD $\leq 1.5\%$

Actual values measured during test runs of the installation not only fulfilled the demands, but surpassed them. Thus, the power factor attained 0.99; flicker (P_{st95}) did not exceed 1.3, and THD was less than 1%.

TCR design features

Thyristor valve. The thyristor valve is of BCT type, i.e. equipped with Bidirectionally Conducting Thyristors (Figure 4). In such devices, two thyristors are integrated into one wafer with separate gate contacts.

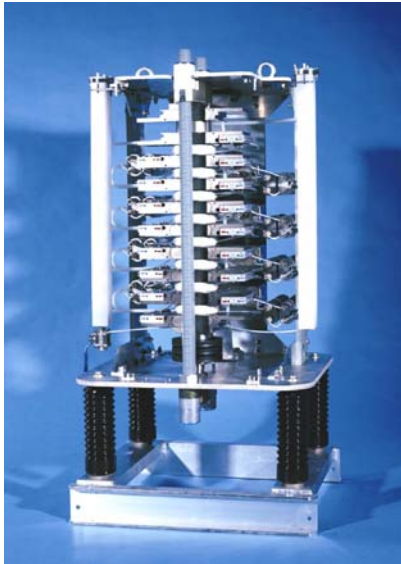

Fig. 4 : Thyristor valve (one phase out of three).

The two component thyristors in the BCT function completely independently of each other under static as well as dynamic operating conditions. Each component thyristor in the BCT has a performance equal to that of a separate conventional device of the same current carrying capability. The valve comprises only one thyristor stack in each phase instead of two, which offers considerable compactness of the valve design.

The thyristor valve is cooled by means of de-ionised water.

Air core reactor. In the SVC, an air core TCR reactor is utilized, glass fibre insulated and epoxy resin impregnated. This gives a robust, environmentally sturdy design, self ventilated, with inherently linear characteristics.

Harmonic filters

Arc furnaces display a harmonic spectrum of even as well as odd harmonics, and, during the initial melt down period, a continuous spectrum of interharmonics. Characteristic harmonics are the 2nd, 3rd, 4th, 5th etc.

In addition to the harmonics generated by the furnaces, the harmonics from the TCR have to be taken into consideration, as well. The TCR generates harmonic currents which are a function of the control angle of the TCR. Characteristic harmonics are the 3rd, 5th, 7th, 9th, 11th and 13th.

The harmonic filters of the SVC have been designed in order to meet harmonic distortion requirements, generate the appropriate amounts of reactive power, and ensure that all possible resonant modes with the power grid are avoided.

The optimum use of the total reactive power for filtering purposes is achieved by dividing the total reactive power into three different filters tuned to the 2nd, 3rd and 4th harmonics. By introducing damping in the 2nd harmonic filter, interharmonic and parallel resonance problems can be mastered.

2nd harmonic filter. This filter has been designed as a C-type filter, consisting of a reactor and a capacitor connected in series in order to reach the required filter tuning (Figure 2). The capacitor is divided into two parts in series, with a resistor connected over the tuning reactor and nearest capacitor part. The latter part is chosen such that it forms a series resonance circuit with the reactor at the fundamental frequency. The fundamental current is thus bypassed the resistor, and losses are avoided.

3rd and 4th harmonic filters. These filters have been designed as Band Pass Filters and consist of a reactor and a capacitor in series in order to reach the required filter tuning (Figure 2).

A view of the SVC installation is shown in Figure 5.



Fig. 5: Site view of the SVC at Ferriere Nord, Osoppo.

SVC control

The control system is based on the MACH 2 concept, which is a system of both hardware and software, specifically developed for power applications. The MACH 2 concept is built around an industrial PC with add-in boards and I/O racks connected through standard type field busses like CAN and TDM.

The MACH 2 control concept is developed to be insensitive to severe harmonics in the control inputs. It is an obvious requirement that the SVC is insensitive to and does not amplify any harmonic resonant condition in the power system.

The input signals to the control system are generated in current and voltage transformers that are located in different places of the plant. These are used by the control system for controlling, supervising and synchronizing purposes. The

flicker level measured with the furnaces and the SVC in operation.

The resulting flicker value at 220 kV with the SVC in operation was $P_{st95} = 1.3$, which was better than the demanded value of $P_{st95} \leq 1.5$.

Summary, performance results

The following table summarises the attained performance tests and makes a comparison with the requirements.

	Measured value	Required value
Power factor	0.99	≥ 0.95
THD	0.97%	$\leq 1.5\%$
Flicker, P_{st95}	1.30	≤ 1.5

POTENTIAL PRODUCTIVITY IMPROVEMENTS

The SVC not only mitigates random voltage fluctuations at the PCC, but also brings about a genuine increase of the RMS value of the EAF bus voltage, Figure 8. This has provided higher active power in the furnace, which can be utilized to the benefit of the steel plant as follows:

- Shorter melting times
- Reduced specific electrode consumption
- Reduced specific energy losses
- Reduced wear of furnace lining.

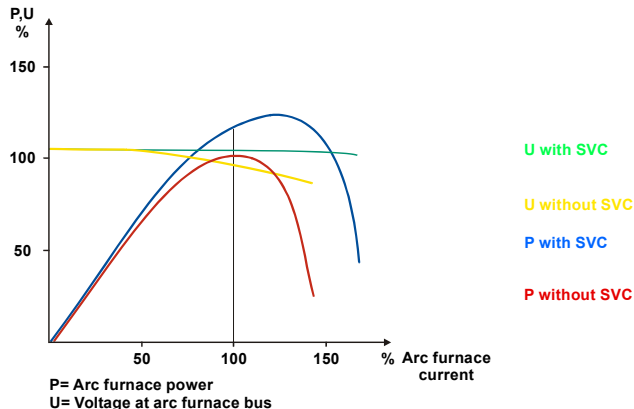

Fig. 8: EAF limits of operation without and with SVC.

The improvement of the power factor at the PCC furthermore enables a reduction of plant losses emanating from the flow of reactive power, plus opens up for more favourable power rates from the local utility.

These factors all offer potential for improving plant productivity and economy.

Increased productivity

By means of the SVC, the busbar voltage is stabilised to have an increased available power of 6-7% at the furnace in the given case. Due to this increased active power yield in the EAF, each tonne of scrap needs less time for melting. This

can be used to increase the total production output of the plant. Alternatively, it can be utilised for additional flexibility in the production pattern, for instance, to simplify the meeting of peak demands.

Electrode savings

The graphite electrode consumption can be split into two constituents:

- Side oxidation, mainly dependent on tap to tap time.
- Tip consumption, mainly dependent on electrode current.

In the given case, electrode current remains the same, with the tap to tap time reduced. Reduction in side oxidation results, leading to reduced electrode consumption.

Loss reduction

With decreased tap to tap times, specific furnace losses, equal to losses per melt, decrease, as well. Furthermore, as mentioned above, electric losses from the substation to the furnace are decreased, due to smaller flows of reactive power.

Refractory savings

Specific refractory wear, i.e. wear per melt, is decreased due to the shorter time spent for each melt. Furthermore, the more efficient and stable arcing in the EAF due to the SVC and series reactor results in reduced refractory wear, as well.

To summarise in the given case:

- Electrode saving (kg/tonne steel) 2-3 %
- Loss reduction (kWh/tonne steel) 2-3 %

CONCLUSION

An SVC is in operation in the Electric Arc Furnace (EAF) based melt shop of Ferriere Nord. The SVC was installed in order to mitigate flicker generated by the EAF, however, also other benefits such as increased furnace productivity and decreased energy losses were considered.

By means of the SVC, with the EAF and Ladle Furnace in operation, the flicker severity factor at the 220 kV point of common connection has been limited to $P_{st95} = 1.3$.

The SVC installation has also led to better furnace performance in respect to increased available power and less electrode consumption.

REFERENCES

- [1] Lars Hultqvist et al, "State of the art Var Compensators", 1999 *Electric Furnace Conference Proceedings*, Iron & Steel Society, Pittsburgh, USA.