

SVC Light: a powerful flicker mitigator

Rolf Grünbaum, Tomas Gustafsson
ABB Power Systems AB
SE-721 64 Vasteras, Sweden
Phone:+46 21 32 40 00; Fax: +46 21 18 31 43

Thomas Johansson
ABB Power T&D Company Inc.
Raleigh NC
Phone: (919) 856 2379; Fax: (919) 856 2412

Key Words: EAF, Power quality, SVC Light, VSC, IGBT, Flicker mitigation, Harmonic filtering, load balancing, productivity improvement.

INTRODUCTION

With the advent of continuously controllable semiconductors for high power, voltage source converters far into the tens of MVA range have become feasible. With ABBs SVC Light concept, VSC (Voltage Source Converters) and IGBT (Insulated Gate Bipolar Transistors) have been brought together to offer possibilities hitherto unseen for power quality improvement in the high power range.

This opens up new options for power quality control in areas such as voltage flicker from electric arc furnaces ranging from a couple of tens of MVA up to ratings exceeding 100 MVA.

The paper describes the SVC Light, its technology as well as application, and comments on its abilities for power quality enhancement by decreasing or eliminating phenomena such as voltage flicker, harmonic distortion and phase unbalance.

As a current example of the usefulness of SVC Light, an installation for flicker mitigation has been installed at Hagfors steel mill in Sweden.

POWER QUALITY: A MATTER IN FOCUS

Modern society relies heavily upon electricity. With deregulation, electricity has become a commodity as well as a means for competition. Power quality, as a consequence, is coming into focus to an extent hitherto unseen. Industry as well as commercial and domestic groups of users simply demand power quality. Flickering lamps and TV sets are no longer accepted, nor are deratings or interruptions of industrial processes due to insufficient power quality.

In fact, the interruption of an industrial process for instance due to a voltage sag can result in very substantial costs to the operation. These costs include lost productivity, labour costs for cleaning and restart, damaged product, reduced product quality, delays in delivery, and reduced customer satisfaction. Thus, costs previously hidden in poor power quality are brought forward to their face value.

Another example: for a steel maker, an electric arc furnace (EAF) is a piece of equipment needed to make his product. For the grid owner and for the supplier of electricity, the EAF user is a subscriber to power, i.e. a customer, but in the worst case also a polluter of the grid. Out of the EAF may well come an abundance of distortion such as voltage fluctuations, harmonics and phase unsymmetry. Also, the grid may be subject to carrying large amounts of reactive power, which is unintended and gives rise to transmission and distribution losses as well as impedes the flow of useful, active power in the grid.

Disturbances emanating from any particular load will travel far, and, unless properly remedied, spread over the grid to neighbouring facilities.

Thus, for instance, voltage flicker and harmonics may turn up far away from their source and disturb other consumers, urban as well as industrial, and become a nuisance to many. At the end of the day, the disturbing equipment will therefore become an issue to many and not just to the owner of the particular equipment. We are then talking about lack of power quality.

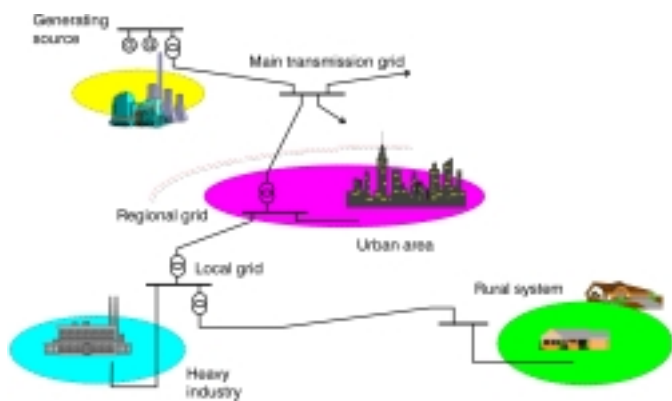

Fig. 1. Disturbances travel far.

Fortunately, there are means to deal with the problem of poor or insufficient power quality in grids. One obvious way is to reinforce the power grid by building of new lines, installing new and bigger transformers, or moving the point of common coupling to a higher voltage level.

Such measures, however, are expensive and time-consuming, if they are at all permitted. As a matter of fact, there is a tendency in the opposite direction at present in some places, with P.C.C.s in some cases being moved to lower voltage levels in the grid.

A simple, straightforward and cost-effective way of power quality improvement in such cases as well as similar is to install equipment especially developed for the purpose in immediate vicinity of the source(s) of disturbance.

As an additional, very useful benefit, improved process economy will often be attained as well, and as a matter of fact enable the said investment to turn out a profitable measure.

Voltage flicker

An electric arc furnace is a heavy consumer not only of active power, but also of reactive power. Also, the physical process inside the furnace (electric melting) is erratic in its nature, with one or several electrodes striking electric arcs between furnace and scrap. As a consequence, the consumption especially of reactive power becomes strongly fluctuating in a stochastic manner (Fig.2).

The voltage drop caused by reactive power flowing through circuit reactances in the electrodes, electrode arms and furnace transformer therefore becomes fluctuating in an erratic way, as well. This is called voltage flicker and is visualized most clearly in the flickering light of incandescent lamps fed from the polluted grid.

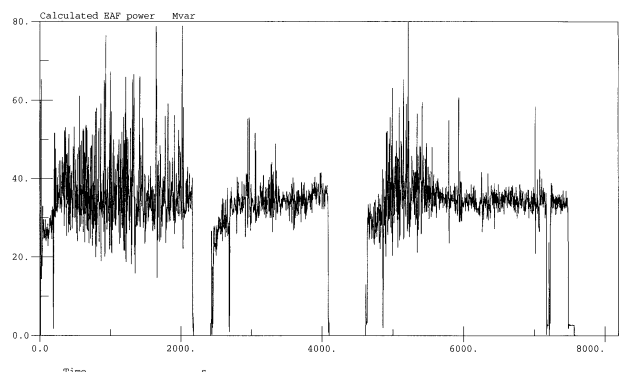

Fig. 2. Reactive power consumption of EAF.

Spectral analysis confirms that lamp flicker caused by EAF action is severe around frequencies for which the human eye is particularly sensitive, i.e. below 20 cycles. And for certain, flicker is a very annoying sensation and becomes easily a source of complaint.

The International Union of Electroheat (UIE) in cooperation with IEC has defined a quantity for expressing flicker severity, P_{st} . According to this terminology, $P_{st} = 1$ means that in a group of people, half can observe light flicker that the group is being exposed to. According to the IEC recommendations the P_{st} planning level for high and extra high voltages should be 0.8 or less.

SVC LIGHT

SVC Light is a flicker mitigating device. It achieves this by attacking the root of the problem, the erratic flow of reactive power through the supply grid down into the furnaces. The reactive power consumption is measured, and corresponding amounts are generated in the SVC Light and injected into the system, thereby decreasing the net reactive power flow to an absolute minimum. As an immediate consequence, voltage flicker is decreased to a minimum, as well.

Important added benefits are a high and constant power factor, regardless of load fluctuations over furnace cycles, as well as a high and stable bus RMS voltage. These benefits can be capitalized as improved furnace productivity as well as decreased operational costs of the process in terms of lower specific electrode and energy consumption and reduced wear on furnace refractories.

To parry the rapidly fluctuating consumption of reactive power of the furnaces, an equally rapid compensating device is required. This is brought

about with state of the art power electronics based on IGBT (Insulated gate bipolar transistor) technology. With the advent of such continuously controllable semiconductor devices capable of high power handling, VSC (Voltage Source Converters) with highly dynamic properties have become feasible far into the tens of MVA range.

The function of the VSC in this context is a fully controllable voltage source matching the bus voltage in phase and frequency, and with an amplitude which can be continuously and rapidly controlled, so as to be used as the tool for reactive power control (Fig.3).

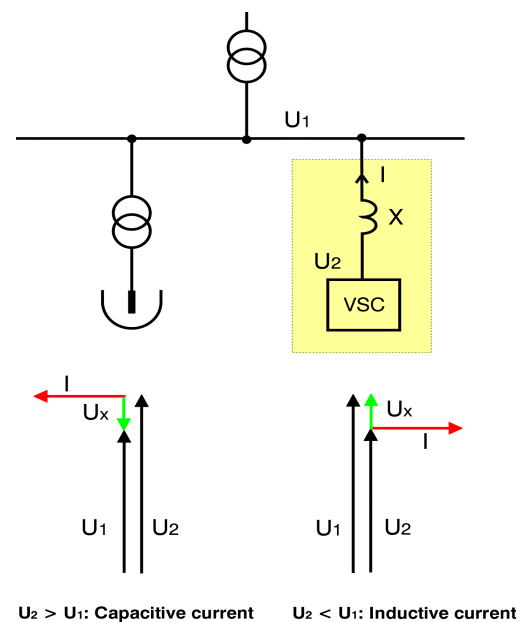

Fig. 3. VSC: a controllable voltage source.

The output of the VSC is connected to the AC system by means of a small reactor. By control of the VSC voltage (U_2) in relation to the bus voltage (U_1), the VSC will appear as a generator or absorber of reactive power, depending on the relationship between the voltages. To this controlled reactive power branch, an offsetting capacitor bank is added

in parallel, enabling the overall control range of the SVC Light to be capacitive.

The reactive power supplied to the network can be controlled very fast. This is done only by changing the switching pattern in the converter slightly. The response time is limited mainly by the switching frequency and the size of the reactor.

The controllability of IGBTs also facilitates series connection of devices with safeguarded voltage sharing across each IGBT. This enables SVC Light to be directly connected to voltages in the tens of kilovolts range. Thanks to this, it becomes unnecessary to parallel converters in order to achieve the power ratings needed for arc furnace compensation (typically tens of MVA).

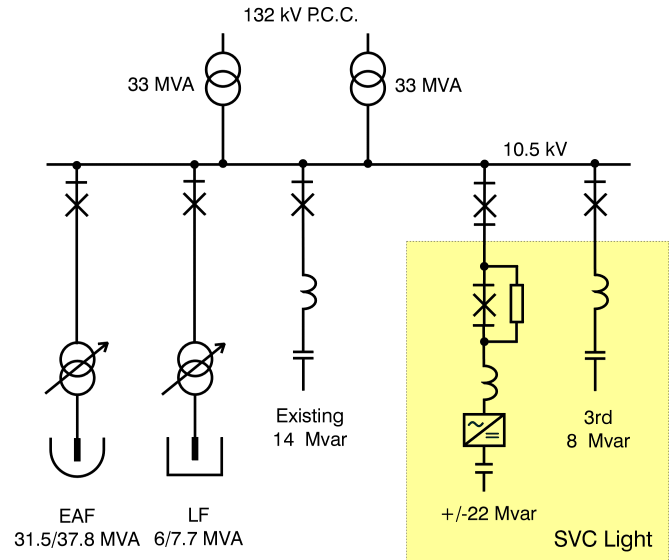

Fig. 4. Single-line diagram of EAF feeding network and compensation.

The SVC Light (Fig.4) is rated at 0 - 44 Mvar of reactive power generation, continuously variable. This dynamic range is attained by means of a VSC rated at 22 MVA in parallel with two harmonic filters, one rated at 14 Mvar existing in the plant initially and one installed as part of the SVC Light undertaking, rated at 8 Mvar. Via its phase reactors, the VSC is connected directly to the furnace bus voltage of 10,5 kV. During the energisation of the VSC, the DC capacitors are charged via the charging resistors. While the DC capacitors are charged, the by-pass switch is closed.

UDDEHOLM TOOLING SVC LIGHT INSTALLATION

Uddeholm Tooling at Hagfors in mid Sweden is a steel producer with its metallurgical process based on scrap melting in an electric arc furnace (EAF) and subsequent refining by means of a ladle furnace (LF). The EAF is rated 31,5 MVA with a 20% temporary overload capability, whereas the LF is rated 6 MVA plus a 30% overload capability. Both furnaces are fed from a 132 kV grid via an intermediate voltage of 10,5 kV (Fig.4).

The feeding grid is relatively weak, with a fault level at the P.C.C. of about 1000 MVA. It is obvious that this is quite insufficient to enable operation of the two furnaces while upkeeping reasonable power quality in the grid.

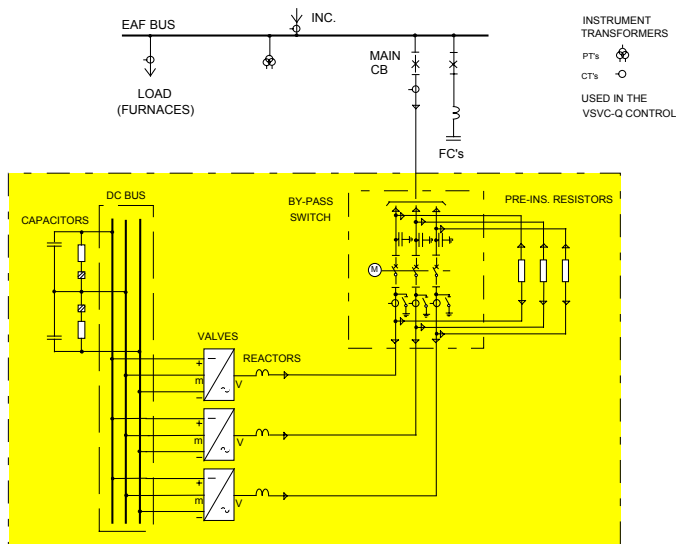

Fig. 5. Main circuit diagram of Hagfors SVC Light.

VOLTAGE SOURCE CONVERTERS

The input of the Voltage Source Converter is connected to a capacitor, which is acting as a DC voltage source. At the output, the converter is creating a variable AC voltage. This is done by connecting the positive pole, neutral or the negative pole of the capacitor directly to any of the converter outputs. In converters that utilise Pulse Width Modulation (PWM), the input DC voltage is normally kept constant. Output voltages such as a sinusoidal AC voltage can be created. The amplitude, the frequency and the phase of the AC voltage can be controlled by changing the switching pattern.

In SVC Light, the VSC uses a switching frequency greater than 1 kHz. The AC voltage across the reactor at full reactive power is only a small fraction of the AC voltage, typically 15 %. This makes SVC Light close to an ideal tool for fast reactive power compensation.

IGBT

For SVC Light the IGBT has been chosen as the most appropriate power device. IGBT allows connecting in series, thanks to low delay times for turn-on and turn-off. It has low switching losses and can thus be used at high switching frequencies. Nowadays, devices are available with both high power handling capability and high reliability, making them suitable for high power converters.

As only a very small power is needed to control the IGBT, the power needed for gate control can be taken from the main circuit. This is highly advantageous in high voltage converters, where series connecting of many devices is used.

Series connecting of IGBTs

At series connection of IGBTs, a proper voltage division is important. Simultaneous turn-on and turn-off of the series connected devices are essential. In SVC Light, the turn-off and turn-on signals are distributed to the individual IGBTs through a high bandwidth fiber optic system. All IGBT positions are also equipped with a special type of gate unit, which turns the IGBTs on and off with a short delay time and at a controlled dV/dt . After turn-off of a IGBT valve or a diode valve, a small voltage difference will be seen between different IGBT positions. Control of this difference in voltage is done by proper design of the resistive and capacitive voltage dividers.

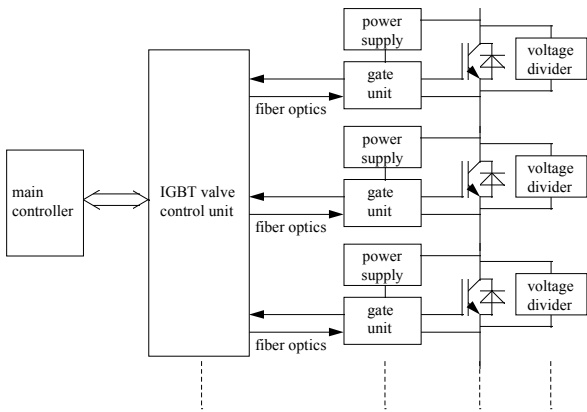

Fig. 6 The IGBT valve, with a number of series-connected IGBTs switched simultaneously

In addition to this, every IGBT position is equipped with an over-voltage monitoring system. This system makes it possible to detect if any IGBT position behaves in an unnormal way already during the delivery test. If this would happen, such devices will be exchanged.

The converter valve

The converter topology for SVC Light is a three level configuration. In a three-level converter the output of each phase can be connected to either the positive pole, the midpoint or the negative pole of the capacitor. The DC side of the converter is floating, or in other words, insulated relative to ground. Using PWM, the converter will create a very smooth phase current, with low harmonic content. The three-level topology also gives low switching losses. This means high converter efficiency and high current capability.

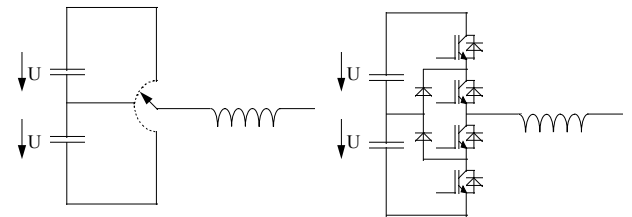

Fig. 7a The principle of a 3-level converter Fig. 7b Neutral Point Clamped converter (one phase)

The three-level converter used is a so called Neutral Point Clamped (NPC) configuration. This configuration includes four IGBT valves and two Diode valves in every phase leg. The DC capacitor is divided into two series connected branches. The different valves are built by stacking the devices on top of each other (between coolers) and by applying an external pressure to the stack.

The IGBT valves are water cooled using ABB Power Systems well proven system with deionized water. Water cooling gives a compact converter design and high current capability. Besides customer benefits, a compact design also has another advantage. This means that the loop inductance between the IGBT valves and the DC capacitors can be kept low, which is beneficial from a loss point of view. In the Hagfors installation the valves are designed to handle approximately 1300 Arms phase current continuously and at transient conditions 1700 Arms.

ABB Power Systems are now ready to deliver SVC Light for direct connection to voltages up to 36 kV AC.



Fig. 8. Photograph of IGBT stacks.

MACH2, the control and protection system

To fulfill the requirements regarding very fast and extensive data processing, ABB Power Systems has developed the MACH2 control and protection system. It is based on industrial standard PC hardware (operating system Windows NT) to facilitate an open system easily integrated into existing systems at the steel works and externally accessed directly if desired.

The strategy of building the control and protection system based on open interfaces assures that future improvements in the fast developing field of electronics can be used. The system consists

basically of three units, the Main Computer, the I/O rack, and the VCU (Valve Control Unit). See Fig.9 below. The communication between the units is performed via industrial standard type busses.

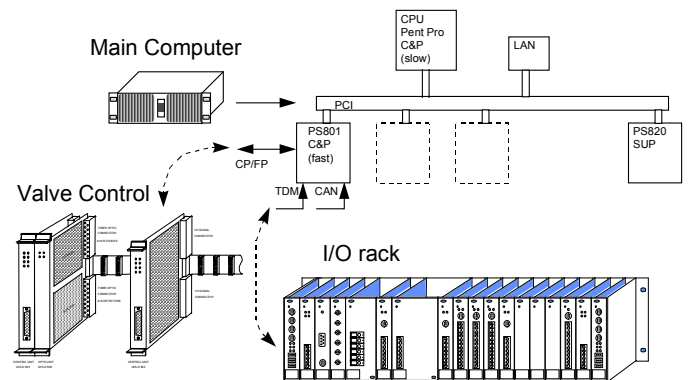

Fig. 9. MACH2 for SVC Light.

The system is operated from an OWS (Operator Work Station), which can be a standard PC. The MMI (Man Machine Interface) is the world's most used graphic control package for Windows NT - InTouch. InTouch is a flexible software, in which special customer adopted MMI can easily be designed.

MITIGATION OF HARMONIC, TRANSIENT, AND NEGATIVE PHASE SEQUENCE DISTORTION

The possibility for the SVC Light to "follow" the stochastically varying furnace current gives an enormous opportunity to reduce voltage flicker. However, with its quick response, also other unpleasant disturbances can easily be reduced. The recording below shows the initial operation of the SVC Light when paralleled to the EAF in Hagfors

steel works. Signals show the SVC Light ability to track the rapid changing of the furnace current.

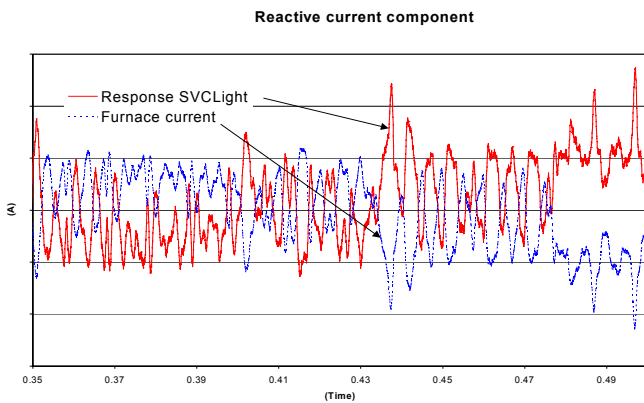

Fig. 10. Tracking of rapid changes of the EAF current.

Harmonic filtering

Very often harmonic generations from Electric Arc Furnaces are of a great magnitude. Large amounts of harmonics could create unwanted heating of machines as well as resonance problems.

The SVC Light concept offers an active filter where depending on the application harmonics up to the 11:th order would be damped. With an active filter, the risk of dangerous parallel resonances between network components will be minimized.

Fast transients damping

With a switching frequency higher than 1 kHz, even fast transients can be damped. In some installations switching transients from a furnace transformer could for example lead to unexpected problems. With the SVC Light technology, the furnace operation with all switching transients will

be compensated. The recording below shows the inrush current of the furnace transformer in Hagfors and the SVC Light output current response.

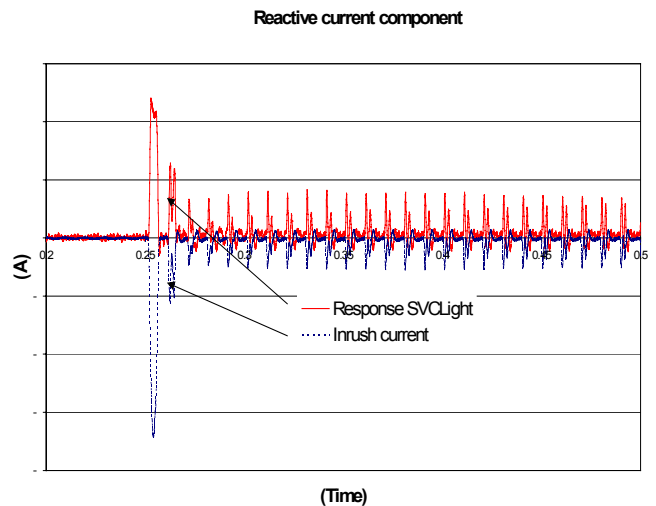

Fig. 11. Inrush current of EAF transformer and SVC Light output current response.

Load balancing

For several reasons it is desirable that the load is shared equally by the three phases of the AC system. Too much unbalance may have disturbing or even damaging effects for example on generators or other rotating machines. With the traditional SVC or new SVCLight concept, the system will from the network be balanced in all three phases.

POWER FACTOR CORRECTION: ECONOMIC BENEFITS FOR THE OPERATOR

Since SVC Light is a reactive power compensator, it can also be used to benefit for power factor correction in the steel plant. Its dynamic response ensures that the power factor can

be kept high and constant under strongly varying conditions of reactive power demand of the plant. This yields valuable benefits for the owner of the plant, not only in the way of minimized billing for reactive power, but also in a decrease of active system power losses.

Also, the minimizing of reactive power flow through the plant brings about a very important stabilization of the EAF bus voltage at a high level, which means that more active power can be taken out of the furnace than otherwise. This can be capitalized on by means of increased furnace productivity as well as lower specific production costs (electrode consumption, etc.).

A concrete increase of active power output of the EAF has in fact been demonstrated in the Hagfors case, please see under “Field measurements” below.

PRELIMINARY FLICKER FIELD MEASUREMENTS

Field measurements have been performed in order to evaluate the performance of the SVC Light at Hagfors site. So far, the measurements have mostly been focusing on flicker.

Investigations at site show that the installed auxiliary current transformer in the EAF circuit has too small a power rating. The low rating leads to saturation during the bore down period of the melt. This problem will be corrected, however at this stage no flicker measurements with a correct CT are present.

The recordings and evaluation presented below show flicker mitigation of 3.4 times. The flicker mitigation is expected to increase to a factor around 4.5 to 5.0 times when new auxiliary transformers have been installed.

The flicker measurements have been performed according to the UIE/IEC method. The method is well known in Europe, Canada, South America and South Africa and is also getting more common in the United States.

The bar chart (Fig. 12) shows flicker generation from the EAF with and without SVC Light. The chart also shows when the furnace is in operation.

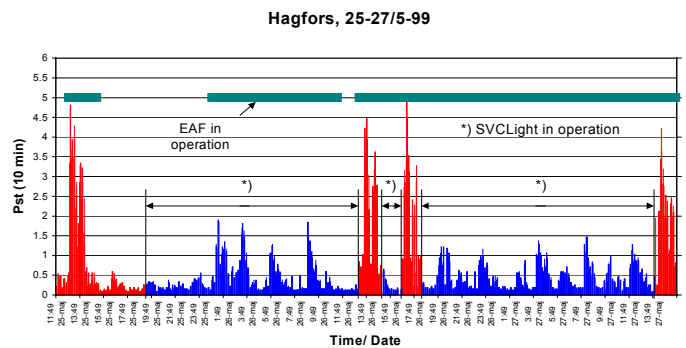

Fig. 12. Flicker generation with/without SVC Light.

Statistical evaluation

In order to evaluate flicker generation with and without SVC Light a statistical evaluation has been performed. The figures below show histograms for the following three cases:

Figure 13a: Furnace in operation, without SVC Light. $Pst(95\%) = 3.90$ p.u.

13b: Furnace in operation, with SVC Light. $Pst(95\%) = 1.21$ p.u.

13c: Background flicker generation. $Pst(95\%) = 0.41$ p.u.

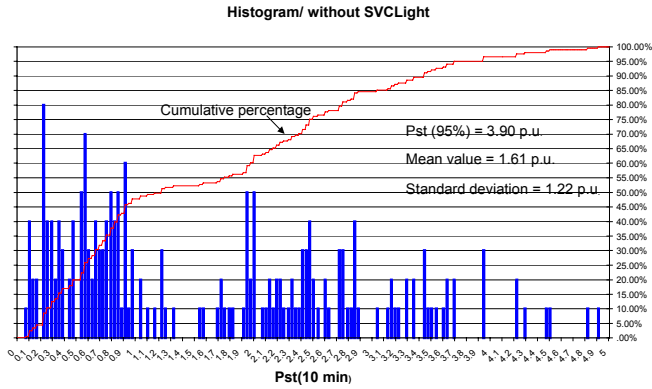

Fig. 13a. Flicker generation without SVC Light.

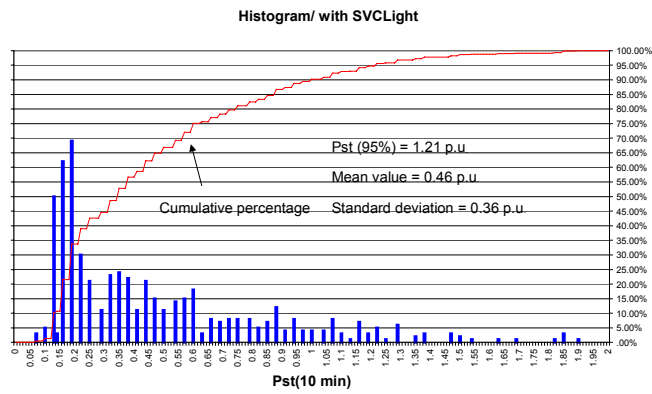

Fig. 13b. Flicker generation with SVC Light in operation.

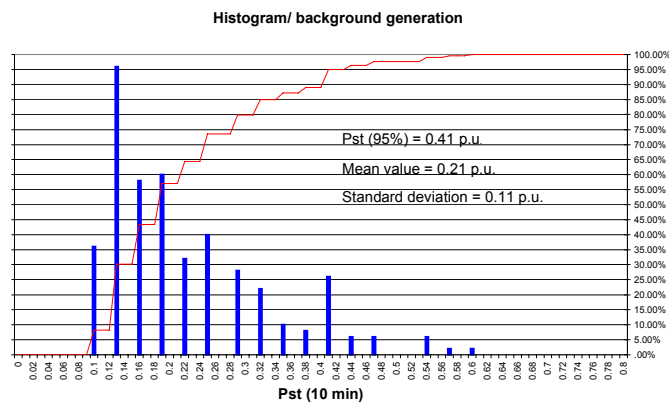

Fig. 13c. Background flicker generation.

According to the UIE (International Union For Electroheat), the recommend praxis to evaluate flicker severity from multiple sources is per the following formula:

$$P_{ST} = \left[\sum_i (P_{STi})^m \right]^{1/m}$$

where m is the summation coefficient.

The summation coefficient considers the risk of coincident furnace operation. The factor is recommended to vary from 1 up to 4. m=4 is used, when furnaces specifically run in order to avoid coincident melts. m=1 is used when there is a very high occurrence of coincident voltage changes.

The background flicker is generated by many sources, and will therefore appear more or less constant over the day. To deduct the background flicker, an “m” factor of 1 should be used. However to perform the evaluation in a very conservative way, a factor of two is used.

In the case of flicker generated by the EAF only and without background flicker, we get with no SVC Light in operation:

$$P_{STA} = \left[(P_{ST1}^2 - P_{ST3}^2) \right]^{1/2} = \left[(3.90^2 - 0.41^2) \right]^{0.5} = 3.88 \text{ p.u.}$$

The residual flicker value with the SVC Light and EAF in operation and without background flicker is:

$$P_{STB} = \left[(P_{ST2}^2 - P_{ST3}^2) \right]^{1/2} = \left[(1.21^2 - 0.41^2) \right]^{0.5} = 1.14 \text{ p.u.}$$

The flicker mitigation by the SVC Light is:

$$R_{SVCLight} = \frac{P_{STA}}{P_{STB}} = \frac{3.88}{1.14} = 3.4 \text{ p.u.}$$

Increased furnace power

An arc furnace requires a stable voltage supply for optimum performance. An SVC Light can instantaneously compensate the random reactive power variations, and hence the voltage variations, of an EAF.

Reactive power compensation by an SVC Light or an SVC helps to obtain the following production benefits:

A higher and stabilised voltage level at the furnace busbar, giving:

- Shorter melt down times
- Reduced energy losses
- Reduced electrode consumption.

Fig. 14 shows measurements of the active power consumption in Hagfors without and with dynamic compensation.

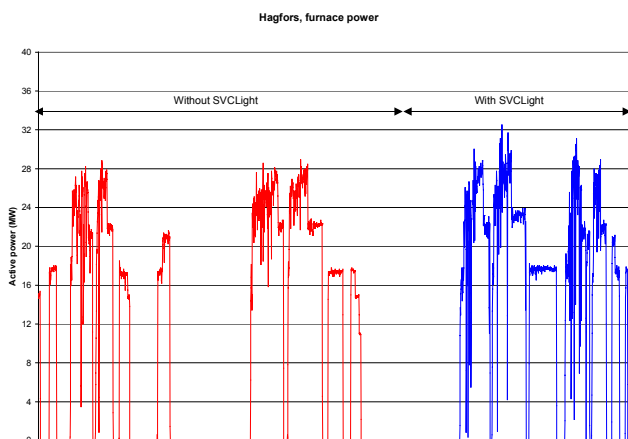

Fig. 14. Active power consumption at Hagfors without and with dynamic compensation.

Through dynamic compensation, the voltage on the furnace busbar is stabilised. The stabilised voltage increases the available furnace input power, Fig. 14.

SUMMARY

The appearing of continuously controllable semiconductors capable of handling high currents and voltages has opened up for a wholly new class of highly dynamic power electronic devices. Voltage source converters far into the tens of MVA range with high dynamic response based on IGBT technology are now a reality. An important as well as sophisticated application for this new technology is mitigation of severe voltage flicker from electric arc furnaces.

An SVC Light, a full scale installation for flicker mitigation based on IGBT equipped voltage source converter equipment has been implemented in a steel mill in Sweden. As an additionally valuable benefit, the available melting power of the electric arc furnace has been increased.

REFERENCES

1. B. Bijlenga, R. Grünbaum, and Th. Johansson, "SVC Light – a powerful tool for power quality improvement", *ABB Review*, No. 6, 1998.

