

## Eagle Pass/Piedras Negras BtB Light



Eagle Pass is a community across the US/Mexico border with Piedras Negras, Coahuila. Eagle Pass load is served by two 138 kV transmission lines and due to load growth the area is prone to voltage instability following transmission contingencies during peak load periods, reducing the reliability of power delivery on the U.S. side of the border.

During emergencies, power for the Eagle Pass distribution network can be brought in from Mexico over a 138 kV line to the CFE grid, but making the connection involves a „block over“ switching operation at the substation, which briefly interrupts power delivery to customer loads.

To mitigate possible voltage instability and at the same time allow power exchange in either direction between the U.S. and Mexico without first having to disrupt service to distribution system customers, an ABB Back-to-Back Light installation rated at 36 MVA at 138 kV has been installed and commissioned in the Eagle Pass substation owned by Central Power and Light Company (CPL), a subsidiary of American Electric Power Company (AEP). The project was executed jointly by EPRI, AEP, and ABB. Preceding this, a couple of options were investigated.

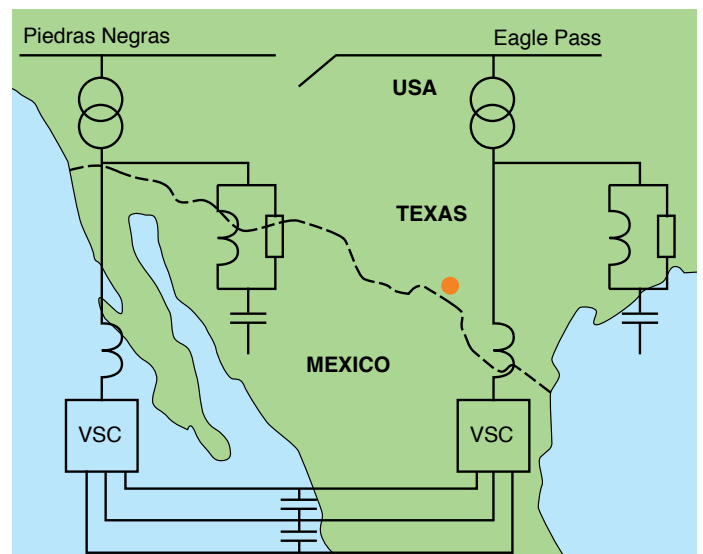

Eagle Pass BtB Light 138 kV, 36 MVA.

The first option assessed was the construction of a new 70 km, 138 kV transmission line into the area, adding to the two existing 138 kV lines serving the Eagle Pass area from Asherton and Hamilton Road substations. The second option was building an asynchronous Back-to-Back interconnection link between the USA and Mexico sides of the Eagle Pass substation, enabling voltage support for the area and allowing immediate import of power into the area from Mexico without any need for building new lines.

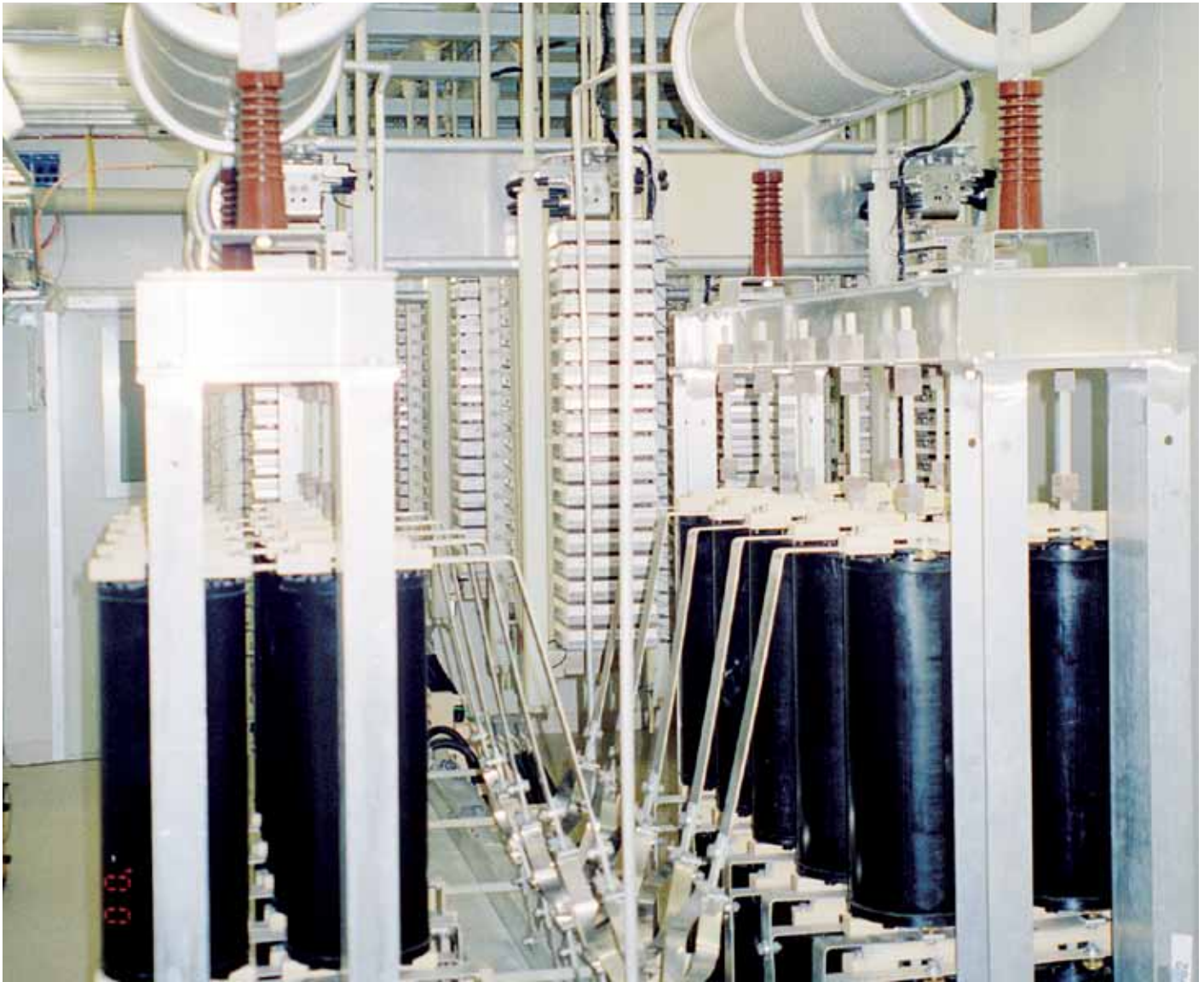

Converter module.

### Eagle Pass Back-to-Back Light Tie

A Back to Back Tie based on the use of Voltage Source Converters, "BtB Light", a technology developed by ABB, was the chosen solution. This choice was made since the alternative would have been much more expensive, and building a new line would have faced the added impediment of having to overcome difficulties in acquiring the necessary rights of way. Furthermore, should a conventional BtB interconnection have been considered, there were concerns that such a solution might not provide the necessary level of reliability because of the weakness of the AC system on the U.S. side of the border.

A BtB Light, however, would not be affected by such weakness since it does not require any voltage support from the interconnected AC system.

The BtB option offers additional benefits as it allows an interchange of power between USA and Mexico in both directions under open access without interfering with the surrounding system, enabling the parties to trade electricity with each other in a mutually beneficial way. BtB Light furthermore adds value to system performance as it acts not only as a link for active power transfer but also, when required, offers dynamic compensation of reactive power in the AC systems on either sides of the link, thereby safeguarding voltage stability in the AC systems for various operating conditions.

### Tie features

Back-to-Back Light is based on Voltage Source Converter (VSC) technology, using IGBT (Insulated Gate Bipolar Transistor) as a solid state switch and Pulse Width Modulation (PWM) switching technique. The combination of IGBTs and PWM technique provides a simple and compact structure in addition to great control and operation flexibility. Furthermore, it does not dictate a need for a specifically designed magnetic interface with the transmission systems on the U.S. and Mexico sides. The Tie is rated at 36 MVA at 138 kV. It comprises two VSCs coupled with a DC link. Each converter is connected to the respective AC grid via air core phase reactors, two shunt (6 Mvar) high pass filters, and a stepdown transformer.

The use of IGBTs in the Eagle Pass BtB VSCs enables high performance with a simple converter topology. IGBTs can easily be series connected without the need for voluminous snubber circuits, enabling a converter voltage rating of  $18 \text{ kV}_{\text{RMS}}$ . This allows for utilization of conventional switchgear equipment in the BtB Light, as short circuit levels are kept low.

The use of PWM with a switching frequency around 1.5 kHz safeguards low harmonic content in the converter output. Also, the IGBT is inherently current limiting in its action, a fact that allows for simplification in the converter design. And

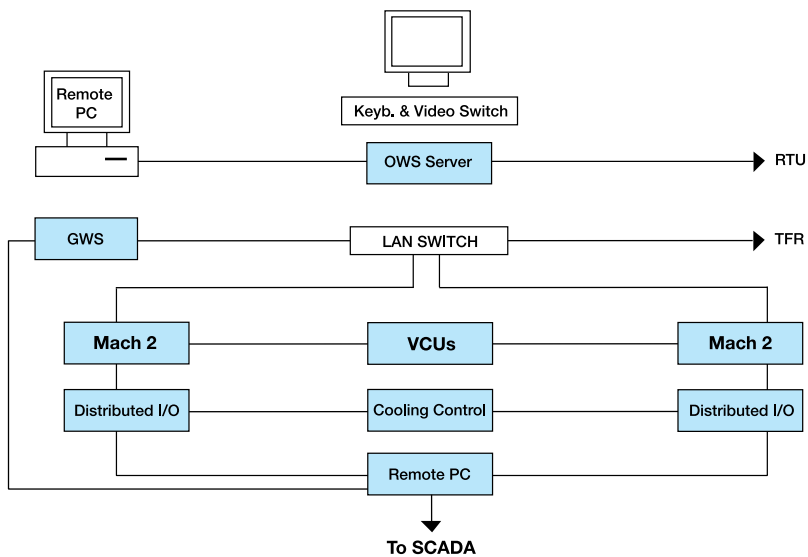

- CONTROL SYSTEM SCHEME**
- OWS Operator Work Station
  - RTU Remote Terminal Unit
  - GWS Gate Way Station
  - LAN Local Area Network
  - TFR Transient Fault Recorder
  - VCU Valve Control Unit
  - SCADA Station Control and Data Acquisition System

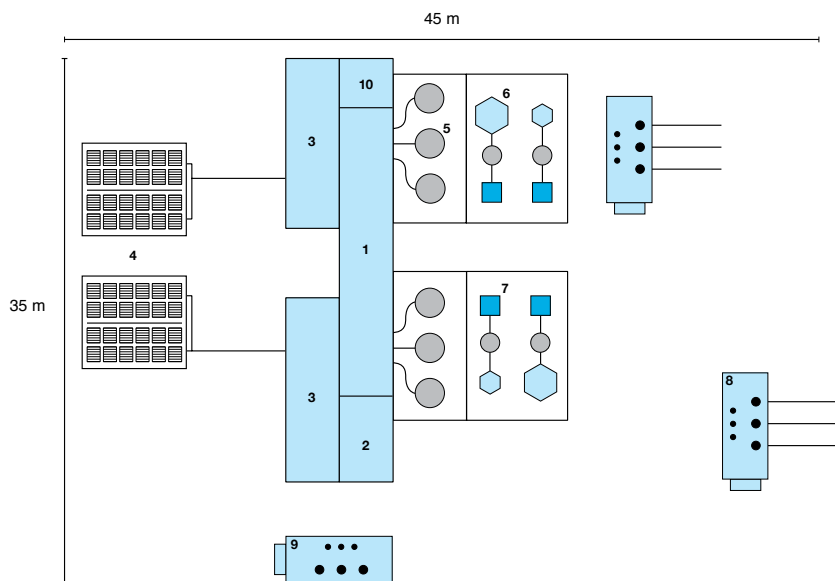

- PLANT LAYOUT**
- 1 IGBT valves
  - 2 Control and protection
  - 3 Auxiliary and cooling pumps
  - 4 Cooling towers
  - 5 Reactors
  - 6 Resistors
  - 7 Capacitor banks
  - 8 Power transformers
  - 9 Spare power transformer
  - 10 Remote interface

finally, the small gating power required in IGBTs also contributes to a compact and robust converter design.

### Control and protection

The control and protection system is to a high degree based on a state of the art industrial PC platform. The control platform, MACH 2, is common for ABB FACTS and HVDC applications. Comprehensive use is made of international industry standard serial communication interfaces to local I/Os and to an RTU for remote access. The control and protection is fully redundant.

The operator interface is also PC based. Normally, control is performed from a remote dispatch centre.

The BtB Light protection is fully integrated into the MACH 2 controller. Conventional protection algorithms are used for the HV switchgear and the stepdown transformers, while unique protection schemes have been developed for the VSC modules and the DC link.

The full integration of control and protection functionality into the MACH 2 controller enables the user to perform on line diagnosis of all critical subsystems in the Tie.

### Modes of operation of the Tie

The Tie provides unprecedented operation capability, controlled bidirectional power transfer and voltage control at the U.S. and Mexico sides. The Tie can be operated either to transfer 36 MW active power, full reactive power support of +36 Mvar (STATCOM functionality) at the two ends of the Tie, or a combination of active and reactive power within the range of 36 MVA.

In STATCOM mode, by a switching arrangement, both VSCs can be connected to either the U.S. or the Mexican 138 kV grid (then isolated from each other), and perform as one  $\pm 72$  Mvar reactive and voltage control STATCOM.

### Station layout

The BtB Light is housed in four standard modular enclosures, docked together on site. There is one module for each VSC, one module for the control room and one for auxiliary systems. The water to air heat exchangers for the VSC cooling system is located outdoors together with the high voltage switchgear.

For more information please contact:

**ABB AB**

**FACTS**

SE-721 64 Västerås, Sweden

Phone: +46 21 32 50 00

Fax: +46 21 32 48 10

[www.abb.com/FACTS](http://www.abb.com/FACTS)