

SVC for improvement of power supply to mining complex

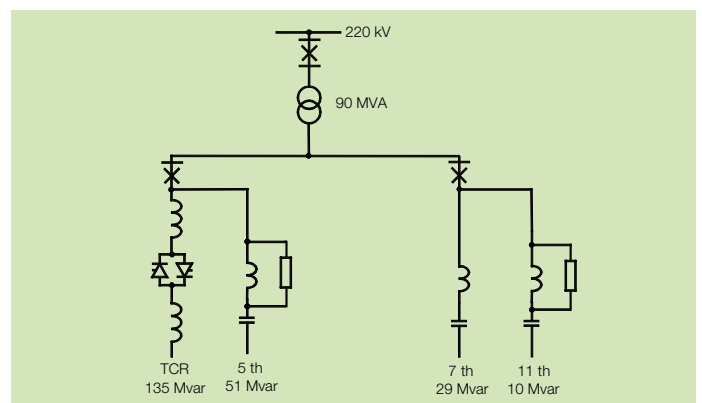

Compañía Minera Antamina is a major mining enterprise in the Andes mountains in North Central Peru, one of the largest producers of copper and zinc in the world, situated at an altitude of more than 4.000 meters above the sea level. The mining complex including the concentrator went into operation in 2001, with a daily production volume of 70.000 tons of ore. A prerequisite for this was the development of an adequate utility infrastructure to feed the mine complex, as detailed electrical studies by the owners indicated that the grid system would be inadequate to support the forecasted loading and several system configurations. In said studies were various alternatives, all of which, for one reason or another, were either too expensive, or were not allowed, due to ROW permitting. Compañía Minera Antamina chose to implement FACTS to improve the existing 220 kV power system at the junction point of their connection with the interconnected utility. The latter was the most attractive option to assure Compañía Minera Antamina of dependable power under all anticipated utility configurations. Based on the above, the decision was made by Compañía Minera Antamina, who was responsible for the overall mining and electrical project, to install a Static Var Compensator (SVC) in the existing 220 kV switching substation at Vizcarra some 50 km away from the mine at an elevation of 3.600 meters. The SVC, supplied by ABB under a purchase contract with Bechtel Corporation, was placed in service in 2001.

The selected SVC is rated at 45 Mvar inductive to 90 Mvar capacitive at 220 kV. Its purpose is to stabilize the 220 kV bus voltage at the Antamina mine substation to within $\pm 5\%$ permitting the operation of very large machinery even under the most restrictive power system configuration. The SVC and power system were designed for a maximum load of 120 MW, of which the largest loading (approximately 70 MW) consists of four cycloconverter drive mills at the concentrator complex. Additional drives for crushers and mine operations consist of variable speed drives and solid state equipment.



Single-line diagram

The design of the SVC took into account various scenarios of power transmission. Without the SVC, power disturbances such as lightning and ground faults on the 220 kV grid may cause load shedding due to the close voltage tolerances that the cycloconverter drives of the mine have to operate at. With the SVC in operation, as long as the grid disturbances do not occur close-in to the SVC, the risk of load shedding is reduced. The SVC provides reactive power support of the AC transmission system in order to maintain a stable voltage during steady state and transient conditions. During transient and fast changing voltage conditions, the SVC helps prevent extreme over-voltages, voltage collapse and instabilities in the system.

Main system design

The SVC comprises a Thyristor-controlled reactor (TCR) rated at 135 Mvar plus an array of Harmonic filters rated at 90 Mvar and comprising three parallel branches tuned to the 5th, 7th, and 11th harmonics. The filters also have the task of generating the reactive power required at network frequency for the proper functioning of the SVC. The variable Mvar output from the SVC is achieved by phase-angle control of the TCR.

Control system

The control system is based on the ABB MACH 2 concept, which is a system of both hardware and software, specifically developed for the application. The MACH 2 is built around an industrial PC, running Windows NT Embedded, with add-in boards and I/O racks connected through standard type field busses like CAN and TDM.

The main objective of the control system is to keep the HV bus voltage close to a voltage setpoint, to provide dynamic, fast response reactive power following system contingencies, and to maintain the magnitude of dynamic system voltages within 110% during disturbances. The voltage control used is a closed loop system. The automatic control can be switched off and the SVC operated manually. The network characteristic and the SVC characteristic together determine the operating point of the SVC.

The SVC can be controlled from two different locations. Locally, from the SVC control room where there is an Operator Work Station (OWS) based on an industrial computer. The SVC can also be controlled via a remote OWS from the substation control room. In normal operation, the SVC is controlled via the OWS in the substation control building.

For more information please contact:

ABB AB FACTS

SE-721 64 Västerås, SWEDEN
Phone: +46 (0)21 32 50 00
Fax: +46 (0)21 32 48 10

www.abb.com/FACTS

Gain supervisor

The fault level is quite low at the 220 kV point of common coupling. This places special demands on the SVC from a control stability point of view. To safeguard the system from any possible control instabilities, a gain supervisor has been installed in the control system, which automatically supervises the gain and keeps it at an optimum level for all specified values of the grid impedance.

High altitude measures

Due to the very high altitude of the SVC location (3.600 meters above sea level), special measures had to be taken in the design of the SVC. Thus, lengths of insulators were adjusted to accommodate the low ambient air pressure. Pump engines and ventilation installations were adjusted to fit into the ambient conditions, as well.

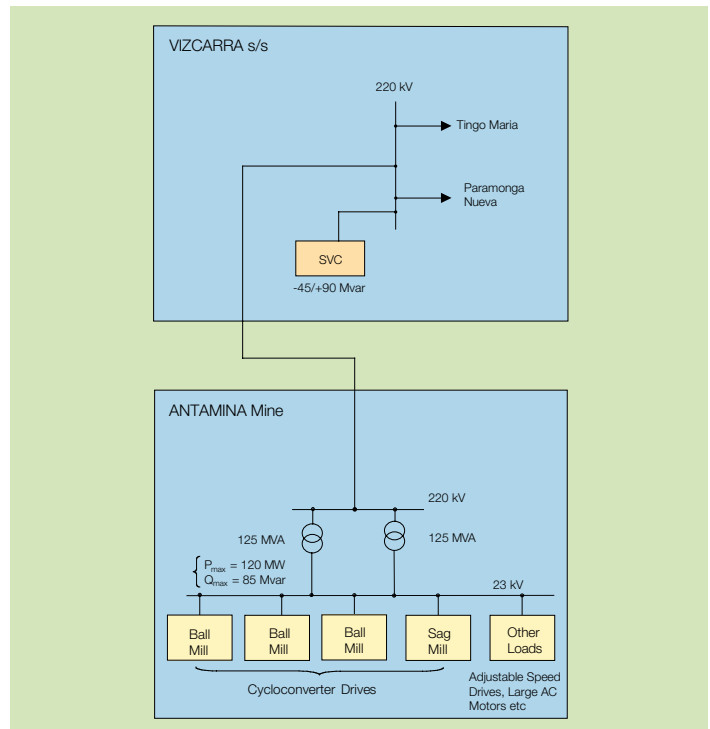

Technical data

Controlled voltage	220 kV
SVC rating	45 Mvar inductive to 90 Mvar capacitive.
Control system	Three-phase symmetrical voltage control by means of a closed-loop regulator.
Thyristor valve	Water cooled, with indirect light triggering.