

## Large scale Offshore Wind Power Energy evacuation by HVDC Light®

Peter Sandeberg, Lars Stendius  
ABB AB  
PSG/DC  
SE-771 80 Ludvika  
Tel: +46 240 78 20 00

### Abstract

With several very large offshore wind farms planned to be built off the coasts of several European countries, new engineering challenges are now being identified. The design, construction and operation of large scale power plant, positioned far out at sea in hostile environments, will require significant skills in the design and construction. ABB has developed a detailed design concept for the completion of the worlds first offshore HVDC Light® Power Plant for integration of large scale wind power production. This paper will highlight the challenges and the solutions met by ABB in the development of this pioneering project.

### Introduction

For well over 100 years HVAC, High Voltage Alternating Current, has been regarded as the natural choice for electrical power transmission. HVDC, High Voltage Direct Current, has been commercial available since the mid fiftieths but has mainly been used for large amount of bulk power point-to-point transmission links over long distances or interconnection of asynchronous grids. However, HVDC, and especially the VSC (Voltage-source converter) based HVDC, is now emerging as a robust and economical feasible alternative offering a superior solution for a number of reliability and stability issues associated with connection of sustainable energy schemes in harsh environments, e.g. offshore wind power applications.

VSC based HVDC transmissions (within ABB called HVDC Light®) are attractive for connecting remotely located (e.g., offshore) wind farms to the main grid. This is partly because the capacitance per length unit makes an ac cable impractical for cable lengths above 50–100 km: a significant amount of reactive power is generated, and low frequency resonances may result in instability phenomena. Moreover, classical thyristor-based HVDC transmissions are less attractive, since a synchronous compensator or a static synchronous compensator (STATCOM) may be required

at the wind farm in order to maintain a smooth line voltage for the thyristors to commutate against. This problem however does not exist for VSC-HVDC transmissions, which use pulse width modulated transistor VSCs with inherent voltage controlling capability.

### VSC HVDC - rectifying, inverting and controlling

With VSC based HVDC, the use of series-connected power transistors has allowed the connecting of voltage source converters to networks at voltage levels hitherto beyond reach. This can be used for power transmission, for reactive power compensation and for harmonic/flicker compensation. With fast vector control, this converter offers the ability to control active and reactive power independently while imposing low levels of harmonics, even in weak grids.

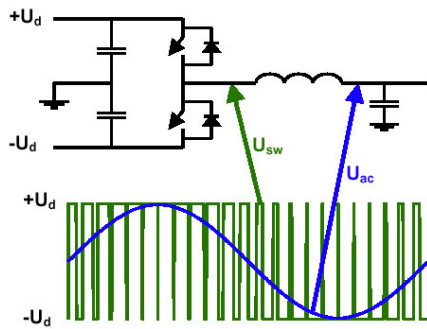

Figure 1 PWM, Pulse With Modulation

In VSC based HVDC, Pulse Width Modulation (PWM) is used for the generation of the fundamental voltage. Using PWM, both the magnitude and phase of the voltage can be controlled freely and almost instantaneously within certain limits. This allows independent and very fast control of active and reactive power flows. Pulse Width Modulation based VSC is therefore a close to ideal component in the transmission network. From a system point of view, it acts as a zero-inertia motor or generator that can control active and reactive power almost instantaneously. Furthermore, it does not contribute to the short-circuit power, as the AC current can be controlled.

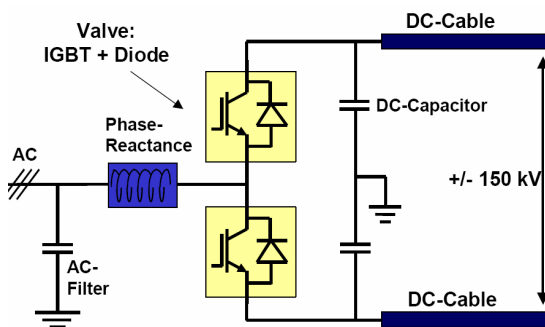

Figure 2 HVDC Light principles

The ABB provided HVDC Light<sup>®</sup> converter design is based on a two-level bridge grounded via a midpoint capacitor. This design philosophy ensures operation, both steady state and dynamic, with extremely low levels of induced ground currents. This feature is one of the critical factors for implementing an HVDC system in an offshore environment. There is no need for

any cathode protection in conjunction with the installation.

The HVDC Light system allows fully independent control of both the active and the reactive power flow within the operating range of the design. Normally each station controls its reactive power contribution (both inductive and capacitive) independently of the other station. The active power can continuously and almost instantaneously be controlled from full power export to full power import. However, the flow of active power in the DC cables must be balanced, which means that the active power entering the HVDC system must be equal to the active power leaving it. A difference in power would imply that the DC voltage in the system would rapidly increase or decrease, as the dc capacitance increases its voltage with increased charge (and vice versa). With a normal design the stored energy is equivalent to around 2 ms power transmission on the system.

To attain this power balance, one of the stations has to control the DC voltage. This means that the other station can adjust arbitrarily the transmitted power within the power capability limits for the HVDC Light system design, whereby the station that controls the DC voltage will adjust its power to ensure that the balance (i.e. constant DC voltage) is maintained. The balance is attained without telecommunication between the stations, quite simply based on measurement of the DC voltage.

### Variable frequency

An HVDC Light converter station normally follows the AC voltage of the connected grids. The voltage magnitude and frequency are determined by the control systems of the generating stations. For a wind power application however, the offshore converter station could control the grid frequency and voltage to a reference value set by an overall wind farm control system in order to optimize the wind power production should such a solution be preferred.

Operation with variable frequency in one end and fixed grid frequency in the other does not require main circuit equipment that differs from the normal design. In general, the design principles adopted for normal

transmission system applications also applies for wind farm applications.

### **Islanded operation**

In case of a voltage collapse, a “black-out”, the HVDC Light<sup>®</sup> converter can instantaneously switch over to its own internal voltage and frequency reference and disconnect itself from the grid. The converter can then operate as an idling “static” generator, ready to be connected to a “black” network. For more information see also section below regarding start up of islanded offshore networks.

### **VSC HVDC Cable - transporting the power**

The HVDC Light<sup>®</sup> concept includes also the extruded polymer HVDC Light<sup>®</sup> cables. It is flexible and cost effective cables that are an important part of the HVDC Light<sup>®</sup> concept.

The cable is designed with a copper or aluminum conductor surrounded by a polymeric insulating material, which is very strong and robust. The water sealing of the cable is designed with a seamless layer of extruded lead and finally two layers of armoring steel wire in counter helix for the mechanical properties of the cable. The strength and the flexibility make the HVDC Light<sup>®</sup> cables well suited for severe installation conditions and deep waters like in the North Sea for example.

### **Going for Wind Offshore - Challenges and Solutions**

It is obvious that there will be a number of more or less tough challenges trying to evacuate large amount of offshore wind power. The aim is to design a very robust electrical transmission with high availability and minimized maintenance meeting not only the strict national grid codes but also to relieve stresses from the wind turbines by isolating electrical transients from the mainland grid. Another, not less important, aspect is of course to design a system that can withstand the harsh and sometimes very hostile offshore climate in the North Sea.

The following sections will discuss some of the challenges met and the corresponding solutions.

### **Offshore environment - Offshore Platform**

Space and weight are scarce resources on offshore installations. Particularly in the light of these constraints, the VSC based HVDC concept offers important advantages; since the filters are small, VSC based HVDC can be made compact and lightweight compared to other solutions. Apart from the obvious needs to make the converter station compact and lightweight, the harsh offshore environment and the remote location places a number of other demands on the converter station and equipment. Examples include:

- Safety for personnel as well as for equipment.
- Salt and humid air imposes severe requirements on the choice of materials and surface treatment.
- Minimized maintenance requirements
- Extensive monitoring facilities

Except for the main transformers all high voltage equipment will be installed inside compact modules at the offshore platform. The ventilation system in the modules has been designed to protect the high-voltage equipment and the electronics from salt laden and humid air. The main circuit equipment is therefore exposed to lower environmental requirements than a normal outdoor installation which allows for a more compact design. The ventilation has also to consider the airborne losses. An advantage of being offshore in the North Sea is of course that cold (5-11 °C) water for cooling is readily available.

The design of HVDC Light permits the Converter Stations to be operated remote or unmanned. The HVDC Light maintenance concept is based upon the objective to keep a very high performance of the link throughout the whole operational lifetime. The estimated annual maximum energy unavailability due to scheduled maintenance is about 0,4% or approximately 35 hours. The annual maintenance can be performed at the most convenient time for the Owner.

The MACH 2 control system and its auxiliary systems have an inherent extensive internal monitoring system built into it. This means that the status of the

system can be continuously monitored also from a remote location.

### Meeting strict Grid Codes

As wind penetration increases the Grid codes requirements have become stricter. Ride-through of voltage dips down to 15% of the nominal voltage—or even zero voltage—for up to 150 ms is today often required. It is also anticipated that requirement for frequency response, i.e., that the wind farm output power should be increased as the grid frequency decreases and vice versa, will be imposed. Frequency response can be introduced in a wind farm connected via an HVDC Light<sup>®</sup> transmission by maintaining a telecommunication link between the main-grid-side (onshore) and wind-farm-side (offshore), where, among other variables, the instantaneous main-grid frequency is transmitted. Since the voltage at the wind-farm bus is fully controllable (amplitude, frequency, and phase) by the rectifying VSC, the grid frequency can be “mirrored” to the wind-farm grid without significant delay.

Neither is ride-through of voltage dips due to faults at the rectifying VSC, i.e., in the wind-farm grid, difficult. By closed loop control, the converter current is kept within its prescribed limits, which allows the VSC-HVDC transmission to remain on-line until the fault is cleared.

Ride-through of voltage dips at the inverting VSC, i.e., in the main grid, is, on the other hand, more challenging. A reduced main-grid voltage implies that the power transmission capability is reduced by a similar proportion, due to the current limit of the inverting VSC. For example, for a dip down to 15% of the nominal voltage, only 15% of the transmission capability remains. In a “standard” HVDC Light<sup>®</sup> transmission connecting two utility grids, a similar scenario is solved by instantaneously reducing the input power of the rectifying VSC through closed-loop current control. In a strong grid with an amount of generation much greater than the rated transmission capability, this will occur without a significant change in the voltage. The characteristics of a wind farm are, however, different. The wind-farm network is much smaller than the typical utility grid, and

consequently weaker. Also, its rated generation normally matches the rated HVDC transmission capability. A fast reduction of the input power of the rectifying VSC may therefore lead to a significant increase of the wind farm bus voltage resulting in an over voltage tripping of the VSC and/or the wind turbines. In principle, there are two methods to overcome this problem:

1. Signal to the WTGs via the wind-farm grid voltage that their output power should be reduced as quickly as possible.
2. Use a chopper solution to dissipate the excess energy that cannot be transmitted by the inverting VSC.

Complicating the first solution are two facts. Firstly, the total dc capacitance (sum of the capacitances installed in the VSCs and the cable capacitance) is normally small; if power transmission is interrupted, the dc voltage may reach an unacceptably high level (typically, the protection action level is set at an over voltage of about 30%) in a period of only 5 to 10 ms. The WTGs must therefore be able to both detect that a power reduction should be made *and* reduce the output power (possibly to zero) within this time frame, which may be quite demanding. Secondly, the response of WTGs to a varying voltage is generally not the same for the main WTG types: fixed-speed induction generators (FSIGs), doubly-fed induction generators (DFIGs), and full-converter generators (FCGs). However, since it is possible that different WTG types may be used within a certain wind farm, it is desirable that the ride-through strategy selected should be general for all WTG types.

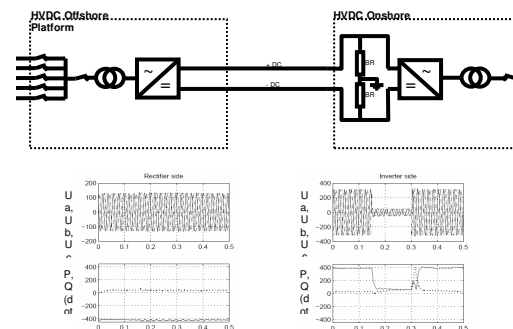

Figure 3 HVDC Light<sup>®</sup> with chopper solution

The latter solution is very robust, and leaves the wind farm unaffected during main-grid faults. The dc chopper is a resistor in the dc-circuit with high energy capability. The dc chopper evacuates the surplus of energy during network faults, when a power transmission is not possible. Therefore, there will be no abrupt change in the output power from the wind turbines and the disturbance seen by the wind turbines will be minimized.

One can also anticipate a lot of positive side effects with such a solution as the HVDC link together with the chopper will make the wind farm “immune” against electrical transients thereby eliminating the mechanical stresses originating from the electrical side that may arise on the equipment in the nacelle, e.g. gearboxes.

#### **Starting up of and islanded offshore network – Black Start**

The ability of the HVDC Light® converters to generate a voltage that can be changed very quickly in amplitude and phase, offers the possibility of energizing a network after a blackout. This is especially useful when it comes to energization of an offshore network. The converter transformer will be equipped with a special auxiliary power winding for self-supply of the converter station, and the control system will have special schemes for detecting a network blackout. If such an event occurs, the converter will automatically trip the connection to the grid, and continue to operate in “house-load” operation, supplied through the DC cables from the mainland grid. The converter can also be started manually in Black-start mode, if needed. The network restoration sequence starts with the offshore station running without load. The voltage and frequency are decided by the converter, which in this case operates in frequency control mode as a generator. The AC-voltage can be smoothly ramped up by the VSC thereby preventing transient over-voltages and inrush currents. The WTG:s can be automatically connected to the offshore network after seeing the correct AC-voltage for a certain time.

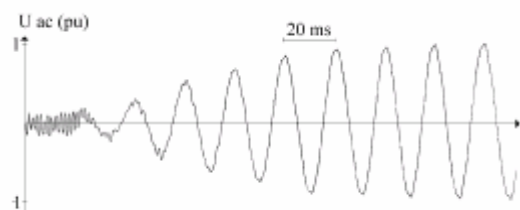

*Figure 4 AC voltage at start-up of an isolated network (measurements from the Hällsjö project)*

#### **Offshore Commissioning**

Considering HSE (Health, Safety and Environmental) aspects for the personnel and also from an economical point of view the number of man-hours offshore shall try to be minimized. For this reason an extensive commissioning program of the offshore station will take place at a nearby harbor before shipping the modules to the offshore site. This will not only be more convenient and safer for the personnel but will also mean increased quality and ensure fast and effective commissioning at the offshore platform out at sea.

#### **Future Power Transmission for Offshore Wind**

With several gigawatts of offshore wind generation in Europe now in the advanced stages of planning, the demand for reliable and robust power transmission to shore is now a fact.

The design, construction and operation of large scale power plant, positioned far out at sea in harsh environments, will require significant skills in the design and construction. ABB has developed a detailed design concept for the completion of the worlds first offshore HVDC Light® Power Plant for integration of large scale wind power production. The valuable lessons learned by engineers and briefly highlighted in this paper may help to reduce the technical and hence financial risks faced by offshore wind farm developers currently considering alternative designs for the connection of future very large offshore renewable energy projects.

## References

[1] D Wensky et al.: "FACTS and HVDC for grid connection of large offshore wind farms", *EWEC conference 2006*.

[2] A.-K. Skytt, P. Holmberg, L.-E. Juhlin: "HVDC Light for connection of wind farms", *2nd international workshop on transmission networks for offshore wind farms*, Royal Institute of Technology, Stockholm, 2001.

[3] L Harnefors et al.: "Ride-through methods for wind farms connected to grid via a VSC HVDC transmission"

[4] P Jones, Bo Westman, "From Generation to grid", *renewable energy focus*