

PROTECTION AND SUBSTATION AUTOMATION SYSTEMS: STANDARDIZATION, INTEGRATION AND INFORMATION TECHNOLOGY

I. De Mesmaeker
ABB Switzerland Ltd.

Bruggerstrasse 72
CH-5400 Baden, Switzerland
Phone: +41-58-5855859
Fax: +41-58-5853324
Email: ivan.de_mesmaeker@ch.abb.com

C. Ryttoft
ABB Power Technologies
Management Ltd.

Affolternstrasse 44
CH- 8050 Zürich, Switzerland
Phone: +41-433175236
Fax: +41-433175238
Email: claes.rytoft@ch.abb.com

P. Reinhardt
ABB Switzerland Ltd.

Bruggerstrasse 72
CH-5400 Baden, Switzerland
Phone: +41-58-5853636
Fax: +41-58-5853324
Email : petra.reinhardt@ch.abb.com

Abstract – *The profitability pressure on utilities as a consequence of market liberalization and other influences is leading to the reconsideration of the entire secondary technology inside the substation. Possible synergies between protection, control and monitoring have to be considered. At the same time, assets have to be used in a more efficient and profitable way and an increased security of energy delivery is required. This is mainly due to the rising costs of non-delivery of electrical energy as well as the negative impacts of blackouts, but also to consumer demands and public opinion. The contribution addresses how protection and substation automation systems can contribute to a substantial reduction of costs and analyses the possible levels of integration, various standardization aspects, the information technology (mainly IEC 61850) as well as the overall system protection scheme (wide area monitoring, control & protection).*

1. INTRODUCTION

The business environment for utilities has changed drastically also due to the restructuring of the electrical energy market. The resultant profitability pressure leads to the reconsideration of the entire secondary technology and especially to the utilization of possible synergies between protection, control and monitoring. To reach a cost optimization, several issues have to be addressed:

- The secondary technology itself considering mainly the effects of integration and standardization
- The maintenance issues mainly taking the impacts of the standard IEC 61850 into account
- The system behaviour (failure or blackouts) considering mainly the impact of wide area protection, control and monitoring.

The field of protection and substation automation technology has been and still is changing dramatically. Whilst the electromechanical or steady-state technology was based on a “one device – one function” approach and led to the maintenance of a strict separation between protection, control and monitoring applications, the use of numerical technology provides multifunctional equipment with serial communication and leads to data exchange across all applications. The introduction of this technology into control and protection imposed the reconsideration of secondary technology concepts in substations. Experiences gained since the introduction of serial communication using proprietary

protocols for the communication and control of installed IEDs (Intelligent Electronic Devices) has led users to request an open protocol for all functions like protection, control and monitoring, at least inside the substation. Open means e.g. to have the possibility to realize extensions without being dependant on the manufacturer having previously delivered parts of the substation equipment. It also means that third-party equipment should be easy to integrate into the system of any manufacturer.

The numerical technology facilitates the development of new solutions as well as higher degrees of integration. This in combination with the advances in information technologies contributes to greater efficiency in network management and leads to reduced outages, optimized utilization of the substation assets, better fault analysis as well as higher quality of the monitoring functionalities, all together resulting in a reduction of costs.

Therefore four main issues have to be handled accordingly:

- The level of integration
- The standardization aspects
- The information technology
- The wide area monitoring, control and protection system.

2. LEVEL OF INTEGRATION

The authors show that integration of ever more functions into less equipment is going on for many years already, but the numerical technology accelerated this process and its essential features can be summarized in two main aspects:

- The use of a common hardware platform with the downloading of protection, control and monitoring functions from a software library, instead of strictly dedicated products per function
- The use of the fibre-optical serial communication facilities.

One of the advantages of having a common platform for protection and control is that such functionality as serial communication, event as well as disturbance recording are designed only once for the whole family of IEDs and can be offered to customers on a more cost-effective basis as compared to dedicated equipment

From the technological point of view, the capabilities needed for higher integration are available. An example for a high degree of integration is the decentralized busbar protection

covering also breaker-failure as well as bay-oriented protection functions. In practice, this means that the main 2 bay protection device (e.g. distance protection) is eliminated and the corresponding function is integrated in the bay units of the busbar protection scheme, making it a station protection scheme (Figure 1).

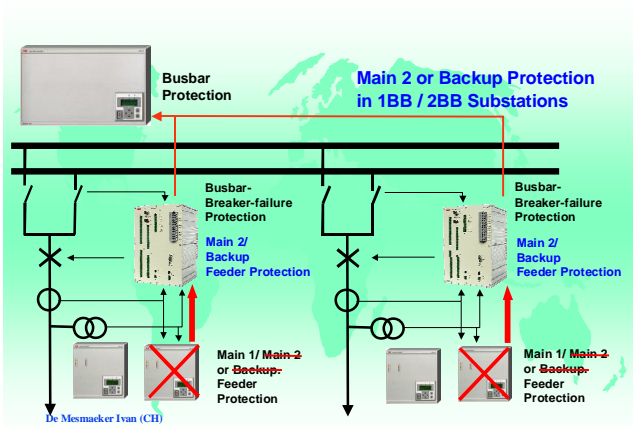

Figure 1: From busbar protection to a station protection scheme.

On distribution level, it is common practice to combine protection and control in one device per feeder at bay level. For higher voltage levels, however, discussions are still going on as to whether such a concept is acceptable. Meanwhile, several utilities have already accepted to go for high integration in transmission networks, using for instance a main 1, a main 2 and a controller (totally 3 devices) per bay (additionally one device in case of a decentralized busbar protection). The technology for an even higher level of integration is available today.

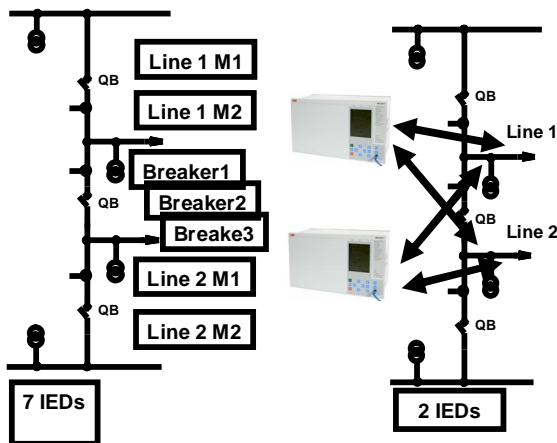

Figure 2: Reduction of the number of IEDs in an one and a half breaker arrangement with two lines.

An example can be presented for the case of an one and a half breaker arrangement: A diameter with two lines can be protected and controlled by only using two IEDs (see Figure 2) instead of 7 devices previously (one controller per breaker and 2 protection devices per line).

This generally implies changes in the organization, taking the experts for control and protection in only one entity inside the company. It also results in a change in the specification, going away from a box approach to describing the real requirements without giving the final solution.

3. STANDARDIZATION ASPECTS

Standardization is covering two main aspects:

- Typical bay and station levels
- Communication

3.1 Typical bay and station levels

Independent of the technology used, it is possible to define the required functionality for each type of bay installed or to be installed in the substations. Such definitions per bay type include the needed functions, the required quality of each function (e.g. tripping times, precision), etc.

Two basic considerations are important for a technically and economically optimal solution:

- Requirements should be functional rather than solution-oriented
- Functionality should be as near as possible to the primary process.

3.2 Communication

With the introduction of serial communication, several standards have been issued but were limited in their fields of application. With respect to openness, a new standard, IEC 61850, was needed in order to:

- Cover all communication issues inside the substation
- Assure interoperability between the functions existing inside the substation (as preliminary condition for interchangeability)
- Support all types of architectures used, e.g. centralized ones similar to RTUs and decentralized ones as used in fully developed substation automation systems
- Support different degrees of integration, e.g. high functional integration at bay level or facility to integrate sensors and actuators via process bus
- Be future-proof, i.e. to cope with the fast development in communication technology in the slowly evolving application domain of power systems.

These are very ambitious goals because all functionality needed in substations had to be examined with respect to its communication behavior and requirements.

3.2.1 IEC 61850: basic approach

The basic approach of the new standard IEC 61850 can be summarized as follows:

- Data model for all functions inside the substation
- Substation Configuration description Language (SCL) for a comprehensive description of the complete SA system supporting the goal of interoperability
- 100 Mbit/s Ethernet network with switches
- Standardized communication mechanisms (services) for all communication tasks:
 - SCADA application in the substation
 - Time-critical information exchange
 - Connection of the primary process.

The standard impacts the whole project execution, from system design to commissioning and maintenance.

3.2.2 IEC 61850: SCADA application in the substation

Supervisory control and data acquisition (SCADA) is one of the basic tasks of a substation automation system. This comprises:

- Local and remote operation of the switchgear and other high voltage equipment
- Acquisition of switchgear information and power system measurands
- Handling of events and alarms.

The SCADA application is related to human operation of the network and is performed by a local or remote operator. The data communication for this application is directed **vertically**, i.e. from a higher hierarchical control level down to a lower one (commands of any kind from the operator's place) or reverse (binary indications like breaker or isolator positions, measurands from instrument transformers and other sensors, events, alarms). It allows to operate and to supervise the power system.

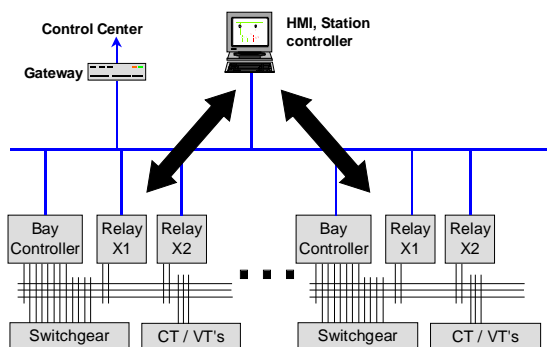

Figure 3: Vertical communication in the substation automation system.

For this vertical relationship, IEC 61850 is using the client - server concept. Here, the server is the local or remote operator's workplace and the clients are the bay level IEDs. In a client-server communication, the client controls the data exchange. Therefore, client-server communication is very flexible in terms of the data to be transmitted. Compared to a master-slave system, the client-server concept facilitates the implementation of multiple clients in the same system. IEC 61850 not only specifies the method of the data transfer. It defines the process data of the servers as well. For this purpose, IEC 61850 uses an object-oriented approach with Logical Nodes (LN) as core objects. This is a functional grouping of data and represents the smallest function, which may be implemented independently in devices. The Logical Nodes, the data and the attributes including their names and semantic interpretation are defined by the standard. Logical Nodes are grouped in Logical Devices and Logical Devices are implemented in physical devices (IEDs).

3.2.3 IEC 61850: Time-critical information exchange

There are several automated functions in the substation automation system, which require a fast and reliable exchange of binary information between functions located within the same bay or in different bays. A typical example is the exchange of information between bays for station interlocking.

These functions are generally not using human interaction and are time-critical, because they are safety-critical. The maximally accepted communication delay is in the range of several milliseconds. If the functions exchanging the information are located in different IEDs, the information exchange may be done using copper wiring with contacts and auxiliary relays or serial communication. This information exchange is mainly a **horizontal** communication between devices at the same hierarchical level.

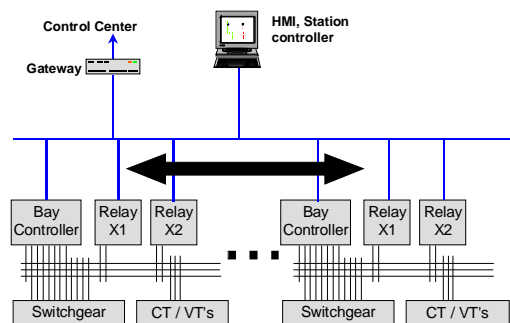

Figure 4: Horizontal communication in the substation automation system with hardwired process interface.

An appropriate communication concept for this purpose is the publisher-subscriber communication. The publisher is

distributing the information via the communication network; the subscriber may receive the information according to its needs. For the exchange of this type of (binary) information over serial communication, IEC 61850 introduces a specific information exchange service called GOOSE (Generic Object Oriented Substation Event) based on the publisher-subscriber concept. The content of a GOOSE message is defined by a dataset. GOOSE messages are sent as multicast messages, which means that multiple devices can receive the message and retrieve the required information from it. The communication service is not confirmed; instead, the message is repeated several times. This use of a reduced communication stack results in a very short transmission time.

3.2.4 IEC 61850: Connection to the primary process

The process connection provides the information exchange between the substation automation system and the high voltage equipment:

- Voltage and current waveforms
- Position and other status information
- Open, close commands and other controls.

The information exchange may be done using copper wiring (e.g. nominal secondary value of 100V/1A for voltage and current waveforms) or using serial communication. For the exchange of voltage and current waveforms using standardized serial communication, IEC 61850 defines the service for sampled value transmission. An important aspect while using sampled values of a power system is the phase relationship between the different measured signals, in particular between current and voltage. IEC 61850 is using the concept of synchronized sampling. All units performing sampling are globally time-synchronized with the required accuracy. Sampled values are transmitted as multi-cast messages receivable by multiple clients.

Solutions based on process bus have been applied by suppliers for some years already. Their real introduction to the market has, however, been very limited, due to the fact that the communication used was proprietary. With the introduction of IEC 61850-9, it can now be expected that solutions based on the process bus will increasingly be used.

3.2.5 IEC 61850: Substation automation design

The standard IEC 61850 has an impact on all activities related to the field of protection and substation automation, but the main issues are how to implement the standard in practice, which is to be done by the suppliers, and how to specify protection and substation automation systems, which is to be done by the users like utilities.

3.2.5.1 Specification

As already mentioned above, some changes in the technologies used for substation automation have been very

important like the use of serial communication and of multifunctional equipment. This implies that the specification should preferably refer to functionality based on the single-line diagram rather than to specific devices.

The standard supports various philosophies and architectures but it is generally advantageous – as mentioned during some CIGRE colloquia – to place the functions as close as possible to the primary process.

Specifying according to the standard IEC 61850 means that the entire functionality is split into Logical Nodes with their corresponding data, i.e. with the established common naming of the function-related signal names.

The standard indicates mandatory and optional data. It is recommended to check the “old” lists with all signals and evaluate which ones are really needed, what purpose they have and which functions they belong to. This is especially important since they may be optional or extended data according to IEC 61850.

As the standard is not defining the quality of the functions, each manufacturer of protection devices still decides by itself which functions can be provided in a device, on the algorithms and performance used and the setting information required by the corresponding tool. Thus, if these parts are important to a user, he or she still needs to add them into the specification by defining the quality of the functions and their allocation to devices. Moreover, acceptable transmission times for data during defined avalanche conditions as well as the availability of the system should also be specified. These parts of a specification do in fact not incur any changes as compared to a previous specification for substation automation meaning that those items are independent of the standard.

3.2.5.2 System implementation

The informal information from the specification has to be translated into a formal description using SCL. This warrants high quality, ensures integrity and consistency during the entire implementation process, from the general system design to the final commissioning, facilitating corresponding checks in each step of project execution.

Based on this approach, the system integrator plays an essential role, especially in the multi-vendor environment possible with IEC 61850. It is responsible for elaborating an optimal solution for the user, taking into consideration not only the direct impact of the standard, but also all boundary conditions indicated in the specification such as geographic arrangement, availability aspects, etc.

When building a system, it is essential that the components used are compliant to the standard IEC 61850. In addition to the device description (a so-called ICD file being the SCL description of the device capabilities), a detailed type-test within a complete system environment is strongly recommended.

Each IEC 61850-compliant IED can be configured using its dedicated tool. With all these IEDs and their respective tools

being compliant with IEC 61850 regarding the standardized data model and data access (services), the system integrator can ensure the integration of third party IEDs into a substation automation system.

The system integrator should be able to indicate references of realized IEC 61850 projects and should deliver an SCD file for its equipment. Whilst the supplier of dedicated components should provide test certificates from a UCA-qualified test laboratory, the system integrator should preferably have access to appropriate testing facilities in order to be able to prove the interoperability and performance of the many components within the system.

3.2.5.3 System documentation and maintenance

Finally the complete substation automation system is formally documented using SCL. This ensures that all engineering work is „memorized“, and allows reuse for adaptations (e.g. introduction of process bus), extensions (e.g. additional bays) and also refurbishment at any time.

4. INFORMATION TECHNOLOGY

The use of communication facilities means that the control and protection systems can fulfil a complementary task: the collection of all available data. The generated information can furthermore be delivered to where it is needed. Protection and control systems are a part of the complete power system management. Inside each substation, bay level equipment fulfils control, protection and monitoring functions and collects data that are transmitted to the station level for monitoring or automation purposes.

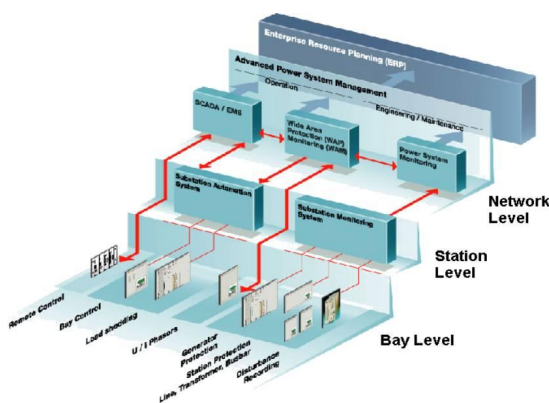

Figure 5: Power System Management.

A lot of information is also dedicated to the enterprise level for resource planning as well as for asset management or maintenance. For example, automatic fault reports can be generated and sent to the persons involved in maintenance, for repair and further analysis. By receiving the information about the short-circuit currents which breakers have already

interrupted, maintenance on demand instead of periodic maintenance can be applied.

With increased utilization of power systems and higher complexity in their operation, the monitoring and protection of bigger portions of the network is gaining importance in order to prevent the spreading of disturbances and even blackouts (see Wide Area Monitoring & Protection in Figure 5). The main aspects of such a Wide Area Monitoring & Protection System are presented in the next chapter.

5. WIDE AREA MONITORING, CONTROL & PROTECTION

Wide Area Monitoring Systems are essentially based on the data acquisition technology of phasor measurement for current and voltage. Time-synchronized phasor measurements including both magnitudes and phase angles are taken by Phasor Measurement Units (PMUs), which are installed at selected locations in the power system. The data are time synchronised via GPS receivers with an accuracy of 1 microsecond and the precision of the phase angle measurement is better than 0.1 degree.

The applications of such a system cover different fields:

- Validation of the network calculation model. The results of the network calculation done by the utilities can be validated and enhanced with the measurements of the Wide Area System
- Network analysis can be improved. During major faults or disturbances in the network, the Wide Area System covers the gap between the information available from single disturbance recordings and SCADA systems. It provides system-wide synchronised data recording.
- Monitoring of particular corridors:
 - Phase-angle monitoring
 - Line thermal monitoring. Comparison tests realized in Switzerland have indicated that the system can be validated for temperature evaluation.
- Voltage stability monitoring:
 - Voltage stability of entire networks with indication of power margin to stability limit
- Power oscillation monitoring
- Frequency stability monitoring.

Figure 6 gives an example indicating the sensibility of such a system. It shows the frequency variation measured in Switzerland and Greece during a disturbance in Spain (loss of 1000 MW generation). The dynamic variation in frequency of 28 mHz was very well registered. Based on such wide area information, power system operators can recognize unforeseen phenomena or disturbances occurring outside their own system. Therefore, they can appropriately counteract any such contingency at an early stage to maintain system integrity.

Today, the Wide Area System can contribute to the optimized utilization of transmission capacities, the maintenance of system integrity and the avoidance of blackouts by giving the right information to network operators in due time.

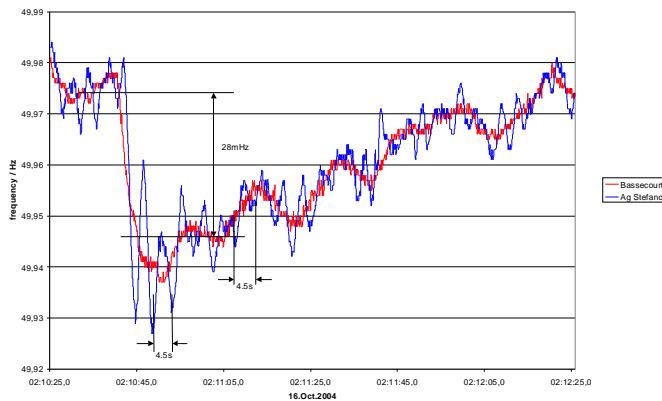

Figure 6: Loss of a power plant in Spain (1000 MW) initiated dynamic system response in Greece and in Switzerland.

6. CONCLUSIONS

Protection, monitoring and control are more and more considered as parts of a system and no longer as independent entities. The specialists involved in these activities will in future cooperate much more closely than in the past. Merging of different departments and activities is a trend, already realized on the manufacturers' side, on-going on the utility side.

The introduction of numerical multifunctional equipment and the use of high communication capabilities change the concepts of substation automation systems. Integration of more functions in less equipment is an on-going process.

The power system management concept with today's information technology opens the door for advanced applications.

Power not delivered will become more costly. This means that the requirements for the protection will increase and the application of wide area systems will become more widespread.

The expectations related to the standard IEC 61850 are very high and utilities around the world are requesting compliant solutions. The standard will also facilitate the introduction of the process bus connecting primary and secondary equipment and enabling metering, control and protection data exchange via IEC 61850-9-2. This will lead to greater flexibility in terms of substation layouts, substation automation system architectures and distributed functions. The main ideas applied during the elaboration of the present standard are now applied to other areas as well, e.g. to the communication between IEDs on both ends of overhead lines.

7. REFERENCES

- [1] „How to use IEC 61850 in protection and automation“
Ivan De Mesmaeker, Klaus-Peter Brand, Christoph Brunner,
ELECTRA 222, October 2005
- [2] „Practical considerations in applying IEC 61850 for Protection and Substation Automation Systems“
Ivan De Mesmaeker, Peter Rietmann, Klaus-Peter Brand,
Petra Reinhardt
2nd GCC CIGRE International Conference, Doha, Qatar,
November 2005