

STATCOM and beyond

Versatile Voltage Source technology for
power transmission excellence

Power and productivity
for a better world™



Introduction

ABB is focused on providing systems and equipment that optimizes the backbone of the electricity industry, – the transmission grid. We strive to be innovative and present ideas that are cost efficient, fault-tolerant and environmentally friendly. We are focused on maintaining our leadership here and one key success factor is to use a versatile technology platform. Such a platform uses state-of-the-art power semiconductors and high voltage apparatuses for a wide range of applications, some described here. The achievements are unique.

Given this background, ABB has launched SVC Light®. It is based on proven Voltage Source Converter (VSC) principles; SVC Light has taken these principles to the transmission and distribution grids. The concept of VSC based reactive power compensation is known as STATCOM within the industry. ABB has branded it SVC Light. More than a dozen installations are already in operation, comprising more than a thousand dynamic Mvar, and serving with pride.



SVC Light: the ABB way

SVC Light comes with unique versatility. Thanks to the unequalled switching speed of the Pulse Width Modulated (PWM) power converters, employing Insulated Gate Bipolar Transistors (IGBT), it provides...

- robust voltage support under severe system disturbances where voltage recovery is critical
- dynamic voltage balancing when the loads are unsymmetrical and rapidly fluctuating
- power oscillation damping capabilities
- improved voltage control under contingencies
- active filtering of harmonic currents

The very nature of the applications is such that SVC Light must perform "under pressure". It must be truly dependable. The design principles chosen for SVC Light are unique and tailored for these extremes. This is where ABB combines simplicity and elegance. The series connection of IGBTs greatly facilitates the configuration of the power circuits and the use of PWM enhances their robustness. The result is a truly unrivalled combination of performance, user-friendly design and high dependability.

SVC Light is characterized by...

- sub-cycle response
- robust algorithms/behavior for/at voltage support, also under unsymmetrical conditions
- compactness, minimum footprint
- high degree of encapsulation, low "emissions"
- high degree of prefabrication

It is worth noting that SVC Light is used to tame the wildest thing found connected to electrical grids, the large Electric Arc Furnace. Several success stories reveal that SVC Light practically eliminates the power quality concerns related to this tremendously violent load. SVC Light truly shines when the going gets tough.

The ABB IGBT



Two sub-module StakPak™ (collector-side up) with an open sub-module (emitter-side up) showing the emitter-side spring assemblies.



IGBT stack

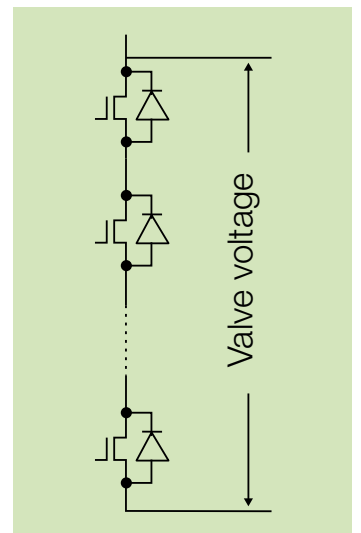

Versatility at last

Active/reactive power capability with SVC Light

SVC Light in its basic form is a device of STATCOM type, i.e. a Static Compensator (of reactive power only). Static by name since it works without any moving parts. Its principal behaviour is that of the Synchronous Condenser, of course without inertia, but with much faster response to disturbances. Its power semiconductors make it the utmost dynamic device, enhancing grid voltage stability and power quality in a truly superior way.

The SVC Light performance focuses on:

- Dynamic Voltage Control in transmission and distribution.
- Power Quality Improvement in transmission and distribution.
- Simultaneous Control of Active and Reactive Power *

Widening the perspective SVC Light can additionally raise the transient and dynamic stability limits of a transmission grid, if controlled to counteract bulk power swings.

Often compared with traditional technologies like SVC and Synchronous Condensers, it becomes apparent that the platform behind SVC Light adds some new dimensions to the concept of power system stability enhancement such as an HVDC link with integrated voltage support capabilities or a Dynamic Energy Storage. More about this on page 10 and 11.

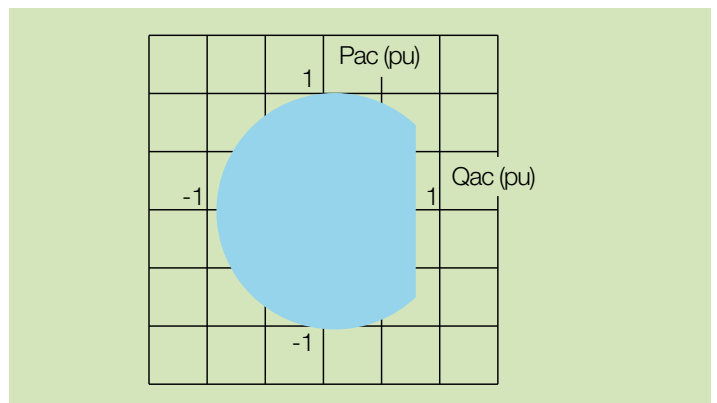
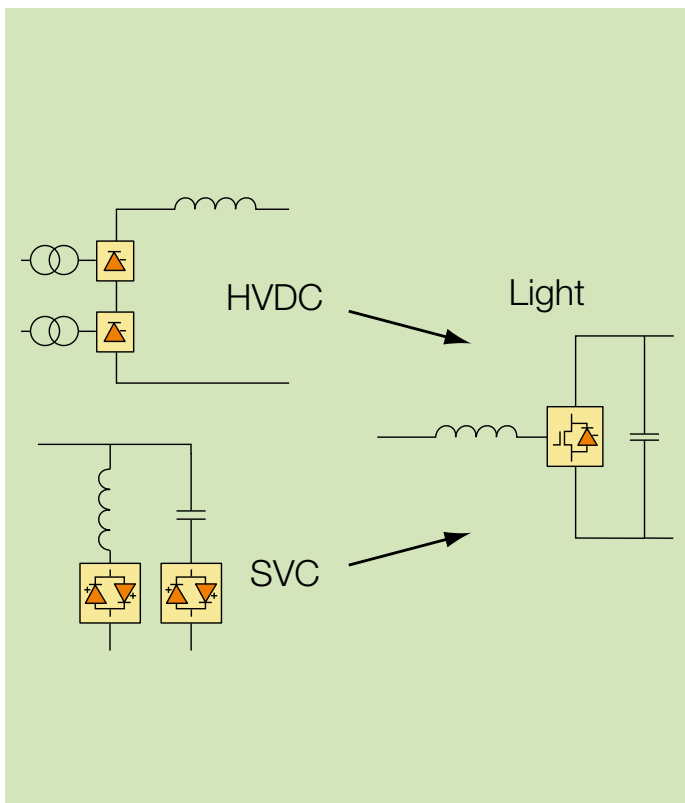

STATCOM 4-quadrant operational area.

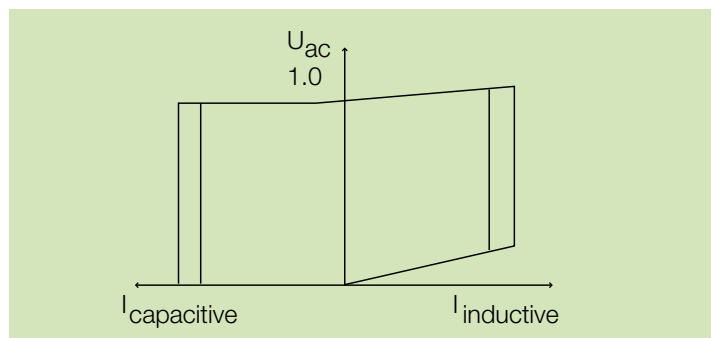

STATCOM voltage/current characteristic.

* When the converters form an HVDC scheme or interface some energy source to the grid.

SVC Light: a brief tutorial

SVC Light is a generator without a prime mover or inertia, built only with static equipment. It produces its terminal voltage without a physical rotor. The VSC principles have long been used in industrial drives, where induction motors are fed from frequency controlled VSCs. In SVC Light we do not control the frequency, but the voltage amplitude. (If active power control is “available”, then the phase angle and the frequency are also likely to be controlled.) In order to match the very high power ratings required from the VSC modules, series-connection of IGBTs is employed. The VSC modules are water cooled for full utilization of the semiconductors.

The VSC interfaces a DC capacitor with the grid, over a defined inductance. The power semiconductors within the VSC connect the two DC terminals alternatingly to their AC terminals, following a specific modulation scheme. The result is a “raw” stepped source voltage but with a dominant fundamental frequency content. Basic power system theory tells us that as long as this voltage is in phase with the grid voltage, only reactive power will be exchanged over the interfacing inductance and the DC capacitor will maintain a constant voltage. We have built an inverter-type of “generator” for reactive power.

The interfacing inductance, together with shunt capacitors of wide band harmonic filter type, trap the harmonics in the “raw” voltage such that an almost sinusoidal voltage is appearing at the point of connection. A conventional power transformer is used to adapt the medium voltage converter circuit to the actual grid voltage.

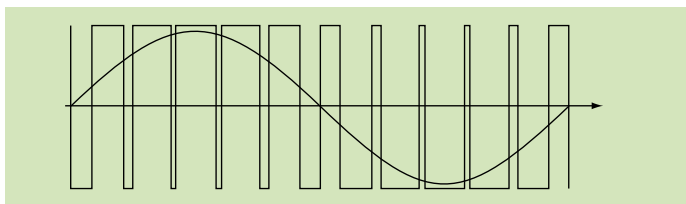

The raw source voltage.

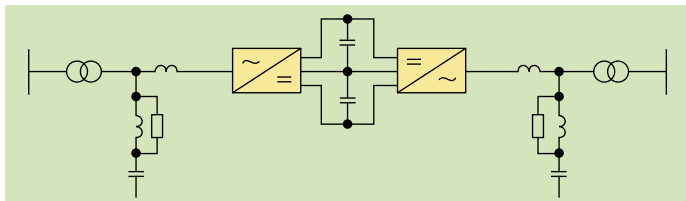

Dual Purpose scheme.

Thanks to the very high bandwidth of the SVC Light VSC module, the output voltage can also be controlled to unbalanced states, as well as to contain lower order harmonics. These unique characteristics enable the power quality performance of SVC Light, as grid unbalances and harmonics can be mitigated without the need for discrete reactive elements (inductors and capacitors).

The SVC Light not only comes with high performance. Thanks to the simplicity in the topology, requiring a minimum of components, the footprint of the SVC Light installation will be small. Further it enables a high degree of prefabrication and in-factory testing, leading to an overall reduction of project lead times and enhanced product quality.

Again, combining two VSC modules, sharing the same DC circuit, we can form an HVDC link. In a unique way this configuration provides the capability to control three parameters: voltage frequency, voltage phase angle and voltage amplitude. This HVDC Back-to-Back Light can control active power transfer and reactive power output(s) simultaneously, and will appear almost as a true generator as seen from (one of) the grid(s). In fact a “generator” with unique voltage support capabilities.

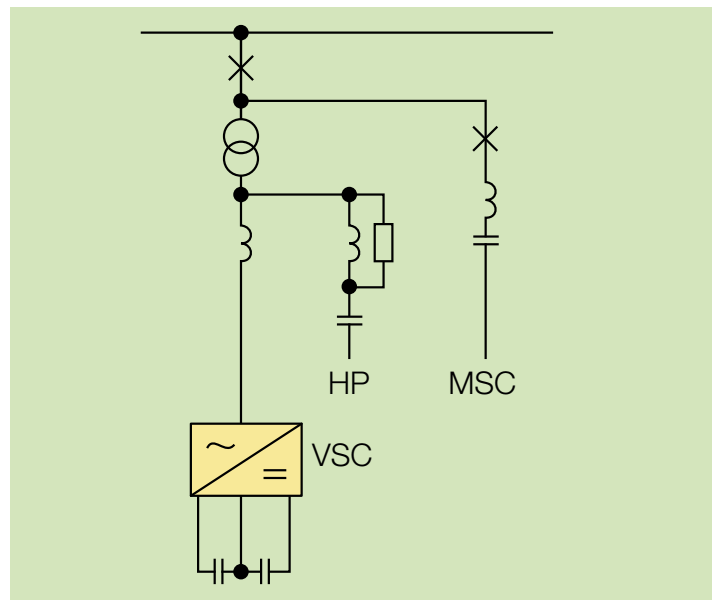

Single Converter scheme.

HP = High Pass Filter

MSC = Mechanically Switched Capacitor

Prefabricated modules





Reliability: yes, please!

With induction motors making up an ever increasing portion of power system loads, the focus on reactive power support becomes more obvious. Induction motors instantly become large var consumers upon disturbances, pushing the grid voltage to very low levels and making fault recovery difficult. SVC Light will instantly inject vars following detection of grid faults and facilitate fault ride-through and voltage recovery. In grids prone to voltage instability (voltage support from remote generators being weak) sudden voltage collapses can be avoided. Under less critical power system conditions SVC Light is an excellent means to control the grid voltage. Its capability to instantly absorb vars also makes it an excellent tool for preventing temporary overvoltages.

In downtown Austin, Texas, an old thermal power station is retired, partly because of operating costs but also for environmental reasons. In recent years, its main use was often that of dynamic Mvar provider: it could be called an RMR (reliability must run) unit. The utility needed a fast track replacement “generator”, or more correctly a new source of dynamic reactive power and chose an SVC Light rated at 138 kV/80 Mvar inductive to 110 Mvar capacitive. SVC Light was chosen because of its minimal footprint, its minimal environmental impact and its capability to support the grid even more effectively than the old generators. Grid reliability could be maintained and the downtown neighbors benefited as Mvar were now provided dynamically, quietly, almost invisibly and with zero emissions.

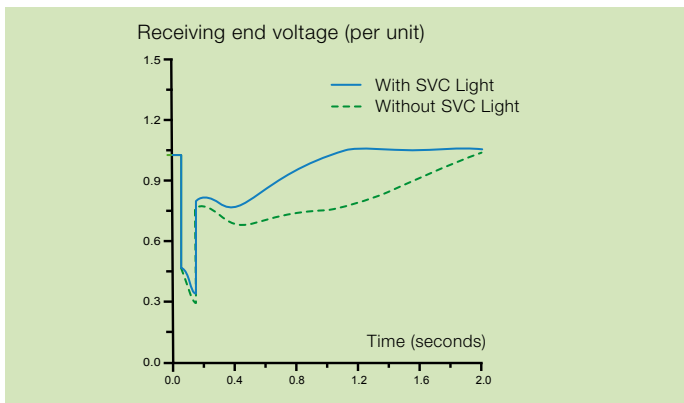

Post Fault voltage recovery with and without SVC Light.



Power Quality in a true sense

Thanks to its high speed performance SVC Light is the unrivalled power quality warrant in the very high power range of applications, such as railway systems and steel industries. These constitute huge loads on public grids, loads that are fluctuating rapidly, violently, and unsymmetrically. The grid voltage at the points of common coupling is more or less stochastically modulated by the fluctuating reactive power drawn and other nearby consumers will suffer from often unacceptable power quality. Electrical machines will run into overheating, lights will flicker and electronic systems will fail. The problems sometimes “travel” far.

SVC Light is an excellent tool to use when symmetry and balance in the grid are to be restored. It is well known that unbalanced loads can be compensated by reactive currents only, and SVC Light can elegantly be controlled on a single-phase basis and provide such reactive currents. But the converters on trains and electric arc furnaces in steelworks also produce harmonics and sub-harmonics. Here SVC Light is faced with extreme requirements on fast response. It can respond, however, thanks to its PWM controlled power semiconductors, reaching switching frequencies up to 2 kHz. The result is that the stochastic voltage flicker from electric arc furnaces, as well as all lower order harmonics, can be cancelled out by the SVC Light.

The TGV high speed trains in France and one of the world’s largest producers of stainless steel are two outstanding examples where SVC Light is used to ensure adequate power quality. In France the focus is on voltage balancing, as the train feeder is arranged from two phases of the main grid. Along with the voltage balancing, the 90 kV/±16 Mvar SVC Light installation performs active filtering of the lower order harmonics produced by the traction drives.

In Finland a huge electric arc furnace, rated at 160 MVA, is compensated by a 0/+164 Mvar SVC Light. The furnace rating is matched by offsetting the VSC output of ± 82 Mvar, with 82 Mvar of harmonic filters. The reactive power drawn by the furnace is here on a point-of-wave basis compensated with a mirror-image current produced by the VSC.

At the point of common coupling the stochastic voltage fluctuations are consequently not seen, hence neighboring consumers are not affected by voltage flicker or other distortion in their electricity supply. Also the resulting reactive power drawn from the grid becomes practically zero. For the steelworks owner this means a stable furnace supply voltage, providing higher steel production over time from the furnace. A true win-win situation for the steelworks owner and the grid operator.

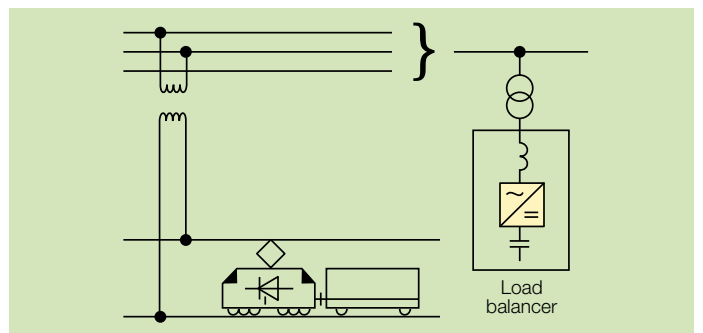

SVC Light load balancer and active filter for traction.

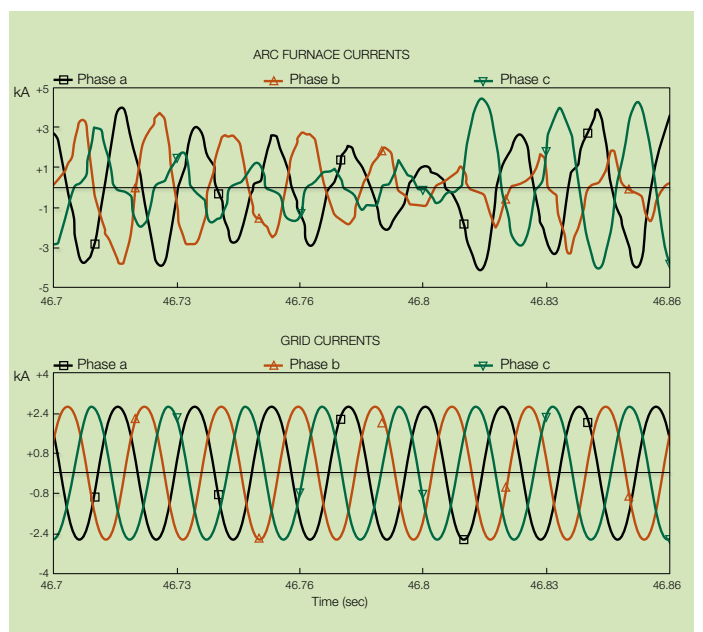

Arc furnace and grid currents, phase-wise.

Active and reactive versatility

ABB's Light platform has given HVDC a new face. The VSC modules, configured back-to-back (BtB), form an HVDC Link that not only provides fully controllable (obviously bidirectional) transfer of active power, but also supports the grids tied together, with voltage support in the form of dynamic reactive power. HVDC AND STATCOM(S) IN ONE! Additionally, the IGBT converters do not in any way depend on (the strength of) the AC grids they work against, which gives enhanced robustness. The "power receiving grid" sees the BtB Light as a (non-spinning) generator with enhanced voltage support capabilities, while the "delivering grid" sees a load with a built-in STATCOM.

In Eagle Pass, Texas, a 36 MVA BtB Light ties Mexico and Texas together. The asynchronous grids can exchange power here, where the weak Texas grid especially benefits from the STATCOM-like behavior of the installation. The ratio between MW and Mvar transfer/production/consumption is fully controllable. The black-start capability of the tie is also important, especially on the Texas side which has experienced too frequent outages as the connection with the rest of the Texas grid has been lost. The BtB Light tie enables the area around the city of Eagle Pass to be elegantly energized from the stronger Mexican grid.

The Light platform here provides multipurpose functionality in an unprecedented way, making way for asynchronous power exchange whilst enhancing the reliability.

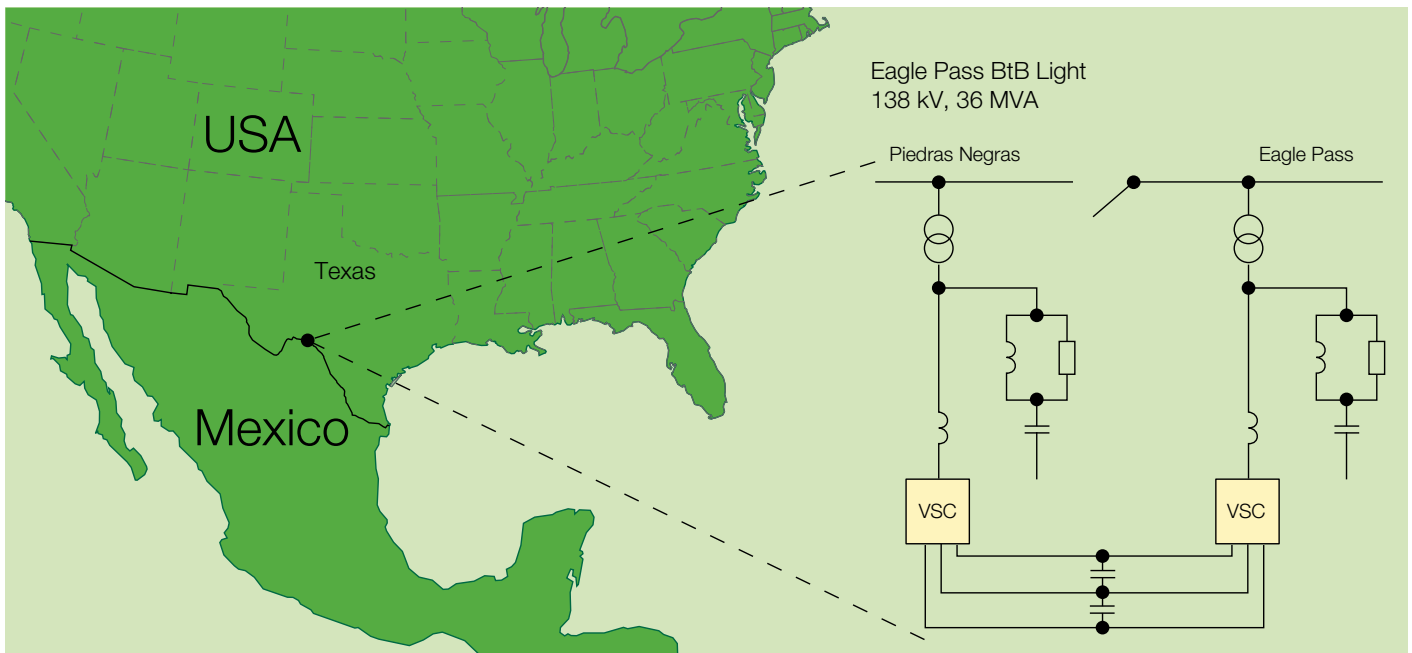

Single-line diagram, Eagle Pass BtB Light.

Dynamic Energy Storage

SVC Light with Energy Storage

SVC Light with Energy Storage is a dynamic energy storage system based on Li-ion battery storage combined with SVC Light. ABB is aiming for industry, distribution and transmission level energy storage applications. Especially the focus is on applications where the combined use of continuous reactive power control and short time active power support is needed.

SVC Light with Energy Storage enables dynamic control of active as well as reactive power in a power system, independently of each other. By control of reactive power, grid voltage and stability are controlled with high dynamic response. By control of active power, new services based on dynamic energy storage are introduced, such as load support and balancing power. Another promising area will be as part of the infrastructure for PHEV (Plug-in Hybrid Electric Vehicles).



Smart Grid

The ever increasing demand for power, and the need of reducing CO₂ emissions at the same time, require the integration of more renewable power and more distributed energy supply into the system without compromising the reliability of the supply. We need an electric system that handles those challenges in a sustainable, reliable and economic way. In other words, we need a more intelligent system that can receive power of all qualities from all sources - both centralized and distributed - and deliver reliable supplies, on demand, to consumers of all kinds. The evolved system will be based on advanced infrastructure and tuned to facilitate the integration of all involved. Since the increased use of intermittent generation requires dynamic voltage control as well as balancing power, SVC Light with Energy Storage is a great enabler of Smart Grid.



Contact us

ABB AB

FACTS

SE-721 64 Västerås,

SWEDEN

Phone: +46 (0)21 32 50 00

Fax: +46 (0)21 32 48 10

www.abb.com/FACTS