

## Electrical supply for offshore installations made possible by use of VSC technology

by

Nils Hörle  
Kjell Eriksson  
HVDC Systems  
ABB Utilities

Asmund Maeland  
Tom Nestli  
Process Industries Division  
ABB AS

### Summary

*Supplying power from land-based sources to offshore installations for the oil and gas industry has been a difficult task. In a few cases, where distances are short, it has been possible to supply power by AC transmission, but this becomes impracticable for long distances and/or for high power. Conventional HVDC would need additional equipment to achieve commutating voltages and a sufficiently high short-circuit ratio. HVDC Light™ is a new HVDC transmission system, based on VSC technology. The technology allows for relatively small filters on the installation, and the supply can feed into otherwise passive networks without the need for synchronous condensers or local generation. Being relatively compact and lightweight, and with its superior control properties, VSC technology therefore paves the way for supplying electrical power from shore to offshore installations.*

### 1. Introduction

The power demand of an offshore installation – such as an oil or gas platform – is substantial. Depending on the requirements of the process and equipment on the installation, the required power may be in the range of a few to hundreds of megawatts.

In the rare cases where installations are located close to shore, electrical power can be transmitted from shore using AC cables. However, AC power supply becomes impracticable for long distances (more than 50-100 km) and/or high power. The use of conventional, line-commutated HVDC transmission system has also been considered. However, the size and weight of the HVDC station with its filters and synchronous condenser has, together with the complexity of control (particularly

during start-up), prohibited its use on offshore installations

Therefore, until now, almost all power on offshore installations has been generated locally by gas turbines or diesels with low efficiency and high greenhouse gas emissions as a result. Platforms on the Norwegian shelf contribute 25 % of the nation's overall carbon dioxide (CO<sub>2</sub>) emissions. If the electrical energy could be taken from land, less polluting energy production could be used.

### 2. Reasons to connect offshore platforms with HVDC

Replacing local generation on offshore installations with electric power supply from shore is advantageous for two important reasons: For oil companies, it may be economically interesting – for the environment, it may lead to reduced greenhouse gas emissions.

Most offshore installations have their electric power supplied from onboard gas or diesel-driven generators. Many of these have overall efficiencies as low as 20-25 % under the best of conditions. The result is emission of large amounts of CO<sub>2</sub> and NO<sub>x</sub> (greenhouse gases) and unnecessarily high fuel consumption. A trading system for greenhouse gas emissions is already in effect within one large, international oil company, and the Kyoto Protocol supports such trading. CO<sub>2</sub> and NO<sub>x</sub> emissions can therefore represent a cost. On the Norwegian shelf, CO<sub>2</sub> taxation already in effect makes CO<sub>2</sub> emissions costly even without such trading.

If electric power can be supplied from shore, greenhouse gas emissions from offshore installations are eliminated. This leads to a significant cost saving for oil companies – an oil company has indicated to the media a yearly savings potential of 13 million USD in CO<sub>2</sub> tax if CO<sub>2</sub> emissions on the Norwegian shelf are

reduced by 80-90 %. In addition, transmission of electrical energy from shore involves less maintenance, longer lifetime and higher availability than gas or diesel-driven local power generation. If the transmission equipment can be located on decommissioned installations offshore, the postponed cost of installation removal may be an important factor.

In spite of the higher capital expenditure of electric power transmission, it can be shown that it often has a lower life cycle cost. This conclusion is of course dependent on which calculation parameters – such as fuel price, electrical energy price, efficiencies, interest rate, greenhouse gas emission trading and CO<sub>2</sub> tax – are used.

In addition, the environment can no doubt be saved from considerable amounts of greenhouse gas emissions if the electrical energy can be produced on shore with high efficiency generation instead of in low-efficiency power stations offshore. A land-based combined cycle gas power plant from which waste heat is utilized can have efficiency up to 75-80 %. Even with up to 10 % losses in a long transmission cable to an offshore installation, the savings will be significant for most installations.

- High availability 99 %
- Increased life length 30 years
- Increased efficiency
- Reduction of CO<sub>2</sub> by 65 %
- Reduction of SO<sub>x</sub> and NO<sub>x</sub>
- Less maintenance and shorter maintenance shutdowns
- Flexibility, through being able to connect several offshore installations to a single DC network

### 3. Background - HVDC Light™

Increasingly, phase-commutated or load-commutated converter technology – such as that used in classic HVDC – is being replaced by Voltage Source Converter (VSC) technology. The basic difference between the two technologies is that VSC requires components that can interrupt currents by themselves. Since the current can be interrupted, there is no need for voltage to commutate against in the connected AC network. This means that an inverter based on VSC technology is able to feed into an otherwise passive network – without the need for synchronous condensers or other forms of reactive compensation.

A further hallmark of VSC technology is that the DC voltage is, mostly, constant in all modes of operation. In a two-terminal DC transmission system, the DC voltage can be varied – albeit within relatively narrow limits – to achieve efficiency optimisation or other advantages. This is, however, not commonly done. The constant DC voltage makes it easy, from a control point of view, to make multi-terminal HVDC links. Contrary to classic HVDC, there is no DC voltage reversal connected with power reversal. In fact, the DC system

can be viewed as a bus, and any terminal connected to the bus can feed power into the bus or extract power from it without affecting stations not involved in the changed power flow direction, other than possibly minor changes of the DC voltage level.

In 1997, ABB announced its technology for HVDC transmission based on VSC technology: HVDC Light™.

In HVDC Light™, Pulse Width Modulation (PWM) is used for generation of the fundamental voltage. Using PWM, the magnitude and phase of the voltage can be controlled freely and almost instantaneously within certain limits. This allows independent and very fast control of active and reactive power flows. PWM VSC is therefore a close to ideal component in the transmission network. From a system point of view, it acts as a zero-inertia motor or generator that can control active and reactive power almost instantaneously. Furthermore, it does not contribute to the short-circuit power, as the AC current can be controlled.

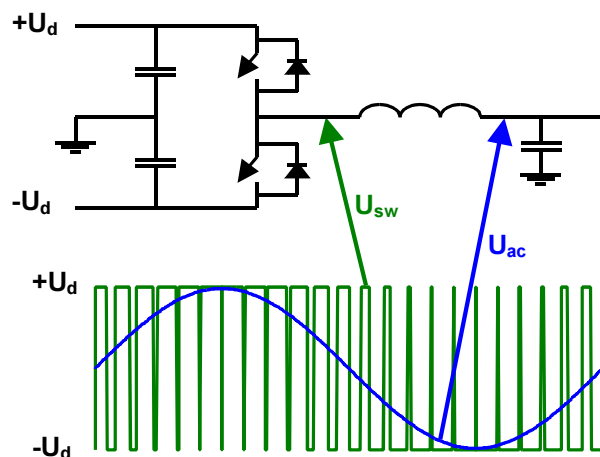
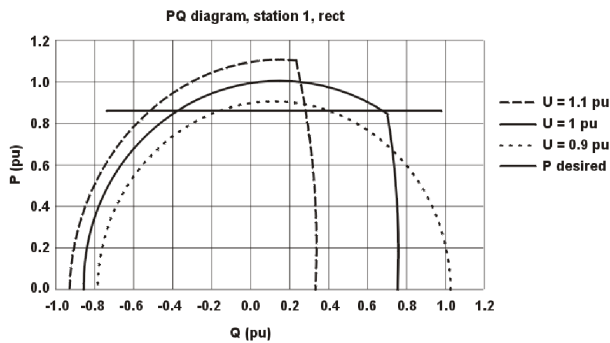

Figure 1: Principle of pulse width modulation

As a consequence, no reactive power compensation equipment is needed at the station, and only an AC filter is installed. The HVDC Light™ reactive power controller can automatically control the voltage in the AC network, without influencing the control of active power. In power supply applications, the active power is often controlled to match a setpoint. Reactive power generation and consumption of an HVDC Light™ converter can be used for compensating the needs of the connected network within the rating of a converter. As the rating of the converters is based on maximum currents and voltages, the reactive power capabilities of a converter can be traded against the active power capability. The combined active/reactive power capabilities can most easily be seen in a P-Q diagram (positive Q is fed to the AC network).



**Figure 2:** Capability chart, PQ Diagram

The voltage control of a station constitutes an outer feedback loop and generates a reactive current demand signal in such a way as to maintain the set voltage on the network bus. Because of the short response time of the system for AC voltage control, the AC bus voltage can be kept constant during transients and other disturbances. Flicker is also mitigated to a high degree. It is thus possible to use the controllability of HVDC Light to stabilize the voltage in fault situations.

An interesting feature of VSC is its ability to supply a passive network having no generation components. When supplying a passive network, the static converter controls the amplitude and frequency of the AC voltage. This function is utilized in the Tjaereborg (Denmark) and Eagle Pass (U.S.A) HVDC Light™ transmissions. Such a function can be of importance even if the HVDC Light™ system is connected to an active AC network, as it may become 'islanded' and passive as a result of system faults. An island situation in an AC-system can occur if a nearby AC breaker opens up due to a fault. The HVDC Light™ system can be programmed to switch from active power order to frequency control from a last breaker opening indication or by under-frequency or over-frequency indication.

This makes HVDC Light™ very useful for transmission of electrical power to offshore platforms. HVDC Light™ can be used for multiterminal operation, thus connecting together various platforms with one transmission link.

The HVDC Light™ concept includes another development: the HVDC Light Cable, which is an extruded polymer cable. For high-voltage AC, there has been a technology shift from paper-insulated to extruded polymer cables. The corresponding development to produce an extruded HVDC cable has now resulted in a flexible and cost-effective cable that is an important part of the HVDC Light™ concept. The new single core cables are installed close together in bipolar pairs with antiparallel currents, thus eliminating the magnetic fields.

HVDC Light™ is particularly suited for transmission of electric power to offshore installations that are located at some distance (50 to 100 km) from shore. Supplying large amounts of electric power over long cables leads,

among other things, to large voltage variations at the receiving end of the cable as the load varies. AC cables are therefore not well suited for transmission of electrical energy over distances greater than 50 to 100 km. With HVDC Light™, on the other hand, the voltage variation in the cable is smaller, and the inverter at the receiving end is able to compensate for this effect so that the AC voltage at the receiving end remains constant. There are, in practice, no technical limitations to transmission lengths for HVDC cables.

#### 4. Demands on HVDC offshore

Space and weight are scarce resources on offshore installations. Particularly in the light of these constraints, the HVDC Light™ concept offers important advantages: Since the filters are small and synchronous condensers are not required, HVDC Light™ can be made compact and lightweight compared to classic HVDC.

The compactness of HVDC Light™ is illustrated in Figures 3 and 4.

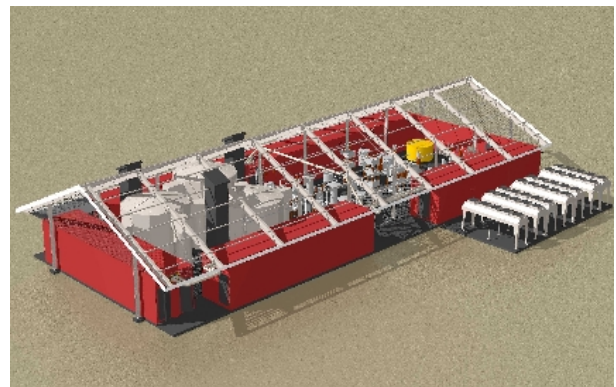

**Figure 3:** A 65 MVA land-based HVDC Light™ station requires only 18 x 45 m, excluding the transformer

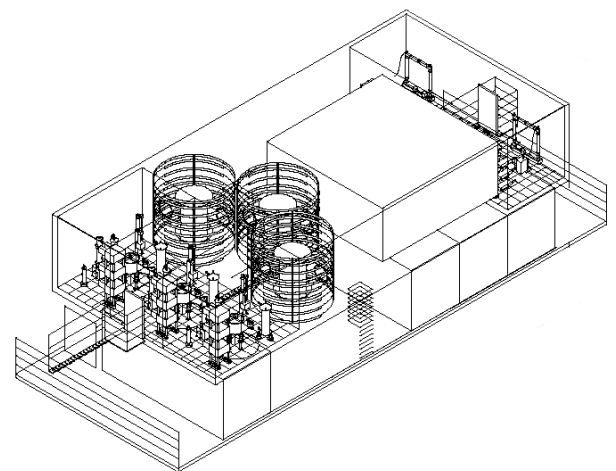

**Figure 4:** Sketch of a 250-300 MW HVDC Light™ offshore module requiring approximately (W x L x H) 30 x 40 x 20 m, including the transformer

Apart from the obvious needs to make the converter station compact and lightweight, the offshore environment places a number of other demands on the converter station and equipment. Examples include:

- Safety for personnel as well as for equipment. The most important issue is the requirement that possible gas (hydrocarbons) from production and processing does not come into contact with live parts.
- The offshore environment is very tough. Salt and humid air imposes severe requirements on the choice of materials and surface treatment. The ventilation system must protect the high-voltage equipment and the electronics from salt and humid air.

### 5. Various system configurations

The versatile HVDC Light™ concept permits many different arrangements when looking at system configurations.

The basic configuration would of course be a direct point-to-point transmission from shore to a platform supplying general power to that platform.

As many times the basic loads on the platforms are motor drives, a direct connection from shore to a motor drive could be an interesting alternative.

To spread out to several platforms a multiterminal configuration of converters could be advantageous possibility.

#### 5.1 Point-to-point transmission

This configuration consists of an HVDC Light™ transmission with converters operating at the optimum voltage for the required power. Transformers are used in the shore-based installation, and will be needed on the platform if the supply is connected to the auxiliary network (the AC network on the platform). Single-phase transformers can be used in order to reduce the weight of individual items. The fast control of active and reactive power makes the VSC transmission an optimum instrument to control frequency and voltage in the platform AC system and to suppress disturbances on the AC bus.

The various loads on platform system will then be supplied from the VSC inverter station with a common frequency and voltage. Distribution to lower service levels voltage will need further transformation in a usual way.

Distribution to neighbouring platforms can be made with conventional ac transmissions.

#### 5.2 Electric drive system

Some offshore installations require high-power, adjustable-speed compressors. HVDC Light™ together with a Motorformer™ motor can be combined into an electric drive system that can be used to drive such

compressors, for example. Motorformer™ is another innovative technology, introduced by ABB in 1998. Motorformer™ is a motor in which the stator winding is in the form of extruded cable instead of copper bars. This enables motors to be designed for operation at much higher operating AC voltages (up to 150 kV), compared with standard motors. A transformer between the inverter and motor can therefore be omitted, thereby reducing the offshore weight significantly. In this type of transmission, the requirements in respect of receiving end harmonic filtering are lower than for normal transmission. This makes it possible to reduce the filter size and the size of the offshore converter reactor, and so reduce the weight of the installation.

With only a dedicated load on the VSC, it can be used for frequency and voltage control according to the needs of the motor drive.

### 5.3 Multiterminal – power supply to many platforms

One feature of the HVDC Light™ converter is that the polarity does not change when the power flow changes. Instead, the current direction changes. This makes it easy to use a converter as a building block in a multiterminal system.

Any number of HVDC Light™ converters can be connected to a DC bus with fixed polarity, which means that it is possible to build a meshed DC system, with the same topology as an AC system. This can be useful when supplying a number of platforms.

### 6. Electrical supply vs. local generation; economy

A number of parameters influence the result when comparing the economy of supplying electrical power from shore to offshore installations with that of local power generation., see Table 1. Oil and gas prices assume that consumption of fuel for local generation reduces the amount of fuel sold. However, on some installations, gas may be available as an (unwanted) by-product from oil production with no gas export possibilities – in such cases, fuel consumption may be a low cost issue. Or, the opposite situation, diesel fuel or gas needs to be transported to the installation and thus increases the operating cost of local generation.

**Table 1: Parameters influencing project economy**

Parameter	Typical values
CO <sub>2</sub> tax (on the Norwegian shelf)	300-350 NOK/tonne
Oil price	20-30 USD pr barrel
Gas price	0.7-1.5 NOK/Sm <sup>3</sup>
Gas turbine efficiency	20-36 %
Electricity price	0.17-0.23 NOK/kWh
Exchange rate USD/NOK	8.75

The project net present values (NPV) can be calculated for economic comparison of electrical supply and local generation. Table 2 lists the characteristics that have the greatest influence on NPV for an electric power supply

when compared to local generation. The outcome of the NPV analysis is highly project-dependent, and is strongly influenced by the parameters listed in Table 1 as well as by the chosen interest rate.

**Table 2: Characteristics with the greatest influence on electric power supply economy in relation to local generation**

Parameter	Year 0 (Installation)	Year 1...n (Operation)
Saved maintenance costs		+ <sup>1</sup>
Saved fuel cost		+
Saved CO <sub>2</sub> tax		+
Increased oil and gas production due to higher availability		+
Loss of production due to modifications	- <sup>2</sup>	
Investments in equipment	-	

<sup>1</sup> A '+' indicates a characteristic that economically favours electrical power supply

<sup>2</sup> A '-' indicates a characteristic that economically favours local generation

There are two major types of projects: new, referred to as greenfield projects, or modification projects. For greenfield projects, the NPV is an indication of how much greater the investment can be for an electrical power supply than for local generation. For modification projects, in which local generation and its infrastructure already exists, it is more difficult to justify use of power from shore, as investments in local generation have already been made. However, restrictions on greenhouse gas emission levels may force the operators to modify the power generation scheme.

Figure 5 illustrates the window of opportunity for electric power supply from shore to offshore installations. The x-axis is the distance in km from shore to platform, the y-axis is the demand for power in MW. If the power demand is small, the economy of local generation is hard to beat. If the power demand is higher, but the transmission distance is short, AC cables are typically the most economical option. The remaining window – high power demand and long transmission distance – is the economical window of opportunity for HVDC Light™.

As shown in Figure 5, the window of opportunity for HVDC Light™ will shrink if CO<sub>2</sub> taxation is low. The same effect results from the use of high interest rates or short installation lifetime – in these cases, the higher investment is difficult to recover through lower operation costs.

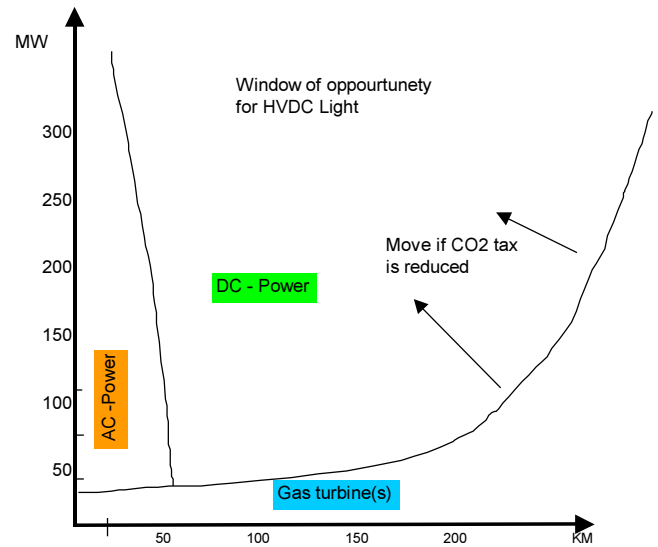

**Figure 5: HVDC Light™ window of opportunity**

## 7. Operation security (availability, operation experience, etc.)

Since its introduction, ABB has commissioned five HVDC Light™ transmissions, and another two transmissions are in the design and production phase (see Table 3).

Operational experience from Gotland (Sweden) and DirectLink (Australia) verifies independent, fast and precise control of active and reactive power in sequence with variations in the AC grids.

The encouraging experience from the commissioned links also shows that HVDC Light™ stations can be designed so that maintenance shutdowns are required only every second year – and then only for a couple of days. The lifetime of the system is more than 30 years with a predicted availability of 99 %.

The Cross Sound Cable (U.S.A) and MurrayLink (Australia) systems have brought HVDC Light™ transmissions up into the commercial power range of 200-300 MW.

Four HVDC Light projects have now been finalized and taken into operation. The experiences from commissioning, trial operation and early operation confirms all expectations regarding the behaviour of an HVDC Light link both with regard to transmission of power and the possibilities to control it. The independent control of reactive power has shown very valuable for voltage control and keeping up network operation in connection with disturbances in the network and recovery after disturbances. Features such as black start and variable frequency operation have shown to work well.

**Table 3: Reference list HVDC Light™**

Project	Country	Owner	MW MVA	Cable length	In operation
Hellsjön	Sweden	VB Elnät/ABB	3	OH line	April-1997
Gotland	Sweden	GEAB	54	2 x 70 km	Nov.-1999
DirectLink	Australia	M-LINK	180	6 x 65km	June-2000
Tjaereborg	Denmark	Eltra	8	2 x 4km	Sep.-2000
Eagle Pass	USA	CPL	36	BtB	Nov.-2000
Cross sound Cable	USA	TransÉnergie	330	2 x 40 km	July-2002
Murraylink	Australia	TransÉnergie	200	2 x 180 km	Oct.-2002

## 8. Conclusions

In most cases, power supply to offshore installations from shore has been difficult or even impossible as long as the alternatives have been AC cables or classic line-commutated HVDC systems. VSC technology has enabled development of HVDC systems with converter stations that require smaller filters and no local generation or synchronous condensers, and with control properties far superior to those of classic HVDC. The technology, termed HVDC Light™, now makes it possible to supply electric power from shore to offshore installations.

Through a number of HVDC Light™ installations, the advantages, reliability and flexibility of the technology has been verified. Encouraging experience includes superior control properties and very high availability. The commercial step to 200-300 MW HVDC Light™ transmissions has been taken, with projects now in the design and production phases.

There are two main reasons for supplying power from shore to the installations: for the operator of the offshore installation, it may mean lower costs and/or higher revenues, while for the environment it means significant reductions of greenhouse gas emissions.

The flexibility of the VSC technology has many benefits: point-to-point transmission, multi-terminal transmissions and – in conjunction with innovative motor technologies such as Motorformer™ - electric drive systems.

Placing high voltage equipment on offshore installations poses many challenges, of which some are size and weight constraints, safety considerations and the harsh offshore environment.

The VSC technology eliminates the constraints that have earlier made transmission of electric power to offshore installations difficult – so that it is now not only profitable but also environmentally sound.

## 9. References

- [1] Asplund, Eriksson, Jiang, Lindberg, Pålsson, Svensson: DC transmission based on voltage source converters, Cigré SC14 Session, Paris,
- [2] 1998. Axelsson U, Holm A, Liljegren C, Åberg M, Eriksson K, Tollerz O.; The Gotland HVDC Light project – experiences from trial and commercial operation; CIRED 2001, Amsterdam, Netherlands, June 2001.
- [3] Soebrink K, Soerensen A, Jensen J, Holmberg P, Eriksson K, Skytt A-K.; Large-scale offshore wind power integration and HVDC using Voltage Sourced Converter; Cigre fourth Southern Africa regional conference, Cape Town, South Africa, October 2001.
- [4] Eriksson K, Operational experience of HVDC Light; IEE 7<sup>th</sup> ac/dc power transmission conference, London, November 2001.
- [5] J. Wasborg - Operational experience of Directlink (Distribution 2001 in Brisbane/Australia, November 12 2001)