

STEEL PLANT PERFORMANCE, POWER SUPPLY SYSTEM DESIGN AND POWER QUALITY ASPECTS

Power Quality leads to improved production and costs savings

Antonio Silva

ABB Power T&D Company Inc.
Raleigh NC

Lars Hultqvist and Aleksander Wilk-Wilczynski

ABB Power Systems AB
Västerås Sweden

ABSTRACT

For a steel producer optimum performance, namely cost-efficient production, is of primary interest. Therefore, from his point of view, any investment in the electric power supply is always seen as a cost. This applies in particular to Power Quality equipment such as SVC, which is justified only if it enables increased production or energy savings.

Different aspects of this issue are highlighted in the paper.

1. INTRODUCTION

Views have been expressed on different occasions that all efforts to increase power quality in the steel plant supply systems only result in additional investment costs for the steel producer, while retaining all advantages on the power utility side.

In the opinion of some people an SVC is a necessary evil that should be avoided whenever possible. Some "strategies" on how to "negotiate away" the SVC equipment have even been presented in papers.

Through a few simple examples we shall try to prove the opposite, namely that the improvement of

power quality in the supply system, and in particular the installation of a properly designed SVC, is an advantageous investment for steel manufacturers and may bring substantial gains from the production point of view.

We also wish to stress how important it is when designing steel plant power supply that the installation of an SVC should not be considered at the final stage when all other equipment has already been sized and ordered but instead should be a part of an optimization plan for a complete power supply system for a steel plant. This is valid both for brand-new green-field plants and for revamping and extensions of existing plants.

2. THE STEEL PLANT AS AN ELECTRIC LOAD

For a power distributor, a modern steel plant represents a somewhat dubious customer. On the one hand, the plant may be the biggest paying consumer in the distribution system; on the other hand, the same consumer through the nature of his load disturbs power quality for the other consumers connected to the network.

The short time varying load, as occurs in rolling mills, and largely represented by electric arc furnaces (EAFs) with their almost instantaneous fluctuations in both active and reactive power, are the main sources of disturbance.

The interconnection point in the grid between the power utility and the steel plant, generally designated PCC (Point of Common Coupling), then becomes a terminal of high importance. This is particularly true now that several countries have begun to deregulate their power transmission systems. Concepts such as "power quality" have been introduced in order to set rules and regulations for networks with an increasing amount of voltage pollution.

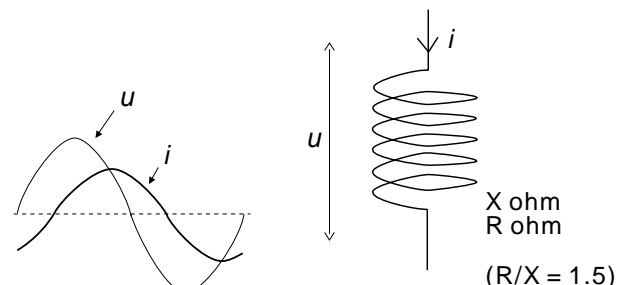

Fig. 1. "Load" at a poor power factor of $\cos \phi \approx 0.6$.

For an inductive feeding network, which is the most common, it is mathematically simple to show that, setting the plant reactive power at a low value with small fluctuation in time, the network voltage quality will increase considerably even if the fluctuation in active power still exist. Fig. 1 shows an example of an inductive load at a poor power factor.

Fig. 2 illustrates typical features of poor voltage quality.

The specific short time undervoltage and overvoltage variations often described in literature as voltage sags and voltage swells may have hazardous impacts on sensitive equipment connected to the network, such as computers and X-ray units.

In addition, the varying loads also create network disturbances in the form of phase unbalance and voltage flicker; nowadays a very frequently discussed subject.

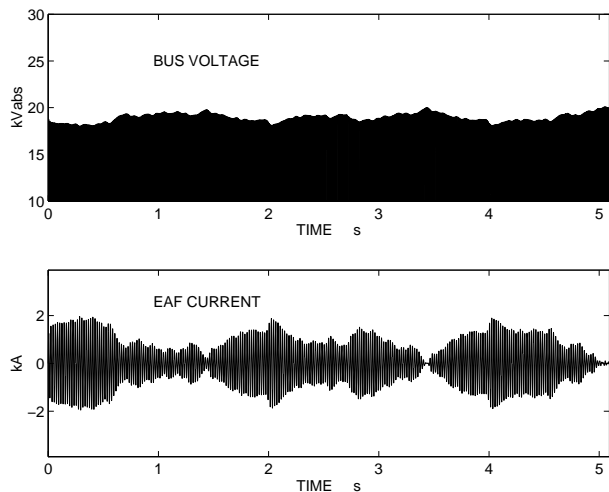

Fig. 3.

The heavy voltage fluctuation caused by the furnace low frequency load current content varies with the current as a typical amplitude-modulated curve shape as seen in Fig. 3.

The state-of-the-art device able to control and keep the plant reactive power consumption within

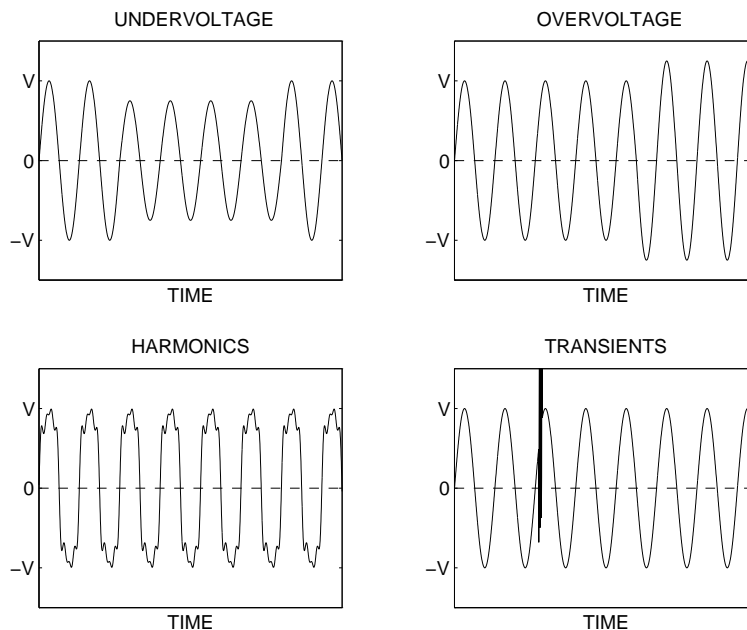

Fig. 2.

acceptable limits is the **Static Var Compensator (SVC)**. The typical SVC comprises a set of **Fixed** power factor correction **Capacitors (FCs)**, divided and tuned to form the harmonic filters. A **Thyristor Controlled Reactor (TCR)** with a fast acting regulator ensures the SVC's capability to change its reactive power output, following the plant reactive load closely.

3. DESIGN OF POWER SUPPLY SYSTEM

The three basic cases can be identified here with different preconditions.

- **A.** Revamping and installation of more powerful furnaces in an old plant
- **B.** Extending of an existing mill with electric furnaces
- **C.** A brand-new green-field project

The examples relevant to these three cases are described below.

The examples comprise application of both AC and DC types of EAFs. A point of interest is the variation in the power quality stipulations caused by diverse national or even local regional standards.

Example A

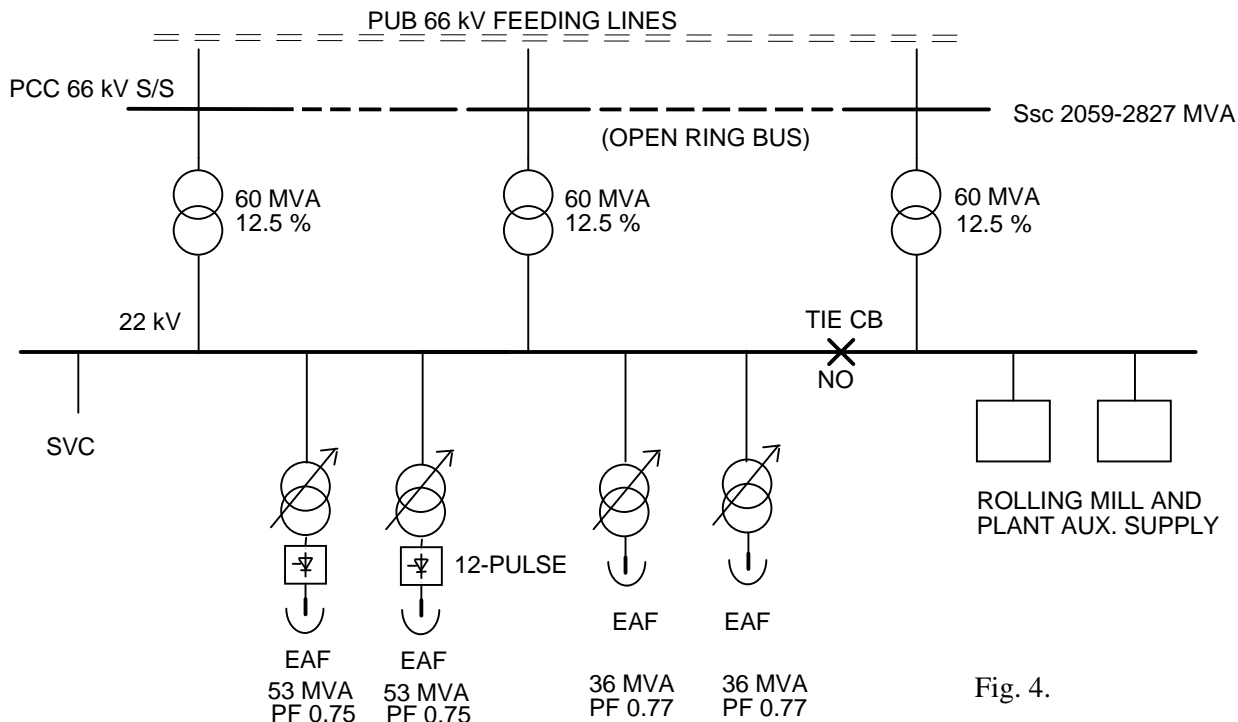

Fig. 4.

Our first example illustrates the very common case of upgrading of existing plants. This actual plant is located in Singapore and the intention was to install, to start with, only one new DC EAF, but after some months another identical furnace was installed. Old sites for AC furnaces had to be used. Two of the existing AC EAFs would remain in operation. The four furnaces could be operated in all possible combinations, but with only two simultaneously running at full load.

The stringent power quality regulations set by the Singapore utility (PUB) limited the use of new furnaces and made necessary the installation of compensation equipment. In other words, the impact of new, more powerful furnaces on the feeding network had to be limited. The necessity of use of existing MV switchgear, however, limited the possibility of installing a sufficient amount of reactive power as the current handling capacity of existing circuit breakers on the feeders had to be considered. The new SVC replaced the existing small size compensator and had to fit into its location. The thyristor valve, control equipment and new subdistribution switchgear were housed in a new compact building. A simplified single line diagram of the plant is shown in Fig. 4 above.

The main factors to be considered were as follows:

- Power factor limitation (no over-compensation accepted)
- THD in voltage (THD = Total Harmonic Distortion)
- Voltage unbalance
- Voltage fluctuation (flicker defined according to ERA)

ABB's technical studies indicated that the demands could be met by an SVC rated -2/56 Mvar and with the capacitive power divided in a set of filters as per Fig. 5. Field measurements performed confirmed that the plant meets the stipulated demands with the installed SVC.

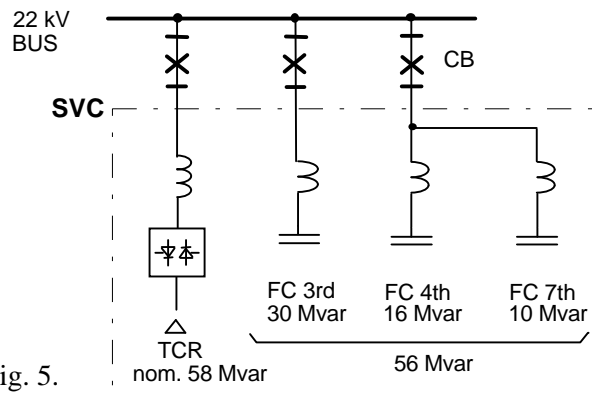

Fig. 5.

Example B

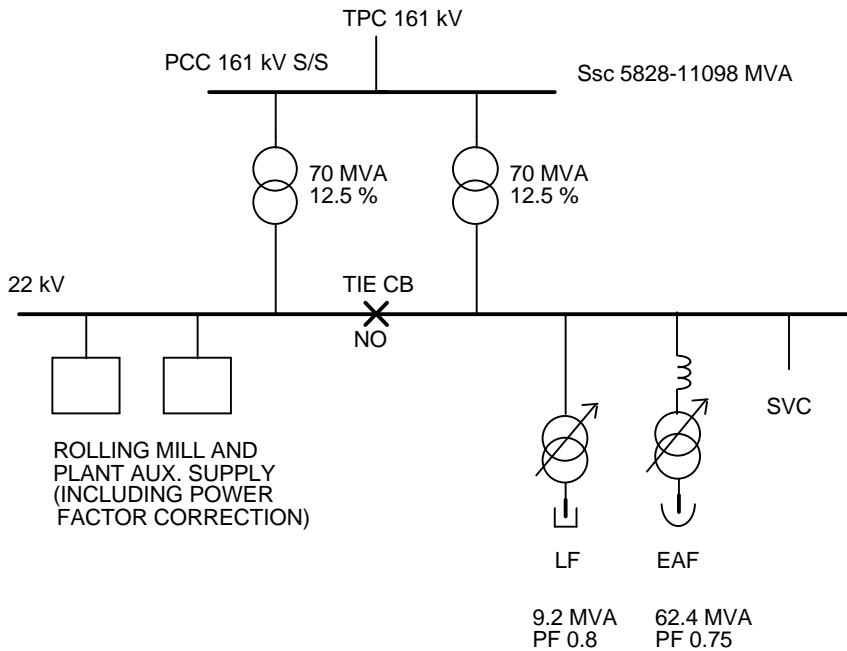

Fig. 6.

Our second example represents a steel plant with existing two rolling mills, to be expanded on the metallurgical side with two new electrical furnaces: an AC EAF and a LF. The plant is located in a heavy industrial district in southern Taiwan and the system expanded in this manner had to meet the severe regulations imposed by the Taiwan Power Company (TPC).

The simplified plant single line diagram is shown in Fig. 6 above.

The main TPC demands here covered:

- Power factor (no over-compensation accepted)
- THD in voltage
- Harmonic current distortion
- Voltage fluctuation (flicker measured according to V10)

The critical design criteria in this plant were primarily the limitation in the voltage fluctuation, but also the fulfilment of the rather rigid limitation in the harmonic current content which necessitated extended computer studies to define the best possible filter combination. The EAF is required to remain in operation under emergency conditions with one

transformer only and a closed tie-breaker, without any risk of resonances between the SVC and the mill's power factor correction capacitors.

In this plant the SVC thyristor valve and the control equipment are located in a small container-like building within the compensator's 22 kV switchyard. An SVC rated -5/70 Mvar with filter power divided as in Fig. 7 was finally implemented.

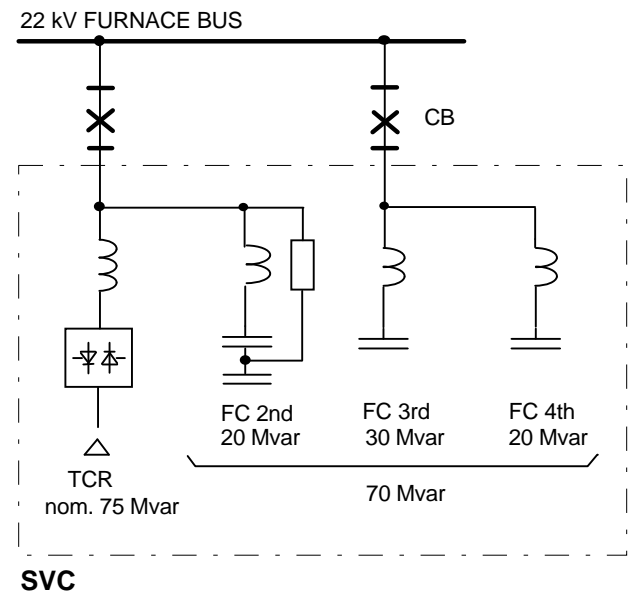

Fig. 7.

Example C

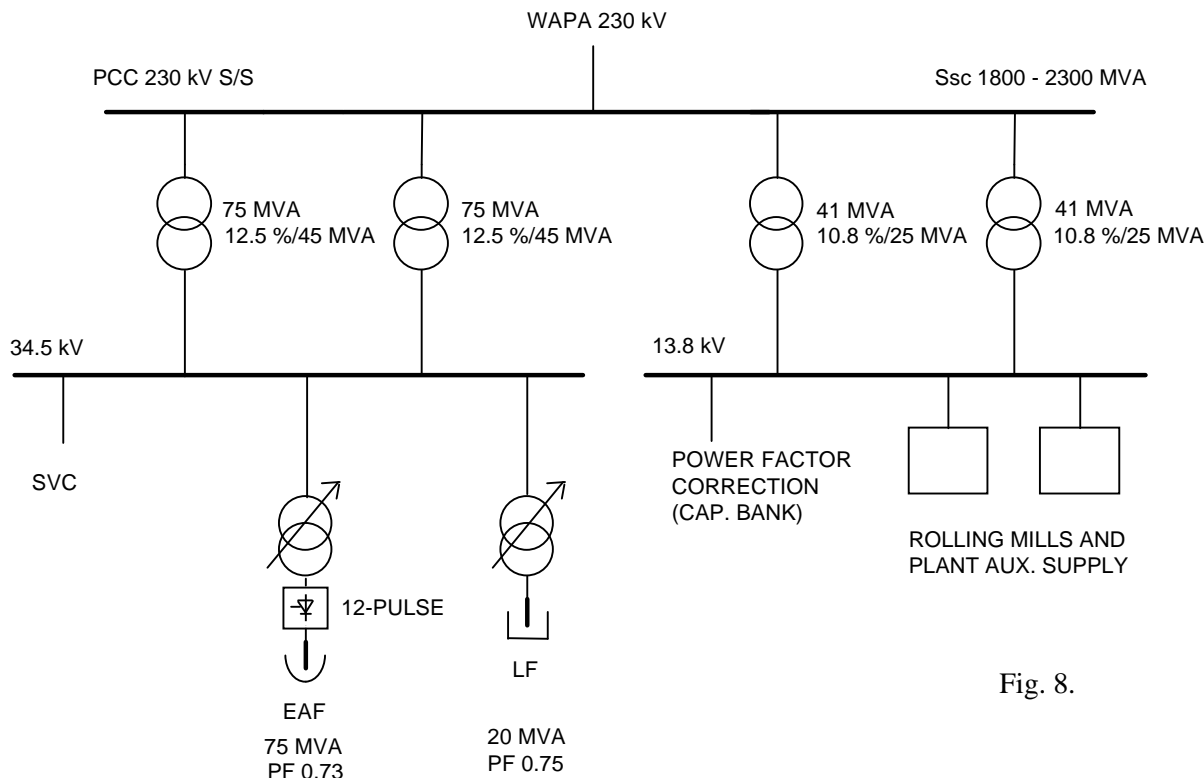

Fig. 8.

Our third steel plant is a typical example of a green- field project. This plant is located in the mid-west of the USA and the installation will represent a drastic change in the power transmission network in a wide area surrounding the mill. Even if the strongest possible connection to the interstate 230 kV system is made, the fault level will still be very low.

To control and keep the “network pollution” down to acceptable limits the utility imposes quite strict demands on plant operators, such as a flicker level below IEEE 519 “border line of irritation”, also to be applied at the lowest system fault level in use.

The main demands here again covered:

- Power factor limitation
(no over-compensation accepted)
- THD in voltage
- Harmonic current distortion
- Voltage fluctuation
(flicker according to flat top measurements)

To fulfil the demand of having a plant power factor close to unity it is also necessary to compensate the reactive power consumption in the

rolling mills and the auxiliary systems. Therefore, a fixed capacitor bank was added to the rolling mill’s bus. Step down transformers with high impedance were used as well as smoothing reactors on the DC furnace high current side as additional means together with the SVC. The purpose was to prevent, as far as possible, the disturbance from being fed into the utility transmission system. With limitations in both the voltage and current distortion, the proper design and selection of the tuned capacitor banks are of utmost importance and here again detailed computer calculations had to be performed.

The SVC was finally rated 95 Mvar, with the filter banks divided as in Fig. 9.

In this plant the SVC outdoor switchyard is integrated with the furnace substation and the indoor valve and control equipment housed in the main substation building.

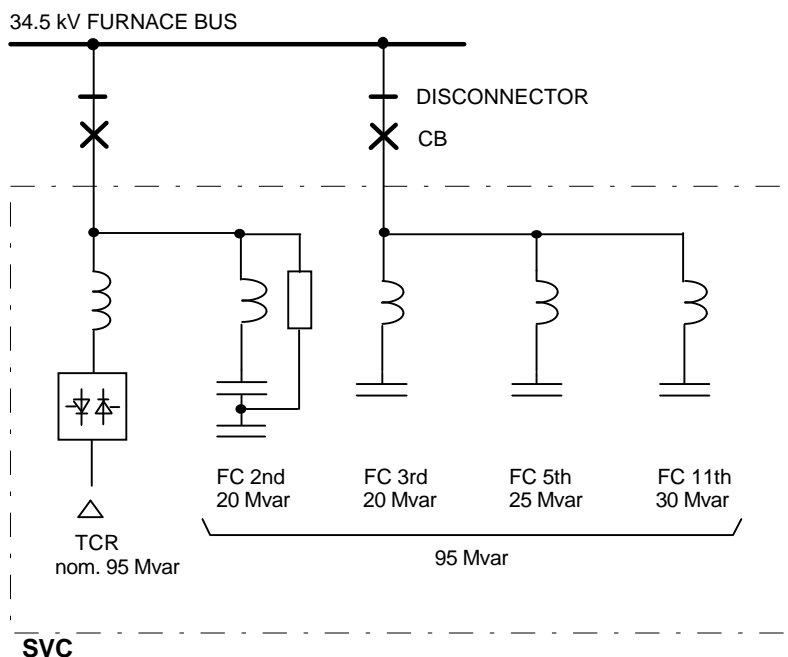

Fig. 9.

The figure illustrates a typical SVC of today, built up with a TCR as the inductive element and a set of capacitors forming different filters (three BP types and one C type).

Looking back to our three examples one can observe details common to these plants and also to the majority of the steel plants around the world. The power from the utility is supplied by a transmission network at the highest possible regional fault and voltage level. The furnaces, in turn, are located at a medium voltage level insulated from the transmission grid by one or more step down transformers. The medium voltage is selected to suit the size of the furnace and the market availability of equipment such as the furnace breakers and tap changers. Usually some form of back-up power supply is arranged. To rely on only one step down transformer may be risky; a simple fault can result in a long plant standstill. In plants with the same internal distribution voltage level in the furnaces and mill sections, it can be a suitable precaution to insert an emergency tie switch between the buses. In an emergency parallel operation fed by the mill supply, the mill suffers from the voltage fluctuations but steel production will still be possible. This type of rarely needed emergency operation is often more cost-saving than the insertion of an extra step down transformer, taking into consideration both installation costs and the total active power losses.

However, one can also observe some distinctive differences between the examples. The feeding network fault levels vary as well as the connected loads. To comply with the differing power quality stipulations all the SVCs must be tailor-made to fit each plant. The size of installed reactive power will vary due to the load, and the division of the capacitive banks into tuned filters will also be different. Each plant will be a unique one of a kind if the very best operation behaviour is to be achieved, and extensive computer studies are needed.

As is obvious from our first example, the SVC design must involve several different considerations, such as future extension plans or more or less temporary changes in the network parameters. It is quite often the case that the system fault level in reality is outside (and normally below) the given limits. Here we must seize the opportunity to point out to the presumptive SVC buyer the importance of not only estimating the SVC rating from the net power installed but also taking into consideration the available capacitors' gross power and the filter configuration. An SVC for industrial purposes must be built as a robust tool and with a good margin to withstand unforeseen stresses caused by ongoing changes in plant performance requirements following increased production demands, etc.

From the point of view of the electrical engineer, the ideal case is our third example as it gives the possibility of optimum design of the system, with only two limitations:

- The expected production requirements.
- The actual PCC system fault level, together with supplied voltage level and energy rates.

In the case of green-field projects even this can be optimized as the geographical site for investment may be subject to free choice. Once the production aims are established and the size in tons of the furnace defined, the electric supply system can be designed. A very important element is here the step down transformer whose rating and impedance will directly affect the production as well as the flicker disturbance level in the network. In the case of an AC furnace, a high impedance system in form of a series reactor, resulting in a long arc, is recommended. In the case of a DC type of furnace, more powerful smoothing reactors should be considered.

In the second example, the electrical engineer has less freedom of choice. But there is still the possibility of optimizing the furnace circuit with the transformer and series reactor in a total approach together with the power factor corrective equipment.

4. POWER QUALITY ASPECTS AND STEEL PLANT PERFORMANCE

Section 3 above, with the three examples of steel plants and associated comments on electrical design, may have given the impression that the main purpose of power factor correction equipment is to fulfil rigid demands forced upon the plant operator by the utility. In the following we should like to show the positive influence and beneficial production features the plant operator will obtain by increasing Power Quality.

4.1 General comments on utility demands

• **Power factor limitation**

This demand may seem to be easy to fulfil, but there are complications in compensation of fluctuating loads, which means that careful calculations have to be made.

The first important parameter is if over-compensation into the utility network is accepted or not. According to our experience of dealing with several heavy steel mills, such a situation will seldom be accepted as a normal condition.

Power factor compensation demand with mechanically (CBs, etc.) switched capacitor banks will force frequent switching operations, with both heavy wear and network disturbance as a result.

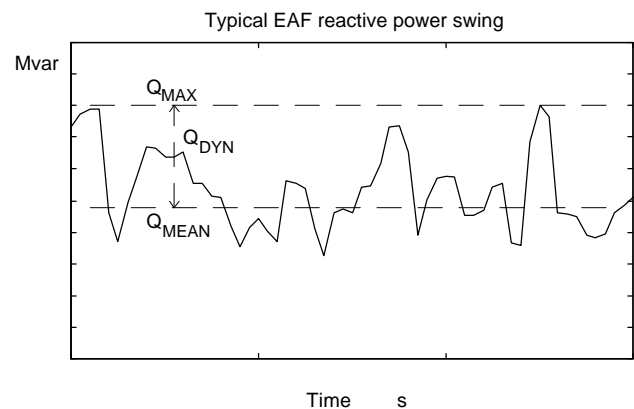

Fig. 10.

Furnace mean active power

$$P_{\text{mean}} = S_{\text{rated}} \times \cos \phi$$

Furnace mean reactive power

$$Q_{\text{mean}} = S_{\text{rated}} \times \sin \phi$$

Let us again use our second example. To compensate only this rather small EAF plant involves a **mean reactive power** consumption up to a demand of power factor 0.95, a low demand today, seen over a long time interval, say 24 hours. Simple calculation indicates that a range of 32 Mvar would be sufficient to compensate the furnaces. However, some more Mvar must be added to compensate the loss in the step down transformer up to the PCC as well, in all 36 to 38 Mvar. With shorter integrating time intervals, typically 10 to 20 minutes, in some plants down to 3 seconds, this fixed filter compensation will be too small to keep a mean power factor at the required value. In particular, one must take into account the delays caused by the switching procedure (discharge times, etc.).

It is easy to understand that an insertion of this range of uncontrolled capacitor banks at the furnace's bus would cause voltage variations far beyond acceptable standards. A voltage fluctuation in the range of 11 % would be seen at the furnace bus, starting with an overvoltage close to 8 % in no load condition and followed by a corresponding undervoltage of more than 3 % at full furnaces operation. These figures are, of course, not acceptable for the plant operator as they would result in much less efficient furnace operation.

Installation of an SVC with continuous control of the reactive power will not only solve the problem of voltage variations originating from the fixed capacitor operation but also give the possibility to compensate the dynamically fluctuating power in the furnaces.

By compensating the “static” mean reactive power and the power needed by the dynamic fluctuation, as well as the losses in the step down transformer, there is a need for an SVC rated 70 Mvar as in our example. This results in increasing the mean power factor at the PCC to a level above 0.98. In practice, the power factor will be close to unity most of the time.

⇒ The nearby rolling mill, connected in parallel, will suffer from the voltage fluctuations caused by the furnace operation but will also, if not properly compensated, have a negative influence on the network. Together with the impact of the furnaces, the total network distortions may easily exceed the stipulated demands.

⇒ It may not be possible to operate the LF in the optimum manner if the furnace bus voltage fluctuates rapidly and drastically due to EAF operation. The bus voltage must be stabilized.

- **Reactive power consumption**

The above presented principle, i.e., calculating not only the furnace mean power consumption but also taking into consideration the fluctuating dynamic part when designing compensating equipment is very important. If the compensation power is not sufficient, the bus voltage will decrease drastically each time this limitation in power output is reached. The voltage reduction will lower the melting capability and thus increase the tap to tap time.

The fluctuation in the incoming feeding voltage may lead to unstable arcing and most certainly to a high flicker level. Our examples include furnaces of both AC and DC type and without indicating preference for any of the two types, we as suppliers of power quality equipment must stress the similarity in reactive load fluctuation.

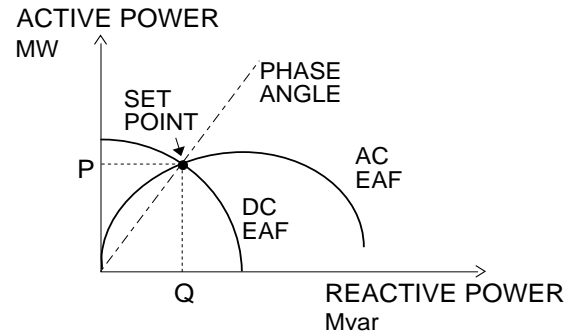

Fig. 11.

Fig. 11 above has been published in different papers as an impressive example proving that an AC type furnace might need twice the value of dynamic reactive power compared with a DC furnace operated with same active power. However, this is generally an unfair comparison. Field measurements indicate, on the contrary, that the fluctuation in reactive power (expressed as the value during 95 % of the time) is almost in the same range. This is illustrated in the simplified diagram in Fig. 12.

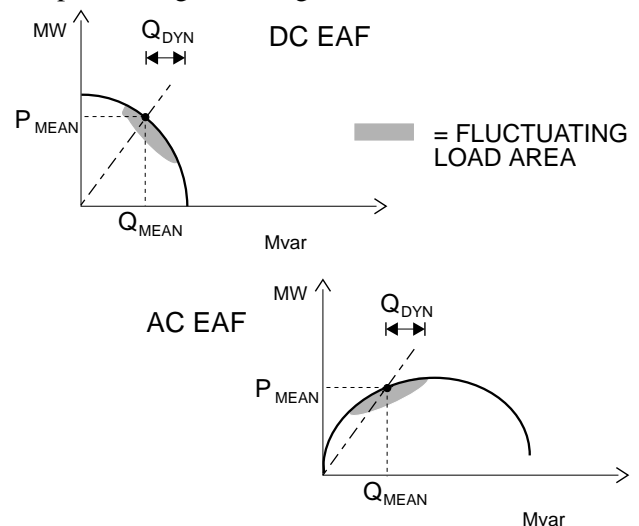

Fig. 12.

Some papers present various complicated theories as to how to keep the reactive power variation in DC furnaces down, but so far practical experiences of

these are limited. In any case an action that may cause limitation in the control of the melting operation or may generate additional network disturbance (for example phase unbalance or increased harmonic generation) should be avoided.

- **Voltage fluctuation and flicker**

A further limitation common in our three examples is a result of demands regarding voltage fluctuation. In the described cases only voltage fluctuation in the form of flicker is limited by the utility. Stipulations imposed to control the slower voltage variations at PCC are also common. The latter are unfortunately often mixed up with the more “aggressive” continuous flicker voltage modulation, as seen for instance in Fig. 3.

Without going into the rare occurrence of furnace short-circuits, often even the normal furnace operation with instant power swings from no-load to full-load condition will utilize most of the permitted voltage variation range without the stabilizing effect of SVC on the furnace bus.

In general it is better to use terms such as **voltage quality** at a bus instead of talking about some short circuit voltage depression. The bus voltage variation should not deviate by more than the stipulated level (say $\pm 2\%$) expressed in an integrated r.m.s. value during a given time interval (typically 3 seconds or 10 minutes). Note also that the greatest impact on the network from the furnace will come from the transients caused by inrush current upon switching in.

Even if the voltage flicker, by definition, will mainly disturb the human perception of light sensitive electronic equipment will also be influenced by the distortion. As an example, the steel plant’s internal computer system may temporarily be set out of order by the influence of furnace flicker. This risk is not to be disregarded.

A properly designed SVC will, to a great extent, attenuate the low frequency flicker down to a more acceptable level, as per the example in Fig. 13.

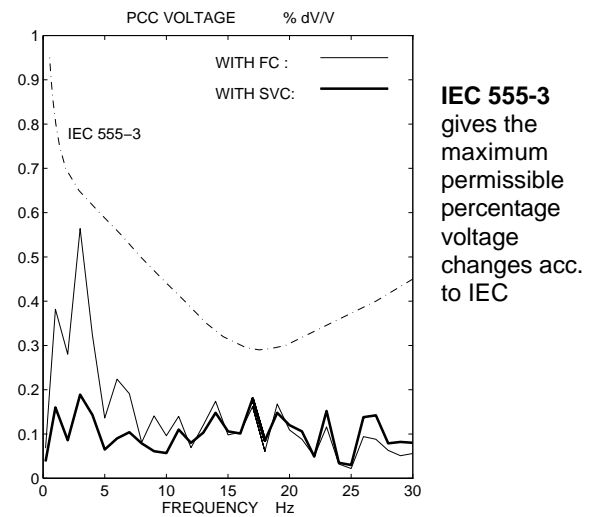

Fig. 13.

Looking at Fig. 13 one may feel that the SVC is not needed as no signals are above the borderline; however, it is important to understand that it is the total integrated amount of the modulated low frequency signals into the carrier fundamental (50 or 60 Hz) which will create the flicker perception. In practice, it is very seldom that the flicker sensation is generated by only one single frequency and to achieve a necessary margin an SVC will also be needed in such a case as in Fig. 13. One must further have in mind that connecting a new melt shop to a “clean bus” is a rare case; the network is typically “polluted” close to the limit set by the utility already before the furnaces start to operate, for instance by the plant’s own rolling mill or by other heavy industries in the neighbourhood. Due to this fact, the last object to be switched into the network must generate a much lower disturbance than the general limit in order to be acceptable by the utility.

As in our three examples, there are several different standards regarding flicker and flicker measurements in use and valid in different countries. The different filament lamp types used (100 V or 240 V, etc.) also make a comparison between standards complicated. As a rule of a thumb, in order to provide a reference of typical flicker values in EAF installations, the following simple calculation may be used.

The standard procedure using a flicker meter of UIE/IEC-type is to compare the furnace short circuit level (or short circuit impedance) seen from PCC with the short circuit level at the PCC using the prediction formula (The **Pst** is a 10-minute integrated value):

$$Pst_{99\%} = Kst \times \frac{Ssc_{eaf}}{Ssc_n}$$

with

Kst = characteristic emission coefficient for Pst

Ssc_{eaf} = short circuit level of the arc furnace at the PCC

Ssc_n = short circuit level of the network at the PCC

The **Kst** value in the formula ranges from 45 to 85, depending on how “noisy” or unstable the furnace operation is expected to be.

Here it should be noted that, according to CIGRE, a normal accepted Pst95% reference value in a MV/HV power system is 1.0 and the correlation between Pst99% and Pst95% is 1.25 and as a conclusion, with furnaces used normally and a ratio below 50 between the two fault levels, unacceptable disturbance can be expected without use of an SVC.

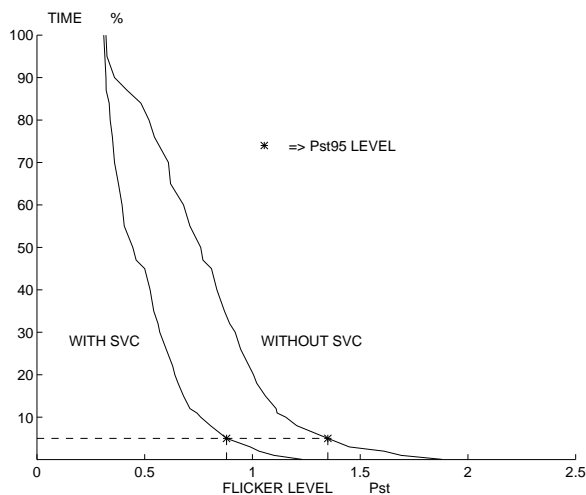
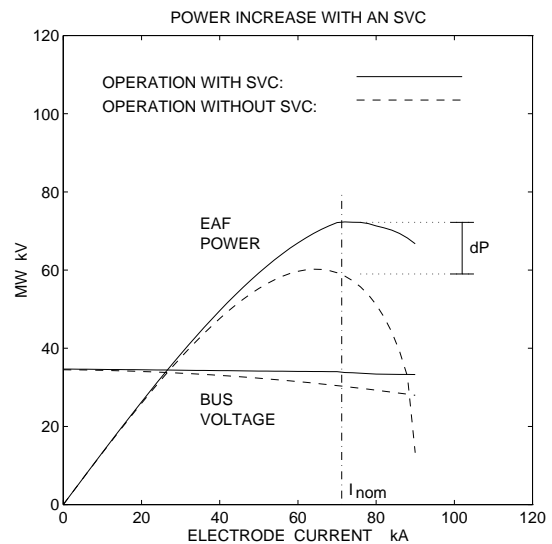

Fig. 14. Typical statistical registration of the flicker level and the use of the 95 % value.

4.2 Impact on steel production

If one follows the intention of decreasing the network voltage fluctuation by insertion of an SVC, there will also be benefits to the steel plant operator. In the diagram in Fig. 15 the positive influence of an almost stiff network is clearly visible. In this example, the active power increase will be in the range of 15 % if an SVC is used. The voltage decrease from no-load to the rated arc current will be approximately 5-6 % (which is less than in our second example), without



the SVC.

Fig. 15.

An attempt to correct the furnace bus voltage quality by insertion of a tremendously oversized step-down transformer may help the furnace operation but will in turn create unacceptably high flicker at PCC and thus this is not a practical solution.

- **Advantages of higher active power availability**
The possibility of using more power in an existing (or revamped) furnace with no need to make changes to the existing transformer and secondary system may vary between steel mills for commercial reasons. Here we wish to point out the use of power increase to shorten the tap-to tap time, as can be seen in Fig. 16.

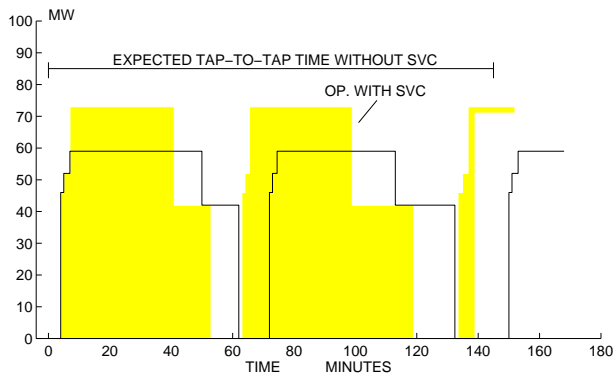

Fig. 16. A furnace load cycle without and with SVC.

The positive change in the melt down time can simple be calculated based upon the old formula:

$$t_m = \frac{W_{liq}}{\eta_{scr}} \times \frac{E \times 60 \times 10^{-3}}{S_{rated} \times \cos \phi \times \eta_{ut}}$$

with

t_m = Melt down time (min)

W_{liq} = Charge weight, liquid steel (tons)

η_{scr} = Yield factor, liquid/scrap

E = Energy consumption (kWh/ton)

S_{rated} =

Furnace transformer rating power (MVA)

$\cos \phi$ = Power factor

η_{ut} = Power utilization factor (Pmean/Prated)

with typical figures using the example above one has

$$t_{1m} = \frac{135}{0.9} \times \frac{465 \times 60 \times 10^{-3}}{59 \times 0.85} = 83.4 \text{ min}$$

$$t_{2m} = \frac{135}{0.9} \times \frac{465 \times 60 \times 10^{-3}}{73 \times 0.85} = 67.4 \text{ min}$$

This represents a decrease of approximate 16 min!

If this steel plant with an expected tap-to-tap time of 145 min prefers to use all the extra power in the production, at least one extra charge per day can be made, which means an increased annual production of around 50 000 tons.

- **Electrode savings**

Due to the decreased tap-to-tap time the electrode consumption will also decrease. In this case the furnace operates with the same electrode current, which means that a linear reduction of 12 to 15 % can be expected, typically corresponding to 0.5 kg/ton.

- **Energy savings**

With shorter operating time and with a more stable arc due to the stiffer network, the losses in the furnace, as well as in the auxiliary systems (fans and pumps, etc.) will decrease and approx. 20 kWh/ton can be expected to be saved.

- **Refractory savings**

With the more efficient and stable arcing a decrease in refractory wear will be expected. In this type of installation a decrease of 0.8 to 1.0 kg/ton has been reported.

4.3 Series reactor and long arc practice

Modern EAFs have a tendency to be more and more powerful, with higher ratings in the furnace transformers, and are of the so-called UHP type. To operate this type of furnace with low secondary voltages, according to previous practice would have led to a drastic increase in the arc current, resulting in additional electrode consumption and costs for a more robust furnace secondary system e.g. involving arms and cables. A more suitable method of increasing the furnace power is to increase the secondary voltage but keep the current at the previous values. Due to the very non-linear resistance characteristic in the arc, many of these UHP furnaces suffer from poor arcing due to operation with too high a power factor, causing difficulties in reigniting the arc after voltage zero crossing. In addition to the losses in the furnaces, the unstable arcing also gives flicker and harmonic current generation to the feeding network.

Installation of a furnace series reactor will normally improve the situation for the furnace operator by decreasing the cost per produced ton of steel and for the utility by decreasing the voltage fluctuation thanks to the arc stabilizing effect of the reactor.

The Fig. 17 below illustrates a case with a furnace transformer equipped with voltage taps hardly operable due to unstable arc. In this case, an increase in production was of minor interest due to other limitations in the network, but with the insertion of series reactor together with the stiffer network effect given by an SVC, a radical decrease in the electrode current is possible.

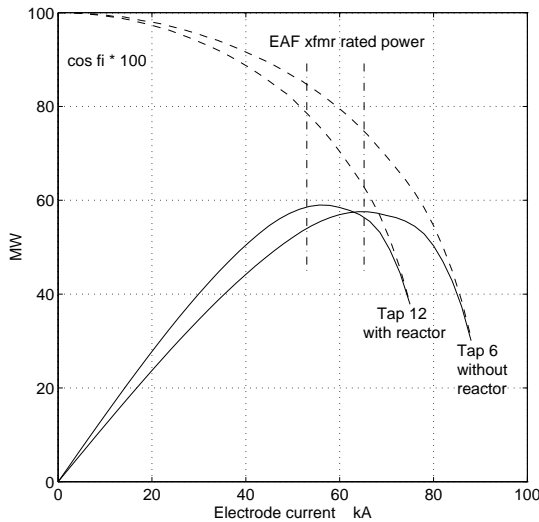

Fig. 17.

The positive influence of the decreased electrode current can be determined by dividing the main part of the electrode consumption into the two components below.

- **side oxidation**, mainly dependent on the furnace tap-to-tap time (as per section 4.2)
- **tip consumption**, mainly dependent on the second power of the electrode current

Typically, 30 to 70 % of the total electrode consumption can be referred to tip consumption and thus figures in the higher range represent the modern UHP furnace.

The tip consumption may be calculated as

$$W_{tip} = k_{tip} \times \int_0^T I_{rms}^2 dt$$

k_{tip} = the fraction of the total consumption

In our case (Fig. 17), with almost identical power and tap-to-tap time, the side oxidation should be equal and the difference in the total electrode consumption due to tip consumption only can be calculated by the formula:

$$\frac{W_{tap6} - W_{tap12}}{W_{tap6}} = k_{tip} \times \left(1 - \left(\frac{I_{tap12}}{I_{tap6}} \right)^2 \right)$$

or with a k_{tip} typical set to 0.5

$$\frac{W_{tap6} - W_{tap12}}{W_{tap6}} = 0.5 \times \left(1 - \left(\frac{53}{65} \right)^2 \right) = 0.168$$

This means a more than 16 % decrease in electrode consumption and in the actual example amounts to approximately 3.5 kg/ton consumption, a decrease of 0.5 kg/ton. The money savings resulting from this lower consumption are not insignificant. The lower electrode current will, in addition to the immediate advantage of electrode saving, also decrease power losses in the secondary system, in this case by approximately 2 MW or 15 kWh/ton.

4.4 DC EAFs and advantages of a stiffer network

Even if the example in section 4.1 shows an EAF of AC type similar results will occur with a furnace of DC type.

Without an SVC, it is most likely that a higher rated furnace transformer must be installed, resulting in higher reactive power consumption. The lower power factor, in turn, imposes a need for more power factor correction equipment, followed by increased over-voltage problems in no-load condition, etc. However, the capacitor power needed in the form of filters to correct the EAF harmonic current generation (in the furnace as well as in the rectifier), may already create such an overvoltage situation that the installation of an SVC becomes absolutely necessary.

It should further be noted, that in the case of DC furnaces increasing the smoothing reactor to attenuate flicker is not as favourable as in the AC furnace case due to the high increase in active power losses.

Pay-off calculation	without SVC	with SVC
<ul style="list-style-type: none"> Production increase 		
Tap-to-tap time (min)	145	129
Number of charges per day (at 135 ton)	≈10	≈11
Production ton/year (325 days)	435 000	485 000
Increase		50 000
Profit with 40 USD/ton		2 000 000 USD
<ul style="list-style-type: none"> Electrode savings 		
Consumption savings		0.5 kg/ton
Profit at 3.5 USD/kg		Σ 242 500 kg 849 000 USD
<ul style="list-style-type: none"> Energy savings 		
Consumption savings		20 kWh/ton
Profit at 0.03 USD/kWh		Σ 9 700 MWh 291 000 USD
In all		3 140 000 USD
Compared with a typical SVC cost turnkey, installation including civil works		≈4 000 000 USD
Pay-off time (4.0/3.1)		≈15 months

Table I

As for the AC furnace, a decrease in the tap-to-tap time through a higher power input or a lower electrode current made possible by a stiff network voltage will have a positive economic effect.

5. ECONOMIC ASPECTS

In the simplified pay-off calculation in Table I above, we wish to demonstrate the typical economic benefits with an SVC. The calculations are in principle, based upon one of the examples in section 4.2. Savings in refractory material are not included, and these may be added as a further benefit.

6. SUMMARY

To summarize, in addition to lower power bills with more favourable rates, the installation of the SVC has a direct impact on several production parameters such as:

- Increase in the available melting power which leads to a shorter melt down time and thus higher productivity.

- Decrease in specific electrode consumption due to the shorter melt down time and further by the more stable arc.
- Decrease in specific energy consumption due to lower radiation losses. Further the lower losses in the involved auxiliary systems (fans and pumps) and in the power supply system (for instance step down transformers) are significant.

REFERENCES

- [1] L. Hultqvist and A. Wilk-Wilczynski "Voltage Criteria in Steel Mill Networks" Publ. ISS 53rd Electric Furnace Conference - Nov. 95
- [2] S. Torseng "Shunt-connected reactors and capacitors controlled by thyristors" IEE PROC. Vol 128 Pt. C. No. 6. Nov. 1981
- [3] SVC for voltage stabilization and harmonic suppression in ladle furnace rolling mill ABB Pamphlet A02-0132 E
- [4] Static Var Compensation of AC and DC furnaces in joint operation ABB Pamphlet A02-0143 E