

1

2

3

4

5

6

A

B

C

D

A

B

C

D

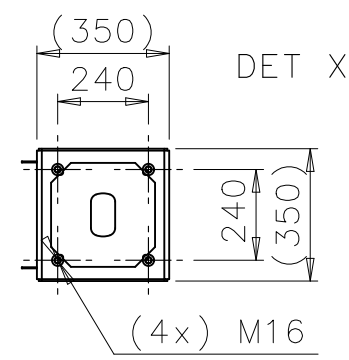
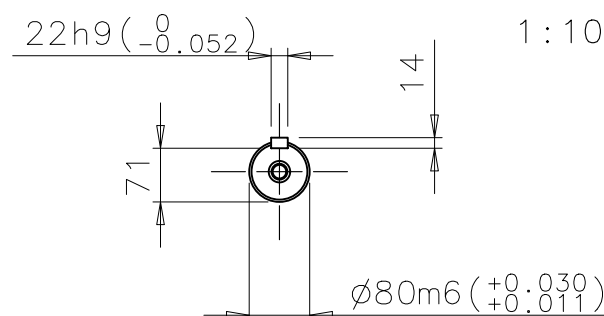
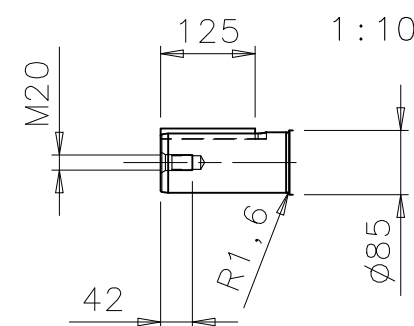

1	D-BEARING	6317M/C3
2	N-BEARING	6317M/C3 INSULATED 6317M/C3 (OPTIONAL)
3	TERMINAL BOX FOR CONTROL CAPLE 10-14, 2xM20x1,5 LARGER TERMINAL BOX (OPTIONAL)	
4	SPM NIPPLE DE AND NDE	
5	PT-100 FOR BEARINGS (OPTIONAL)	
6	INTERMEDIATE BOX	
7	FREE DISTANCE FOR COOLING	
8	TERMINAL BOX FOR HEATING ELEMENT CAPLE 10-14, 1xM20x1,5 (OPTIONAL)	
9	GREASING NIPPLE DE AND NDE	
10	EARTHING, M12, FOR M3GM MAX 150mm ²	
11	TRANSPORTATION COVER, THREE (3) LEADS OUT 1.5m (5ft) SIX (6) LEADS OUT (OPTIONAL)	

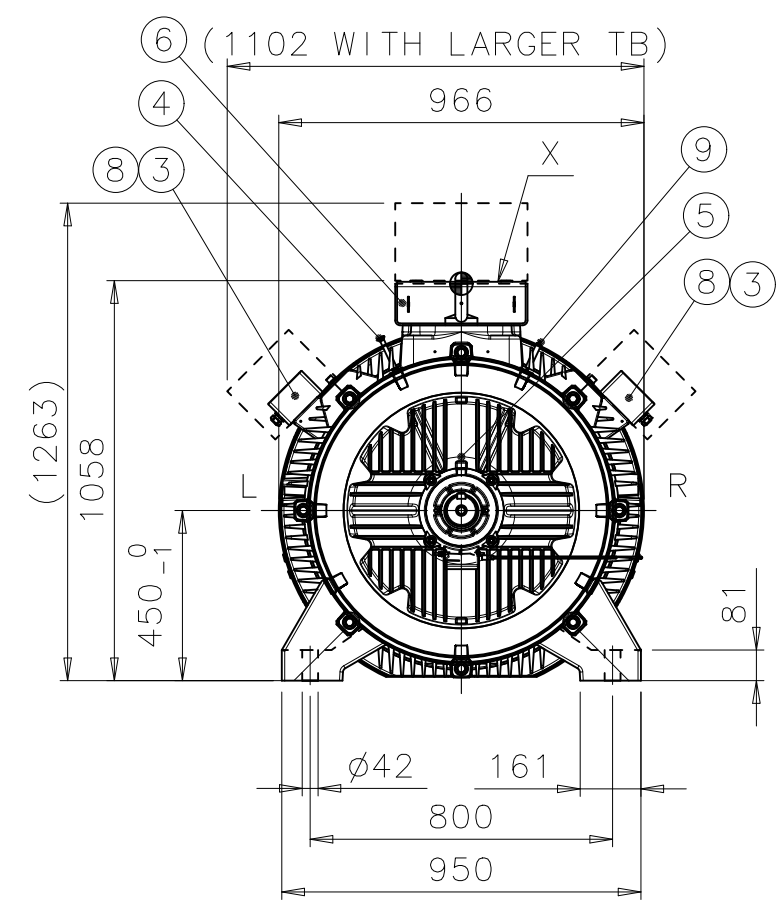
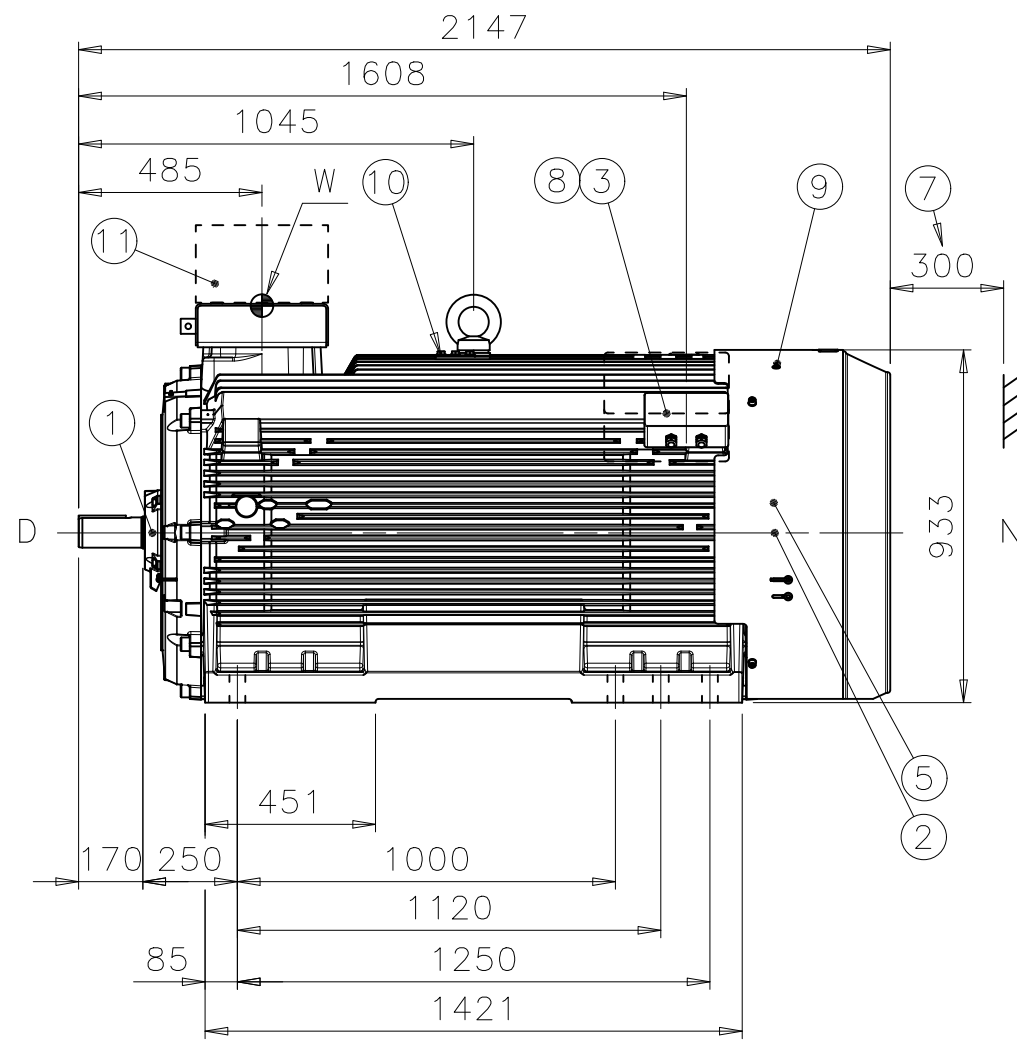

BEFORE COMMISSIONING, TERMINAL ARRANGEMENT SHALL BE SUCH THAT THE STATOR CONNECTION CABLES ARE COVERED WITH EARTHED PROTECTIVE STRUCTURE (E.G. MAIN TERMINAL BOX AND ADEQUATE INTERMEDIATE BOX).

MAIN TERMINAL BOXES ARE NOT INCLUDED IN MOTOR MANUFACTURER'S DELIVERY.

MAIN TERMINAL BOXES MUST FILL FOLLOWING REQUIREMENTS:
 - FOR EXPLOSIVE ENVIRONMENTS EX CERTIFIED
 - ENCLOSURE IP55 OR HIGHER ACC. TO SITE CONDITIONS

MAXIMUM MASS FOR MTB ASSEMBLY 600 kg,
 MAXIMUM MOMENT FROM MTB ASSEMBLY ACCORDING TO POINT W 1600Nm.

DURING THE INITIAL INSTALLATION PLACE 2mm SHIMS UNDER THE FEET OF THE MOTOR. THE CUSTOMER IS RESPONSIBLE FOR THE DESIGN AND CONSTRUCTION OF THE FOUNDATION. IT SHALL BE SUFFICIENTLY RIGID TO WITHSTAND SHORT CIRCUIT FORCES. TO AVOID RESONANCE VIBRATIONS THE FOUNDATION SHALL BE DESIGNED SO THAT THE NATURAL FREQUENCY OF FOUNDATION TOGETHER WITH MACHINE IS NOT WITHIN ±20% OF RUNNING SPEED FREQUENCY. THE CUSTOMER IS ALSO RESPONSIBLE FOR LATERAL AND TORSIONAL CRITICAL SPEED ANALYSIS OF THE COMPLETE INSTALLATION.

Rev	Change	Date	Prep.	Approved	Scale
Prepared	2006-09-08 M.VÄKIPARTA	Responsible dept.	ATAP/PID	Title	1:20
Approved	2006-09-08 O.LAHTINEN	Take over dept.		SQUIRREL CAGE MOTOR	
Material		Code	13 BM 450_IEC A / 450	Language	en
Supersedes	Superseded by	Type	M3BM/GM 450L2 B3	Size	A3
ABB Oy, Machines, Helsinki		Document No.	3GZF500045-82	Revision	Sheet
				A	1/1

1

2

3

4

5

6