

1

2

3

4

5

6

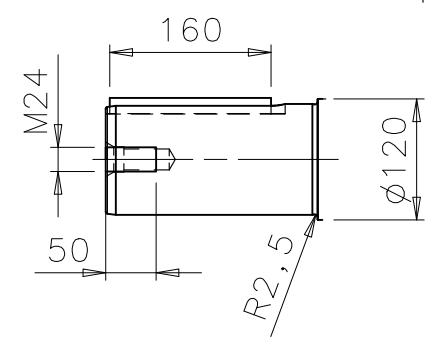

1:7.5

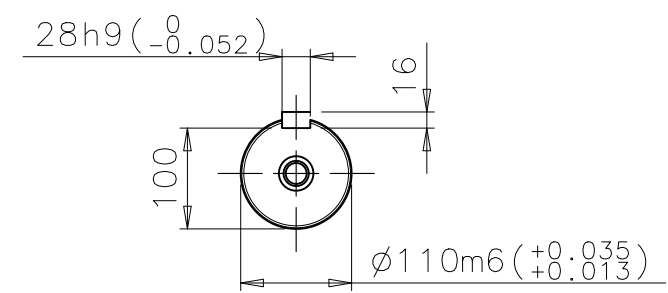

1:7.5

1	D-BEARING 6324/C3 NU324/C3 (OPTIONAL)
2	N-BEARING 6319/C3 INSULATED 6319/C3 (OPTIONAL)
3	TERMINAL BOX FOR CONTROL CABLE $\phi 10-14$, 2xM20x1,5 LARGER TERMINAL BOX (OPTIONAL)
4	SPM NIPPLE DE AND NDE
5	PT-100 FOR BEARINGS (OPTIONAL)
6	MAIN TERMINAL BOX
7	FREE DISTANCE FOR COOLING
8	TERMINAL BOX FOR HEATING ELEMENT CABLE $\phi 10-14$, 1xM20x1,5 (OPTIONAL)
9	GREASING NIPPLE DE AND NDE
10	EARTHING, M12, FOR M3GM MAX 150 MM ²
11	STAR POINT TERMINAL BOX (OPTIONAL)

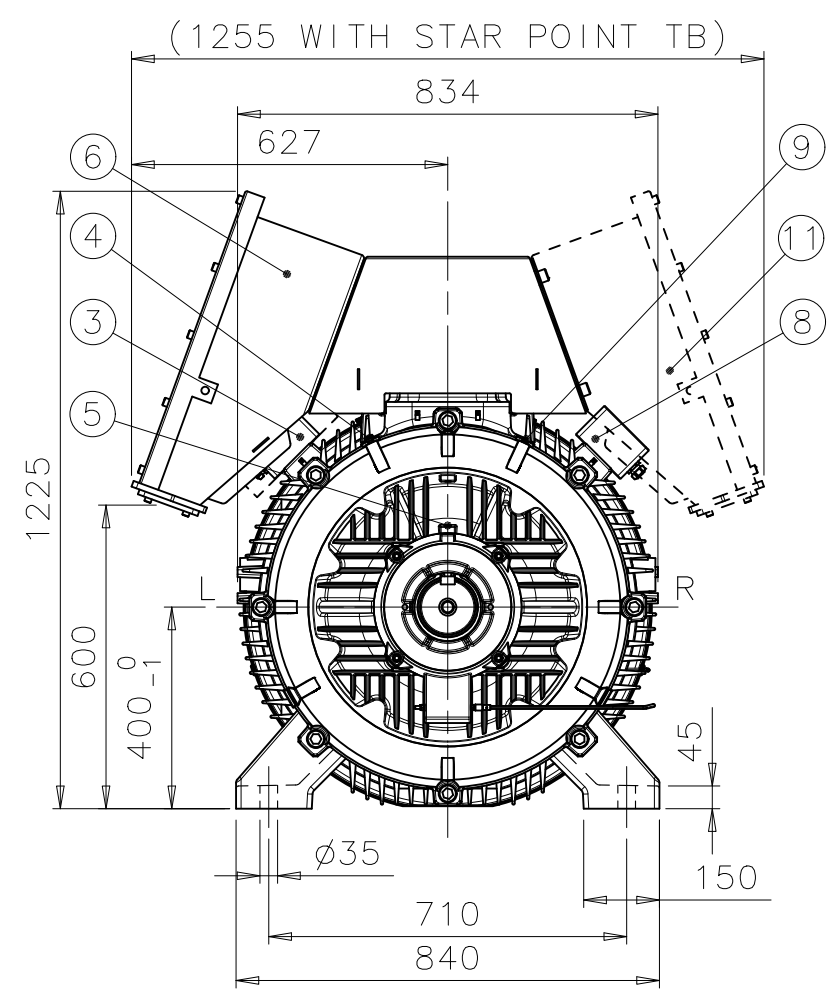
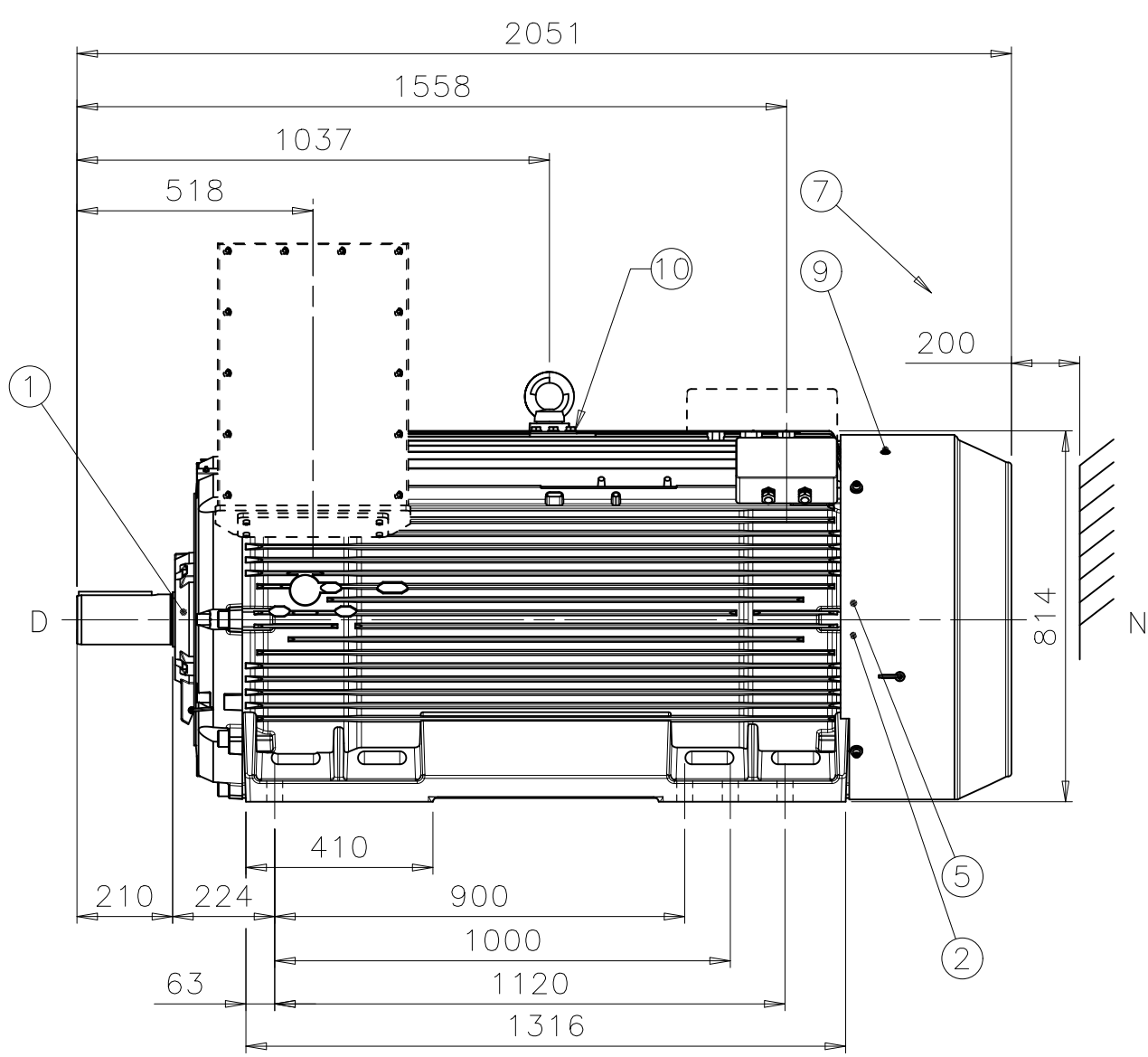

We reserve all rights in this document and in the information contained therein. Reproduction, use or disclosure to third parties without express authority is strictly forbidden.
© ABB Oy, Electrical Machines, Helsinki

General tolerances ISO 2768-mK
Threads according to ISO 965 tolerance class 6H
Symbols for roughness acc. to ISO 1302

DURING THE INITIAL INSTALLATION PLACE 2 mm SHIMS UNDER THE FEET OF THE MOTOR. THE CUSTOMER IS RESPONSIBLE FOR THE DESIGN AND CONSTRUCTION OF THE FOUNDATION. IT SHALL BE SUFFICIENTLY RIGID TO WITHSTAND SHORT CIRCUIT FORCES. TO AVOID RESONANCE VIBRATIONS THE FOUNDATION SHALL BE DESIGNED SO THAT THE NATURAL FREQUENCY OF FOUNDATION TOGETHER WITH MACHINE IS NOT WITHIN $\pm 20\%$ OF RUNNING SPEED FREQUENCY. THE CUSTOMER IS ALSO RESPONSIBLE FOR LATERAL AND TORSIONAL CRITICAL SPEED ANALYSIS OF THE COMPLETE INSTALLATION.

Rev	Change	Date	Prep.	Approved
Prepared	2006-08-22 A.MATTILA	Responsible dept.	ATDM/PID	Title
Approved	2006-08-22 O.LAHTINEN	Take over dept.		DIMENSION PRINT SQUIRREL CAGE MOTOR
Material		Code	13 BM 400 A / 400	Language
Supersedes	Superseded by	Type	M3BM/GM 400LK4-12 B3	Size
ABB ABB Oy, Electrical Machines, Helsinki		Document No.	3GZF500040-233	Revision
			A	Sheet
				1/1

1

2

3

4

5

6