

FUNCTIONAL DESCRIPTION

DOC01

Digital Operator Control

Prep.	10-11-30	Function Description			No. of p.	
Appr.	PA/R/ Bengt Persson	Approved	<i>DOC01</i> Functional Description		15	
Resp. dept.						
	ABB AB	Doc. no.	3AST 001 596D008	Lang. en	Rev. ind. I	Page 1

Contents

1	General	3
2	Configuration	3
3	Function Block DOC01	4
4	DOC01 Datatypes	5
4.1	DOC01_InPar.....	5
4.2	DOC01_OutPar.....	5
4.3	DOC01_Opr	5
5	Function	6
5.1	Basic Properties	6
5.2	Control Modes and Updating	6
5.2.1	E1	6
5.2.2	Manual.....	6
5.3	Alarm Functions	6
5.3.1	Event handling.....	7
5.4	Process connections	7
5.5	Interaction Window.....	7
5.5.1	DOC01 Interaction Window.....	7
5.5.2	General Parameters	7
5.5.3	Orders and Event.....	8
5.5.4	Text & Order Block	8
6	Operator Functions	9
6.1	Presentation	9
6.1.1	Display Elements	9
6.1.2	Time-logged Properties.....	10
6.2	Faceplate(Dialog)	11
6.3	Event Handling	13
6.3.1	General.....	13
6.4	Faceplate tabs.....	13
6.4.1	Block.....	13
6.4.2	Order Blocking	13
6.4.3	Info	14

1 General

DOC01 is a functional unit for a digital operator control in ControlIT, to be operated from OperateIT, Operator Station. DOC01 normally performs a complete function independently.

DOC01 has the following functions and properties:

Different control modes set by operator or by control logic.

Event handling of important control signals.

2 Configuration

DOC01 comprises a function block type for control and logic functions in Control^{IT}, a faceplate and an object Display in Operate^{IT} for operator functions and control parameters.

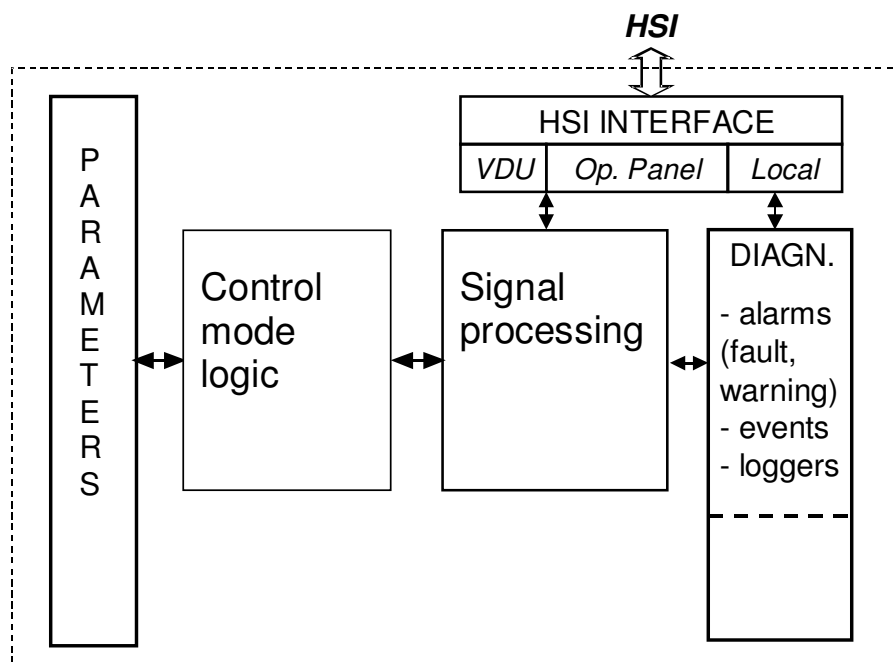

Figure 1. The Structure of the Functional Unit

3 Function Block DOC01

FUNCTION OF INPUT TERMINALS	DOC01		FUNCTION OF OUTPUT TERMINALS
Object name	Name	Value	Value
Object description	Description	Man	Man mode
Enable object	Enable	E1	E1 mode
E1 Reference	MV	OutPar	Out Parameter
Order mode to Man	SeqMan	Opr	Operator order
Order mode to E1	SeqE1		
In Parameter	InPar		
Event name	EventName		

Figure 3-1. Function Block Type, Complete symbol

Table 3-1 below illustrates the default properties of each terminal of the DOC01 function block.

Name	Data Type	Attributes	Direction	FD Port	Initial value	Description
Name	string	coldretain	in	yes	'DOC01'	Object name
Description	string	coldretain	in	yes	'Descr'	Object description
Enable	bool	coldretain	in	yes	true	Enable object
MV	bool	retain	in	yes		E1 Reference
SeqMan	bool	retain	in	yes		Order mode to Man
SeqE1	bool	retain	in	yes		Order mode to E1
InPar	DOC01_InPar	by_ref	in	yes		In Parameter
EventName	string	coldretain	in	yes	' DOC01_'	Event name
Value	bool	retain	out	yes		Value
Man	bool	retain	out	yes		Man mode
E1	bool	retain	out	yes		E1 mode
OutPar	DOC01_OutPar	by_ref	out	yes		Out Parameter
Opr	DOC01_Opr	by_ref	out	yes		Operator order

Table 3-1. Terminal properties.

4 DOC01 Datatypes

4.1 DOC01_InPar

Name	Data Type	Attributes	Initial value	ISP value	Description
Class	dint	coldretain	500		AE class
Severity	dint	coldretain	1000		AE severity
InitMode	dint	coldretain	5		Init mode (5 = Man ; 7 = E1)
ManBlk	bool	coldretain	false		Block operator order Man mode
E1Blk	bool	coldretain	false		Block operator order E1 mode
SeqManEvBlk	bool	coldretain	true		Block event for SeqMan
SeqE1EvBlk	bool	coldretain	true		Block event for SeqE1

4.2 DOC01_OutPar

Name	Data Type	Attributes	Initial value	ISP value	Description
Mode	dint	retain			Active mode
NormalMode	bool	retain			Normal mode (Active mode = Init mode)

4.3 DOC01_Opr

Name	Data Type	Attributes	Initial value	ISP value	Description
Man	bool	retain			Operator order Manual mode
E1	bool	retain			Operator order E1 mode
Ord_On	bool	retain			Operator order ON command
Ord_Off	bool	retain			Operator order OFF command

5 Function

5.1 Basic Properties

The DOC01 functional unit is designed for an operator entry of a digital signal.

DOC01 has the following basic functions:

- Control Modes and Updating.
- Error Handling.
- Event handling.
- Operator Functions.

5.2 Control Modes and Updating

The digital signal is read at intervals determined by the controllers task scan-time. You should set scan time to the requirements of your system.

The control modes can individually be blocked for operator access.

5.2.1 E1

E1 is the initial control mode of the DOC01, where the value is obtained from the input terminal: MV. The control mode E1 can be commanded from the operator's station. Enabling the blocking function from the interaction window blocks the E1 order.

The control mode E1 is activated by:

- Clicking on the E1 button on the operator's faceplate. E1 is indicated on the object Display and Faceplate.
- A program activating the input terminal: SeqE1.

5.2.2 Manual

In this mode the operator directly sets the output value from the operator station. Enabling the blocking function from the interaction window blocks the Man order.

The control mode MAN is activated by:

- Clicking on the Man button on the operator's faceplate activates the control mode MAN. Man is indicated on the object Display and on the Faceplate.
- A program activating the input terminal: SeqMan.

5.3 Alarm Functions

The DOC does not have any alarm function.

5.3.1 Event handling

Event are generated for status change on the signals defined in interaction window in chapter 4.5.3

The layout of the event is described in chapter 6.3 Event Handling.

All Operator Events are reported by Audit Trail Functionality and not included in the FunctionBlock.

The individual text string for each event is stored in the Alarm and Event Translator aspect. This text can be NLS handled.

5.4 Process connections

The DOC01 is connected to the process via the following terminals.

- Value Connection for output value e.g. to operate a software switch.
- MV External Reference is connected here.

5.5 Interaction Window

The interaction window is available in the Control^{IT} Control Builder. The interaction window is an engineering aid used to simplify configuration and blocking of signals not available on the faceplates. Changes to values in the Interaction window are only available in 'Online' mode in Control^{IT}.

5.5.1 DOC01 Interaction Window

Interaction window overview. Name and description are shown. The buttons are links to sub-windows.

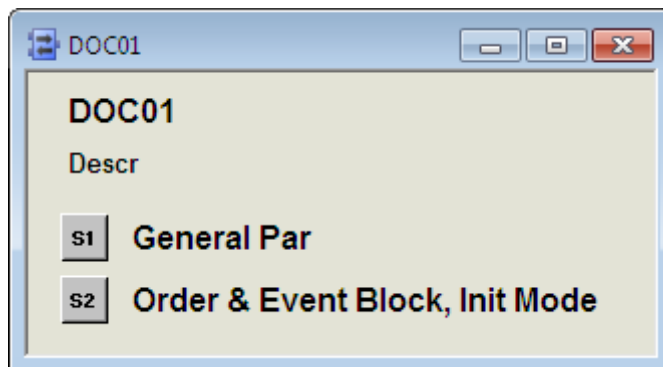
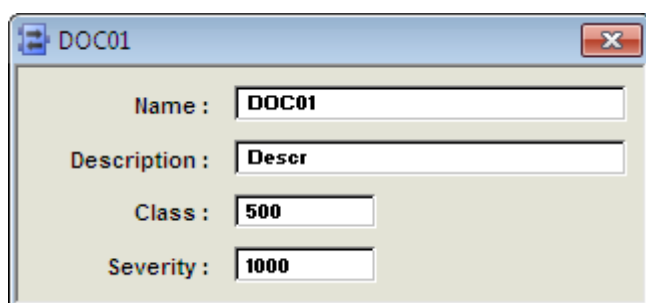

Figure 4-1 Main Interaction Window.

5.5.2 General Parameters

'Class' defines the 'process section' or area in which alarms are grouped. By utilizing 'class' the alarms can be filtered. Valid values are user defined. A suggestion would be to use mill area numbers as class values.

'Severity' defines the alarm priority. Valid values are 1 –1000 where 1 is the lowest priority.



DOC01

Name :

Description :

Class :

Severity :

Figure 4-2 General Parameters.

5.5.3 Orders and Event

Order Block:

“Manual Mode” blocks the input signal. A value can then be entered from faceplate. Mode is Man.

“E1 mode” reads the input signal MV and displayed the value on the faceplate. Mode is E1.

A 1 will remove the possibility to select the mode form the faceplate

Init Mode define the mode of the object when is started in Cold start

Event Block is used for blocking the event message. A 1 will block the event message.

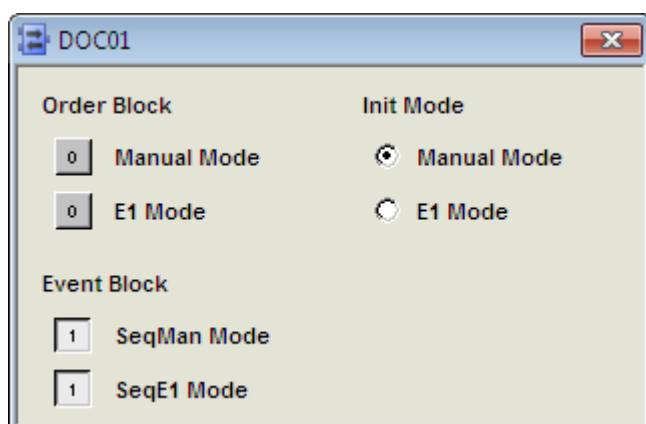

DOC01

Order Block

Manual Mode

E1 Mode

Init Mode

Manual Mode

E1 Mode

Event Block

SeqMan Mode

SeqE1 Mode

Figure 4-3 Orders and Events

5.5.4 Text & Order Block

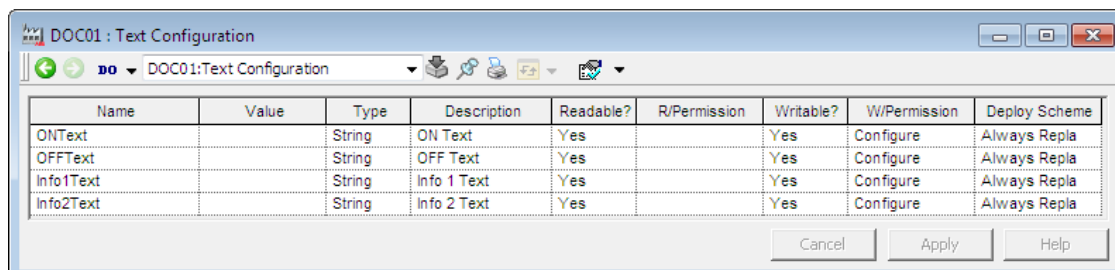

Name	Value	Type	Description	Readable?	R/Permission	Writable?	W/Permission	Deploy Scheme
ONText		String	ON Text	Yes		Yes	Configure	Always Repla
OFFText		String	OFF Text	Yes		Yes	Configure	Always Repla
Info1Text		String	Info 1 Text	Yes		Yes	Configure	Always Repla
Info2Text		String	Info 2 Text	Yes		Yes	Configure	Always Repla

Cancel Apply Help

Figure 4-4 Text

6 Operator Functions

The Operator functions are divided in principle into 3 parts:

Presentation (Display elements, Time logged properties)

Faceplate (Dialog)

Alarm and Event handling

6.1 Presentation

6.1.1 Display Elements

Display elements, which can be used for different display types, are available for use in the functional unit DOC01.

The display elements show the status and the controls of the process with different degrees of detail and are intended for the following displays:

Object display

Process display

Examples of different display elements, which could be used, are given in the following sections.

6.1.1.1 Object Display

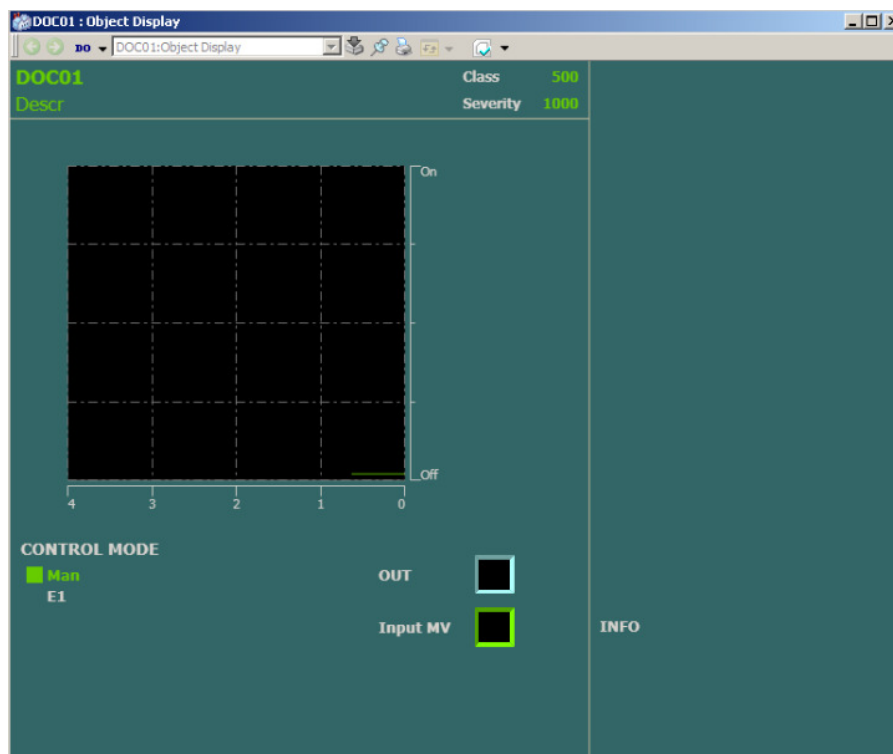

Figure 5-1 Object Display.

6.1.1.2 Process Display

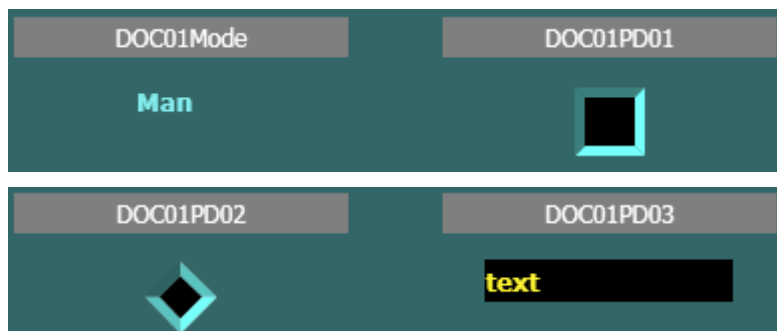

Figure 5-2 Process Display Elements.

6.1.2 Time-logged Properties

Digital values stored can be presented graphically in the form of traces on the display screen. Such a display, a Trend Display, can consist of 1- 4 traces as standard. All properties for the object DOC01 are available to be logged on the trend curves.

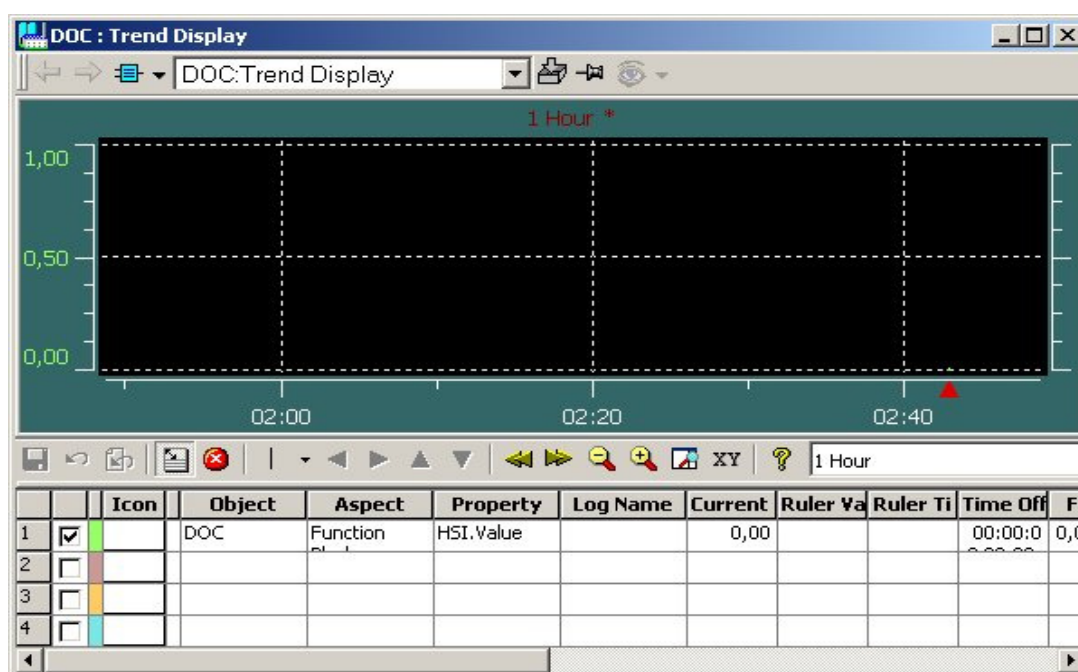

Figure 5-3 Trend Curve

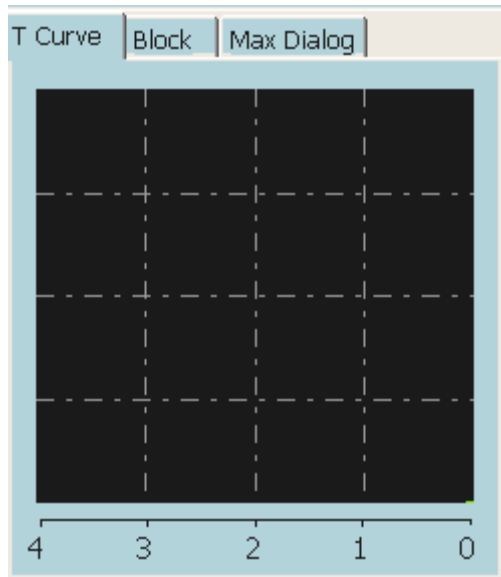

Figure 5-4 Extended Faceplate (T Curve)

6.2 Faceplate(Dialog)

The display screen is supplemented with a mouse and keyboard for operator communication with the functional unit/object.

By using Operate^{IT} Operator Station the operator can view and control the process through faceplates. The dialogue consists of buttons, indicators and graphic presentations within a Faceplate. A faceplate has three levels of dialogue, which are presented by the following three runtime views:

Reduced Faceplate, where the size and contents typically have been optimized to cover most of the normal process operator actions. Minimum dialogue. This is the default view.

Faceplate, which typically covers all normal process operator actions. This view is disabled as default.

Extended Faceplate, with functions and information intended for the process engineer or the advanced operator. Maximum dialogue.

The figures 5-5 to 5-7 below illustrate the various presentations of the faceplate.

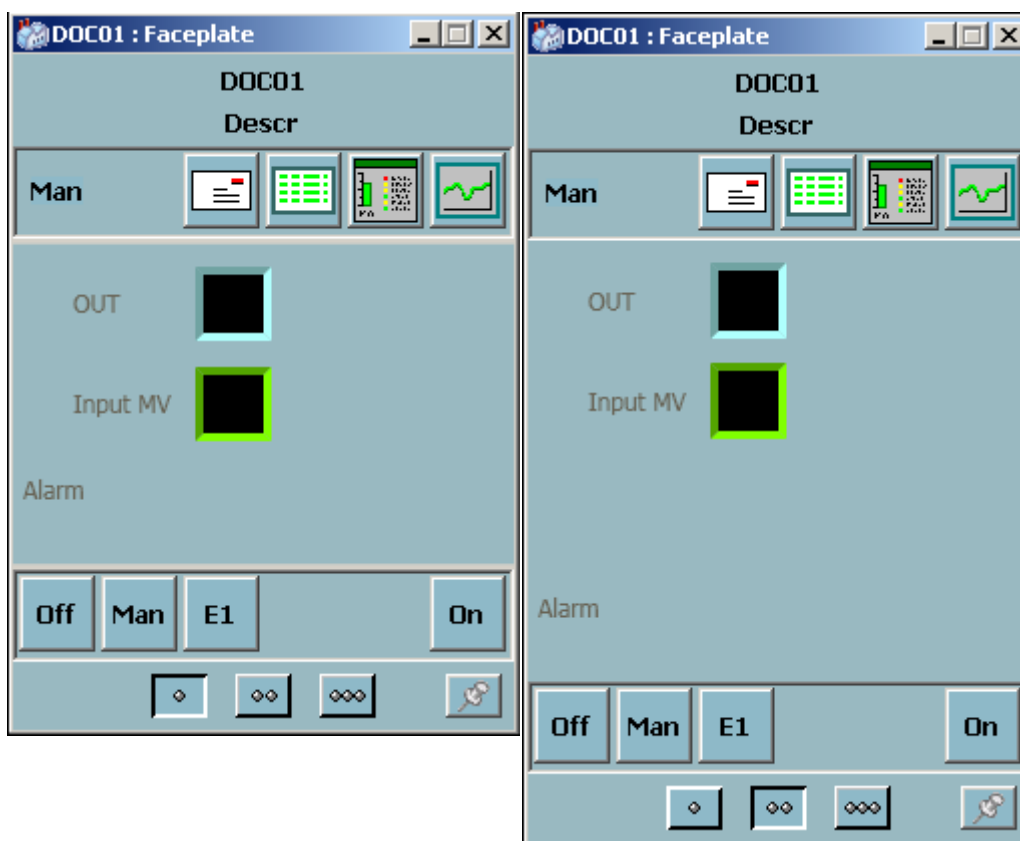

Figure 5-5 Reduced Faceplate. Figure 5-6 Faceplate.

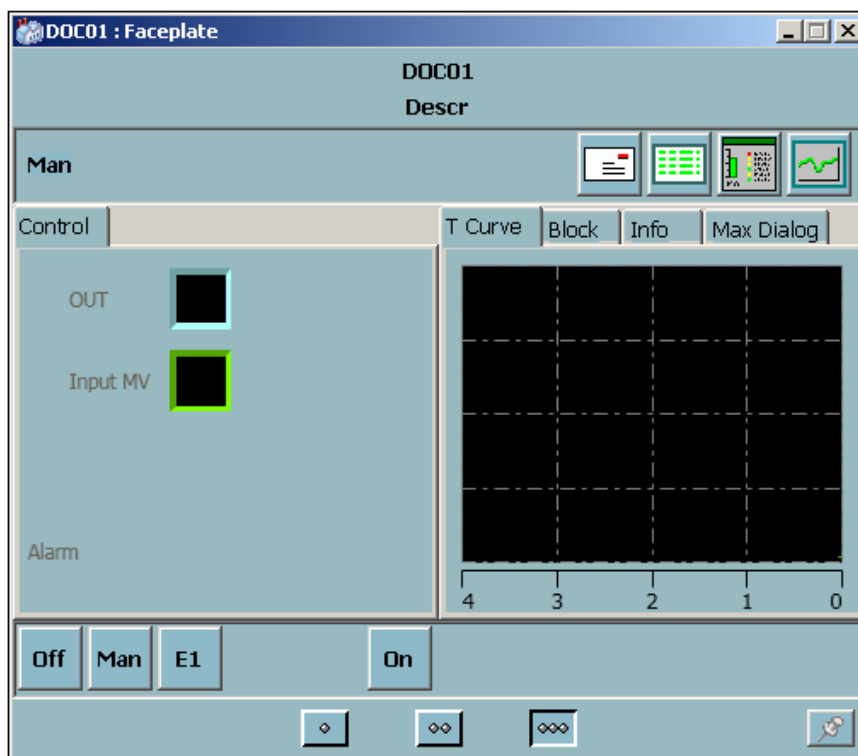

Figure 5-7 Extended Faceplate

6.3 Event Handling

6.3.1 General

This section contains a description of all alarms and events in the functional unit DOC01.

When an output value changes state an event is generated and can be viewed on the Operate^{IT} Operator Station. The events are indicated in the event list.

The following Event texts are generated by the functional unit DOC01. The “Message Description” text are stored in the Alarm and Event Translator aspect and can be NLS handled.

Source Name	Object Description	Condition	Message Description
<Name>	<Description>		SeqMan Mode
<Name>	<Description>		SeqE1 Mode

6.4 Faceplate tabs

6.4.1 Block

The check box “Enable Object”, is used to set the object out of service.

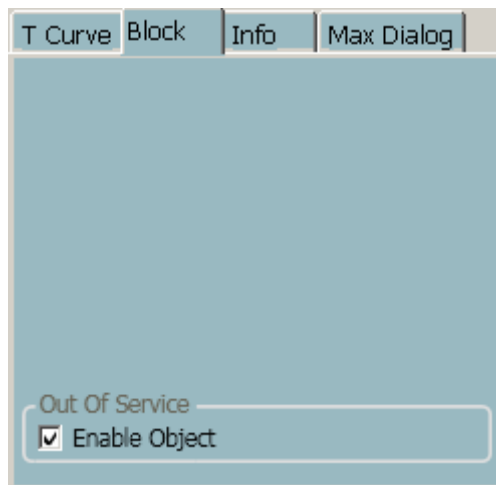

Figure 5-8 Extended Faceplate (Block)

6.4.2 Order Blocking

By using the extended faceplate it is possible for the process engineer to limit the operator access to different control modes.

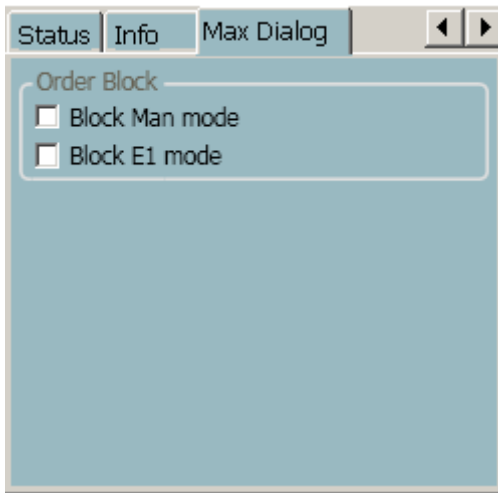

Figure 5-9 Extended Faceplate (Max Dialog)

6.4.3 Info

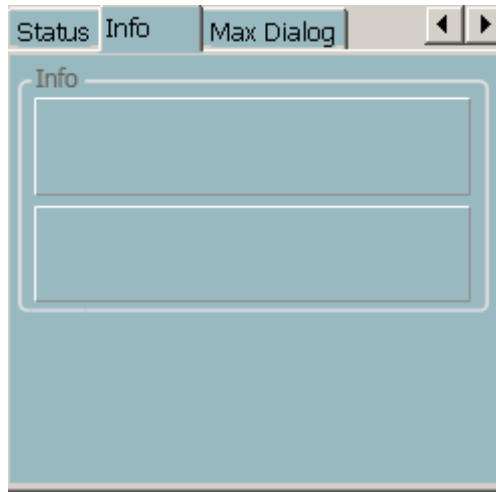

Figure 5-10 Extended Faceplate (Info)

REVISION

Rev.	Page (P) Chapt. (C)	Description	Date Dept./Init.
A		Release 2.0	030212/MP
B		Orderblock added	031106/MP
C	5, 6	Initialization	04-04-14/FM
D		Rev 3.1/2	050223/MP
E	4,5	Event handling is added. Update of faceplate and Interaction Window elements	050324/BP
F	5	Faceplate, Rev 4.0/1	05-08-25/MP
G	3	Param connection removed rev 4.0/5	070511/BP
H		Rev 5.0-1	081230/BP
I		Update rev 5.1/0	101102/BP