

FUNCTIONAL DESCRIPTION

Total01 Totalizer

Prep. /	10-11-30	Function Description			No. of p.
Appr. PA/R/ Bengt Persson	Approved	Total01 Functional Description			12
Resp. dept.					
 ABB AB		Doc. no. 3AST 001 596D009	Lang. en	Rev. ind. F	Page 1

Contents

1	General	4
2	Configuration	4
3	Function Block TOTAL01	5
4	TOTAL01 Datatypes.....	6
4.1	TOTAL01_InPar	6
4.2	TOTAL01_OutPar	6
4.3	TOTAL01_Opr.....	6
5	Function.....	7
5.1	Basic Properties	7
5.2	Control Modes and Updating	7
5.2.1	E1	7
5.2.2	Hold	7
5.3	Scaling and Engineering Units.....	7
5.4	Process connections	7
5.5	Interaction Window.....	8
5.5.1	Total01 Interaction Window.....	8
5.5.2	General Parameters	8
5.5.3	Order & Event Block	8
5.5.4	Parameters.....	9
6	Operator Functions.....	10
6.1	Presentation	10
6.1.1	Display Elements	10
6.2	Faceplate(Dialog)	11
6.3	Event Handling	11

1 General

TOTAL01 is a functional unit for a totalizer. A TOTAL01 normally performs a complete function independently.

Resetting of totalizer is available from operators station.

TOTAL01 has the following functions and properties:

Different control modes set by operator or by control logic.

Limiting of output signal.

2 Configuration

TOTAL01 comprises a function block type for control and logic functions in Control^{IT}, a faceplate and an object display in Operate^{IT} for operator functions and control parameters.

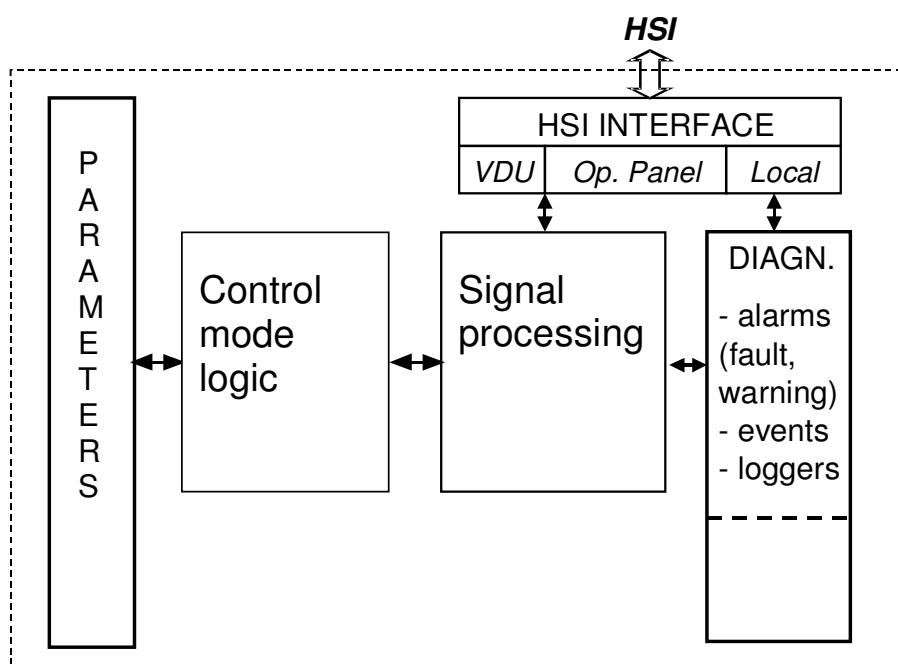

Figure 1. The Structure of the Functional Unit

3 Function Block TOTAL01

FUNCTION OF INPUT TERMINALS	TOTAL01		FUNCTION OF OUTPUT TERMINALS
Object name	Name	Q	Total for this period
Object description	Description	Q_Prev	Total for previous period
Enable object	Enable	HoldInd	Man mode
Measured Value	MV	E1	E1 mode
Bias	Scale	SignalErr	Error
MV status	InputErr	OutPar	Out Parameter
Integration Time	TI	Opr	Operator order
Reset (Q value is moved to Q_Prev)	Reset		
Order mode to Man	SeqHold		
Order mode to E1	SeqE1		
In Parameter	InPar		
Event name	EventName		

Figure 3-1. Function Block Type, Complete symbol

Table 3-1 below illustrates the default properties of each terminal of the TOTAL01 function block.

Name	Data Type	Attributes	Direction	FD Port	Initial value	Description
Name	string	coldretain	in	yes	'Total01'	Object name
Description	string	coldretain	in	yes	'Descr'	Object description
Enable	bool	coldretain	in	yes	true	Enable object
MV	real	retain	in	yes		Measured Value
Scale	real	coldretain	in	yes	1.0	Bias
InputErr	dword	retain	in	yes	16#C0	MV status
TI	time	coldretain	in	yes	1h	Integration Time
Reset	bool	retain	in	yes		Reset (Q value is moved to Q_Prev)
SeqHold	bool	retain	in	yes		Order mode to Man
SeqE1	bool	retain	in	yes		Order mode to E1
InPar	Total01_InPar	by_ref	in	yes		In Parameter
EventName	string	coldretain	in	yes	' Total01_'	Event name
Q	real	coldretain	out	yes		Total for this period
Q_Prev	real	coldretain	out	yes		Total for previous period
HoldInd	bool	retain	out	yes		Man mode
E1	bool	retain	out	yes		E1 mode
SignalErr	bool	retain	out	yes		Error
OutPar	Total01_OutPar	by_ref	out	yes		Out Parameter
Opr	Total01_Opr	by_ref	out	yes		Operator order

Table 3-1. Terminal properties.

4 TOTAL01 Datatypes

4.1 TOTAL01_InPar

Name	Data Type	Attributes	Initial value	ISP value	Description
Class	dint	coldretain	500		AE class
Severity	dint	coldretain	1000		AE severity
Unit	string[10]	coldretain	"		Totaliser Unit
Dec	dint	coldretain	1		Totaliser Decimal
MVUnit	string[10]	coldretain	"		MV Unit
MVDec	dint	coldretain	1		MV Decimal
InitMode	dint	coldretain	7		Init mode (7 = E1 ; 11 = Hold/Man)
HoldBlk	bool	coldretain	false		Block operator order Hold mode
E1Blk	bool	coldretain	false		Block operator order E1 mode
ResetBlk	bool	coldretain	false		Block operator order Reset command
SeqHoldEvBlk	bool	coldretain	true		Block event for SeqHold
SeqE1EvBlk	bool	coldretain	true		Block event for SeqE1
ResetEvBlk	bool	coldretain	true		Block event for Reset
ErrCtrl	bool	coldretain	false		No error at overflow

4.2 TOTAL01_OutPar

Name	Data Type	Attributes	Initial value	ISP value	Description
Mode	dint	retain			Active mode
NormalMode	bool	retain			Normal mode (Active mode = Init mode)
AIErr	bool	retain			MV error

4.3 TOTAL01_Opr

Name	Data Type	Attributes	Initial value	ISP value	Description
Hold	bool	retain			Operator order Hold mode
E1	bool	retain			Operator order E1 mode
Reset	bool	retain			Operator order Reset command

5 Function

5.1 Basic Properties

The TOTAL01 functional unit can be connected to a analog input signal or internal variable that has to be totalized.

TOTAL01 has the following basic functions:

- Control Modes and Updating
- Scaling and Units
- Limit Check
- Operator Functions

5.2 Control Modes and Updating

The input signal is read at intervals determined by the controllers task scan-time. You should set scan time to the requirements of your system.

5.2.1 E1

E1 is the initial control mode of the TOTAL01, where the value is obtained from the variable at input terminal :MV.

The control mode E1 is activated by:

By clicking on the Rel button on the operator's faceplate.

Input terminal SeqE1 when activated by a pulse.

5.2.2 Hold

In this mode the operator directly sets the output value from the operator station.

Clicking on the Hold button on the operator's faceplate activates the control mode HOLD. Hold is indicated on the Faceplate.

Input terminal Hold when activated by a pulse.

5.3 Scaling and Engineering Units

All values are used in the system as engineering units. Using the interaction window enters Max, Min, Unit and Fraction (Decimal).

5.4 Process connections

The TOTAL01 is connected to the process via the following two input terminals.

- MV Connection for value to be totalized.
- Q Output from totalizer this period.
- Q_Prev Output from totalizer previous period.

5.5 Interaction Window

The interaction window is available in the Control^{IT} Control Builder. The interaction window is an engineering aid used to simplify configuration and blocking of signals not available on the faceplates. Changes to values in the Interaction window are only available in 'Online' mode in Control^{IT}.

5.5.1 Total01 Interaction Window

Interaction window overview. Name and description are shown. The buttons are links to sub-windows.

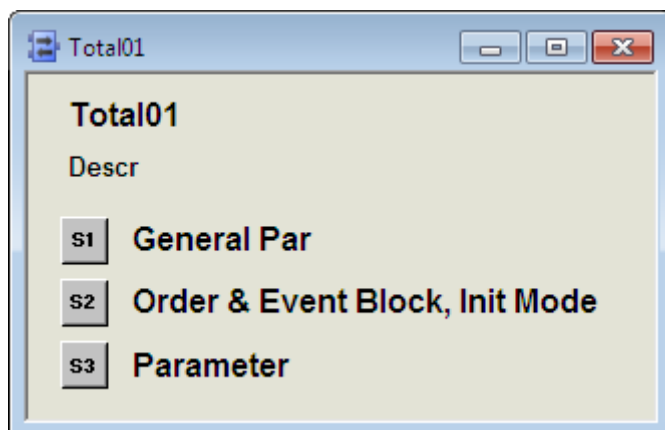

Figure 4-1 Main Interaction Window.

5.5.2 General Parameters

“Class” defines the process section or area in which alarms are grouped. By utilizing class the alarms can be filtered. Valid values are user defined. A suggestion would be to use mill area numbers as class values.

“Severity” defines the alarm priority for general alarms. Valid values are 1 –1000 where 1000 is the highest priority.

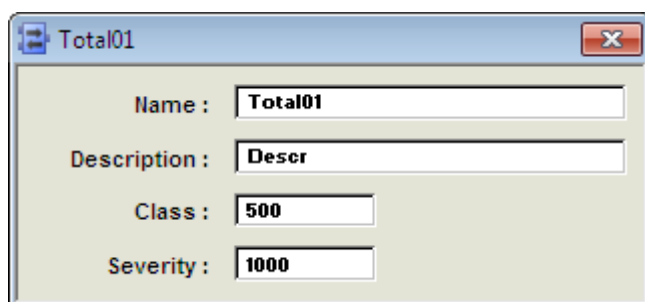

Figure 4-2 General Parameters.

5.5.3 Order & Event Block

Blocking of orders and events are entered in this window.

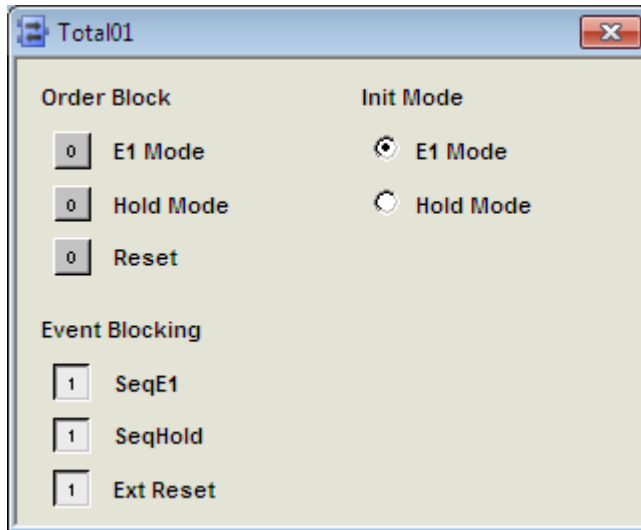

Figure 4-6 Order & Event Block.

5.5.4 Parameters

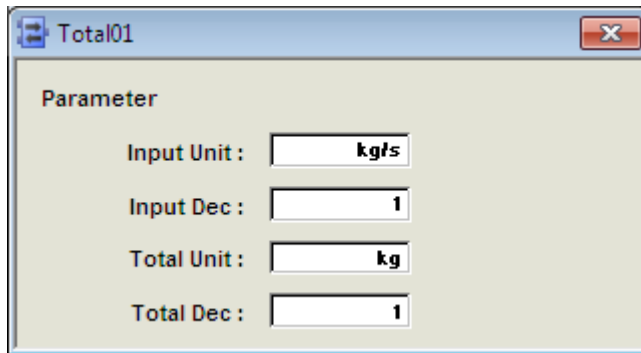

Figure 4-7 Units & Range.

6 Operator Functions

The Operator functions are divided in principle into 2 parts:

Presentation (Display elements)

Faceplate (Dialog)

6.1 Presentation

6.1.1 Display Elements

Display elements, which can be used for different display types, are available for use in the functional unit TOTAL01.

The display elements show the status and the controls of the process with different degrees of detail and are intended for the following displays:

- Process display

Examples of different display elements, which could be used, are given in the following sections.

6.1.1.1 Process Display

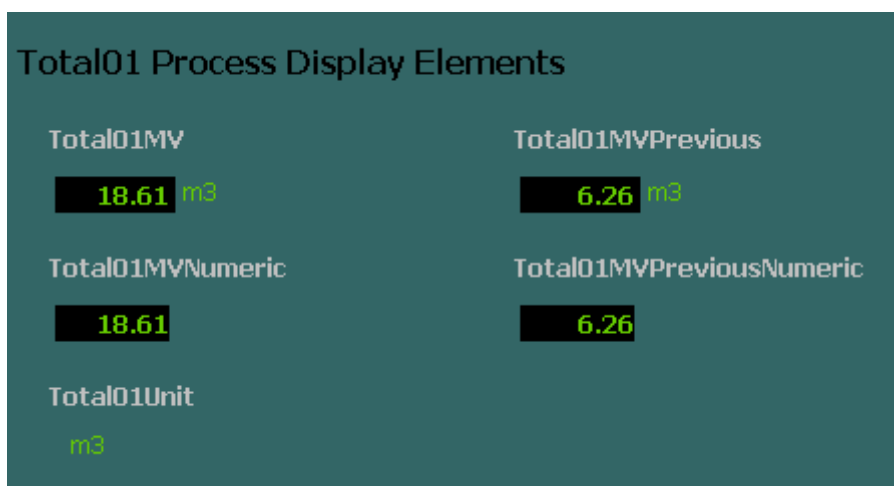

Figure 5-1 Process Display Elements.

6.2 Faceplate(Dialog)

The display screen is supplemented with a mouse and keyboard for operator communication with the functional unit/object.

By using Operate^{IT} Operator Station the operator can view and control the process through faceplates. The dialogue consists of buttons, indicators and graphic presentations within a Faceplate. A faceplate has three levels of dialogue, which are presented by the following three runtime views:

Reduced Faceplate, where the size and contents typically have been optimized to cover most of the normal process operator actions. Minimum dialogue. This is the default view.

Faceplate, which typically covers all normal process operator actions. This view is disabled as default.

The figures 5-2 to 5-3 below and overleaf illustrate the various presentations of the faceplate.

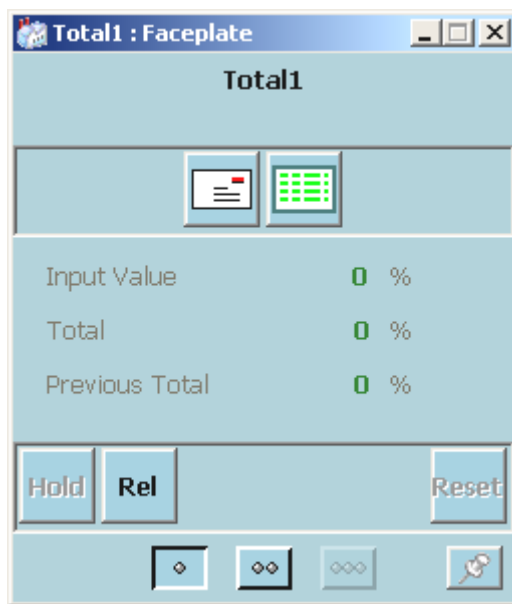

Figure 5-2 Reduced Faceplate.

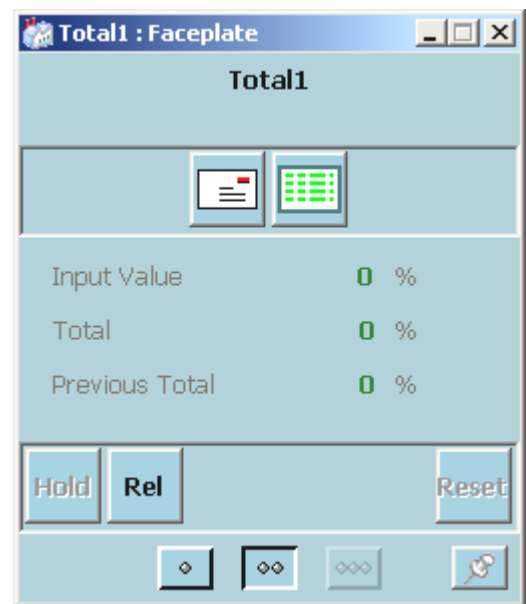

Figure 5-3 Faceplate.

6.3 Event Handling

The “Condition” text are stored in the Alarm and Event Translator aspect and can be NLS handled.

SourceName	ObjectDescription	Condition	Message Description
<Name>	<Description>		Ext Reset On
<Name>	<Description>		SeqHold Mode
<Name>	<Description>		SeqE1 Mode

REVISION

Rev.	Page (P) Chapt. (C)	Description	Date Dept./Init.
-		First release (2.0/0)	03-05-26/MP
A	5, 6	Initialization	04-04-15/FM
B	3	Rev 3.1/2	050319/MP
C	4,5	Event handling is added	050401/BP
D	4, 5	Faceplate, Rev 4.0/1	050902/MP
E	3	Param connection removed Rev4.0/5. Interaction window change	070511/BP
F		Update Rev 5.1/0	10!!03/BP