

FUNCTIONAL DESCRIPTION

MOT02

2 Speed or Reversing Motor

Prep. /	10-11-30	Function Description			No. of p.
Appr. PA/R/ Bengt Persson	Approved	MOT02			33
Resp. dept.					
	ABB AB	Doc. no.	Lang.	Rev. ind.	Page
		3AST 001 587D001	en	J	1

Contents

1	General	4
2	Configuration	4
3	Function Block MOT02	5
4	MOT02 Datatypes	8
4.1	MOT02_InPar.....	8
4.2	MOT02_OutPar.....	9
4.3	MOT02_Opr	10
5	Function	11
5.1	Basic Properties	11
5.2	Control Modes.....	11
5.2.1	JOG.....	11
5.2.2	LOCAL.....	12
5.2.3	MANUAL.....	13
5.2.4	EXTERNAL 1 and EXTERNAL 2	13
5.2.5	DISABLED.....	13
5.3	Ready for Start	13
5.4	Start-up	13
5.5	Interlocks.....	14
5.6	Start and Stop	14
5.6.1	Start and Stop Order at Different Motor Control Modes.....	15
5.6.2	Start Order Selection	15
5.6.2.1	Control mode JOG	16
5.6.2.2	Control mode LOCAL.....	16
5.6.2.3	Control mode MAN.....	16
5.6.2.4	Control mode Ext1/Ext2	16
5.6.2.5	Change of Direction/Speed	16
5.6.2.6	Control mode DISABLE.....	16
5.6.3	Operator Order and Order Blocking	16
5.7	Fault Evaluation in the Control Circuit.....	16
5.8	Supervision of Motor Current.....	17
5.9	Interaction Window.....	17
5.9.1	MOT02 Interaction Window.....	17
5.9.2	General Parameters	17
5.9.3	Order Block.....	18
5.9.4	Blocking of Alarm and Events	18
5.9.5	Interlock Settings	19
5.9.6	Current settings	20
5.9.7	Texts.....	21
5.9.8	Maintenance	22
6	Operator Functions	23
6.1	Presentation	23
6.1.1	Display elements	23
6.1.1.1	Object display	24
6.1.1.2	Process display.....	24
6.1.1.3	Interlock Display.....	24
6.1.1.4	Time-logged Properties	25
6.2	Faceplate (Dialog).....	26
6.3	Alarm and Event Handling.....	28
6.3.1	General.....	28
6.3.2	Alarm and Event Message.....	29

6.4	Faceplate Tabs	30
6.4.1	Alarm and Event blocking	30
6.4.2	Limits	31
6.4.3	Info tab	31
6.4.4	Maintenance	32

1 General

MOT02 is a functional unit designed for the control of motors in different processes.

The functional unit is standardised to a high degree to simplify the work of designing presentation, dialog and control logic. The unit has many optional capabilities, which increase its operational flexibility. MOT02 normally performs its control function without help from other elements.

MOT02 is used in the control of motors from Operate^{IT} Operator Station, control desks or control organs at the motor itself. The motor can be controlled from a master control function (e.g. group start, level regulation from level gauges etc).

2 Configuration

MOT02 like other functional units is built up of two parts:

- A Function Block, which is handled in the same way as other Function Blocks in the ABB Controller 800M range of products. Figure 3.1 illustrates the terminals on the function block.
- A section for operator functions, which consists of presentation and order functions. Data and parameters from the process are presented on an Operate^{IT} Operator Station. The keyboard of the Operate^{IT} Operator Station is used by the operator to enter commands which control the operation of the functional unit. The response to the operator's intervention is shown on the display screen of the Operate^{IT} Operator Station. The application work for this part is normally limited to the arrangement of the display. Figure 2.1 shows the structure of the functional unit.

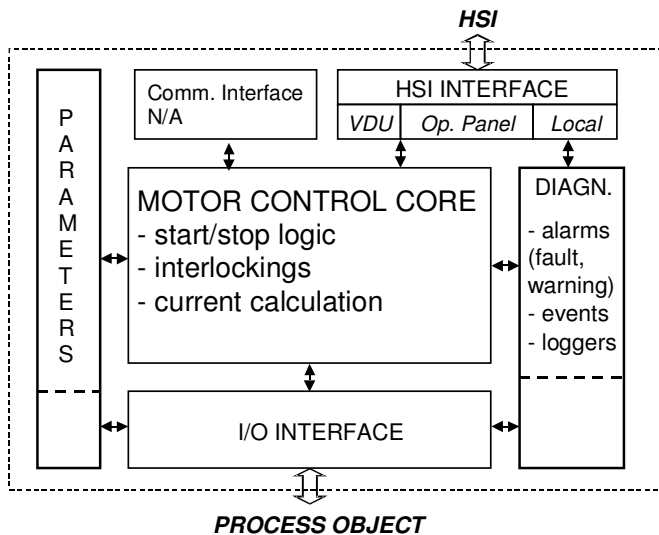

Figure 2-1. The Structure of the Functional Unit

3 Function Block MOT02

FUNCTION OF INPUT TERMINALS	MOT02		FUNCTION OF OUTPUT TERMINALS
Object name	Name	NoInt	No Interlocks
Object description	Description	NoFwdInt	No Interlocks in Forward direction
Enable object	Enable	NoRevInt	No Interlocks in Reverse direction
Enable control circuit alarm	ME	NoICInt	No Safety Interlocks (IC)
Control voltage	M1	NoFwdIBInt	No Process Interlocks (IB) in Forward direction
Overload	M2	NoRevIBInt	No Process Interlocks (IB) in Reverse direction
Motor breaker	M3	NoFwdIAlnt	No Sequence Interlocks (IA) in Forward direction
Emergency stop	M4	NoRevIAlnt	No Sequence Interlocks (IA) in Reverse direction
Short Circuit	M5	Trip	Trip
Safety Interlock 1	IC1	Blk	Standby
Safety Interlock 2	IC2	RFS	Ready for start
Safety Interlocks	ICs	SO1	Start order forward
Process Interlock 1	IB1	SO1P	Start order forward pulse (during T1 time)
Process Interlock 2	IB2	SO2	Start order reverse
Process Interlock 3	IB3	SO2P	Start order reverse pulse (during T1 time)
Process Interlock 4	IB4	SACK	Start order acknowledgement
Forward Process Interlocks	FwdIBs	StartWarn	Start warning
Reverse Process Interlocks	RevIBs	Run	Running
Sequence Interlock 1	IA1	JogInd	Jog mode
Sequence Interlock 2	IA2	LocalInd	Local mode
Forward Sequence Interlocks	FwdIAs	ManInd	Man mode
Reverse Sequence Interlocks	RevIAs	E1Ind	E1 mode
Start function for direction change	STF	E2Ind	E2 mode
Start order pulse Time	T1	Curr	Actual current (%)
Supervision Time	T2	NormCurr	Normal current (%)
Run interlock delay Time	T3	NoOfStart	Number of start
Direction change delay Time	T4	RunTime	Running time (in minutes)
Start warning time	TWarn	OutPar	Out Parameter
Start forward order in E1 mode	E1Fwd	Opr	Operator order
Start reverse order in E1 mode	E1Rev		
Start forward order in E2 mode	E2Fwd		
Start reverse order in E2 mode	E2Rev		
Stop order in external mode	Stop		
Main contactor acknowledge forward	Ack1		
Main contactor acknowledge reverse	Ack2		
Motor current	MC		
Order mode to Jog	JogEnbl		
Forward Start order in Jog mode	JogFwd		
Reverse Start order in Jog mode	JogRev		
Jog start hold function	JogFunc		
Order mode to Local	LEnbl		
Forward Start order in Local mode	L1		
Reverse Start order in Local mode	L2		
Local Stop order	LStop		
Order mode to Man	SeqMan		
Order mode to E1	SeqE1		
Order mode to E2	SeqE2		
Run Interlock 1	RunInt1		
Run Interlock 2	RunInt2		
Function for Run Interlock 2	RunInt2F		
Block alarm	AlcBlk		
Acknowledge alarm	AlarmAck		
MC alarm configuration	MCAalarm		
In Parameter	InPar		
Event name	EventName		

Figure 3-1. Function Block, Complete symbol

Table 3-1 below illustrates the default properties of each terminal of MOT02 function block.

Name	Data Type	Attributes	Direction	FD Port	Initial value	Description
Name	string	coldretain	in	yes	'Mot02'	Object name
Description	string	coldretain	in	yes	'Descr'	Object description
Enable	bool	coldretain	in	yes	true	Enable object
ME	bool	retain	in	yes	true	Enable control circuit alarm
M1	bool	retain	in	yes	true	Control voltage
M2	bool	retain	in	yes	true	Overload
M3	bool	retain	in	yes	true	Motor breaker
M4	bool	retain	in	yes	true	Emergency stop
M5	bool	retain	in	yes	true	Short Circuit
IC1	bool	retain	in	yes	true	Safety Interlock 1
IC2	bool	retain	in	yes	true	Safety Interlock 2
ICs	ICConn	by_ref	in	yes		Safety Interlocks
IB1	bool	retain	in	yes	true	Process Interlock 1
IB2	bool	retain	in	yes	true	Process Interlock 2
IB3	bool	retain	in	yes	true	Process Interlock 3
IB4	bool	retain	in	yes	true	Process Interlock 4
FwdIBs	IBConn	by_ref	in	yes		Forward Process Interlocks
RevIBs	IBConn	by_ref	in	yes		Reverse Process Interlocks
IA1	bool	retain	in	yes	true	Sequence Interlock 1
IA2	bool	retain	in	yes	true	Sequence Interlock 2
FwdIAs	IACConn	by_ref	in	yes		Forward Sequence Interlocks
RevIAs	IACConn	by_ref	in	yes		Reverse Sequence Interlocks
STF	bool	retain	in	yes		Start function for direction change
T1	time	coldretain	in	yes	2s	Start order pulse Time
T2	time	coldretain	in	yes	4s	Supervision Time
T3	time	coldretain	in	yes	5s	Run interlock delay Time
T4	time	coldretain	in	yes	2s	Direction change delay Time
TWarn	time	coldretain	in	yes	0s	Start warning time
E1Fwd	bool	retain	in	yes		Start forward order in E1 mode
E1Rev	bool	retain	in	yes		Start reverse order in E1 mode
E2Fwd	bool	retain	in	yes		Start forward order in E2 mode
E2Rev	bool	retain	in	yes		Start reverse order in E2 mode
Stop	bool	retain	in	yes	true	Stop order in external mode
Ack1	bool	retain	in	yes		Main contactor acknowledge forward
Ack2	bool	retain	in	yes		Main contactor acknowledge reverse
MC	real	retain	in	yes		Motor current
JogEnbl	bool	retain	in	yes		Order mode to Jog
JogFwd	bool	retain	in	yes		Forward Start order in Jog mode
JogRev	bool	retain	in	yes		Reverse Start order in Jog mode
JogFunc	bool	retain	in	yes		Jog start hold function
LEnbl	bool	retain	in	yes		Order mode to Local
L1	bool	retain	in	yes		Forward Start order in Local mode
L2	bool	retain	in	yes		Reverse Start order in Local mode
LStop	bool	retain	in	yes	true	Local Stop order
SeqMan	bool	retain	in	yes		Order mode to Man
SeqE1	bool	retain	in	yes		Order mode to E1
SeqE2	bool	retain	in	yes		Order mode to E2
RunInt1	bool	retain	in	yes	true	Run Interlock 1
RunInt2	bool	retain	in	yes	true	Run Interlock 2
RunInt2F	bool	retain	in	yes		Function for Run Interlock 2
AlcBlk	bool	retain	in	yes		Block alarm
AlarmAck	bool	retain	in	yes		Acknowledge alarm
MCAAlarm	AlarmPar	by_ref	in	yes		MC alarm configuration
InPar	Mot02_InPar	by_ref	in	yes		In Parameter
EventName	string	coldretain	in	yes	' Mot02_'	Event name
NoInt	bool	retain	out	yes		No Interlocks

Name	Data Type	Attributes	Direction	FD Port	Initial value	Description
NoFwdInt	bool	retain	out	yes		No Interlocks in Forward direction
NoRevInt	bool	retain	out	yes		No Interlocks in Reverse direction
NoICInt	bool	retain	out	yes		No Safety Interlocks (IC)
NoFwdIBInt	bool	retain	out	yes		No Process Interlocks (IB) in Forward direction
NoRevIBInt	bool	retain	out	yes		No Process Interlocks (IB) in Reverse direction
NoFwdIAInt	bool	retain	out	yes		No Sequence Interlocks (IA) in Forward direction
NoRevIAInt	bool	retain	out	yes		No Sequence Interlocks (IA) in Reverse direction
Trip	bool	retain	out	yes		Trip
Blk	bool	retain	out	yes		Standby
RFS	bool	retain	out	yes		Ready for start
SO1	bool	retain	out	yes		Start order forward
SO1P	bool	retain	out	yes		Start order forward pulse (during T1 time)
SO2	bool	retain	out	yes		Start order reverse
SO2P	bool	retain	out	yes		Start order reverse pulse (during T1 time)
SAck	bool	retain	out	yes		Start order acknowledgement
StartWarn	bool	retain	out	yes		Start warning
Run	bool	retain	out	yes		Running
JogInd	bool	retain	out	yes		Jog mode
LocalInd	bool	retain	out	yes		Local mode
ManInd	bool	retain	out	yes		Man mode
E1Ind	bool	retain	out	yes		E1 mode
E2Ind	bool	retain	out	yes		E2 mode
Curr	real	retain	out	yes		Actual current (%)
NormCurr	real	retain	out	yes		Normal current (%)
NoOfStart	dint	coldretain	out	yes		Number of start
RunTime	real	coldretain	out	yes		Running time (in minutes)
OutPar	Mot02_OutPar	by_ref	out	yes		Out Parameter
Opr	Mot02_Opr	by_ref	out	yes		Operator order

Table 3-1 Terminal Properties

4 MOT02 Datatypes

4.1 MOT02_InPar

Name	Data Type	Attributes	Initial value	ISP value	Description
Class	dint	coldretain	500		AE class
Severity	dint	coldretain	1000		AE severity
InitMode	dint	coldretain	5		Init mode (5 = Man ; 7 = E1 ; 8 = E2)
JogBlk	bool	coldretain	false		Block operator order Jog mode
LocalBlk	bool	coldretain	false		Block operator order Local mode
ManBlk	bool	coldretain	false		Block operator order Man mode
E1Blk	bool	coldretain	false		Block operator order E1 mode
E2Blk	bool	coldretain	false		Block operator order E2 mode
StartFwdBlk	bool	coldretain	false		Block operator order Start Forward command
StartRevBlk	bool	coldretain	false		Block operator order Start Reverse command
StopBlk	bool	coldretain	false		Block operator order Stop command
AlcBlkEvBlk	bool	coldretain	true		Block event for AlcBlk
LEnblEvBlk	bool	coldretain	true		Block event for LEnbl
JogEnblEvBlk	bool	coldretain	true		Block event for JogEnbl
SeqManEvBlk	bool	coldretain	true		Block event for SeqMan
SeqE1EvBlk	bool	coldretain	true		Block event for SeqE1
SeqE2EvBlk	bool	coldretain	true		Block event for SeqE2
ExtStartFwdEvBlk	bool	coldretain	true		Block event for ExtStartFwd
ExtStartRevEvBlk	bool	coldretain	true		Block event for ExtStartRev
ExtStopEvBlk	bool	coldretain	true		Block event for ExtStop
IABlockNotExtMode	bool	coldretain	true		IA blocked when not in E1 or E2 mode
IA1	IAnParType1	coldretain			Configuration for IA1
IA2	IAnParType1	coldretain			Configuration for IA2
FwdIAs1	IAnParType1	coldretain			Configuration for FwdIAs.IA1
FwdIAs2	IAnParType1	coldretain			Configuration for FwdIAs.IA2
RevIAs1	IAnParType1	coldretain			Configuration for RevIAs.IA1
RevIAs2	IAnParType1	coldretain			Configuration for RevIAs.IA2
IB1	IBInParType1	coldretain			Configuration for IB1
IB2	IBInParType1	coldretain			Configuration for IB2
IB3	IBInParType1	coldretain			Configuration for IB3
IB4	IBInParType1	coldretain			Configuration for IB4
FwdIBs1	IBInParType1	coldretain			Configuration for FwdIBs.IB1
FwdIBs2	IBInParType1	coldretain			Configuration for FwdIBs.IB2
FwdIBs3	IBInParType1	coldretain			Configuration for FwdIBs.IB3
FwdIBs4	IBInParType1	coldretain			Configuration for FwdIBs.IB4
FwdIBs5	IBInParType1	coldretain			Configuration for FwdIBs.IB5
FwdIBs6	IBInParType1	coldretain			Configuration for FwdIBs.IB6
FwdIBs7	IBInParType1	coldretain			Configuration for FwdIBs.IB7
FwdIBs8	IBInParType1	coldretain			Configuration for FwdIBs.IB8
RevIBs1	IBInParType1	coldretain			Configuration for RevIBs.IB1
RevIBs2	IBInParType1	coldretain			Configuration for RevIBs.IB2
RevIBs3	IBInParType1	coldretain			Configuration for RevIBs.IB3
RevIBs4	IBInParType1	coldretain			Configuration for RevIBs.IB4
RevIBs5	IBInParType1	coldretain			Configuration for RevIBs.IB5
RevIBs6	IBInParType1	coldretain			Configuration for RevIBs.IB6
RevIBs7	IBInParType1	coldretain			Configuration for RevIBs.IB7
RevIBs8	IBInParType1	coldretain			Configuration for RevIBs.IB8
IC1	ICInParType1	coldretain			Configuration for IC1
IC2	ICInParType1	coldretain			Configuration for IC2
ICs1	ICInParType1	coldretain			Configuration for ICs.IC1
ICs2	ICInParType1	coldretain			Configuration for ICs.IC2
RatedCurr	real	coldretain	100.0		Rated current
NormalCurr	real	coldretain	50.0		Normal current
CurrUnit	string	coldretain	'A'		Current unit
ShowCurrent	bool	coldretain	false		Show current presentation

Name	Data Type	Attributes	Initial value	ISP value	Description
AEConfigM1	dint	coldretain	1		AE configuration for M1
AEConfigM2	dint	coldretain	1		AE configuration for M2
AEConfigM3	dint	coldretain	1		AE configuration for M3
AEConfigM4	dint	coldretain	1		AE configuration for M4
AEConfigM5	dint	coldretain	1		AE configuration for M5
AEConfigMCErr	dint	coldretain	1		AE configuration for Main Contactor Error
AEConfigRInt1	dint	coldretain	0		AE configuration for Run Interlock 1
AEConfigRInt2	dint	coldretain	0		AE configuration for Run Interlock 2
EnNoOfStartCounter	bool	coldretain	false		Enable number of start counter
EnRunTimeCounter	bool	coldretain	false		Enable running time counter

4.2 MOT02_OutPar

Name	Data Type	Attributes	Initial value	ISP value	Description
AlarmBlk	bool	retain			Alarm blocked
IntlkBlk	bool	retain			Interlock blocked
IntlkBlkActive	bool	retain			Interlock blocked active
EnOverrideAll	bool	retain			Override All button enabled
Mode	dint	retain			Active mode
NormalMode	bool	retain			Normal mode (Active mode = Init mode)
IA1Ind	bool	retain			IA1 interlocked
IA2Ind	bool	retain			IA2 interlocked
IB1Ind	bool	retain			IB1 interlocked
IB2Ind	bool	retain			IB2 interlocked
IB3Ind	bool	retain			IB3 interlocked
IB4Ind	bool	retain			IB4 interlocked
IC1Ind	bool	retain			IC1 interlocked
IC2Ind	bool	retain			IC2 interlocked
FwdIAs1Ind	bool	retain			FwdIAs.IA1 interlocked
FwdIAs2Ind	bool	retain			FwdIAs.IA2 interlocked
FwdIBs1Ind	bool	retain			FwdIBs.IB1 interlocked
FwdIBs2Ind	bool	retain			FwdIBs.IB2 interlocked
FwdIBs3Ind	bool	retain			FwdIBs.IB3 interlocked
FwdIBs4Ind	bool	retain			FwdIBs.IB4 interlocked
FwdIBs5Ind	bool	retain			FwdIBs.IB5 interlocked
FwdIBs6Ind	bool	retain			FwdIBs.IB6 interlocked
FwdIBs7Ind	bool	retain			FwdIBs.IB7 interlocked
FwdIBs8Ind	bool	retain			FwdIBs.IB8 interlocked
ICs1Ind	bool	retain			ICs.IC1 interlocked
ICs2Ind	bool	retain			ICs.IC2 interlocked
RevIAs1Ind	bool	retain			RevIAs.IA1 interlocked
RevIAs2Ind	bool	retain			RevIAs.IA2 interlocked
RevIBs1Ind	bool	retain			RevIBs.IB1 interlocked
RevIBs2Ind	bool	retain			RevIBs.IB2 interlocked
RevIBs3Ind	bool	retain			RevIBs.IB3 interlocked
RevIBs4Ind	bool	retain			RevIBs.IB4 interlocked
RevIBs5Ind	bool	retain			RevIBs.IB5 interlocked
RevIBs6Ind	bool	retain			RevIBs.IB6 interlocked
RevIBs7Ind	bool	retain			RevIBs.IB7 interlocked
RevIBs8Ind	bool	retain			RevIBs.IB8 interlocked
HCurr	AlarmInd	retain			Alarm Indication for HCurr
M1	AlarmInd	retain			Alarm Indication for M1
M2	AlarmInd	retain			Alarm Indication for M2
M3	AlarmInd	retain			Alarm Indication for M3
M4	AlarmInd	retain			Alarm Indication for M4
M5	AlarmInd	retain			Alarm Indication for M5
MCErr	AlarmInd	retain			Alarm Indication for MCErr
RInt1	AlarmInd	retain			Alarm Indication for RInt1
RInt2	AlarmInd	retain			Alarm Indication for RInt2

Name	Data Type	Attributes	Initial value	ISP value	Description
Dir	bool	retain			Running direction (0 = forward, 1 = reverse)
DirChange	bool	retain			Change of running direction
LastStop	dint	retain			Reason for last stop
StartTime	time	retain			Actual starting time
StopTime	time	retain			Actual stopping time

4.3 MOT02_Opr

Name	Data Type	Attributes	Initial value	ISP value	Description
BlockAlarm	bool	retain			Operator block alarms
Jog	bool	retain			Operator order Jog mode
Local	bool	retain			Operator order Local mode
Man	bool	retain			Operator order Manual mode
E1	bool	retain			Operator order E1 mode
E2	bool	retain			Operator order E2 mode
StartFwd	bool	retain			Operator order Start Forward command
StartRev	bool	retain			Operator order Start Reverse command
Stop	bool	retain			Operator order Stop command
OverrideAll	bool	retain			Operator override all interlocks
IB1Override	bool	retain			Operator override IB1 interlock
IB2Override	bool	retain			Operator override IB2 interlock
IB3Override	bool	retain			Operator override IB3 interlock
IB4Override	bool	retain			Operator override IB4 interlock
FwdIBs1Override	bool	retain			Operator override FwdIBs.IB1 interlock
FwdIBs2Override	bool	retain			Operator override FwdIBs.IB2 interlock
FwdIBs3Override	bool	retain			Operator override FwdIBs.IB3 interlock
FwdIBs4Override	bool	retain			Operator override FwdIBs.IB4 interlock
FwdIBs5Override	bool	retain			Operator override FwdIBs.IB5 interlock
FwdIBs6Override	bool	retain			Operator override FwdIBs.IB6 interlock
FwdIBs7Override	bool	retain			Operator override FwdIBs.IB7 interlock
FwdIBs8Override	bool	retain			Operator override FwdIBs.IB8 interlock
RevIBs1Override	bool	retain			Operator override RevIBs.IB1 interlock
RevIBs2Override	bool	retain			Operator override RevIBs.IB2 interlock
RevIBs3Override	bool	retain			Operator override RevIBs.IB3 interlock
RevIBs4Override	bool	retain			Operator override RevIBs.IB4 interlock
RevIBs5Override	bool	retain			Operator override RevIBs.IB5 interlock
RevIBs6Override	bool	retain			Operator override RevIBs.IB6 interlock
RevIBs7Override	bool	retain			Operator override RevIBs.IB7 interlock
RevIBs8Override	bool	retain			Operator override RevIBs.IB8 interlock
IA1Override	bool	retain			Operator override IA1 interlock
IA2Override	bool	retain			Operator override IA2 interlock
FwdIAs1Override	bool	retain			Operator override FwdIAs.IA1 interlock
FwdIAs2Override	bool	retain			Operator override FwdIAs.IA2 interlock
RevIAs1Override	bool	retain			Operator override RevIAs.IA1 interlock
RevIAs2Override	bool	retain			Operator override RevIAs.IA2 interlock
ResetCounter	bool	retain			Order reset counter

5 Function

5.1 Basic Properties

The MOT02 functional unit is designed for control of motors.

MOT02 units consist of the following basic functions.

- Supervision of control circuits
- Evaluation of interlocks
- Control of on/off
- Supervision of motor current
- Running of tests from the motor site
- Control from the local operator's panel
- Manual/External running
- Supervision of operations via Operate^{IT} Operator Station

5.2 Control Modes

MOT02 is intended for control from Operate^{IT} Operator Station, i.e. from a central control room. However, it is also possible to select other modes of control and thus control MOT02 from other locations.

All the control modes can be selected from the central operator station. The LOCAL control mode may also be selected from the local control station.

The different modes of control are as follows:

- Jog
- Local
- Manual
- External 1
- External 2

By selecting control mode, the operator decides from which location the motor is to be controlled. All control modes may be selected through dialog in Operate^{IT} Operator Station. The LOCAL control mode may also be selected from the local control station through the Function Block input :LEnbl, provided that the current control mode is neither JOG, nor DISABLE.

For the different control modes, MOT02 is controlled as follows. For a summary of the control modes, see Table 4-1.

5.2.1 JOG

The control mode JOG is suitable for testing the motor in the field. The motor is supposed to be controlled from a stop/start station adjacent to the motor. Control from other locations is blocked. When the motor is leaving Jog mode a stop order is generated automatically.

The supervision of interlocks is limited. Only the safety interlocks :IC1 and :IC2 as well as faults in the control voltage chain (the inputs :M1 - :M5) prevent starting.

The motor is started and stopped through the inputs :JogFwd, :JogRev and :JogFunc.

:JogFwd, :JogRev, Start order from field-mounted start/stop station

:JogFunc, Stop/Hold function from field-mounted start/stop station

The function of these inputs is set out in tabular form below.

:JogFwd/JogRev	:JogFunc	
0	0	Stop order.
0	1	No change.
1	0	Start and stop order in :JogFwd/JogRev input.
1	1	Start order on :JogFwd/JogRev and stop order on :JogFunc.

When :JogFunc=1, the motor is stopped by breaking the control voltage chain, i.e. signified by any of the :M1 - :M5 inputs going low.

5.2.2 LOCAL

The motor is controlled from a local desk or panel. Control from other locations is blocked.

LOCAL control mode, like other points of control, may be selected from Operate^{IT} Operator Station. In addition, LOCAL control mode may be selected from the local control panel through the input :LEnbl as follows:

:LEnbl = 1: The control mode is LOCAL, as long as the Operate^{IT} Operator Station operator does not request JOG or STAND BY. All other control modes are blocked and :LEnbl must be released before a mode change can occur.

LEnbl -> 0: MOT02 resumes the previous or the latest control mode called for from Operate^{IT} Operator Station.

The operator controls the motor through the inputs :L1, :L2 and :LStop.

:LStop Local stop order (active low)

:L1 Local start order forward

:L2 Local start order reverse

The function of these inputs is set out in tabular form below.

:L1/L2	:Lstart	
0	X	Stop order. Note In order for the motor to start when LStop has been low, LStop must be set high and L1 or L2 must make a low-to-high transition
1	0	No change
1	1	Start order

5.2.3 MANUAL

The motor is controlled from Operate^{IT} Operator Station. Control from other locations is blocked. This is the default control mode. To start, the operator has to press the key FWD or REV. To stop the motor, the key STOP has to be pressed.

5.2.4 EXTERNAL 1 and EXTERNAL 2

The motor is controlled from external signals, e.g. from a process signal. Control from other locations is blocked. This mode is e.g. used for on/off control of levels and for automatic start up and shutdown of belt conveyors etc.

EXTERNAL 2 functions in exactly the same way as EXTERNAL 1. EXTERNAL 2 is used when the motor is to be controlled by Level 2 application software e.g. Auto Series Software.

The function is enabled by inputs :SeqE1 and :SeqE2.

The process controls the motor through the inputs :E1Fwd, :E1Rev, :E2Fwd, :E2Rev and :Stop. The operator is able to stop the motor by issuing stop order from Operate^{IT} Operator Station. The control mode then changes to Manual, to prevent the motor from being restarted.

:Stop Stop order (active low)
:E1(2)Fwd Start order forward
:E1(2)Rev Start order reverse

The function of these inputs is set out in tabular form below:

:Stop	:E1(2)Fwd/Rev	
0	X	Stop order
1	0 -> 1	Start order

:E1(2)Fwd/Rev are dynamic inputs, i.e. they trigger on the rising edge.

5.2.5 DISABLED

The motor is stopped and all orders to it are blocked. Used to take the motor Out of Service.

5.3 Ready for Start

Ready for start means that all the interlocks are satisfied, that there are no alarms and that the control mode is not JOG or that the control is DISABLED.

Ready for start is indicated by the MOT02 displays in the Operate^{IT} Operator Station and by the output terminal :RFS (Ready For Start) in the function block.

5.4 Start-up

An initialisation phase begins at start of the AC800M system.

The result of this becomes:

The outputs are reset (to zero) except for the ManInd terminal, which is set (to 1).

Manual is the default control mode at system initialisation. With an additional circuit it is possible to force the control mode to other modes at system initialisation.

5.5 Interlocks

The motor control can be interlocked by signals from the process and also by signals from the control logic. The interlocks are divided into four groups with the following designations and functions.

Safety Interlocks, which interlock the object for safety purposes. The two safety interlocks, :IC1 and :IC2, cannot be blocked.

Process Interlocks. There are 4 normal process interlocks, :IB1 to :IB4. All four interlocks can be configured to accept blocking by the operator. All four interlocks can also be configured as start interlocks. A start interlock will prevent the motor from starting, but does not stop a running motor.

External (Sequence) Interlocks. Interlocks on terminals :IA1 and :IA2 are used if the object is to be interlocked against other objects such as a pump motor or a group start or other conditions in an automatic sequence. These interlocks are configurable as blocked or not when not in E1 resp. E2 mode.

If *IA blocked when not Ext* is equal to 1

Motor interlocked if IA1 is 0 and the motor is in E1 mode

Motor interlocked if IA2 is 0 and the motor is in E2 mode

If *IA blocked when not Ext* is equal to 0

Motor interlocked if IA1 or IA2 is 0 and the motor is in Man, E1, E2 or Local mode

The interlocks are not included in the conditions for indication of Ready for start.

Run Interlocks. The inputs :RunInt1 and :RunInt2 are intended for connection to operation monitors to obtain tripping or alarm in the event of faults. The inputs are to be TRUE when the equipment is faultless. In order to allow the motor to reach operational speed, RunInt1 and RunInt2 are blocked during the time :T3 after start-up. When the JOG control mode is selected, RunInt1 and RunInt2 are blocked. When RunInt1 or RunInt2 goes to 0, MOT02 remembers this error status until the alarm is acknowledged. :RunInt1 has a motor tripping function whereas the :RunInt2 function can be controlled with the parameter :RunInt2F. When input :RunInt2F = TRUE, the motor is tripped. With :RunInt2F = FALSE, only an alarm is given. Alarm handling of RunInt1 and RunInt2 is blocked internally in the Function Block with the motor at standstill.

An interlocking is active when the input is 0 (FALSE). All Process and external interlocks are blocked when the JOG control mode is selected.

5.6 Start and Stop

Start and stop commands for MOT02 may originate from dialog with Operate^{IT} Operator Station or from Function Block inputs, depending on the control mode selected (See Section 5.2, and Table 3.1).

When a start command is issued to MOT02, it is first checked if a startwarning should be given. A startwarning is given at terminal :StartWarn if the time :TWarn (Startwarning time) is greater than zero. After the time :TWarn has expired the startorder is forwarded to the motor through the Function Block output :SO1 (Start order 1, Forwards/ High) or :SO2 (Start order 2, Reverse/ Low). See Section 5.6.2 Start Order Selection. The start order on the output :SO1P / SO2P is a pulse with a duration which is determined by the input :T1.

The main contactor of the motor acknowledges the start order :SO1 or :SO2 by setting the input :ACK1 resp. :ACK2 high. The main contactor must acknowledge within the time determined by the input :T2.

If the main contactor acknowledges the start order pulse :SO1 or :SO2 within the time T2, MOT02 sets the start order output :SO1 or :SO2 high and keeps it high. The time T3 after the main contactor having responded, MOT02 starts supervising the motor current. The time T3 is determined by the input :T3

If the main contactor does not acknowledge the start order within the time T2, the start attempt is deemed abortive. Consequently, MOT02 issues an alarm about the contactor failure and a new attempt at starting may be made.

The contactor failure alarm indication on the object display of MOT02 disappears when the operator acknowledges the alarm.

MOT02 also issues an alarm about main contactor failure when the contactor acknowledges start orders falsely, i.e. when it sets the inputs :ACK1 or :ACK2 high without any start order being issued. MOT02 transmits the alarm the time T2 after the input having been set.

Input :STF is defining the operators possibility to change startorder when the motor is running. If :STF = 0, the operator must first issue a stop-order before changing direction.

5.6.1 Start and Stop Order at Different Motor Control Modes

The table below describes the commands which can be given at the different control modes of MOT02.

Table 3-1. Relation between commands and control modes

Order	Jog	Local	Manual	Ext1	Ext2
Input JogFwd/JogRev	Start Stop	-	-	-	-
Input L1/L2	-	Start	-	-	-
Input Lstop	-	Stop	-	-	-
Operator start Fwd/Rev	-	-	Start	-	-
Operator stop	-	-	Stop	Stop	Stop
Input E1Fwd/Rev	-	-	-	Start	-
Input E2Fwd/Rev	-	-	-	-	Start
Stop	-	-	-	Stop	Stop

5.6.2 Start Order Selection

The Function Block MOT02 has two start order outputs.

	ABB AB	Doc. no.	Lang.	Rev. ind.	Page
		3AST 001 587D001	en	J	15

:SO1 Start order 1, Forwards/High

:SO2 Start order 2, Reverse/Low

The activation of the outputs is determined as follows from the different points of control.

5.6.2.1 Control mode JOG

FB input :JogFwd or :JogRev

5.6.2.2 Control mode LOCAL

FB input :L1 or :L2

5.6.2.3 Control mode MAN

The operator issues a Start order from Operate^{IT} Operator Station.

5.6.2.4 Control mode Ext1/Ext2

A superior control program sets the inputs :E1(2)Fwd or :E1(2)Rev to issue a new start order.

See the table below.

:E1(2)Fwd/Rev	Stop	Descr
0	0	No change.
1	0	No change.
1	1	Start order

5.6.2.5 Change of Direction/Speed

If a new start-order is issued, this is compared with the previous start-order. If they are different the new order is delayed with time equal to input :T4. For the operator to change speed without first stopping the motor, input :STF must be set to 1 (one).

5.6.2.6 Control mode DISABLE

The motor cannot be started.

5.6.3 Operator Order and Order Blocking

The different orders given by the operator can be read at the output terminal :OprOrder.

Blocking of operator order also possible from the control program by setting the corresponding bits in the terminal :OrdBlk.

5.7 Fault Evaluation in the Control Circuit

Evaluation is performed in the priority order M1, M2, M5, M3 and M4. This means that if the Input :M1 =0, the inputs :M2 - :M5 are not regarded etc. The signal ME interlocks the complete evaluation. ME=0 is used to prevent incorrect alarms with, for example, a total control voltage failure. The inputs M1 to M5 are to be TRUE when there are no errors.

The evaluation presupposes that the control circuit consists of a number of breaking contacts in series.

No alarm will be generated if the motor is not running. The presentation elements will show the faulty state.

5.8 Supervision of Motor Current

The input MC is connected to the process signal for motor current. In the FB element MOT02, the value that corresponds to 100 % load (rated current) is given for the variable NomCurr. The motor current is compared with NomCurr and an alarm indication is obtained if the current is greater than 100 %. During start up, the comparison is blocked during the time T3. The value presented in the Faceplate and Object display in the Operate^{IT} Operator Station is given as a percentage of the rated current (rated current = 100 %).

5.9 Interaction Window

The interaction window is available in the Control^{IT} Control Builder. The interaction window is an engineering aid used to simplify configuration and blocking of signals not available on the faceplates. Changes to values in the Interaction window are only available in 'Online' mode in Control^{IT}.

5.9.1 MOT02 Interaction Window

Interaction window overview. Name and description are shown. The buttons are links to sub-windows.

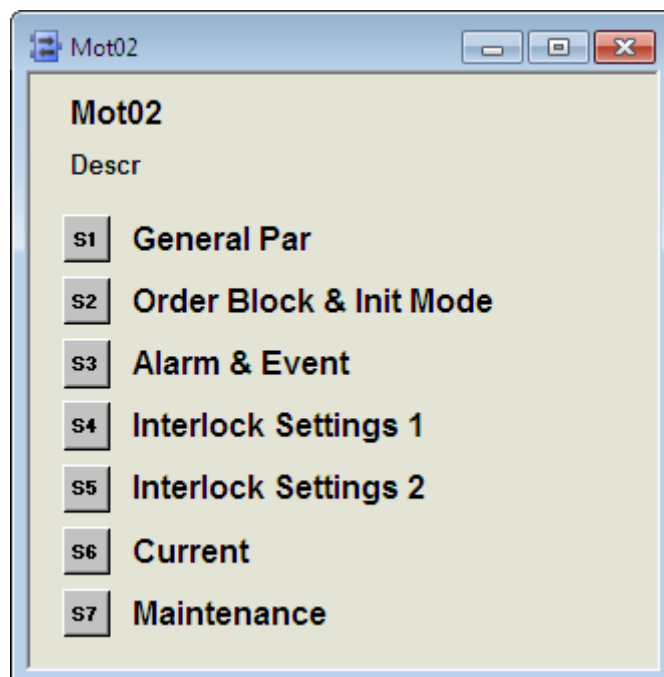

Figure 4-1 Main Interaction Window.

5.9.2 General Parameters

“Class” defines the process section or area in which alarms are grouped. By utilizing class the alarms can be filtered. Valid values are user defined. A suggestion would be to use mill area numbers as class values.

“Severity defines the alarm priority for general alarms. The severity for alarms is entered in window “Alarm & Event”. Valid values are 1 –1000 where 1000 is the highest priority.

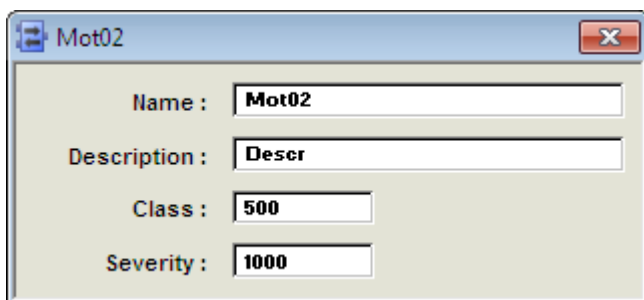

Figure 4-2 General Parameters.

5.9.3 Order Block

Blocking of operator order are entered in this window.

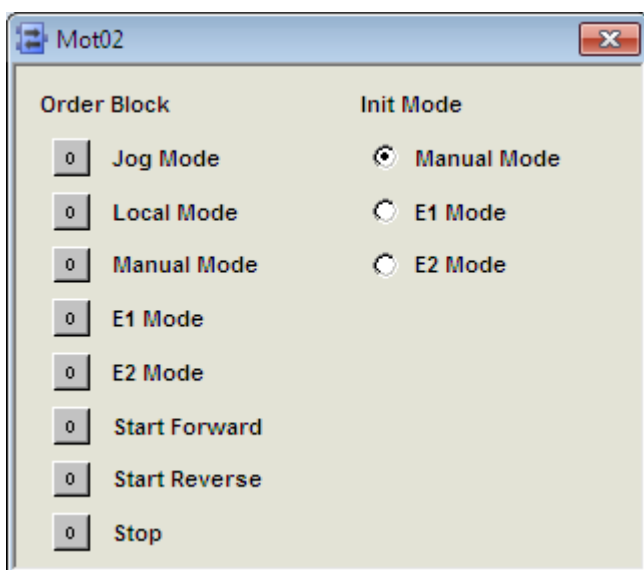

Figure 4-3 Order Block.

5.9.4 Blocking of Alarm and Events

Alarm and Events are generated for status change on the signals defined in interaction window.

All Operator Events are reported by Audit Trail Functionality and not included in the FunctionBlock.

The individual text string for each event is stored in the Alarm and Event Translator aspect. This text can be NLS handled.

For AE config the following values are valid

- 0 No Alarm or Event are generated
- 1 Alarm and Event are generated
- 2 Event is generated



Alarm & Figure 4-4 Indication Event Block.

5.9.5 Interlock Settings

The different settings for interlocks are entered in this window.

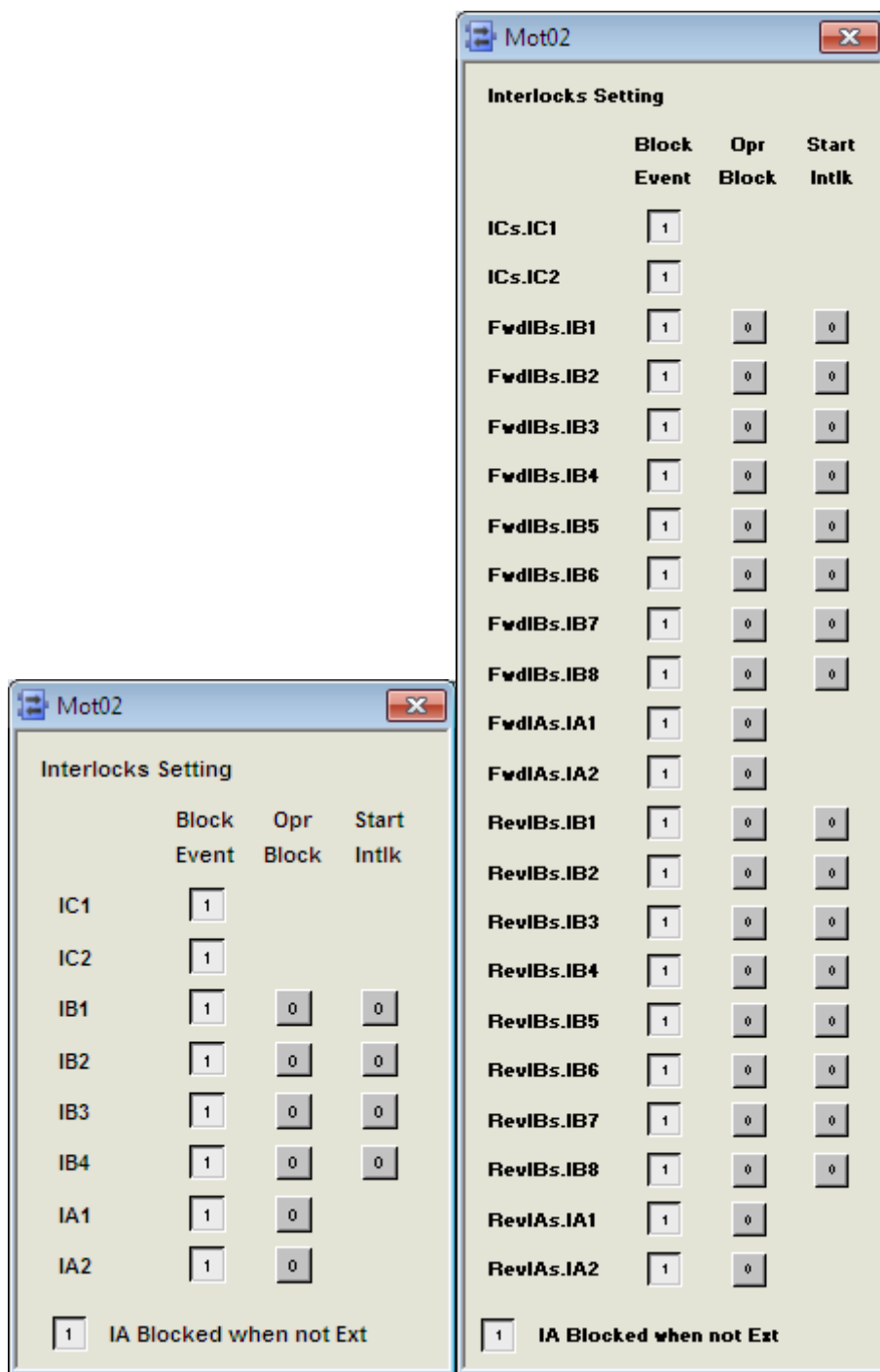

Figure 4-5 Interlock Settings.

5.9.6 Current settings

Motor nominal (rated) current and normal current is entered in this window.

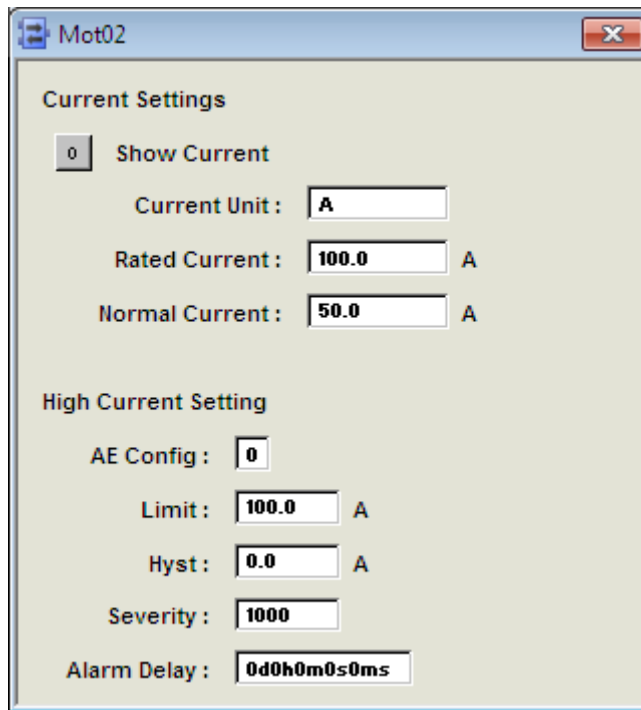

Figure 4-6 Current settings.

5.9.7 Texts

The different interlock and information texts are entered in the aspect Text Properties. The length of the text is limited to about 60 characters, by the size of presentation element in the Interlock Display.

Name	Value	Type	Description	Readable?	R/Permission	Writable?	W/Permission	Deploy Schem
M1Text	Control Voltage	String	M1 Text	Yes		Yes	Configure	Always Repla
M2Text	Overload	String	M2 Text	Yes		Yes	Configure	Always Repla
M3Text	Motor Breaker	String	M3 Text	Yes		Yes	Configure	Always Repla
M4Text	Emergency Stop	String	M4 Text	Yes		Yes	Configure	Always Repla
M5Text	Short Circuit	String	M5 Text	Yes		Yes	Configure	Always Repla
IC1Text		String	IC1 Interlock Text	Yes		Yes	Configure	Always Repla
IC2Text		String	IC2 Interlock Text	Yes		Yes	Configure	Always Repla
ICs								
IC1Text		String	ICs.IC1 Interlock Te	Yes		Yes	Configure	Always Repla
IC2Text		String	ICs.IC2 Interlock Te	Yes		Yes	Configure	Always Repla
IB1Text		String	IB1 Interlock Text	Yes		Yes	Configure	Always Repla
IB2Text		String	IB2 Interlock Text	Yes		Yes	Configure	Always Repla
IB3Text		String	IB3 Interlock Text	Yes		Yes	Configure	Always Repla
IB4Text		String	IB4 Interlock Text	Yes		Yes	Configure	Always Repla
FwdIBs								
IB1Text		String	FwdIBs.IB1 Interloc	Yes		Yes	Configure	Always Repla
IB2Text		String	FwdIBs.IB2 Interloc	Yes		Yes	Configure	Always Repla
IB3Text		String	FwdIBs.IB3 Interloc	Yes		Yes	Configure	Always Repla
IB4Text		String	FwdIBs.IB4 Interloc	Yes		Yes	Configure	Always Repla
IB5Text		String	FwdIBs.IB5 Interloc	Yes		Yes	Configure	Always Repla
IB6Text		String	FwdIBs.IB6 Interloc	Yes		Yes	Configure	Always Repla
IB7Text		String	FwdIBs.IB7 Interloc	Yes		Yes	Configure	Always Repla
IB8Text		String	FwdIBs.IB8 Interloc	Yes		Yes	Configure	Always Repla
RevIBs								
IB1Text		String	RevIBs.IB1 Interloc	Yes		Yes	Configure	Always Repla
IB2Text		String	RevIBs.IB2 Interloc	Yes		Yes	Configure	Always Repla
IB3Text		String	RevIBs.IB3 Interloc	Yes		Yes	Configure	Always Repla
IB4Text		String	RevIBs.IB4 Interloc	Yes		Yes	Configure	Always Repla
IB5Text		String	RevIBs.IB5 Interloc	Yes		Yes	Configure	Always Repla
IB6Text		String	RevIBs.IB6 Interloc	Yes		Yes	Configure	Always Repla
IB7Text		String	RevIBs.IB7 Interloc	Yes		Yes	Configure	Always Repla
IB8Text		String	RevIBs.IB8 Interloc	Yes		Yes	Configure	Always Repla
IA1Text		String	IA1 Interlock Text	Yes		Yes	Configure	Always Repla
IA2Text		String	IA2 Interlock Text	Yes		Yes	Configure	Always Repla
FwdIAs								
IA1Text		String	FwdIAs.IA1 Interlo	Yes		Yes	Configure	Always Repla
IA2Text		String	FwdIAs.IA2 Interlo	Yes		Yes	Configure	Always Repla
RevIAs								
IA1Text		String	RevIAs.IA1 Interloc	Yes		Yes	Configure	Always Repla
IA2Text		String	RevIAs.IA2 Interloc	Yes		Yes	Configure	Always Repla

Figure 4-7 Texts.

5.9.8 Maintenance

The maintenance window shown the reason for the latest stop of the motor. This window also have indication and control of start- and run time-counter.

Mot02

Maintenance

Enable No of Start counter : 0

No of starts:

Enable Run Time counter : 0

Run Time : mins

Reset Counters : 0

Figure 4-9 Maintenance.

6 Operator Functions

The Operator functions are divided in principle into 4 parts:

- Presentation (Display elements, Time logged properties)
- Faceplate (Dialog)
- Alarm and Event handling
- Text handling

6.1 Presentation

6.1.1 Display elements

Display elements which can be used for different display types are available for use in the functional unit MOT02.

The display elements show the status and the controls of the process with different degrees of detail and is intended for the following displays:

- Object display
- Process display
- Interlock display

Examples of different display elements which could be used in these displays are given in the following sections.

6.1.1.1 Object display

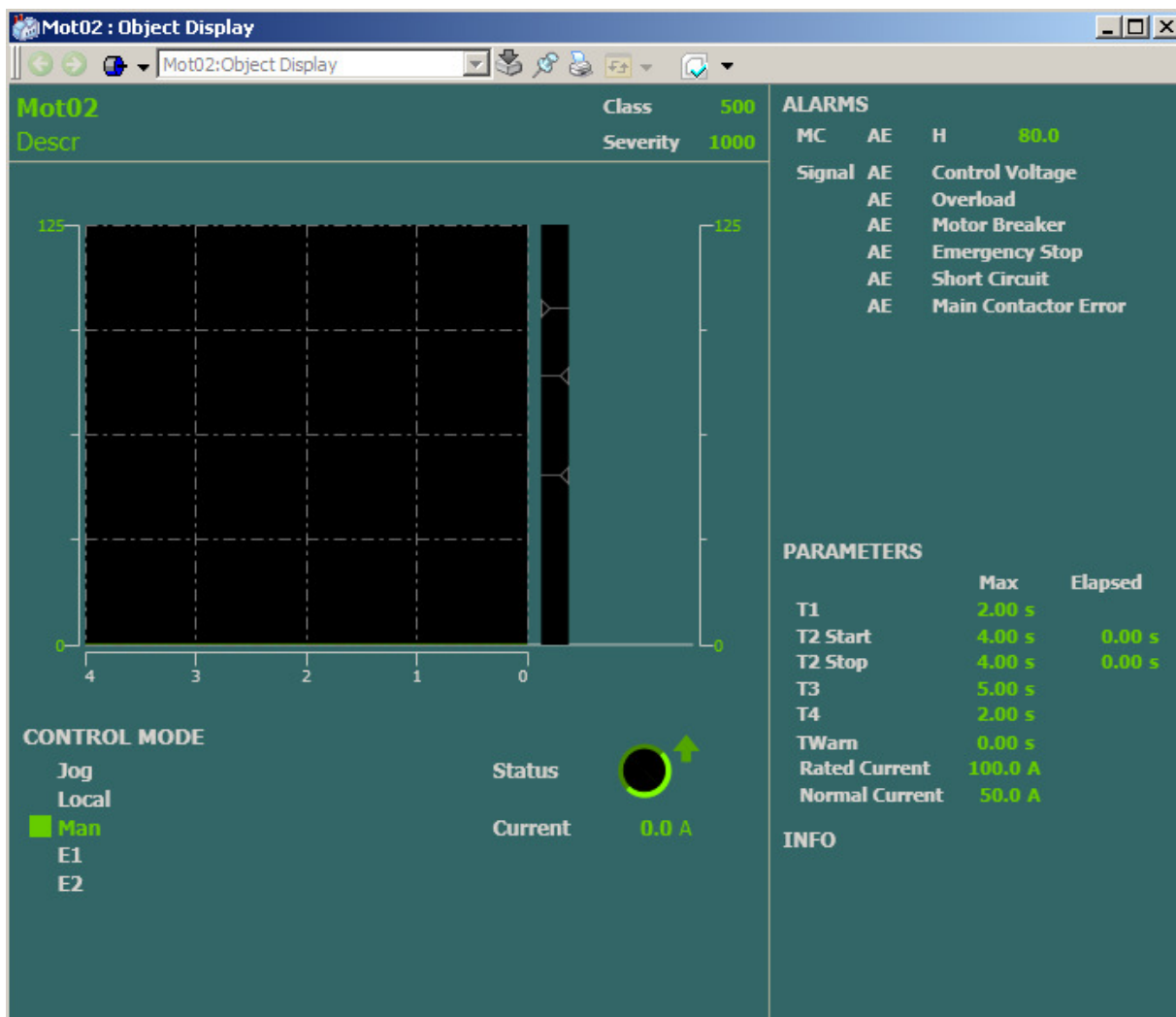

Figure 5-1 Object Display.

6.1.1.2 Process display

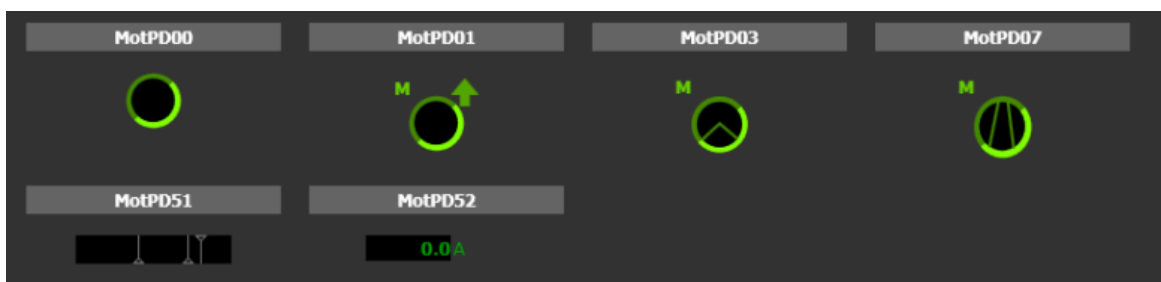

Figure 5-2 Process Display Element.

6.1.1.3 Interlock Display

This display shows the actual status of all Interlock. The operator can override individual interlocks or all interlock.

Interlocks that can be overridden must be set to Blockable. This can be done from this display if the user has permission Configure or from the Interaction Window see chapter 5.9.5

Start Interlock, Block Event and IA Blocked when no in E1 or E2 mode are parameters that can be set from this display if the user has Permission Configure or from Interaction Window.

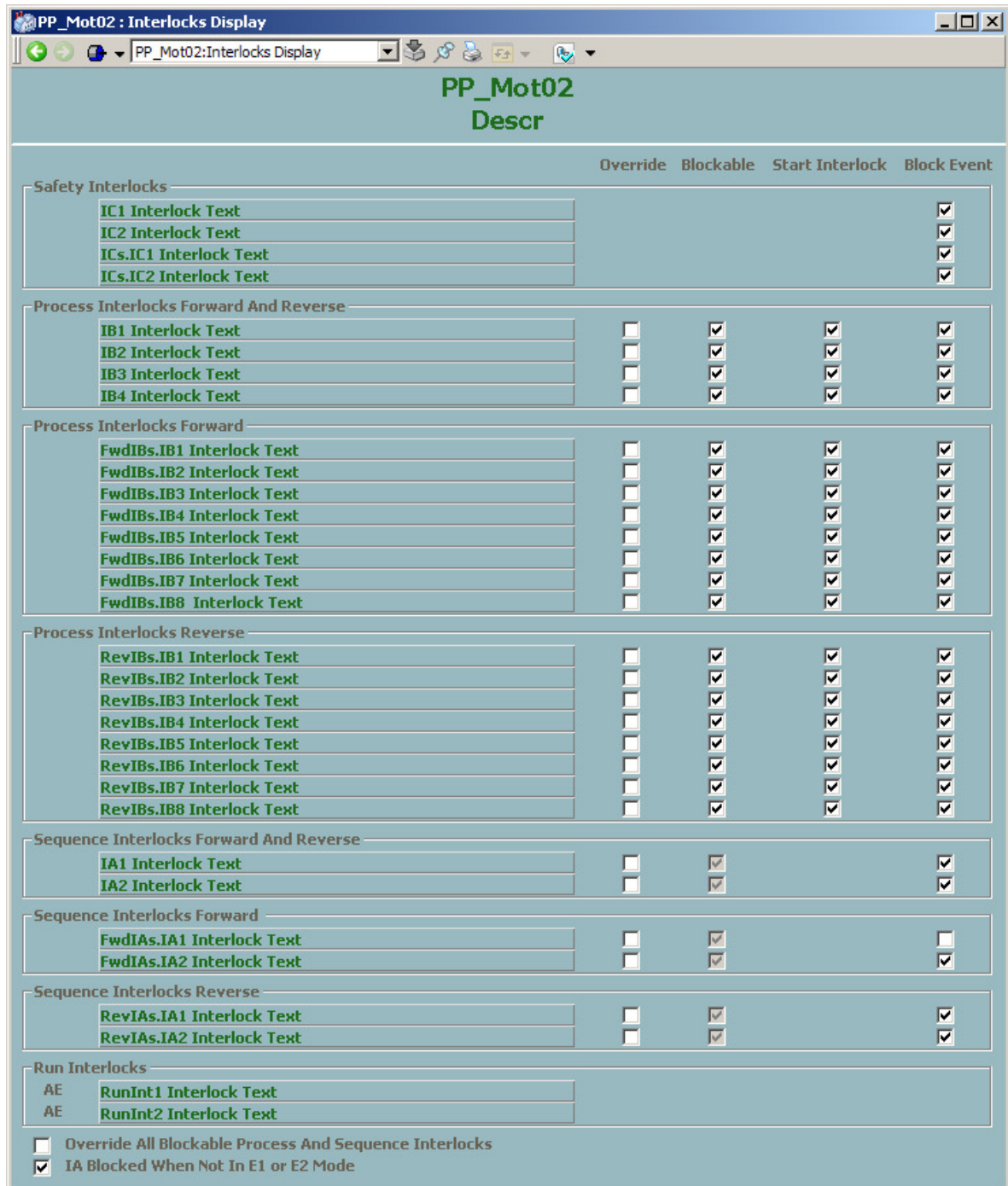

6.1.1.4 Time-logged Properties

Measured values stored can be presented graphically in the form of curves on the display screen. Such a display, a **Trend display**, can consist of 1-4 curves. All properties for the object MOT02 are available to be logged on the trend curves.

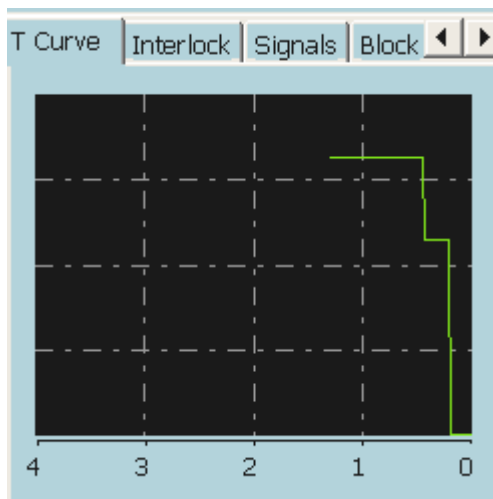
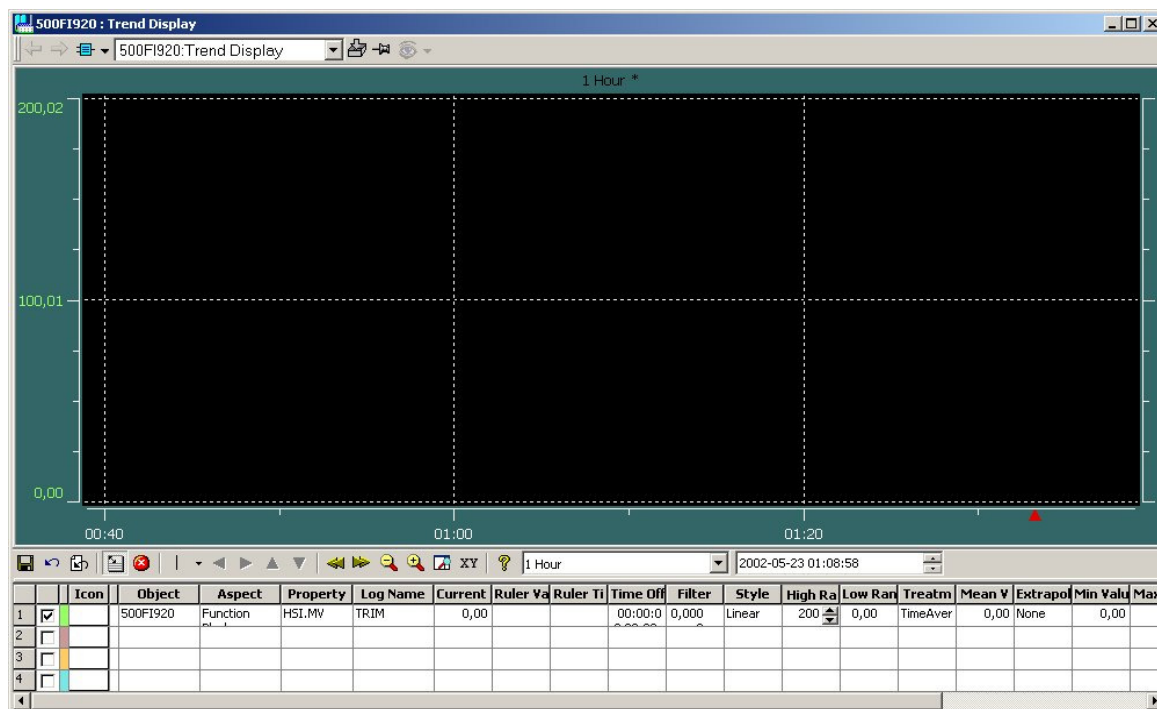

Figure 5-3 Trend Curve

6.2 Faceplate (Dialog)

The display screen is supplemented with a mouse and keyboard for operator communication with the functional unit/object.

By using Operate^{IT} Operator Station the operator can view and control the process through faceplates. The dialogue consists of buttons, indicators and graphic presentations within a Faceplate. A faceplate has three levels of dialogue, which are presented by the following three runtime views:

- Reduced Faceplate, where the size and contents typically have been optimized to cover most of the normal process operator actions. Minimum dialogue.
- Faceplate, which typically covers all normal process operator actions. This view is disabled as default.

- Extended Faceplate, with functions and information intended for the process engineer or the advanced operator. Maximum dialogue.

The figures 5-3 to 5-10 below and overleaf illustrate the various presentations of the faceplate.

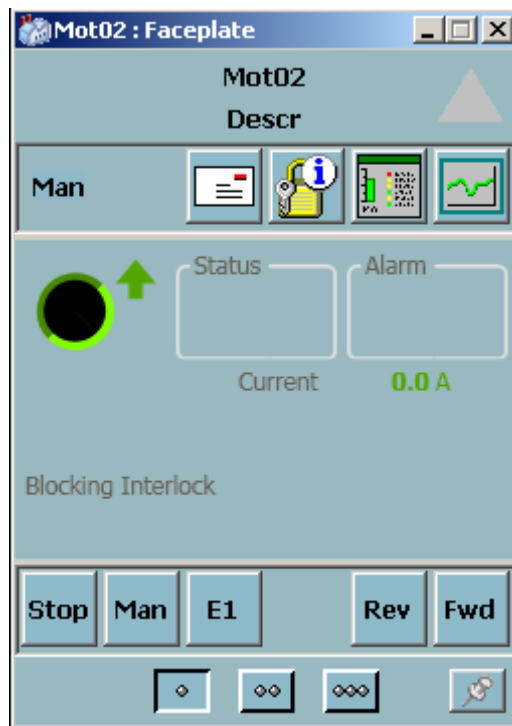

Figure 5-3 Reduced Faceplate

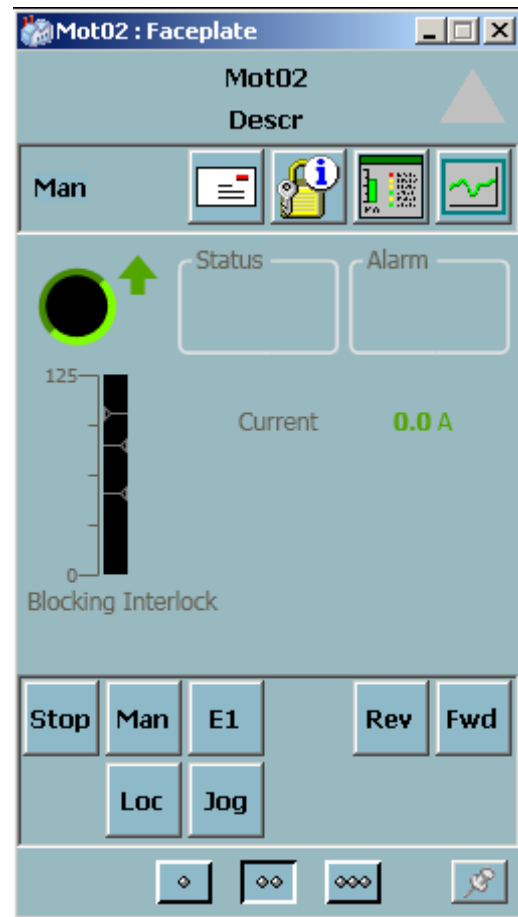

Figure 5-4 Faceplate

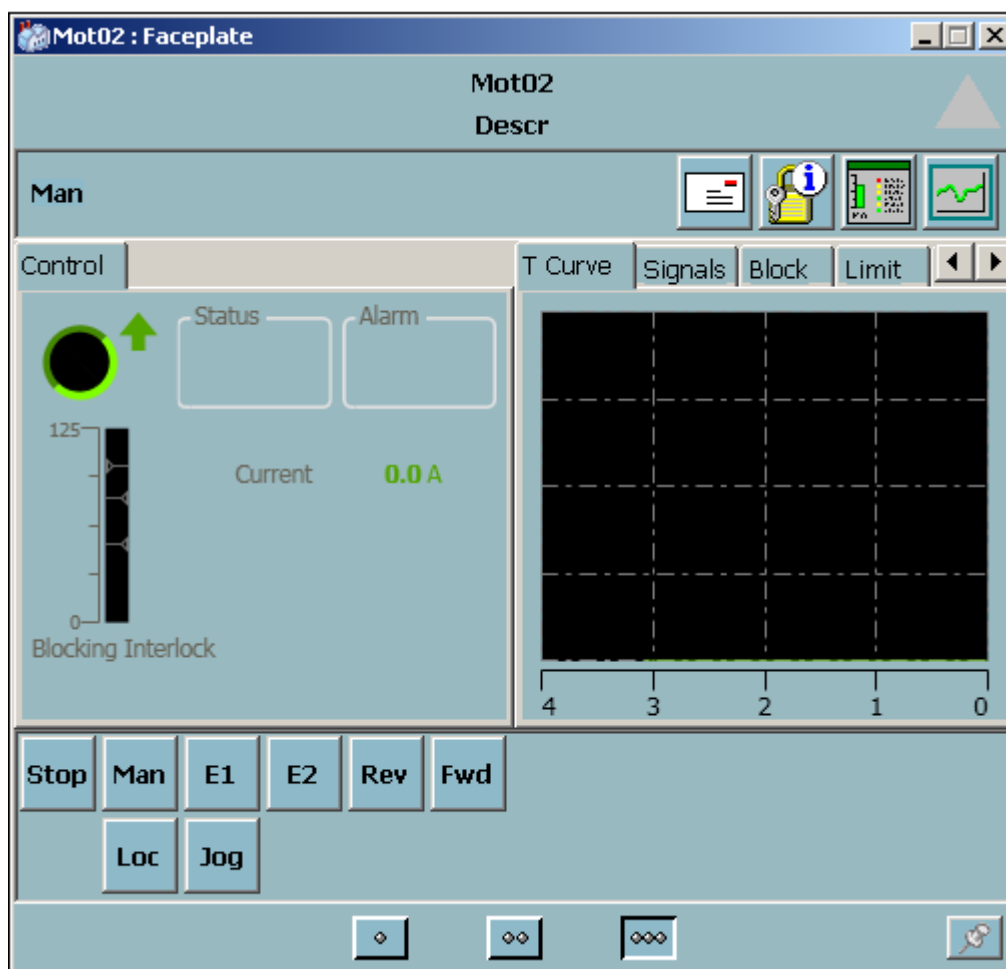

Figure 5-5 Extended Faceplate

6.3 Alarm and Event Handling

6.3.1 General

This section contains a description of all alarms and events in the functional unit MOT02.

When a motor fails an alarm and an event is generated and can be viewed on the Operate^{IT} Operator Station. The alarms are indicated in the faceplate, object display and in the alarm and event list.

The possibilities of the operator to block alarms are shown under the heading 'Event and alarm blocking' below.

The alarm handling for MOT02 can be controlled individually for the different types of fault, which can develop. For example, it is possible to block the alarms for one or more of the monitoring in the control voltage chain M1 to M5. See section 5.9 describing the Interaction Window.

Note, however that the Function Block itself blocks certain alarms in a number of situations. For example RunInt1 and RunInt2 are blocked with the motor at standstill.

The time stamping of the alarm is done when the function block is executed.

Event Time	Object Name	Object Description	Condition	Message Description
02-05-24 03:46:16:763	264M500.RUN	Pulp Mixer Running	Status	Alarm
02-05-24 01:13:04:785	192.168.0.51-0.11.5		HWError	For info see 'Errors and
02-05-24 00:22:18:784	192.168.0.51-0.11.4		HWError	For info see 'Errors and
02-05-23 23:32:31:458	500FI920	Washing Pulp Flow	AI_Err	Alarm
02-05-23 23:32:31:458	500FI920	Washing Pulp Flow	MV_L1	Alarm
02-05-23 23:32:31:458	500FI920	Washing Pulp Flow	MV_L2	Alarm
02-05-23 23:23:01:784	192.168.0.51-0.11.3		HWError	For info see 'Errors and
02-05-23 20:00:07:762	500FI920	Washing Pulp Flow	MV_L2	Alarm
02-05-23 01:38:52:762	500FI920	Washing Pulp Flow	MV_L1	Alarm
02-05-23 00:18:26:995	500FI920	Washing Pulp Flow	AI_Err	Alarm
02-05-22 00:10:00:709	Mot01	Test Mot01	ControlV	Alarm
02-05-20 17:32:45:784	192.168.0.51-0.11.2		HWError	For info see 'Errors and

Figure 5-6 Alarm List

6.3.2 Alarm and Event Message

The following alarm texts are generated by the functional unit Mot02. The “Message Description” are “hard coded” in the function block and can not be modified.

The “Condition” text are stored in the Alarm and Event Translator aspect and can be NLS handled.

Object Name	Object Description	Condition	Message Description
<Name>	<Description>	Control Voltage	Fault
<Name>	<Description>	Emergency Stop	Fault
<Name>	<Description>	Main Contactor	Fault
<Name>	<Description>	High Current	Alarm
<Name>	<Description>	Run Interlock 1	Run1 Text from Interaction Window
<Name>	<Description>	Run Interlock 2	Run1 Text from Interaction Window
<Name>	<Description>	Overload	Fault
<Name>	<Description>	Short Circuit	Fault
<Name>	<Description>	Motor Breaker	Fault

The following Event texts are generated by the functional unit Mot02.

The “Message Description” text are stored in the Alarm and Event Translator aspect and can be NLS handled.

*) Ext Start/Stop is a combination of all Start/Stop orders from Application.

SourceName	ObjectDescription	Condition	Message Description
<Name>	<Description>		SeqE1 Mode
<Name>	<Description>		SeqE2 Mode

<Name>	<Description>		SeqMan Mode
<Name>	<Description>		Local Mode
<Name>	<Description>		Ext Start FWD *)
<Name>	<Description>		Ext Start REV *)
<Name>	<Description>		Ext Stop *)
<Name>	<Description>		IC1 On
<Name>	<Description>		IC1 Off
<Name>	<Description>		IC2 On
<Name>	<Description>		IC2 Off
<Name>	<Description>		IB1 On
<Name>	<Description>		IB1 Off
<Name>	<Description>		IB2 On
<Name>	<Description>		IB2 Off
<Name>	<Description>		IB3 On
<Name>	<Description>		IB3 Off
<Name>	<Description>		IB4 On
<Name>	<Description>		IB4 Off
<Name>	<Description>		IA1 On
<Name>	<Description>		IA1 Off
<Name>	<Description>		IA2 On
<Name>	<Description>		IA2 Off
<Name>	<Description>		Run On
<Name>	<Description>		Run Off
<Name>	<Description>		Alarm Acknowledge
<Name>	<Description>		Alarm Control Block

6.4 Faceplate Tabs

6.4.1 Alarm and Event blocking

By using the faceplate it is possible for the process engineer to block alarms. When the block alarm check box is active then all alarms are blocked as indicated by the yellow "B" in the signals faceplate element.

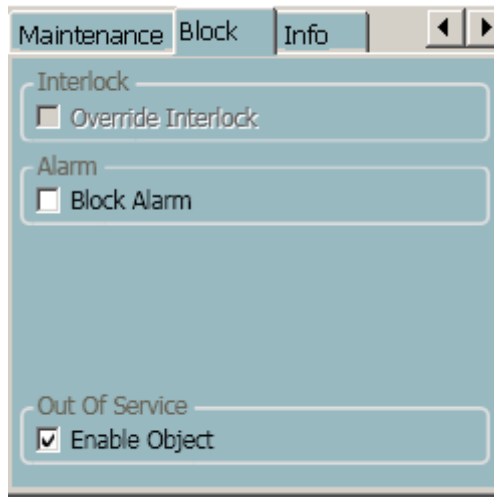

Figure 5-7 Extended Faceplate (Block)

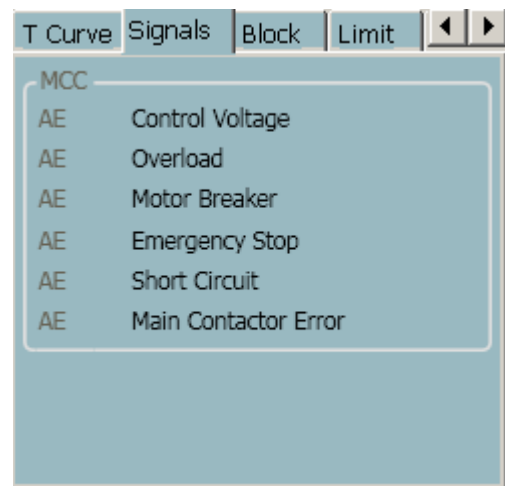

Figure 5-8 Extended Faceplate (Signals)

6.4.2 Limits

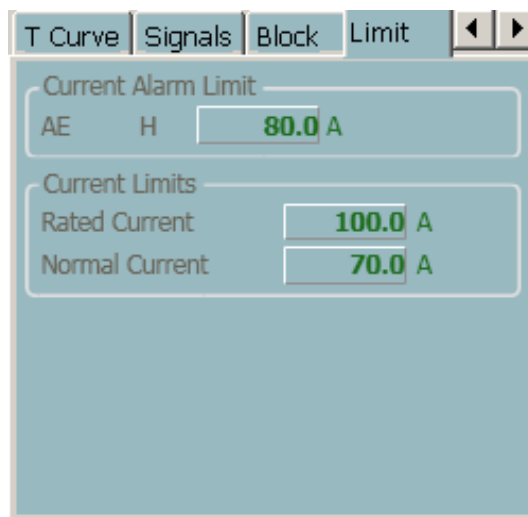

Figure 5-9 Extended Faceplate (Info)

6.4.3 Info tab

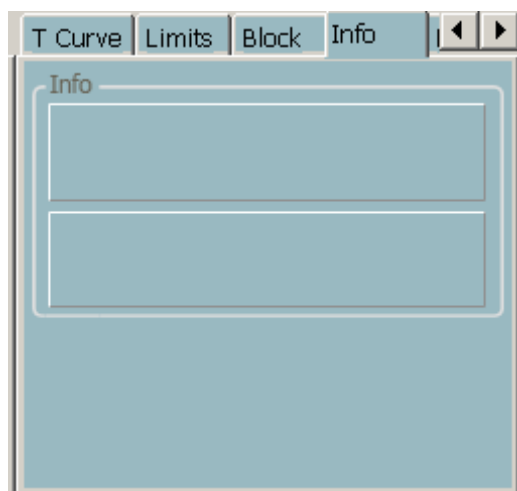

Figure 5-10 Extended Faceplate (Info)

6.4.4 Maintenance

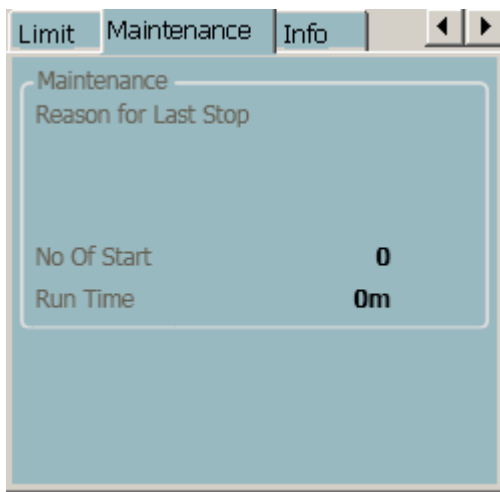

Figure 5-11 Maintenance

REVISION

Rev.	Page (P) Chapt. (C)	Description	Date Dept./Init.
-		First version	
A		Rev 1.3/0	021106/MP
B	5, 7	Initialization	04-04-15/FM
C	3, 4	Rev 3.1/2	050319/MP
D	4,5	Event handling added. Interaction window and faceplate elements are updated	050329/ BP
F	3	Rev 4.0/1	050706/MP
G	3, 4.3.1, 4.8. 5.3.2	Rev 4.0/2	060605/BP
H	4.6	Rev 4.0/5	070510/BP
I		Rev 5.0-1 Interlock functionality is updated	08/11/24/BP
J		Update rev 5.1-0	101103/BP