



Relion® 605 series

REJ603

Self-Powered Feeder Protection

Numerical Feeder Protection without Auxiliary Supply for Secondary Distribution

REJ603 is intended to be used for the selective short-circuit and earth-fault protection of feeders in secondary distribution networks and for protection of transformers in utilities and industries.

REJ603 is a member of ABB's Relion® protection and control product family and its 605 series. The 605 series features basic devices that fulfill the essential protection needs in medium-voltage networks.

Application

REJ603 is a self-powered Numerical relay, which requires no external supply voltage, making it an ideal choice for installation even in remote locations where auxiliary supplies are not available. The relay is primarily used in Ring Main Units within distribution networks and it derives power from the primary current transformers. The relay can measure earth current by internal calculation and also by external core balance current transformer input.

Reliable protection relays for distribution and sub-distribution applications

The protection relay provides 3 phase overcurrent and earth-fault protection functions. Low-set stage has selectable definite time / IDMT characteristics. High-set stage has selectable DMT / Instantaneous element. Integrated protections with selectable curves, wide phase current input range, and extensive internal self-supervision provided in the relay make it a simple and cost-efficient solution for the protection of secondary distribution network.

Selectable characteristics for better co-ordination

The low-set O/C & E/F element of the REJ603 relay has selectable DMT / IDMT characteristics. Apart from 4 standard IDMT characteristics - NI, VI, EI & LTI, relay also has special characteristics like RI, HR & FR fuse, which allows better co-ordination with the entire network. Both low and high-set elements have wide setting ranges. The relay also has short power up time which ensures fast operation during switch on to fault. The IED has been provided with a four-level, role-based user authentication system.

Transformer magnetizing inrush

When applying overcurrent protection to the MV side of the power transformer, it is necessary that the protection system remains inoperative during transformer energization, when a large primary current flows for a short period during switch on. The REJ603 employs the most proven technique of blocking based on measured value of second harmonic content to make the protection immune to magnetizing inrush.

Reliability by Extensive self-supervision

To ensure protection availability and security, extensive self-supervision of the electronics and software is provided in REJ603 relays. The self-supervision system manages run time fault situation and alerts the user to any internal relay faults. The relay has indication LED's for unit Ready and Internal Relay Failure (IRF). Additionally, the relay offers fail safe trip in the combined event of internal relay failure and phase currents exceeding twenty times the maximum nominal current value ($>20 \times I_{smax}$).

External binary input

REJ603 relay is provided with an external binary input, which is activated by an external voltage input. This input can be utilized for remote tripping of circuit breaker while the relay is energised through CTs.

Testing

The special CT's for REJ603 have a test winding to simulate primary current for testing of complete protection scheme including primary CT, relay, and trip coil.

Optional HMI

Advanced functionality like events with time stamp, fault records, display of primary values, fault code which help in post fault analysis are made available with the battery powered HMI. The HMI module, features an innovative touch screen display which facilitates ease of use even with its compact size. In combination with DIP switches, finer settings can be done on the HMI.

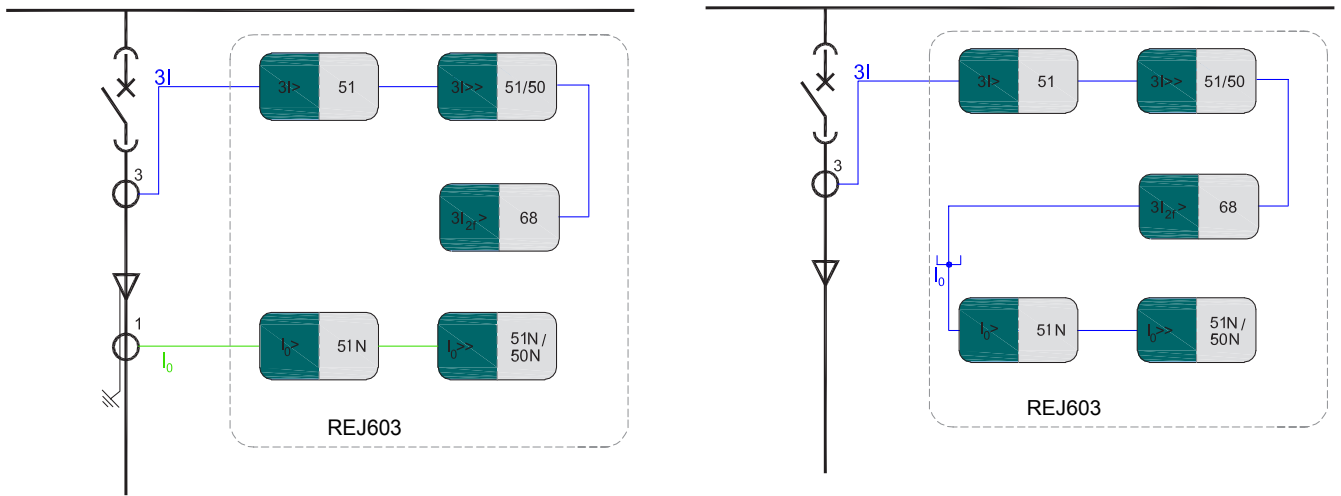

Protection function overview of REJ603.

Supported functions with codes and symbols

Functionality	IEC 60617	ANSI
Protection		
Three phase overcurrent protection, low-set stage	3I>	51
Three phase overcurrent protection, high-set stage	3I>>	50/51
Earth protection, low-set stage	I ₀ >	51N
Earth protection, high-set stage	I ₀ >>	50N/51N
Three phase transformer Inrush detection	3I2f>	68

Current transformers for REJ603

CT type	Rated CT current I _s
REJ603-CT1	8-28 A
REJ603-CT2	16-56 A
REJ603-CT3	32-112 A
REJ603-CT4	64-224 A
REJ603-CT5	128-448 A

Other technical details

Energizing Inputs	
Three phase currents	REJ603 has to be used with specific current transformers (not compatible with conventional 1/5A CT's)
Earth current	Internally by calculation ; Externally by 1A CBCT
Binary inputs	
One binary input (24-240 AC/DC) for remote trip	
Output	
Capacitor discharge impulse (12V dc , 50mJ)	
Trip Indication	
Hand reset electromechanical flag	
Green = OK	
Red = Device has tripped	
Dimensions	
160mm(H) x 96mm(W) x 149mm(D)	
Weight	
~0.8 Kg	

Contact us

For more information see REJ603 Product Guide
or contact us:

ABB Ltd, Distribution Automation

Maneja Works

Vadodara-390013, India

Phone: +91 265 2604386

Fax: +91 265 2638922

www.abb.com/substationautomation