

Arc Protection Module REA 107

Operator's Manual



1. About this manual	5
1.1. Copyrights	5
1.2. Trademarks	5
1.3. Guarantee	5
1.4. General	5
1.5. Use of symbols	6
1.6. Terminology	7
1.7. Abbreviations	7
1.8. Related documents	7
1.9. Document revisions	7
2. Safety	9
3. Introduction	11
3.1. Features	11
3.2. Use of the REA 107 unit	11
4. Block diagram	13
5. Operation	15
5.1. Light detection	15
5.2. Operation of IN and OUT ports	15
5.3. Self-supervision unit	15
5.4. Front panel	16
5.5. Function of LEDs and switches	16
5.5.1. "Light Ref. Level Adj." potentiometer	17
5.5.2. Switchgroup SG1	17
6. Connections	19
7. Commissioning	21
7.1. Setting the unit	21
7.2. Testing the arc protection system	21
7.3. Setting the light reference level	21
8. Dimensions and fixing	23
8.1. REA 107 extension unit	23
8.2. Lens sensors	23
9. Technical data	25

1. About this manual

1.1. Copyrights

The information in this document is subject to change without notice and should not be construed as a commitment by ABB Oy. ABB Oy assumes no responsibility for any errors that may appear in this document.

In no event shall ABB Oy be liable for direct, indirect, special, incidental or consequential damages of any nature or kind arising from the use of this document, nor shall ABB Oy be liable for incidental or consequential damages arising from use of any software or hardware described in this document.

This document and parts thereof must not be reproduced or copied without written permission from ABB Oy, and the contents thereof must not be imparted to a third party nor used for any unauthorized purpose.

The software or hardware described in this document is furnished under a license and may be used, copied, or disclosed only in accordance with the terms of such license.

Copyright © 2005 ABB Oy
All rights reserved.

1.2. Trademarks

ABB is a registered trademark of ABB Group.

All other brand or product names mentioned in this document may be trademarks or registered trademarks of their respective holders.

1.3. Guarantee

Please inquire about the terms of guarantee from your nearest ABB representative.

1.4. General

This manual provides thorough information on the Arc Protection Module REA 107 (later REA 107).

1.5. Use of symbols

This publication includes warning, caution, and information icons that point out safety related conditions or other important information. It also includes tip icons to point out useful information to the reader. The corresponding icons should be interpreted as follows:



The electrical warning icon indicates the presence of a hazard which could result in electrical shock.



The warning icon indicates the presence of a hazard which could result in personal injury.



The caution icon indicates important information or warning related to the concept discussed in the text. It might indicate the presence of a hazard which could result in corruption of software or damage to equipment or property.



The information icon alerts the reader to relevant facts and conditions.



The tip icon indicates advice on, for example, how to design your project or how to use a certain function.

Although warning hazards are related to personal injury, and caution hazards are associated with equipment or property damage, it should be understood that operation of damaged equipment could, under certain operational conditions, result in degraded process performance leading to personal injury or death. Therefore, comply fully with all warning and caution notices.

1.6. Terminology

The following is a list of terms associated with REA 107 that you should be familiar with. The list contains terms that are unique to ABB or have a usage or definition that is different from standard industry usage.

Term	Description
Central unit	Arc Protection Relay REA 101
Extension unit	Arc Protection Module REA 103, REA 105, or REA 107.
IRF relay	A relay with change-over (NO or NC) output contacts. Usually, the NO output gap is used. When no fault is detected in the auxiliary power supply or in the relay, this contact gap is closed.
IRF relay resets	When the self-supervision system of the relay detects a fault in the relay function or in the auxiliary power supply, the contact opens, that is, the IRF relay resets.
Optolink communication	The communication between REA 101 central units.

1.7. Abbreviations

IRF	Internal relay fault
LED	Light-emitting diode
NC	Normally closed
NO	Normally open
SG	Switch group



1.8. Related documents

Name of the manual	MRS number
Arc Protection Relay REA 10_, Buyer's Guide	1MRS 750929-MBG
Arc Protection Relay REA 101, Operator's Manual	1MRS 751003-MUM
Arc Protection Module REA 103, Operator's Manual	1MRS 751004-MUM
Arc Protection Module REA 105, Operator's Manual	1MRS 751005-MUM

1.9. Document revisions

Version	Revision number	Date	History
B	-	09.06.2005	-Updated commissioning instructions and technical data -Updated figures

2.**Safety**

	National and local electrical safety regulations must always be followed.
	Dangerous voltages can occur on the connectors, even though the auxiliary voltage is disconnected.
	The frame of the device has to be carefully earthed.
	Only a competent electrician is allowed to carry out the electrical installation.
	Sensor fibers have to be handled according to the instructions given by the sensor fiber manufacturer.
	Sensor fibers have to be handled with care. Sharp bends must be avoided; the minimum allowed bending radius is 100 mm. To avoid stepping on sensor fibers, they should not be placed on the floor unnecessarily during the installation.
	Settings and configuration changes have to be done with the auxiliary supply voltage (U_{aux}) disconnected. Malfunction may occur if changes are made with the supply voltage connected.

3. Introduction

The Arc Protection Module REA 107 is an extension unit designed to be used together with the central unit, Arc Protection Relay REA 101.

3.1. Features

- 8 lens-type sensors for arc detection
- 2 signal relays
- 2 RJ-45 ports for connecting REA 101 relay and other extension units
- Self-supervision unit that monitors operating voltages
- LED indicators for each sensor

3.2. Use of the REA 107 unit

The function of the REA 107 unit is to detect light and to provide the REA 101 relay with information about this.

The use of the extension unit allows the protection area to be extended and the protected object to be divided into smaller areas.

4. Block diagram

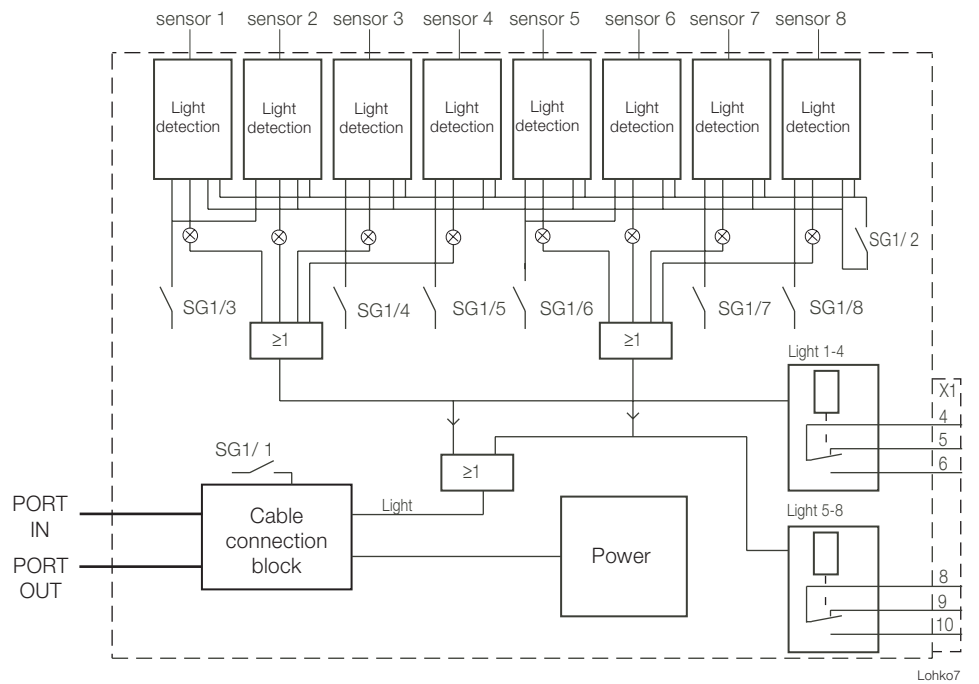

Fig. 4.-1 Block diagram of REA 107

5. Operation

5.1. Light detection

The light is collected by the lens-type sensors, which are connected with plastic fibers to the sensor inputs 1...8. The switches SG1/3...8 are used for selecting sensors 1...8. The light captured by the sensor is amplified and compared either to an automatic or a manual reference level.

When the reference level is exceeded, a signal is generated to the central unit REA 101, the signal relay (Light 1...4 or 5...8) of the concerned sensor group is activated for about 0.5 second, and a corresponding LED is lit. In a trip situation, REA 101 provides information about the tripping, and the relay is locked in the active state. If no tripping occurs, the signal relay is reset.

The SG1/2 switch is used for selecting the automatic or manual reference level. The unit itself forms the automatic reference level according to the present backlight intensity measured by an individual sensor. The "Light Ref. Level Adj." potentiometer (common to all of the sensors) on the front panel is used for selecting the manual reference level.

5.2. Operation of IN and OUT ports

The ports IN and OUT are connected in parallel. The connection cable from the central unit REA 101 is connected to the port IN and the connection cable to the next extension unit departs from the port OUT. A maximum of 5 extension units can be chained to one port in REA 101.

The terminators have to be connected (switch SG1/1) in the last extension unit of the chain. This allows the REA 101 relay to monitor the condition of the connection cable. Should the terminators be unconnected, the fault indication LED "Port A Fault" or "Port B Fault" and the "IRF" LED of the central unit REA 101 are lit, and the IRF relay is reset.



When the REA 10_ units are located in separate switchgears, the connection between the REA 10_ units must be made by using optolink unless it can be ensured that the switchgears are in the same potential in all conditions.



The REA 107 extension unit does not need its own auxiliary voltage supply; it is supplied by the central unit REA 101 over the connection cable.

5.3. Self-supervision unit

The self-supervision system monitors the operating voltages of the device. If a fault is detected in the operating voltages, the self-supervision unit prevents the device from operating. When the "IRF" LED of the REA 107 extension unit is lit, the port fault LED "Port A Fault" or "Port B Fault" of the REA 101 relay starts flashing and the "IRF" LED is lit, and the IRF relay is reset.

5.4. Front panel

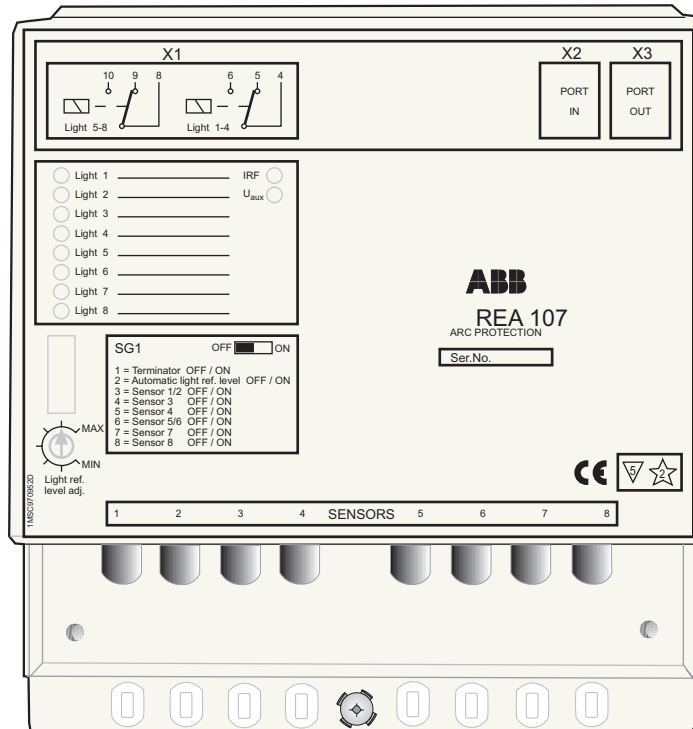

A050329

Fig. 5.4.-1 REA 107 front panel

5.5. Function of LEDs and switches

Table 5.5.-1 REA 107 LEDs

LED	Indication when the LED is lit
U _{aux}	Power supply is connected.
Light 1	The sensor 1 has detected light.
Light 2	The sensor 2 has detected light.
Light 3	The sensor 3 has detected light.
Light 4	The sensor 4 has detected light.
Light 5	The sensor 5 has detected light.
Light 6	The sensor 6 has detected light.
Light 7	The sensor 7 has detected light.
Light 8	The sensor 8 has detected light.
IRF	The self-supervision system has detected a fault. (The fault LED "Port A Fault" or "Port B Fault" of the REA 101 relay is flashing, the IRF LED is lit, and the IRF relay has been reset.)

5.5.1. “Light Ref. Level Adj.” potentiometer

- Potentiometer for manual backlight compensation:
 - Potentiometer is in use, if switch SG1/2 is in OFF position.
 - Potentiometer is not in use, if the switch SG1/2 is in ON position.

5.5.2. Switchgroup SG1

- Switch 1 (terminators):
 - Switch 1 is in ON position:
the terminators are connected.
 - Switch 1 is in OFF position:
the terminators are not connected.
- Switch 2 (automatic light reference level):
 - Switch 2 is in ON position:
automatic backlight compensation is selected
(the “Light Ref. Level Adj.” potentiometer is not in use).
 - Switch 2 is in OFF position:
manual backlight compensation is selected
(the “Light Ref. Level Adj.” potentiometer is in use).
- Switch 3 (sensor 1 and 2)
 - Switch 3 is in ON position:
sensors 1 and 2 are used for arc detection
 - Switch 3 is in OFF position:
sensors 1 and 2 are not in use
- Switch 4 (sensor 3)
 - Switch 4 is in ON position:
sensor 3 is used for arc detection
 - Switch 4 is in OFF position:
sensor 3 is not in use
- Switch 5 (sensor 4)
 - Switch 5 is in ON position:
sensor 4 is used for arc detection
 - Switch 5 is in OFF position:
sensor 4 is not in use
- Switch 6 (sensors 5 and 6)
 - Switch 6 is in ON position:
sensors 5 and 6 are used for arc detection
 - Switch 6 is in OFF position:
sensors 5 and 6 are not in use

Operator's Manual

- Switch 7 (sensor 7)
 - Switch 7 is in ON position:
sensor 7 is used for arc detection
 - Switch 7 is in OFF position:
sensor 7 is not in use
- Switch 8 (sensor 8)
 - Switch 8 is in ON position:
sensor 8 is used for arc detection
 - Switch 8 is in OFF position:
sensor 8 is not in use

6. Connections

Connector X1

1	Not in use	
2	Not in use	
3	Not in use	
4	Light 1...4 common	
5	Light 1...4 /NC	Signal relay of sensors 1...4
6	Light 1...4 /NO	Signal relay of sensors 1...4
7	Not in use	
8	Light 5...8 common	Signal relay of sensors 5...8
9	Light 5...8 /NC	Signal relay of sensors 5...8
10	Light 5...8 /NO	Signal relay of sensors 5...8

Connection ports X2 and X3

X2 Port IN
X3 Port OUT

Sensor 1 connector

Sensor 1

Sensor 2 connector

Sensor 2

Sensor 3 connector

Sensor 3

Sensor 4 connector

Sensor 4

Sensor 5 connector

Sensor 5

Sensor 6 connector

Sensor 6

Sensor 7 connector

Sensor 7

Sensor 8 connector

Sensor 8

7. Commissioning

7.1. Setting the unit



All switch settings have to be made before the auxiliary voltage supply of the unit is connected.

1. Program the switchgroup SG1.

The default setting for the switchgroup SG1 is “00000000”.

2. Set the switches of the switchgroup SG1 as required by the application.

Refer to Section 5.5. Function of LEDs and switches, and to the application examples given in the operator's manual of REA 101. Refer to Section 1.8. Related documents.

3. Set the potentiometer “Light Ref. Level Adj.”.

As a default, the potentiometer is in the middle position. If the automatic backlight compensation has been selected (the switch SG1/2 is in ON position), the setting of the potentiometer does not have to be changed.

7.2. Testing the arc protection system

1. Check the current measurement function of each REA 101 relay by measuring the primary or secondary circuit. When the current threshold is exceeded, the “Current” LED of the REA 101 relay is lit.
2. Turn the “Trip Condition” key switch into “Light” position to check that the overcurrent data is transmitted through the entire system arrangement as required by the application.
3. Check that the “Current” LED of the concerned REA 101 unit is lit.
4. Finally, turn the “Trip Condition” key switch into the “Current&Light” position.
5. Check each REA 101 relay included in the application in the same way.

7.3. Setting the light reference level

1. Set the lighting level of the environment as close to normal work conditions as possible.
2. Turn the “Light Ref. Level Adj.” potentiometer of the REA 107 unit until the “Light” LED is lit, or goes off.
3. Turn the potentiometer one scale mark to the right.



If the “Light” LED stays off even though the potentiometer is in the “Min.” position, you can either leave the potentiometer in this position or turn it one or several scale marks to the right, depending on the wanted sensitivity level.

Operator's Manual

4. Turn the “Trip Condition” key switch of one REA 101 relay into “Light” position.



The Trip Condition key switch must always be in an extreme position.

5. Expose one sensor fiber at a time to light by using, for example, a flash and check that the right circuit breakers operate.



The flash duration should be at least 1 ms. Note that the integrated flashes of pocket cameras are normally not powerful enough. Using separate flash units with fresh batteries (guide nr 20 or more) is recommended.

6. When all the sensor fibers are tested, set the “Trip Condition” key switch of the REA 101 relay(s) as required by the application.

8. Dimensions and fixing

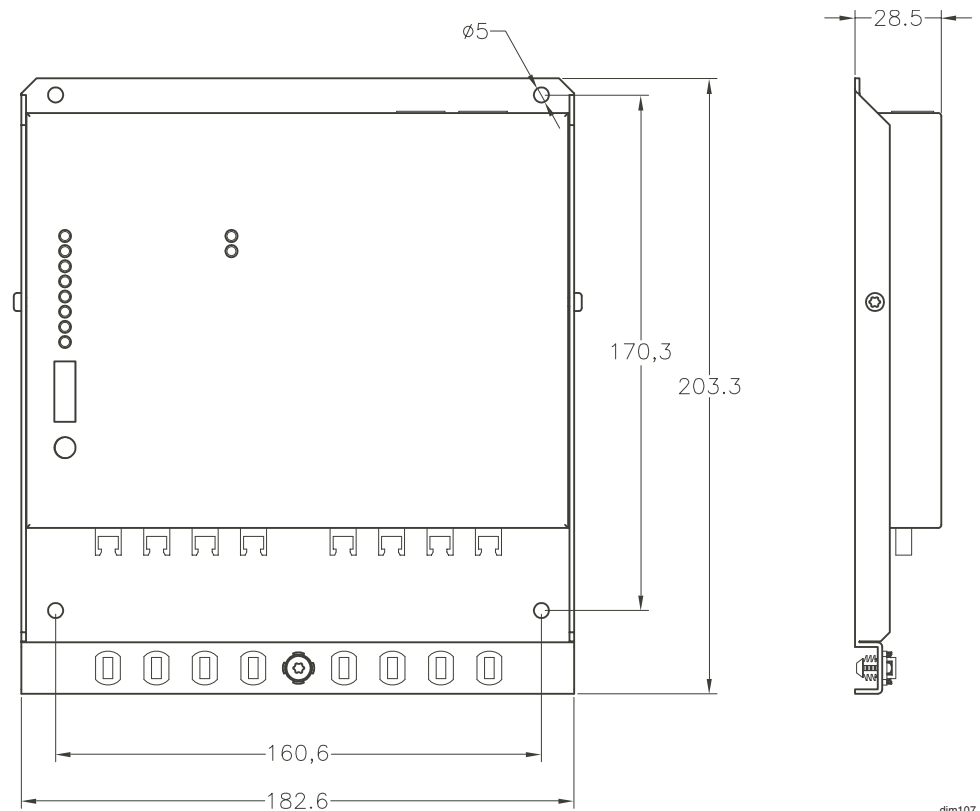

Fig. 8.-1 REA 107 dimensions

8.1. REA 107 extension unit

Fixing method 1: M4 threaded hole, fixing with M4 machine screw.

Fixing method 2: ϕ 4.2 mm hole, fixing with M4 machine screw and nut.

Fixing method 3: Fixing with a self-tapping M4 screw.

8.2. Lens sensors

Fixing method 1:

1. Drill a hole (ϕ 10 mm) in the wall of the supervised space.
2. Put the lens sensor in the hole.
3. Fix the lens sensor with a self-tapping M3 screw.

Fixing method 2:

Fix the lens sensors by using a cable tie.

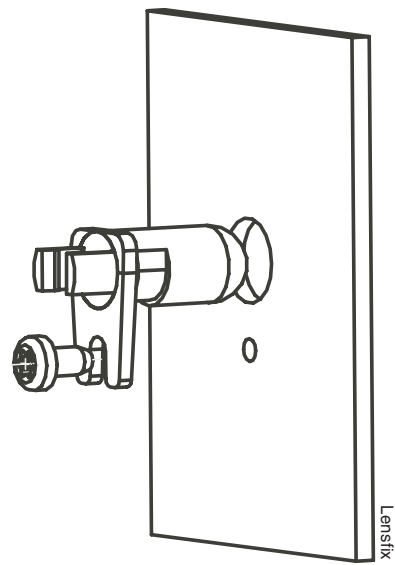

Fig. 8.-2 Fixing of lens sensor

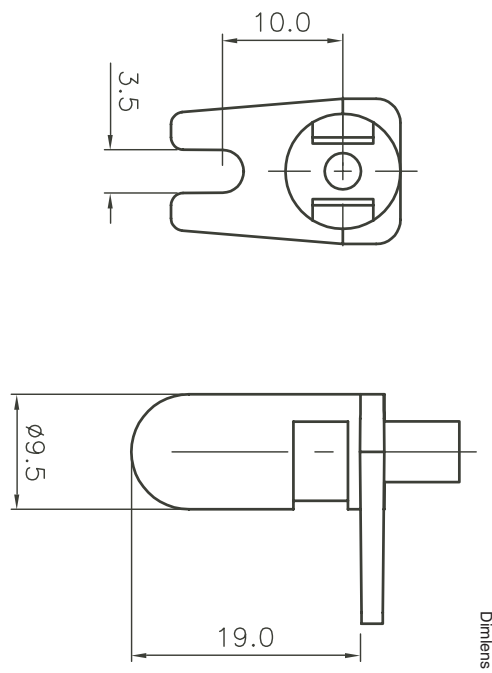

Fig. 8.-3 Dimensions of lens sensor

9. Technical data

Table 9-1 Signal contacts (Light 1...4, Light 5...8)

Rated voltage	250 V DC/AC
Continuous carry	5 A
Make and carry for 0.5 s	10A
Make and carry for 3 s	8A
Breaking capacity for DC, when the control circuit time constant $L/R \leq 40\text{ms}$, at 48/110/220 V DC	1 A/0.25 A/0.15 A

Table 9-2 Power consumption (operating voltage over the REA 101 port^a)

Under quiescent conditions/ maximum	~1.7 W / ~2.7 W
-------------------------------------	-----------------

a. A maximum of 5 extension units can be linked to one REA 101 port.

Table 9-3 Lens sensor

Normal service temperature range	-40...+100 °C
Maximum service temperature (maximum time is 1h)	+140 °C
Minimum permissible bending radius of the connection fiber	100 mm

Table 9-4 Connection cable (central unit - extension unit)

Maximum length ^a	40 m
-----------------------------	------

a. Total length of the connection chain between the central unit and extension units.

Table 9-5 Environmental tests

Specified service temperature range	-10...+55 °C
Transport and storage temperature range	-40...+70 °C
Dry heat test	According to IEC 68000-2-2
Dry cold test	According to IEC 68000-2-1
Damp heat test cyclic	According to IEC 68000-2-30 r.h. >95%, t = 20...55 °C
Storage temperature test	According to IEC 68000-2-48

Table 9-6 Enclosure

Degree of protection, IEC 60529	IP 20
Weight	1.0 kg

Table 9-7 Insulation tests

Dielectric test according to IEC 60255-5	2 kV, 50 Hz, 1 min
Impulse voltage test according to IEC 60255-5	5 kV, 1.2/50 μs , 0.5 J
Insulation resistance test according to IEC 60255-5	> 100 M Ω , 500 V DC

Table 9.-8 Electromagnetic compatibility tests

1 MHz burst disturbance test according to IEC 60255-22-1:	
• Common mode	2.5 kV
• Differential mode	1.0 kV
Electrostatic discharge test according to IEC 61000-4-2 class IV, IEC 60255-22-2 class III, and ANSI/IEEE C37.90.3-2001:	
• Contact discharge	8 kV
• Air discharge	15 kV
Radio-frequency electromagnetic field disturbance test according to IEC 61000-4-3 and IEC 60255-22-3:	
Amplitude-modulated:	
• Frequency f	80...1000 MHz
• Field strength E	10 V/m (rms)
Pulse-modulated:	
• Frequency f	900 MHz
• Field strength E	10 V/m (rms)
Radio frequency disturbance test according to IEC 61000-4-6 and IEC 60255-22-6:	
• Conducted, common mode	10 V, 150 kHz...80 MHz
Fast transient disturbance test according to IEC 60255-22-4 and IEC 61000-4-4:	
	4 kV
Surge immunity test according to IEC 61000-4-5 and IEC60255-22-5:	
Signal output contacts:	
• Line-to-earth	2 kV
• Line-to-line	1 kV
Electromagnetic emission tests:	
• Radiated RF emission	EN 550011, class A, IEC 60255-25
SWC tests according to ANSI/IEEE C37.90.1-2002:	
• Oscillatory tests	2.5 kV
• Fast transient test	4 kV
Power frequency (50 Hz) magnetic field according to IEC61000-4-8	
	300 A/m, continuous

Table 9.-9 Mechanical tests

Vibration tests according to IEC 60255-21-1	class 1
Shock and bump test according to IEC 60255-21-2	class 1
Seismic tests according to IEC 60255-21-3	class 2



ABB Oy

Distribution Automation

P.O. Box 699

FI-65101 Vaasa

FINLAND

Tel. +358 10 22 11

Fax. +358 10 224 1094

www.abb.com/substationautomation