

Product Guide

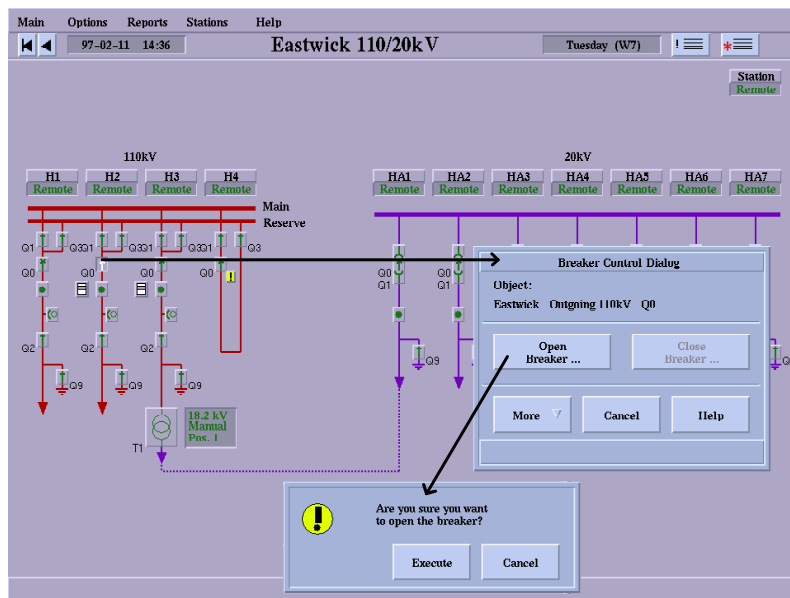

Features

- Application library for MV process applications built using ABB Substation Automation products
- Application library for process applications built with RTU 200 and RTU 210
- Installable process objects for station level functions, bay level functions, switching device functions and for measurement functions
- SPA relay tool for setting parameters and for analyzing recorded data from SPACOM terminals
- RED relay tool for setting parameters and for analyzing recorded data from RE_5___ terminals
- Measurement trend reports presented in curve mode or in table mode
- Programmable measurement reports
- Disturbance recorder uploading from SPACOM terminals

Application

The MV process includes standard functions needed to build single-line process applications. The engineering is divided into two subtasks:

- single-line editing (static picture background editing and standard function installation)
- single-line configuration (standard function configuration and creation of application objects)

The engineering of the substation single-line diagram is done either by creating a new application or by rebuilding an existing single-line process application done with LIB 500.

After base picture installation, the static background (busbars) of the single-line process picture is drawn with the picture editor. After that the MV process standard functions are installed in the picture, one by one. It is possible to draw the busbars either horizontally or vertically. If vertical busbars are used, more space is available for the bays. With vertical busbars, up to 40 bays can be installed into one picture.

The MV process representation pictures of the standard functions are available in three sizes. They can be installed vertically in two directions and horizontally in two directions.

Two symbol libraries are included in the package. Customer-specific symbols can be created by means of the representation editor.

Design

Switching devices are controlled from the operator workplace via the breaker control dialog. This control picture is automatically displayed when the switching device to be controlled is selected. Window call up is protected by authority handling to prevent unau-

thorized switch control. The control window is also linked to the control hierarchy so that the same object cannot be given a control command from two different workplaces at the same time.

Design (cont'd)

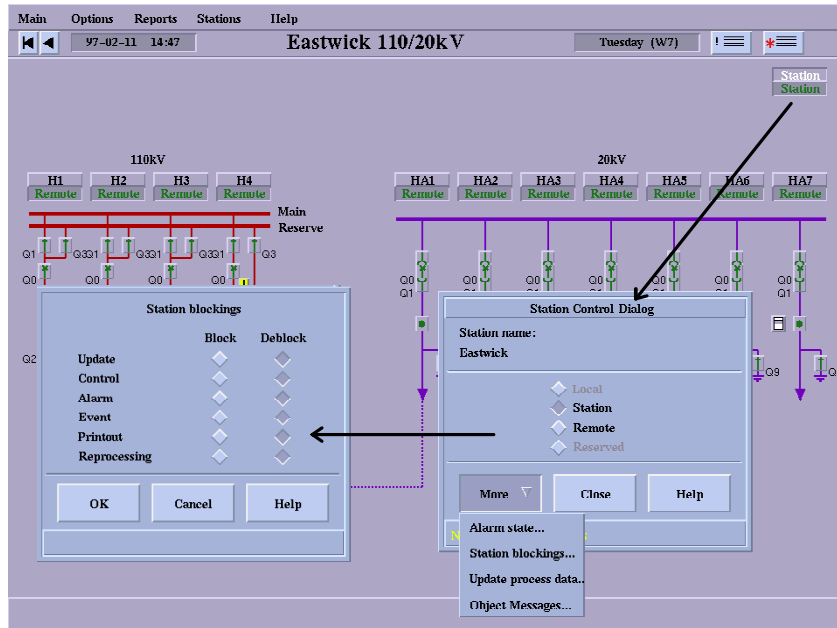

Fig. 1 Single-line diagram with blocking dialogs

Blocking conditions may be selected on station level, bay level and switchable device level.

Furthermore, there are dialogs for control, blocking, monitoring and setting functions for all standard functions used as building blocks for the single-line process picture.



Fig. 2 Dialog examples

The MV process package mainly supports SPACOM products, REC 501 and REF 54_ products, DTU products and the RTU 2__ range of products.

Standard functions include:

Design (cont'd)

- station: updating of data from the process to the station, station blocking/deblocking, local/remote handling
- bay: updating of data from the process to the bay, bay blocking/deblocking, bay interlocking
- switching device: breaker, disconnecter, three-state disconnecter, earth switch, truck, blocking/deblocking function, auto-reclose interruption, resetting of latched relays, trip tag, reclose tag
- measurements: up to four measurements per standard function, minimum and maximum value presentation, bar/unit presentation, zero deadband settings, fast trend curve presentation
- transformer: automatic and manual control mode operation, configurable min./max. position
- standard function support for LON protocol (e.g. REF 541)

Common functionality included in most standard functions:

- alarm state
- blockings
- state settings
- forced operation
- operation counting values presented
- object messages
- operation simulation function
- authorization handling
- help function available in all dialogs

SPA relay tool

This tool is used for SPACOM control and protection terminals, to configure, parameterize and create the needed process objects. All information recorded in the terminals is accessible for display presentation and the registers can be reset remotely. If the terminal has several parameter setting banks, these are interchangeable via the tool.

When the View Settings picture is selected, the parameters are read from the relay module. During the reading process, the parameters read are shown in a dialog.

The View Settings picture consist of two columns: main settings and second settings. Switching between these pictures can be made with the button 'Main/Second Setting'. At least the control authorization level is required to change the active settings.

The values recorded by the relay module are shown in the View Registrations pictures. The registers can be reset with this tool. In order to reset the relay registers, control authorization is needed. In the View Registrations pictures, the history values from the last trippings of the relay are shown.

The setting tool picture gives the relay engineer a powerful tool for monitoring and configuring the relay modules. The functionality and organization of the setting tool picture is similar to the relay parameterization and supervision part of the SMS 010 system.

Design (cont'd)

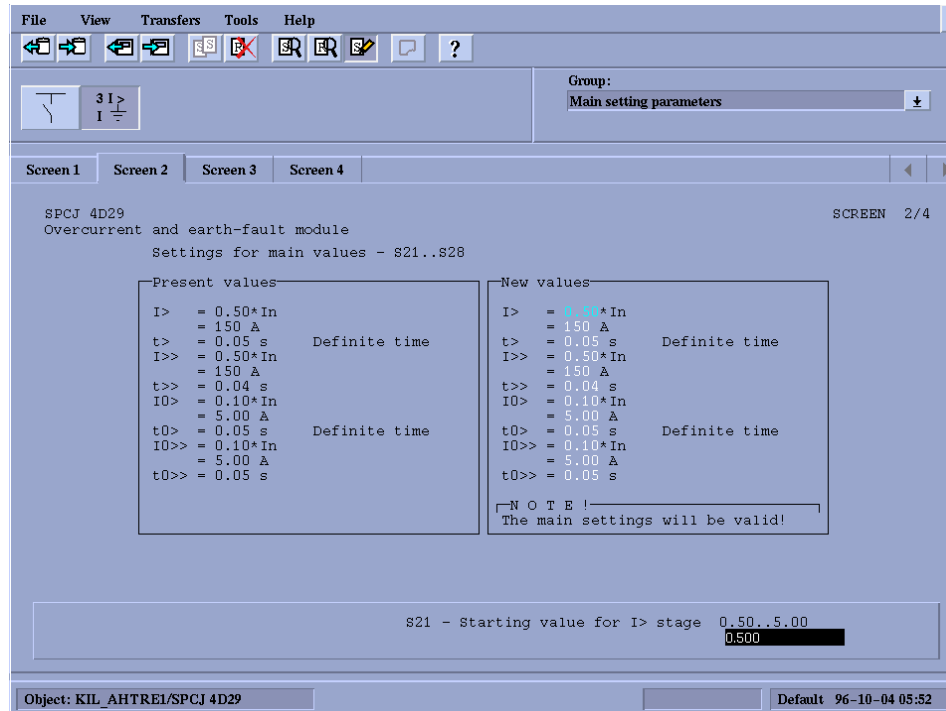

Fig. 3 Setting tool picture example

The setting tool pictures contain a presentation of present values and a presentation of new values. After changing of values, the new values have to be sent to the relay module by pressing the Save Changes button. The present values are also updated, when the values are saved.

The setting tool includes a default setting file for each type of SPACOM modules. These are derived from the SM/SPACOM package. Edited settings are stored in the system and/or sent to the target SPACOM module. The tool is able to directly read the default files, the files stored in the system and the parameters from the relay. To enhance the engineering efficiency, it is possible to select a group of parameters for uploading and downloading.

Features

- on-line parameterization
- off-line parameterization
- uploading/downloading of all parameters
- uploading/downloading groups of parameters
- selection of setting group
- reset of registers
- view parameters
- event handling

- changing of settings
- changing of setting bank
- reset register
- tool start-up from process picture or from control dialog
- alarm indication
- authorization support
- help function available in all dialogs

SM/SPACOM

SM/SPACOM includes files for all SPACOM units and for the REC 501. The files contain information about parameters, setting banks, events, registers and presentation windows. These files are used by the SPA relay tool.

Features

- SPA protocol support
- ANSI X3.28 protocol support
- SRIO 500/1000M support

Trend reports

The trend reports can be presented in graphical mode as full-graphic curves or in tabular mode. These two modes use the same process data, but otherwise they can be used independently.

Design (cont'd)

The graphical form of the LIB 510 trend picture contains up to ten curves from the process data log. They are presented as full-graphic curves on a two-dimensional coordinate system that consists of a horizontal time (X) axis and a vertical value (Y) axis. The

curves can be scrolled in both directions, X and Y. The parameters of both axis can be changed, as can the line-scaling parameters of the trend curves. All curves can temporarily be erased from the screen.

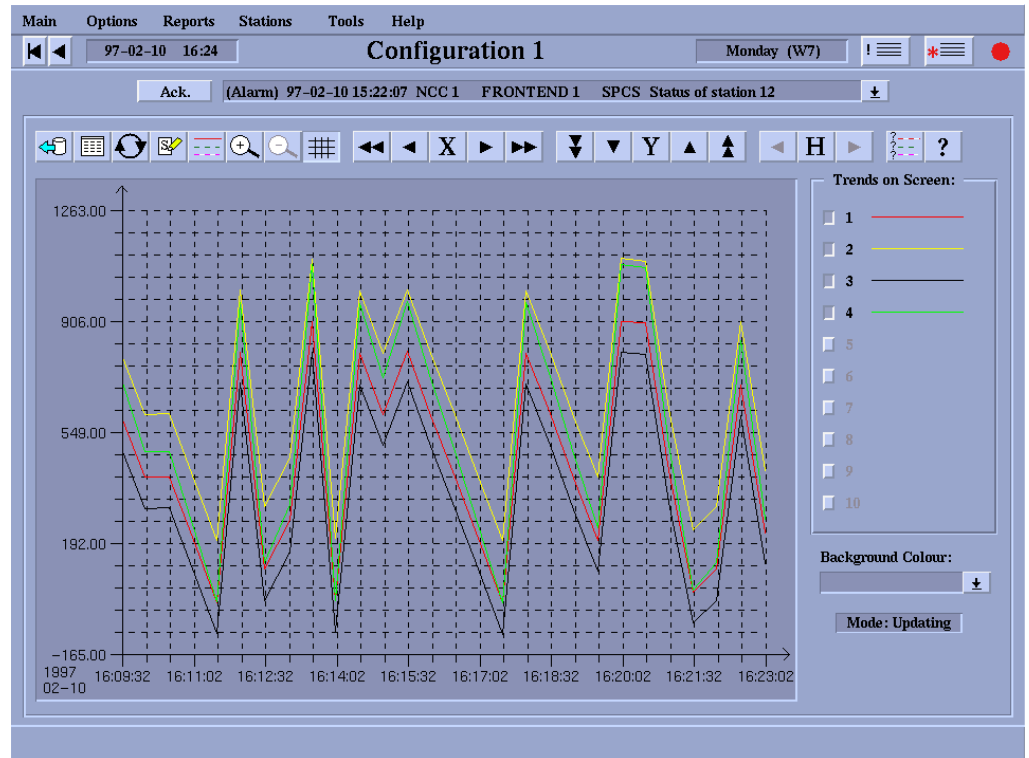

Fig. 4 Graphical presentation of a trend

Features

- graphical trend presentation of up to 10 curves
- tabular trend presentation of up to 10 columns
- hairline function
- colour configuration
- curve object identification
- line styles
- scalable axis
- scrolling in X and Y direction
- on/off switching of each curve
- process data logging activation from station picture
- update interval options from 30 seconds to 10 minutes
- 2880 measured items per curve
- calculation formulae; direct, mean, sum and difference

- trend data saving to file (possible to import to e.g. Excel)
- zoom function
- save/open preconfigurations
- possibility to enter values manually to a trend
- printout option
- authorization support
- help function available in all dialogs

Measurement report function

This standard function is used to build measurement reports such as energy and current reports within LIB 500 applications.

All data for the reports are calculated and stored in real time. Report data are collected and calculated either at certain points of time or after certain events. The most common method is to fetch raw data from the process, then refine it and store it in the report database.

Design (cont'd)

Collection and calculation of report data and printout of reports can be initiated in the following ways:

- as a result of a calculation
- based on a condition
- on the operator's request
- at predefined time intervals
- when a predefined event occurs

TIME	INNEN	HAFEN	TOTAL	BASIC	MID	PEAK	EXCESS	3H	MWH
00-01	60	55	115	55	42	18	0	0	
01-02	63	62	126	55	42	29	0	0	
02-03	60	60	121	55	42	24	0	0	120
03-04	59	51	110	55	42	4	0	0	
04-05	57	51	117	55	42	20	0	0	
05-06	54	54	107	55	42	10	0	0	108
06-07	57	63	120	55	42	23	0	0	
07-08	52	51	104	55	42	7	0	0	
08-09	56	56	112	55	42	15	0	0	112
09-10	54	53	106	55	42	9	0	0	
10-11	58	61	119	55	42	22	0	0	
11-12	63	59	133	55	42	30	0	0	119
12-13	62	59	120	55	42	23	0	0	
13-14	61	66	127	55	42	30	0	0	
14-15	62	63	126	55	42	26	0	0	124
15-16	62	66	128	55	42	30	0	1	
Day	529	544	1074	495	378	194	7		124
Night	400	406	806	385	294	127	0		120
Total	929	950	1880	880	672	321	7		124

Fig. 5 Report example

The following standard functions are included:

- active energy, base function
- reactive energy, base function
- energy reports: time columns, measured columns, measured columns (double tariff), total column, total column (double tariff), basic column, mid column, peak column, excess column, 1 h max. column, 3 h max. column, matrix column, matrix column (double tariff), day sum column, night sum column, max. day column, max. night column
- current report, base function: daily mean column, daily peak column, monthly mean column, monthly peak column, semiannual mean column, semiannual peak column, yearly mean column, yearly peak column, graphics report

DR collector tool

This tool is used for disturbance recorder units for uploading of disturbance recorder files. It requires the LIB 510 SPA relay tool and the LIB 510 SM/SPACOM tool.

The disturbance recorder is intended to be used for verifying the proper operation of protection relays and circuit breakers and for analyzing protection problems in electrical power systems.

The disturbance recorder captures the curve forms of the monitored quantities of the supervised object, both under normal service conditions and when the protection relays operate. Thus the relay settings can be based on the recorded information.

The recordings are saved in the COMTRADE format and they can be analyzed by evaluation tools which support this format, e.g. the REVAL disturbance evaluator. It is possible to run the evaluation program on the application machine or to evaluate the collected files in a separate machine.

Design (cont'd)

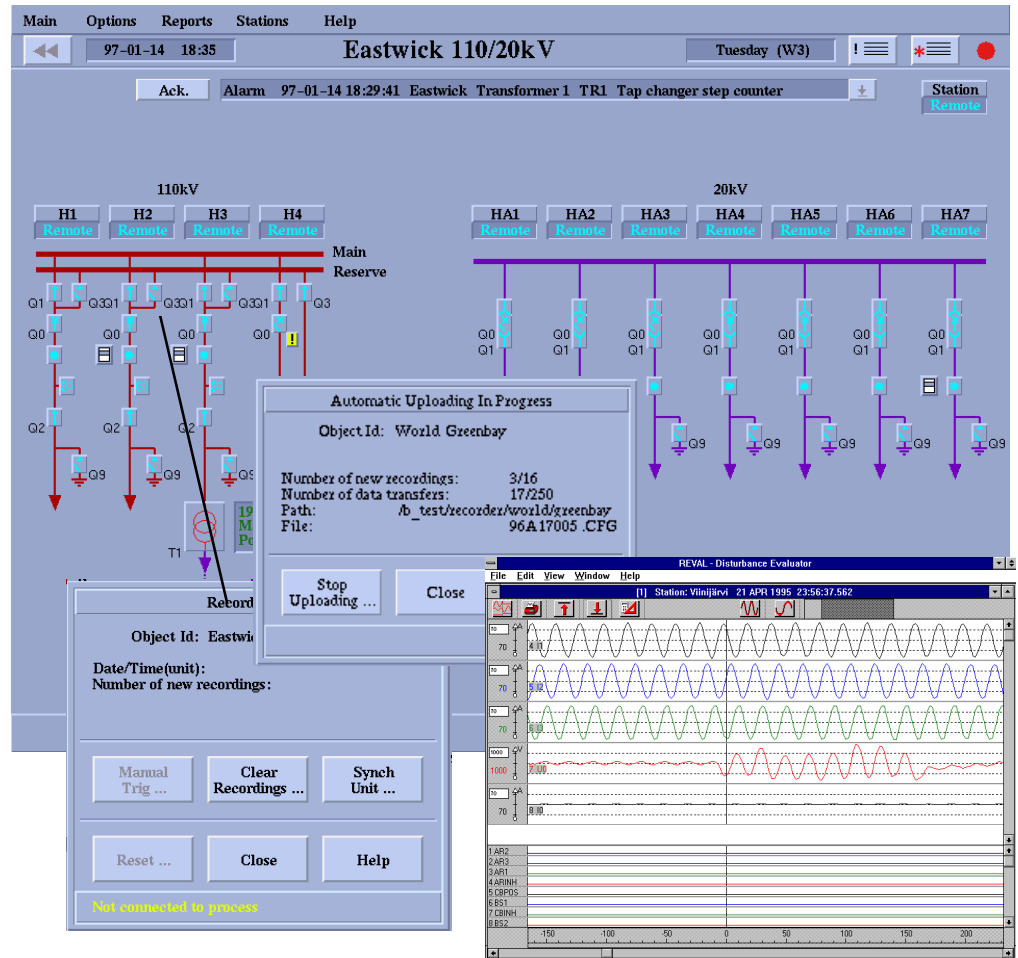

Fig. 6 Disturbance recording and evaluating tools

Supported SPACOM disturbance recorder modules:

- SPCR 8C19
- SPCR 8C27
- SPCD 3D53
- SPCD 2D55

Communication support:

- SPA
- ANSI X3.28 (SRIO 500/1000M)

Features

- disturbance recorder parameterization
- recording memory release
- configuring measuring signals
- configuring automatic upload parameters
- manual uploading
- automatic uploading (event-based)
- tool start-up from SPA relay tool
- authorization support
- help function available in all dialogs

Design (cont'd)

RED relay tool

The RED tools are used for configuring and setting of control and protection terminals built on the RED platform.

The parameter setting tool and the relay front panel mimic editor are included in the relay tool package.

As several tools have to be executed for a RED product, a start dialog is used for the tool selection. The dialog is opened when the RED relay object is selected in the process picture.

The parameter setting tool is used for changing settings and monitoring recorded data. The event masks are also set with this tool. A list of parameters and monitored values can be read directly from the relay, from a default file or from an edited file. Using the upload/download functions, all terminal values, a group of values or a single value can be updated.

The mimic editor is used for drawing the picture of a bay and the alarm display texts for the RED terminal mimic panel. The connection of picture objects to a certain database object in the relay can also be done in this tool.

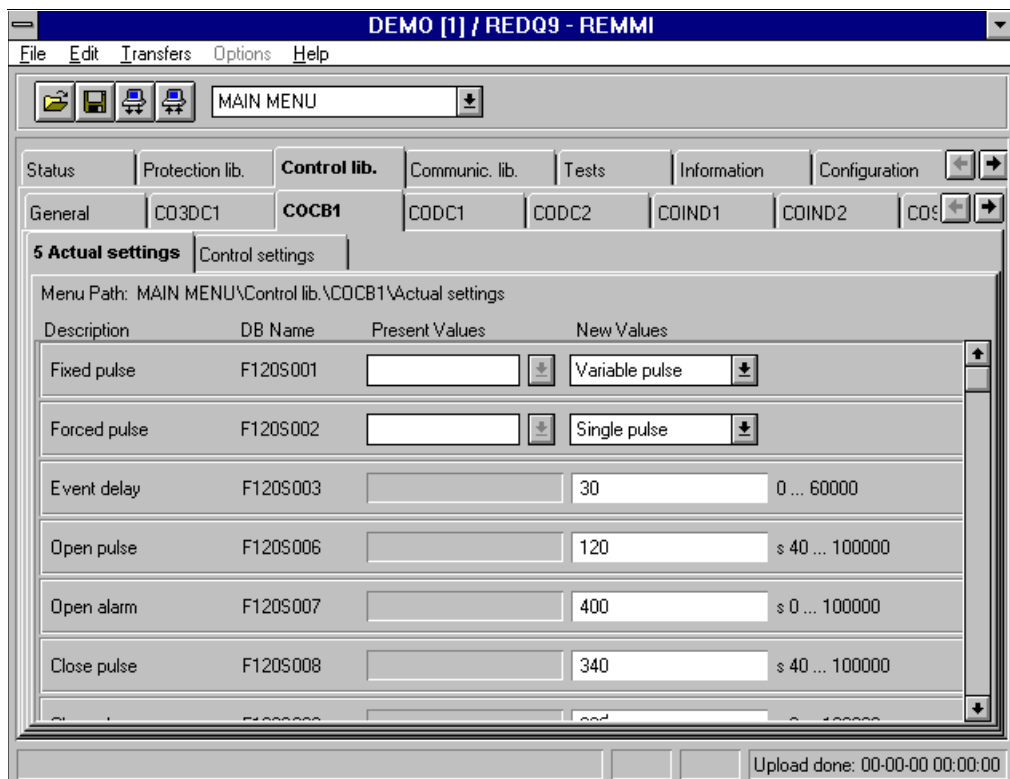

Fig. 7 The RED relay tool

Features

- view settings
- view registers
- event handling
- on-line parameterization
- off-line parameterization
- off-line mimic configuration
- on-line mimic configuration
- uploading/downloading of all parameters
- uploading/downloading of a group of parameters
- selection of setting group
- changing of setting group
- resetting of registers
- start-up either from the process picture or from the control dialog
- authorization support
- help function in all dialogs

Product Guide

SM/RED

The SM/RED package includes a set of RE_5_ unit descriptions to be used with the RED relay tool. These descriptions contain information about parameters, setting banks, events, registers and presentation windows.

Features

- requires the RED Relay Tool
- RE_54_ unit support

Technical data

Table 1: General requirement

LIB 500 v. 4.2 requires the MicroSCADA 8.4.4. or MicroSCADA Pro.
--

Echelon and LON are registered trademarks of Echelon Corporation.

All other product names are trademarks, registered trademarks, or service marks of their respective owners.



ABB Oy
Distribution Automation
P.O. Box 699
FI-65101 Vaasa, FINLAND
Tel +358 10 22 11
Fax +358 10 224 1094
www.abb.com/substationautomation