

# Voltage Relay REU610

Technical Reference Manual - ANSI Version





## Contents

<b>Copyrights .....</b>	<b>5</b>
<b>1. Introduction .....</b>	<b>7</b>
1.1. This manual .....	7
1.2. Use of symbols .....	7
1.3. Intended audience .....	7
1.4. Product documentation .....	8
1.5. Document conventions .....	8
1.6. Document revisions .....	9
<b>2. Safety information .....</b>	<b>11</b>
<b>3. Product overview .....</b>	<b>13</b>
3.1. Use of the relay .....	13
3.2. Features .....	13
<b>4. Application .....</b>	<b>15</b>
4.1. Requirements .....	15
4.2. Configuration .....	15
<b>5. Technical description .....</b>	<b>17</b>
5.1. Functional description .....	17
5.1.1. Product functions .....	17
5.1.1.1. Protection functions .....	17
5.1.1.2. Inputs .....	17
5.1.1.3. Outputs .....	18
5.1.1.4. Disturbance recorder .....	18
5.1.1.5. Front panel .....	18
5.1.1.6. Non-volatile memory .....	19
5.1.1.7. Self-supervision .....	19
5.1.1.8. Time synchronization .....	20
5.1.2. Measurements .....	21
5.1.3. Configuration .....	22
5.1.4. Protection .....	24
5.1.4.1. Block diagram .....	24
5.1.4.2. Overvoltage protection .....	24
5.1.4.3. Undervoltage protection .....	26
5.1.4.4. Residual overvoltage protection .....	29
5.1.4.5. Circuit-breaker failure protection .....	30
5.1.4.6. Inverse definite minimum time characteristics .....	31
5.1.4.7. Settings .....	37
5.1.4.8. Technical data on protection functions .....	47
5.1.5. Trip-circuit supervision .....	49

- 5.1.6. Trip lockout function ..... 50
- 5.1.7. Trip counters for circuit-breaker condition monitoring ..... 51
- 5.1.8. Target LEDs and operation target messages .... 51
- 5.1.9. Demand values ..... 52
- 5.1.10. Commissioning tests ..... 52
- 5.1.11. Disturbance recorder ..... 53
  - 5.1.11.1. Function..... 53
  - 5.1.11.2. Disturbance recorder data..... 53
  - 5.1.11.3. Control and target of disturbance recorder status..... 54
  - 5.1.11.4. Triggering..... 55
  - 5.1.11.5. Settings and unloading..... 55
  - 5.1.11.6. Event code of the disturbance recorder ..... 55
- 5.1.12. Recorded data of the last events ..... 55
- 5.1.13. Communication ports..... 57
- 5.1.14. IEC 60870-5-103 remote communication protocol..... 58
- 5.1.15. Modbus remote communication protocol ..... 61
  - 5.1.15.1. Profile of Modbus ..... 62
- 5.1.16. DNP 3.0 remote communication protocol ..... 74
  - 5.1.16.1. Protocol parameters..... 74
  - 5.1.16.2. DNP 3.0 point list ..... 74
  - 5.1.16.3. DNP 3.0 device profile ..... 77
  - 5.1.16.4. Specific DNP features ..... 83
- 5.1.17. SPA bus communication protocol parameters ... 86
  - 5.1.17.1. Event codes ..... 99
- 5.1.18. Self-supervision (IRF) system ..... 103
- 5.1.19. Relay parameterization ..... 105
- 5.2. Design description ..... 105
  - 5.2.1. Input/output connections ..... 105
  - 5.2.2. Serial communication connections ..... 111
  - 5.2.3. Technical data ..... 117
- 6. Ordering information ..... 123**
- 7. Check lists ..... 125**
- 8. Abbreviations ..... 131**

## Copyrights

The information in this document is subject to change without notice and should not be construed as a commitment by ABB Oy. ABB Oy assumes no responsibility for any errors that may appear in this document.

In no event shall ABB Oy be liable for direct, indirect, special, incidental or consequential damages of any nature or kind arising from the use of this document, nor shall ABB Oy be liable for incidental or consequential damages arising from use of any software or hardware described in this document.

This document and parts thereof must not be reproduced or copied without written permission from ABB Oy, and the contents thereof must not be imparted to a third party nor used for any unauthorized purpose.

The software or hardware described in this document is furnished under a license and may be used, copied, or disclosed only in accordance with the terms of such license.

© Copyright 2009 ABB Oy

All rights reserved.

## Trademarks

ABB is a registered trademark of ABB Group. All other brand or product names mentioned in this document may be trademarks or registered trademarks of their respective holders.

## Warranty

Please inquire about the terms of warranty from your nearest ABB representative.



## 1. Introduction

### 1.1. This manual

This manual provides thorough information on the voltage relay REU610 and its applications, focusing on giving a technical description of the relay.

Refer to the Operator's Manual for instructions on how to use the human-machine interface (HMI) of the relay, also known as the man-machine interface (MMI), and to the Installation Manual for installation of the relay.

### 1.2. Use of symbols

This publication includes the following icons that point out safety-related conditions or other important information:



The electrical warning icon indicates the presence of a hazard which could result in electrical shock.



The warning icon indicates the presence of a hazard which could result in personal injury.



The caution icon indicates important information or warning related to the concept discussed in the text. It might indicate the presence of a hazard which could result in corruption of software or damage to equipment or property.



The information icon alerts the reader to relevant facts and conditions.



The tip icon indicates advice on, for example, how to design your project or how to use a certain function.

Although warning hazards are related to personal injury, it should be understood that operation of damaged equipment could, under certain operational conditions, result in degraded process performance leading to personal injury or death. Therefore, comply fully with all warning and caution notices.

### 1.3. Intended audience

This manual is intended for operators and engineers to support normal use of as well as configuration of the product.

### 1.4. Product documentation

In addition to the relay and this manual, the delivery contains the following relay-specific documentation:

**Table 1.4.-1 REU610 product documentation**



Name	Document ID
Certificate of verification	1MRS081662
Installation Manual	1MRS752265-MUM
Operator's Manual	1MRS755971

**Table 1.4.-2 Other reference documentation for REU610**

Name	Document ID
Modicon Modbus Protocol Reference Guide, Rev. E	PI-MBUS-300

### 1.5. Document conventions

The following conventions are used for the presentation of material:

- Push button navigation in the human-machine interface (HMI) menu structure is presented by using the push button icons, for example:  
To navigate between the options, use  and .
- HMI menu paths are presented as follows:  
Use the arrow buttons to select CONFIGURATION\ COMMUNICATION\ SPA SETTINGS\ PASSWORD SPA.
- Parameter names, menu names, relay target messages and relay's HMI views are shown in a Courier font, for example:  
Use the arrow buttons to monitor other measured values in the menus DEMAND VALUES and HISTORY DATA.
- HMI messages are shown inside quotation marks when it is good to point out them for the user, for example:  
When you store a new password, the relay confirms the storage by flashing “- - -” once on the display.

**1.6.****Document revisions**

<b>Version</b>	<b>IED Revision</b>	<b>Date</b>	<b>History</b>
A	A	01.02.2006	Document created
B	C	01.10.2007	Content updated
C	C	12.12.2007	Added information related to ordering parts and accessories.
D	C	22.05.2009	Content updated



## 2. Safety information



Dangerous voltages can occur on the connectors, even though the auxiliary voltage has been disconnected.

Non-observance can result in death, personal injury or substantial property damage.

Only a competent electrician is allowed to carry out the electrical installation.

National and local electrical safety regulations must always be followed.

The frame of the device has to be carefully grounded.

When the plug-in unit has been detached from the case, do not touch the inside of the case. The relay case internals may contain high voltage potential and touching these may cause personal injury.



The device contains components which are sensitive to electrostatic discharge. Unnecessary touching of electronic components must therefore be avoided.

Breaking the sealing tape on the upper handle of the device will result in loss of guarantee and proper operation will no longer be insured.



## 3. Product overview

### 3.1. Use of the relay

The voltage relay REU610 is a versatile multifunction protection relay mainly designed for overvoltage and undervoltage protection and for supervision of medium voltage distribution networks. The relay can also be used for protecting generators, motors and transformers.

The relay is based on a microprocessor environment. A self-supervision system continuously monitors the operation of the relay.

The HMI includes a liquid crystal display (LCD) which makes the local use of the relay safe and easy.

Local control of the relay via serial communication can be carried out with a computer connected to the front communication port. Remote control can be carried out via the rear connector connected to the control and monitoring system through the serial communication bus.

### 3.2. Features

- Overvoltage protection with definite-time or IDMT characteristic, low-set element
- Overvoltage protection with definite-time or IDMT characteristic, high-set element
  - Based on phase-to-phase voltage measurement or negative phase-sequence (NPS) voltage
- Undervoltage protection with definite-time or IDMT characteristic, low-set element
  - Can also be used as alarm element
- Undervoltage protection with definite-time or IDMT characteristic, high-set element
  - Based on phase-to-phase voltage measurement or positive phase-sequence (PPS) voltage
- Residual overvoltage protection with definite-time characteristic, low-set element
- Residual overvoltage protection with definite-time characteristic, high-set element
- Circuit-breaker failure protection
- Trip counters for circuit-breaker condition monitoring
- Trip-circuit supervision with possibility to route the warning signal to a non-trip output
- Trip lockout function
- Four accurate voltage inputs
  - User-selectable rated voltage 100/110/115/120 V
- User-selectable rated frequency 50/60 Hz

- Three normally open trip contacts
- Two change-over (form c) non-trip contacts and three additional change-over (form c) non-trip contacts on the optional I/O module
- Output contact functions freely configurable for wanted operation
- Two galvanically isolated digital inputs and three additional galvanically isolated digital inputs on the optional I/O module
- Disturbance recorder:
  - Recording time up to 80 seconds
  - Triggering by one or several internal or digital input signals
  - Records four analog channels and up to eight user-selectable digital channels
  - Adjustable sampling rate
- Non-volatile memory for:
  - Up to 100 event codes with time stamp
  - Setting values
  - Disturbance recorder data
  - Recorded data of the five last events with time stamp
  - Number of pickups for protection elements
  - Operation target messages and LEDs showing the status at the moment of power failure
- HMI with an alphanumeric LCD and navigation buttons
  - Eight programmable LEDs
- Multi-language support
- User-selectable password protection for the HMI
- Display of primary voltage values
- All settings can be modified with a PC
- Optical front communication connection: wirelessly or via cable
- Optional rear communication module with plastic fibre-optic, combined fibre-optic (plastic and glass) or RS-485 connection for system communication using the SPA-bus, IEC 60870-5-103 or Modbus (RTU and ASCII) communication protocol
- Optional DNP 3.0 rear communication module with RS-485 connection for system communication using the DNP 3.0 communication protocol
- Battery back-up for real-time clock
- Time synchronization via a digital input
- Battery charge supervision
- Continuous self-supervision of electronics and software
  - At an internal relay fault, all protection elements and outputs are locked
- Detachable plug-in unit

## 4. Application

REU610 is a versatile multifunction voltage relay which is used in general voltage supervision applications. It complements the range of feeder protection relay REF610 and motor protection relay REM610 in industrial outgoing feeder and motor feeder applications. The relay can also be used as back-up protection for industrial as well as utility applications.

The large number of integrated protection functions, including two overvoltage protection elements, two undervoltage protection elements and two residual overvoltage protection elements, makes the relay a complete protection against various voltage fault conditions.

The large number of digital inputs and output contacts allows a wide range of applications.

### 4.1. Requirements

To secure correct and safe operation of the relay, preventive maintenance is recommended to be performed every five years when the relay is operating under the specified conditions; see Table 4.1.-1 and Section 5.2.3. Technical data.

When being used for real-time clock or recorded data functions, the battery should be changed every five years.

**Table 4.1.-1 Environmental conditions**

Recommended temperature range (continuous)	-10...+55°C
Limit temperature range (short-term)	-40...+70°C
Temperature influence on the operation accuracy of the voltage relay within the specified service temperature range	0.1%/°C
Transport and storage temperature range	-40...+85°C

### 4.2. Configuration

The appropriate configuration of the output contact matrix enables the use of the signals from the protection elements as contact functions. The pickup signals can be used for blocking co-operating protection relays and signalling.

The Fig. 4.2.-1 represents the relay with trip lockout function and external reset switch.

Technical Reference Manual - ANSI Version

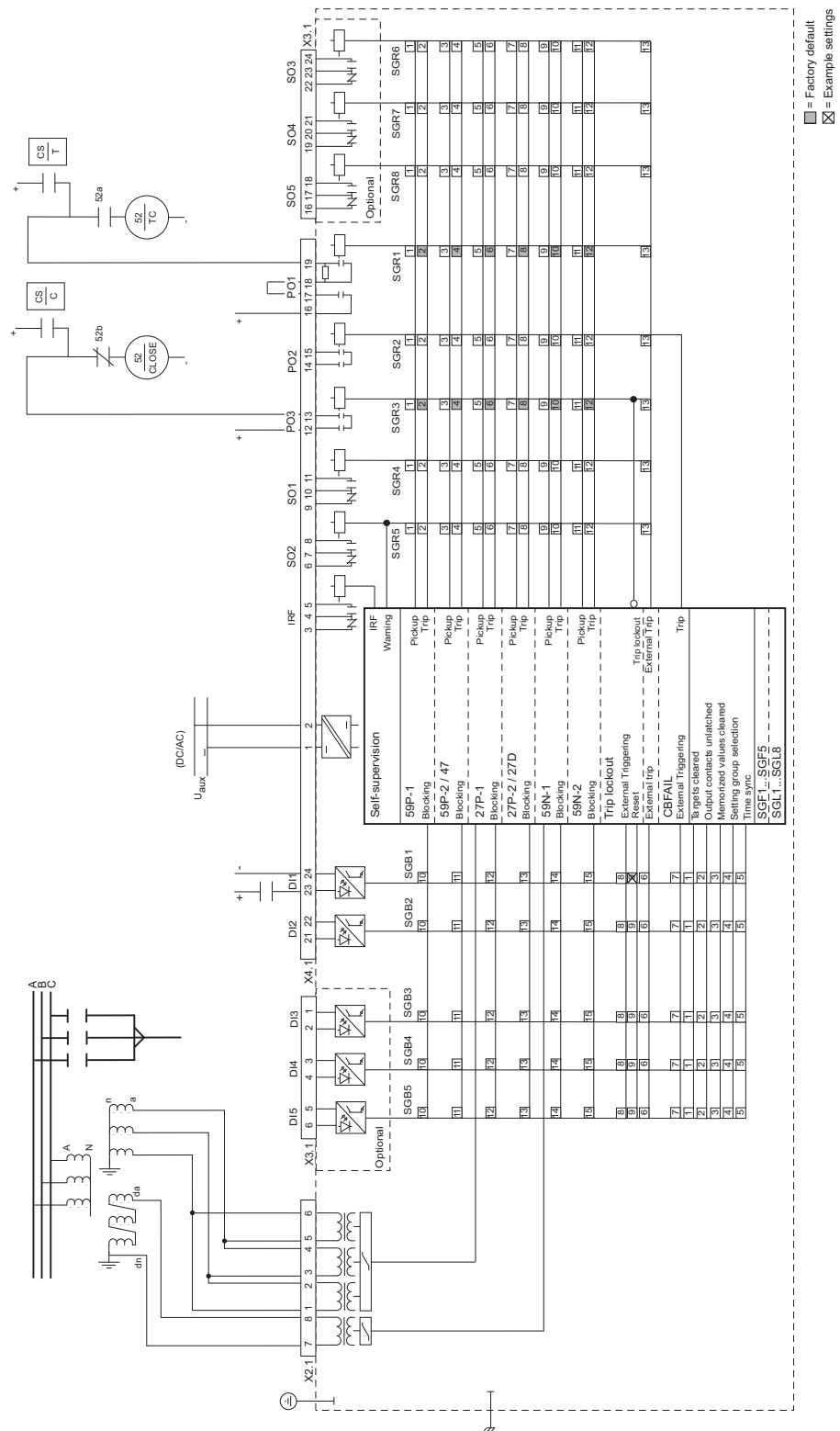

Fig. 4.2.-1 Connection diagram

A051896\_2

## 5. Technical description

### 5.1. Functional description

#### 5.1.1. Product functions

##### 5.1.1.1. Protection functions

**Table 5.1.1.1.-1 IEC symbols and IEEE device numbers**

Function description	IEC symbol	IEEE device number
Overvoltage protection, low-set element	U>	59P-1
Overvoltage protection, high-set element	U>>	59P-2
Negative phase-sequence overvoltage protection	U <sub>2</sub> >	47
Undervoltage protection, low-set element	U<	27P-1
Undervoltage protection, high-set element	U<<	27P-2
Positive phase-sequence undervoltage protection	U <sub>1</sub> <	27D
Residual overvoltage protection, low-set element	U <sub>0</sub> >	59N-1
Residual overvoltage protection, high-set element	U <sub>0</sub> >>	59N-2
Circuit-breaker failure protection	CBFP	CBFAIL
Lockout relay		86

For protection function descriptions, refer to Section 5.1.4. Protection.

##### 5.1.1.2. Inputs

The relay is provided with four energizing inputs, two digital inputs and three optional digital inputs controlled by an external voltage. Three of the energizing inputs are for the phase-to-phase voltages and one for the residual voltage.



The relay is mainly designed to measure phase-to-phase voltages, but it can be used for measuring phase-to-ground voltages as well. However, the relay does not convert the voltage from phase-to-ground voltage to phase-to-phase voltage.

The functions of the digital inputs are determined with the SGB switches. For details, refer to Section 5.2.1. Input/output connections and Table 5.1.4.7.-7, Table 5.2.1.-1 and Table 5.2.1.-5.

### 5.1.1.3. Outputs

The relay is provided with:

- Three trip output contacts PO1, PO2 and PO3
- Two non-trip output contacts SO1 and SO2
- Three optional non-trip output contacts SO3, SO4 and SO5

Switchgroups SGR1...8 are used for routing internal signals from the protection elements and the external trip signal to the wanted non-trip or trip output contact. The minimum pulse length can be configured to be 40 or 80 ms and the trip output contacts can be configured to be latched.

### 5.1.1.4. Disturbance recorder

The relay includes an internal disturbance recorder which records the instantaneous measured values or the RMS curves of the measured signals, and up to eight user-selectable digital signals: the digital input signals and the internal signals from the protection elements. Any digital signal can be set to trigger the recorder on either the falling or rising edge.

### 5.1.1.5. Front panel

The front panel of the relay contains:

- Alphanumeric 2 × 16 characters' LCD with backlight and automatic contrast control
- Threetarget LEDs (green, yellow, red) with fixed functionality
- Eight programmable target LEDs (red)
- HMI push-button section with four arrow buttons and buttons for clear/cancel and enter, used in navigating in the menu structure and in adjusting setting values
- Optically isolated serial communication port with a target LED.

There are two levels of HMI passwords; main HMI setting password for all settings and HMI communication password for communication settings only.

The HMI passwords can be set to protect all user-changeable values from being changed by an unauthorized person. Both the HMI setting password and the HMI communication password remain inactive and are not required for altering parameter values until the default HMI password is replaced.



Entering the HMI setting or communication password successfully can be selected to generate an event code. This feature can be used to indicate interaction activities via the local HMI.

For further information on the HMI, refer to the Operator's Manual.

### 5.1.1.6. Non-volatile memory

The relay can be configured to store various data in a non-volatile memory, which retains its data also in case of loss of auxiliary voltage (provided that the battery has been inserted and is charged). Operation target messages and LEDs, disturbance recorder data, event codes and recorded data can all be configured to be stored in the non-volatile memory whereas setting values and trip counters are always stored in the EEPROM. The EEPROM does not require battery backup.

### 5.1.1.7. Self-supervision

The self-supervision system of the relay manages run-time fault situations and informs the user about an existing fault. There are two types of fault targets; internal relay fault (IRF) targets and warnings. Internal relay faults prevent relay operation. Warnings are less severe faults and continued relay operation with full or reduced functionality is allowed.

#### Internal relay fault (IRF)

When the self-supervision system detects a permanent internal relay fault, the green target LED starts to flash. At the same time, the IRF contact (also referred to as the IRF relay), which is normally picked up, drops off. The text INTERNAL FAULT and a fault code appear on the display.



Fig. 5.1.1.7.-1 Permanent IRF

A040278

#### Warning

In case of a less severe fault (warning), the relay continues to operate except for those protection functions possibly affected by the fault. At this type of fault, the green target LED remains lit as during normal operation, but the text WARNING with a fault code or a text message indicating the fault type appears on the LCD. In case of a warning due to an external fault in the trip circuit detected by the trip-circuit supervision, SO2 is activated (if SGF1/8=1).



A040279

Fig. 5.1.1.7.-2 Warning with text message



A040280

Fig. 5.1.1.7.-3 Warning with numeric code

For fault codes, refer to 5.1.18. Self-supervision (IRF) system

### 5.1.1.8. Time synchronization

Time synchronization of the relay’s real-time clock can be realized in two different ways: via serial communication using a communication protocol or via a digital input.

When time synchronization is realized via serial communication, the time is written directly to the relay’s real-time clock.

Any digital input can be configured for time synchronization and used for either minute-pulse or second-pulse synchronization. The synchronization pulse is automatically selected and depends on the time range within which the pulse occurs. Two detected pulses within acceptable time range are required before the relay activates pulse synchronization. Respectively, if the synchronization pulses disappear, the relay takes time that corresponds to the time range of four pulses before de-activating pulse synchronization. The time must be set once, either via serial communication or manually via the HMI.

When the time is set via serial communication and minute-pulse synchronization is used, only year-month-day-hour-minute is written to the relay’s real-time clock, and when second-pulse synchronization is used, only year-month-day-hour-minute-second is written. The relay’s real-time clock will be rounded to the nearest whole second or minute, depending on whether second- or minute-pulse synchronization is used. When the time is set via the HMI, the entire time is written to the relay’s real-time clock.

If the synchronization pulse differs more than  $\pm 0.05$  seconds for second-pulse or  $\pm 2$  seconds for minute-pulse synchronization from the relay's real-time clock, the synchronization pulse is rejected.

Time synchronization is always triggered on the rising edge of the digital input signal. The time is adjusted by accelerating or decelerating the relay's clock. By this way the clock neither stops nor makes sudden jumps during the time adjustment. The typical accuracy achievable with time synchronization via a digital input is  $\pm 2.5$  milliseconds for second-pulse and  $\pm 5$  milliseconds for minute-pulse synchronization.



The pulse length of the digital input signal does not affect time synchronization.



If time synchronization messages are received from a communication protocol as well, they have to be synchronized within  $\pm 0.5$  minutes at minute-pulse or  $\pm 0.5$  seconds at second-pulse synchronization. Otherwise the time difference may appear as rounding errors. If it is possible that the synchronization messages from the communication protocol are delayed more than 0.5 seconds, minute-pulse synchronization must be used.

When the minute-pulse synchronization is active and long time format is sent via a communication protocol, the protocol's second and millisecond part is ignored. The protocol's minute part is rounded to the nearest minute. Short time format is ignored altogether.

When the second-pulse synchronization is active and long or short time format is sent via a communication protocol, the protocol's millisecond part is ignored. The protocol's second-part is rounded to the nearest second.

## 5.1.2.

### Measurements

The table below presents the measured values which can be accessed through the HMI.

**Table 5.1.2.-1 Measured values**

Target	Description
$U_{ab}$	Measured phase-to-phase voltage $U_{ab}$
$U_{bc}$	Measured phase-to-phase voltage $U_{bc}$
$U_{ca}$	Measured phase-to-phase voltage $U_{ca}$
$U_n$	Measured residual voltage $U_n$
$U_1$	Positive phase-sequence voltage
$U_2$	Negative phase-sequence voltage

Target	Description
1 minute	The average voltage of the three phase-to-phase voltages during one minute
n minute	The average voltage of the three phase-to-phase voltages during the specified time range
Max	The maximum of one-minute average voltage of the n minute
$U_{max}$	The maximum voltage of the three phase-to-phase voltages since the last reset (with timestamp)
$U_{min}$	The minimum voltage of the three phase-to-phase voltages since the last reset (with timestamp)

### 5.1.3.

### Configuration

The Fig. 5.1.3.-1 illustrates how the internal and digital input signals can be configured to obtain the required protection functionality.

Technical Reference Manual - ANSI Version

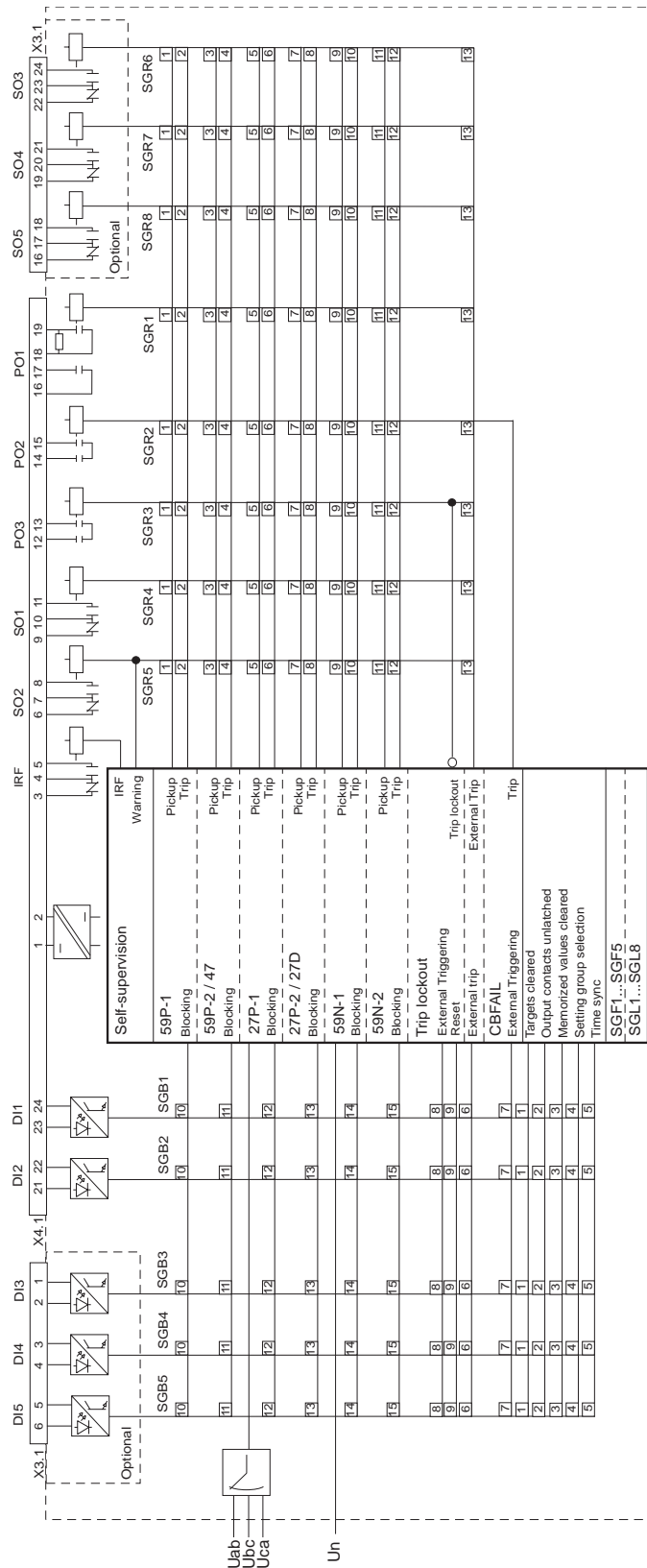
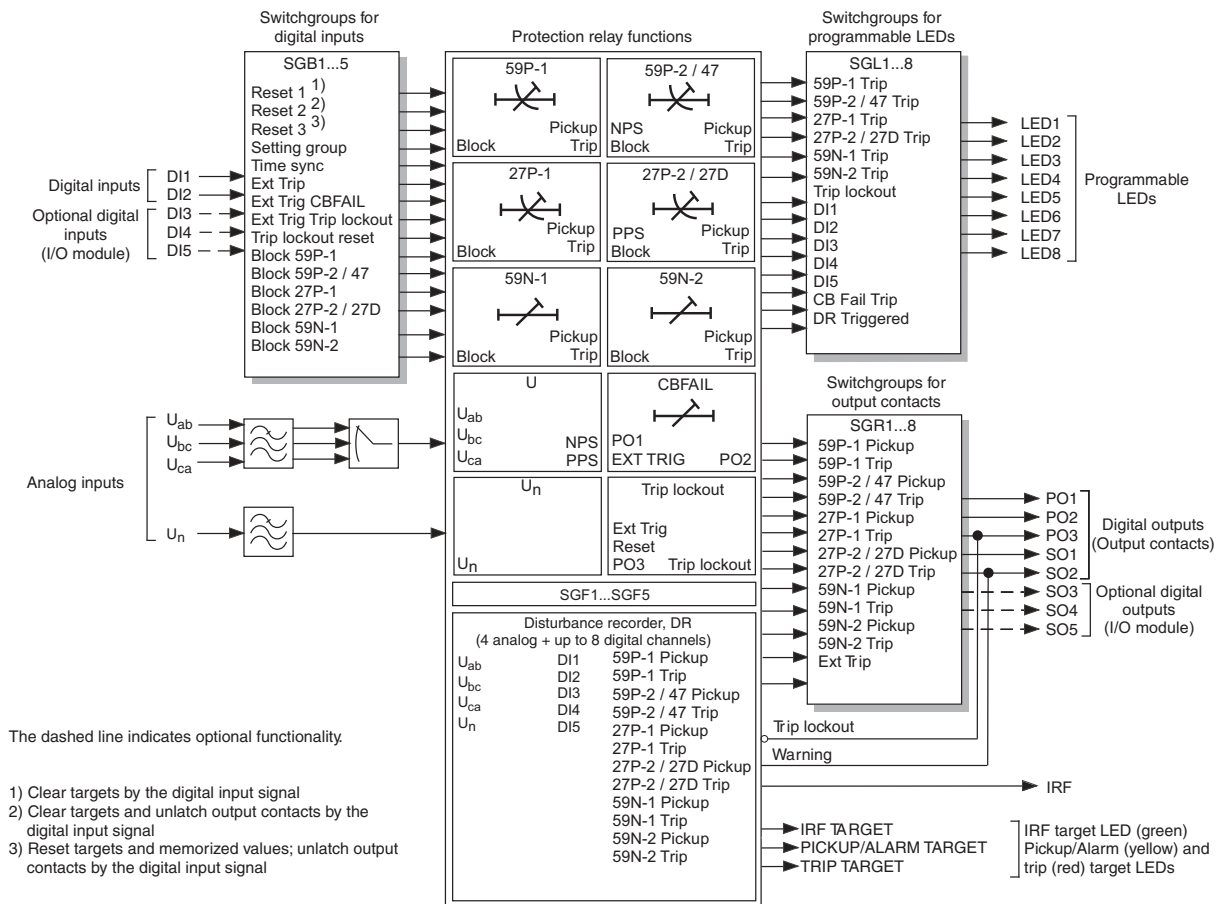

Fig. 5.1.3.-1 Signal diagram

The functions of the relay are selected with the switches of switchgroups SGF, SGB, SGR and SGL. The checksums of the switchgroups are found under SETTINGS in the HMI menu. The functions of the switches are explained in detail in the corresponding SG\_ tables.

5.1.4. Protection

5.1.4.1. Block diagram



A052076\_2

Fig. 5.1.4.1.-1 Block diagram

5.1.4.2. Overvoltage protection

The overvoltage protection can be based on either conventional voltage measurement or calculated negative phase-sequence voltage.

The low-set overvoltage element 59P-1 is based on conventional voltage measurement.

The high-set overvoltage element 59P-2 can be set to be based on either

- Conventional voltage measurement (59P-2 mode selected), or
- Calculated negative phase-sequence voltage (47 mode selected).

The selection between these modes is made either by using HMI or parameter *S7*, the default setting being conventional measurement. Element 27D (PPS) and 47 (NPS) cannot be used at the same time.

Element 59P-2 can be set out of operation in SGF3/1. This state is indicated by dashes on the LCD and by “999” when the set pickup value is read via serial communication.



It is possible to block the tripping of an overvoltage element by applying a digital input signal to the relay.

### **Overvoltage protection based on conventional voltage measurement**

Both the low-set and the high-set overvoltage element can independently be set to pickup and trip when one of the three voltages or all the voltages rise above the set start value. By default, both elements operate when one of the three voltages rise above the set pickup value. The selection is made in SGF4/5 and SGF4/6.

When the phase-to-phase voltage values exceed the set pickup value of the low-set element 59P-1, the element generates a pickup signal after a ~ 60 ms' pickup time. When the set operate time at definite-time characteristic or the calculated operate time at IDMT characteristic elapses, the element generates a trip signal.

Element 59P-1 has a settable resetting time (both at definite-time and IDMT characteristics), 59P-1 RESET, for reset coordination with existing electromechanical relays or for reducing fault clearance times of recurring, transient faults. If element 59P-1 has picked up and the phase-to-phase voltages fall below the set pickup value of the element, the pickup of the element remains active for the set resetting time. If the phase-to-phase voltages exceed the set pickup value again while the timer is running, the timer is cleared and the pickup of the element remains active.

Consequently, the set resetting time ensures that when the element picks up because of voltage spikes, it is not immediately reset. If element 59P-1 has already tripped, the element is reset in 70 ms after the phase-to-phase voltages have fallen below 0.5 times the set pickup value of the element. However, if element 59P-1 has already tripped and the phase-to-phase voltages have fallen below the set pickup value of the element, but not below 0.5 times the set pickup value, the element is reset when the set resetting time is expired.

When the conventional protection mode is selected and the phase-to-phase voltages exceed the set pickup value of the high-set element, 59P-2, the element generates a pickup signal after a ~ 50 ms' pickup time. When the set operate time at definite-

time characteristic or the calculated operate time at IDMT characteristic elapses, the element generates a trip signal. The element is reset in 70 ms after the phase-to-phase voltages have fallen below the set pickup value of the element.

The conventional overvoltage elements have a settable drop-off/pick-up ratio, which is adjustable between 0.95...0.99, the default being 0.97.



The settable drop-off/pick-up ratio enables the voltage protection to satisfactorily work with a voltage regulator, for instance, such as a tap changer. The tap changer step is often 1.67%, which is less than the drop-off/pick-up ratio of voltage relays. This can cause a situation where the voltage protection remains active even though the tap changer already has changed the voltage.

### Overvoltage protection based on negative phase-sequence voltage

When the calculated negative phase-sequence voltage value  $U_2$  exceeds the set pickup value of the element 47, the element generates a pickup signal after a 50 ms' pickup time. When the set operate time at definite-time characteristics or the calculated operate time at IDMT characteristics elapses, the element generates a trip signal. The element is reset in 70 ms after the calculated negative phase-sequence voltage value has fallen below the set pickup value of the element.

The negative phase-sequence voltage is calculated as follows:

$$\underline{U}_2 = \frac{\underline{U}_{ab} + a^2 \times \underline{U}_{bc} + a \times \underline{U}_{ca}}{3} \quad (1)$$

$$a = 1 \angle 120^\circ$$

$$a^2 = 1 \angle -120^\circ$$

The negative phase-sequence value is scaled to the amplitude of the measured voltage. On a network with a reverse phase order, the calculated negative phase-sequence value has the same amplitude as the measured voltage signal.

Element 47 can be set to be blocked when one of the measured phase-to-phase voltages falls below  $0.15 \times U_n$  (VT). The selection is made in SGF4.

Element 47 has a fixed drop-off/pick-up ratio of 0.96.

#### 5.1.4.3.

### Undervoltage protection

The undervoltage protection can be based on either conventional voltage measurement or the calculated positive phase-sequence voltage.

The low-set undervoltage element 27P-1 is based on conventional voltage measurement. The low-set element can also be used for alarm purposes.

The high-set undervoltage element 27P-2 can be set to be based on either:

- Conventional voltage measurement (27P-2 mode selected) or
- Calculated positive phase-sequence voltage (27D mode selected).

The selection between these modes is made either by using HMI or parameter  $S7$ , the default setting being conventional measurement. Element 27D (PPS) and 47 (NPS) cannot be used at the same time.

The undervoltage elements can be set to be blocked when one of the measured voltages fall below  $0.15 \times U_n$  (VT). The blocked element is reset after the set resetting time. This feature can be used to avoid unnecessary pickups and trips during, for example, an auto-reclose sequence. In addition, the tripping of element 27P-1 can be set to be blocked by the element 27P-2 pickup. The selection is made in SGF4.

Element 27P-2 or 27D can be set out of operation in SGF3/2. This state is indicated by dashes on the LCD and by 999 when the set pickup value is read via serial communication.



It is possible to block the tripping of an undervoltage element by applying a digital input signal to the relay.

### **Undervoltage protection based on conventional voltage measurement**

Both the low-set and the high-set undervoltage element can independently be set to pickup and trip when one of the three voltages or all the voltages fall below the set pickup value. By default, the low-set undervoltage element operates when one of the three voltages fall below the set pickup value and the high-set undervoltage element operates when all the voltages fall below the set pickup value. The selection is made in SGF4/7 and SGF4/8.

When the phase-to-phase voltage values fall below the set pickup value of the low-set element, 27P-1, the element generates a pickup signal after a  $\sim 80$  ms' pickup time. When the set operate time at definite-time characteristic or the calculated operate time at IDMT characteristic elapses, the element generates a trip signal.

Element 27P-1 has a settable resetting time (both at definite-time and IDMT characteristics), 27P-1 RESET, for reset coordination with existing electromechanical relays or for reducing fault clearance times of recurring, transient faults. If element 27P-1 has picked up and the phase-to-phase voltages exceed the set pickup value of the element, the pickup of the element remains active for the set resetting time. If the phase-to-phase voltages fall below the set pickup value again while the timer is running, the timer is cleared and the pickup of the element remains active.

Consequently, the set resetting time ensures that when the element picks up because of voltage drops, it is not immediately reset. If element 27P-1 has already tripped, the element is reset in 70 ms after the phase-to-phase voltages have fallen below  $0.15 \times U_n$  (VT). However, if element 27P-1 has already tripped and the phase-to-phase voltages have exceeded the set pickup value of the element, the element is reset when the set resetting time has expired.

Element 27P-1 tripping can be set to be blocked by the pickup of element 27P-2 or 27D.

Element 27P-1 can also be configured to be used for alarm purposes. When a trip signal is generated for alarm purposes, the Start/Alarm target LED is lit and the fault is indicated as an alarm instead of a trip.

When element 27P-1 is configured to be used for alarm purposes:

- Pickup signal of element is not generated
- Trip signal of element is generated, but it is indicated as an alarm
- Element cannot be used for triggering CBFAIL
- Number of pickups is increased instead of number of trips

When the conventional protection mode is selected and the voltages fall below the set pickup value of the high-set element, 27P-2, the element generates a pickup signal after a  $\sim 50$  ms' pickup time. When the set operate time at definite-time characteristic or the calculated operate time at IDMT characteristic elapses, the element generates a trip signal. The element is reset in 70 ms after the phase-to-phase voltages have exceeded the set pickup value of the element.

The undervoltage elements have a settable drop-off/pick-up ratio, which is adjustable between 1.01...1.05, the default being 1.03.

### **Undervoltage protection based on positive phase-sequence voltage**

The undervoltage protection based on calculated positive phase-sequence voltage can be applied to disconnecting a smaller power plant from the outside network, for instance in situations where there is a fault in the network which can be critical for the power plant, such as a short circuit either at the transmission or distribution network level.

A situation of this kind can be critical for different reasons. The power plant can be left to feed an isolated network due to a trip caused by a fault. In this case, there is a risk that the isolated network, which is in asynchronous state compared to the rest of the network, is reconnected to the network as a result of an autoreclosure, for instance. In addition, the power plant can also fall into an asynchronous state in a fault situation. These critical situations can be prevented by disconnecting the power plant from the network fast enough by tripping the connecting circuit breaker.

The benefit of this function is that the voltage value measured during or after a network fault is a good measure of how critical the fault is for a smaller power plant. When the positive phase-sequence voltage value falls below the critical limit, the power plant has to be disconnected from the network.

REU610 measuring the positive phase-sequence voltage complements other methods used to disconnect smaller power plants. The application of these methods is based on frequency and voltage measurement. The undervoltage protection based on calculated positive phase-sequence voltage requires that the relay is in three-phase use.

When the calculated positive phase-sequence voltage value  $U_1$  falls below the set pickup value of the element 27D, the element generates a pickup signal after a  $\sim 50$  ms' pickup time. When the set operate time at definite-time characteristic or the calculated operate time at IDMT characteristic elapses, the element generates a trip signal. The element is reset in 70 ms after the calculated positive phase-sequence voltage value has exceeded the set pickup value of the element.

The positive phase-sequence voltage is calculated as follows:

$$\underline{U}_1 = \frac{\underline{U}_{ab} + a \times \underline{U}_{bc} + a^2 \times \underline{U}_{ca}}{3} \quad (2)$$

$$\begin{aligned} a &= 1 \angle 120^\circ \\ a^2 &= 1 \angle -120^\circ \end{aligned}$$

On a symmetrical network, this formula scales the positive phase-sequence value to the same amplitude as the measured voltage signal.

Element 27P-2 can be set to be blocked when the measured voltage values fall below  $0.15 \times U_n$  (VT). In addition, the tripping of element 27P-1 can be set to be blocked by element 27P-2 pickup. The selection is made in SGF4.

Element 27D has a fixed drop-off/pick-up ratio of 1.04.

#### 5.1.4.4.

#### Residual overvoltage protection

The residual overvoltage protection detects residual voltages caused by ground faults.

When the residual voltage exceeds the set pickup value of the low-set element 59N-1, the element generates a pickup signal after a  $\sim 70$  ms' pickup time. When the set operate time elapses, the element generates a trip signal.

Element 59N-1 has a settable resetting time 59N-1 RESET for reset coordination with existing electromechanical relays or for reducing fault clearance times of recurring, transient faults. If element 59N-1 has picked up and the residual voltage falls below the set pickup value of the element, the pickup of the element remains

active for the set resetting time. If the residual voltage exceeds the set pickup value again while the timer is running, the timer is cleared and the pickup of the element remains active.

Consequently, the set resetting time ensures that when the element picks up because of voltage spikes, it is not immediately reset. If element 59N-1 has already tripped, the element is reset in 50 ms after the residual voltage falls below 0.5 times the set pickup value of the element. However, if element 59N-1 has already tripped and the residual voltage has fallen below the set pickup value of the element, but not below 0.5 times the set pickup value, the element is reset after the set resetting time (59N-1 RESET) has expired.

When the residual voltage exceeds the set pickup value of the high-set element 59N-2, the element generates a pickup signal after a ~ 60 ms' pickup time. When the set operate time has elapsed, the element generates a trip signal.

If element 59N-2 has picked up and the residual voltage falls below the set pickup value of the element, the pickup of the element remains active for 100 ms. If the residual voltage exceeds the set pickup value again while the timer is running, the timer is cleared and the pickup of the element remains active. If element 59N-2 has already tripped, the element is reset in 50 ms after the residual voltage falls below 0.5 times the set pickup value of the element. However, if element 59N-2 has already tripped and the residual voltage has fallen below the set pickup value of the element, but not below 0.5 times the set pickup value, the element is reset after the 100 ms' resetting time has expired.

Elements 59N-1 can be set out of operation in SGF3/3 and element 59N-2 can be set out of operation in SGF3/4. This state is indicated by dashes on the LCD and by 999 when the set pickup value is read via serial communication.



It is possible to block the tripping of a residual overvoltage element by applying a digital input signal to the relay.

#### 5.1.4.5.

#### Circuit-breaker failure protection

The circuit-breaker failure protection (CBFAIL) detects situations where the trip remains active although the circuit breaker should have operated.

The CBFAIL unit generates a trip signal via output PO2 when the set operate time of CBFAIL expires.

The CBFAIL can be triggered internally via protection functions. All the signals, except external trip, routed to output PO1 trigger the CBFAIL. If the fault situation is not cleared when the set operate time has elapsed, the CBFAIL generates a trip signal via output PO2.

The CBFAIL can also be selected to be triggered externally by applying a digital input signal to the relay, if the maximum of all three phase-to-phase voltages is above  $0.15 \times U_n$  (VT). If the fault situation is not cleared when the set operate time has elapsed, the CBFAIL generates a trip signal via output PO2.

Internal triggering is selected by activating the CBFAIL in SGF1/6 and external triggering by activating the CBFAIL in SGB1...5/7.

Normally, the CBFAIL controls the upstream circuit breaker. However, it can also be used for tripping via redundant trip circuits of the same circuit breaker.

#### 5.1.4.6.

#### Inverse definite minimum time characteristics

Each of the overvoltage and undervoltage elements can be given either a definite-time or an inverse definite minimum time (IDMT) characteristic. The following setting parameters determine the operation mode of the overvoltage and undervoltage protection elements:

**Table 5.1.4.6.-1 Operation mode setting parameters**

Protection element	Parameter	Setting
59P-1	S3	0 = definite time 1 = curve A 2 = curve B
59P-2/47	S11	0 = definite time 1 = curve A 2 = curve B
27P-1	S15	0 = definite time 1 = curve C
27P-2/27D	S22	0 = definite time 1 = curve C

At IDMT characteristic, the operate time of the element is dependent on the voltage value: the greater the deviation from the setting value, the shorter the operate time. Three time/voltage curve groups are available: A, B and C.

An overvoltage element picks up when the measured voltage exceeds the setting value of the element. An undervoltage element picks up when the measured voltage drops below the setting value of the element. However, the IDMT calculation does not pickup until the deviation between the measured voltage and the setting value exceeds 3 percent. The operate time accuracy stated in technical data applies when the deviation is 10 percent or higher.

#### Characteristics of the overvoltage elements

The IDMT characteristic curve groups A and B are designed for overvoltage elements 59P-1 and 59P-2/47. Elements 59P-1 and 59P-2/47 can be configured to use different characteristics. The relationship between time and voltage at IDMT characteristic can be expressed as follows:

$$t[s]=\frac{TD \times 480}{\left(32 \times \frac{U - 59P}{59P} - 0.5\right)^p} + 0.05 \tag{3}$$

- t = operate time
- TD = time dial 59P-1 TD or 59P-2 TD
- U = measured voltage
- 59P = set pickup value 59P-1 or 59P-2/47
- p = constant (see Table 5.1.4.6.-2)

The A- and B-type characteristics are illustrated in Fig. 5.1.4.6.-1 and Fig. 5.1.4.6.-2.



If the ratio between the voltage and the set value is higher than 1.6, the operate time is the same as when the ratio is 1.6.

### Characteristic of the undervoltage elements

The IDMT characteristic curve group C is designed for undervoltage elements 27P-1 and 27P-2/27D. Elements 27P-1 and 27P-2/27D can be configured to use different characteristics. The relationship between time and voltage at IDMT characteristic can be expressed as follows:

$$t[s]=\frac{TD \times 480}{\left(32 \times \frac{27P - U}{27P} - 0.5\right)^p} \tag{4}$$

- t = operate time
- TD = time dial 27P-1 TD or 27P-2 TD
- U = measured voltage
- 27P = set pickup value 27P-1 or 27P-2/27D
- p = constant (see Table 5.1.4.6.-2)

The C-type characteristic is illustrated in Fig. 5.1.4.6.-3.



If the ratio between the voltage and the set value is lower than 0.3, the operate time is the same as when the ratio is 0.3.

**Table 5.1.4.6.-2 Values of constant  $p$** 

Time/voltage characteristic	A	B	C
$p$	2	3	2

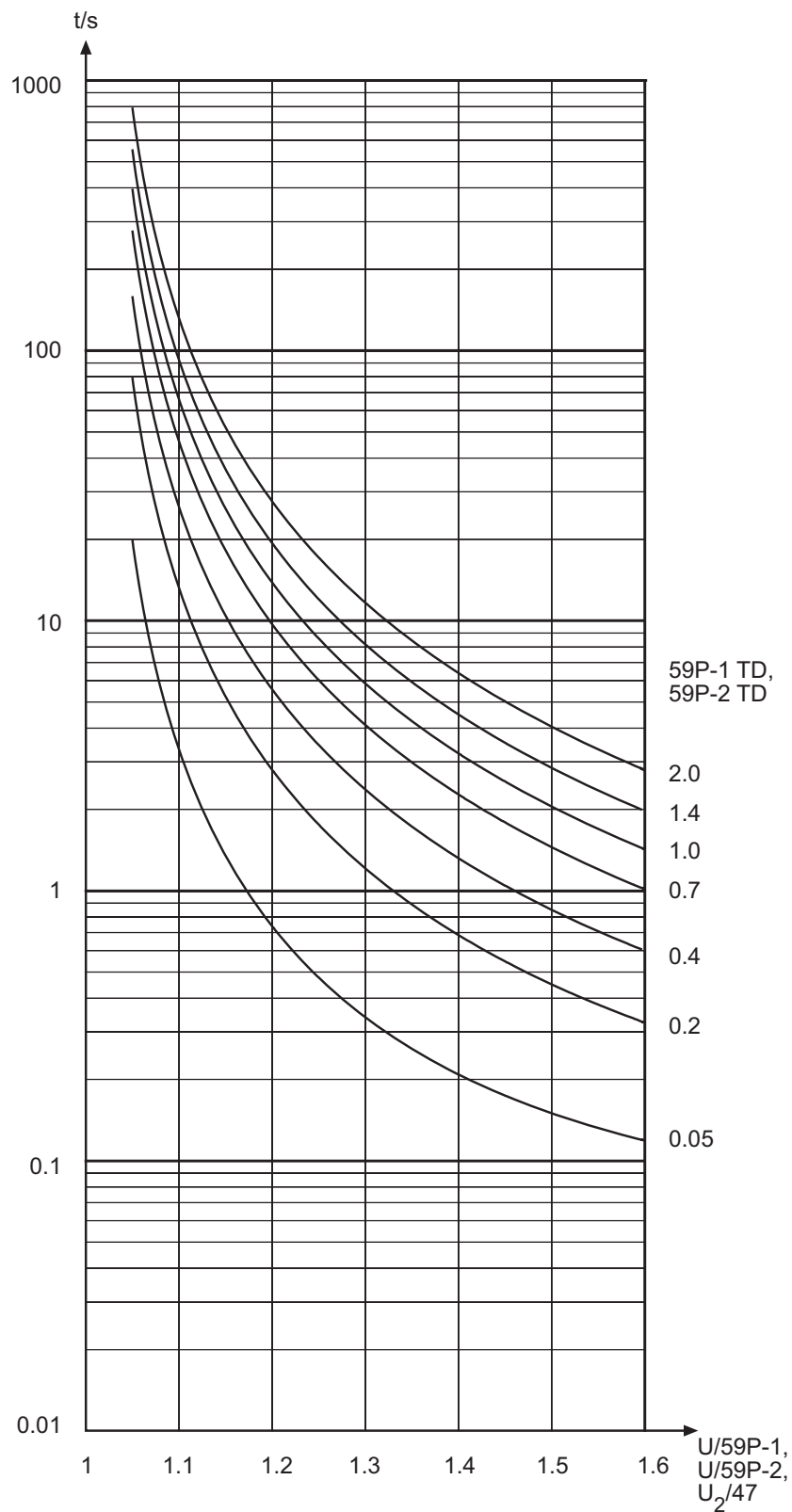

Fig. 5.1.4.6.-1 Characteristics of type A

A052085

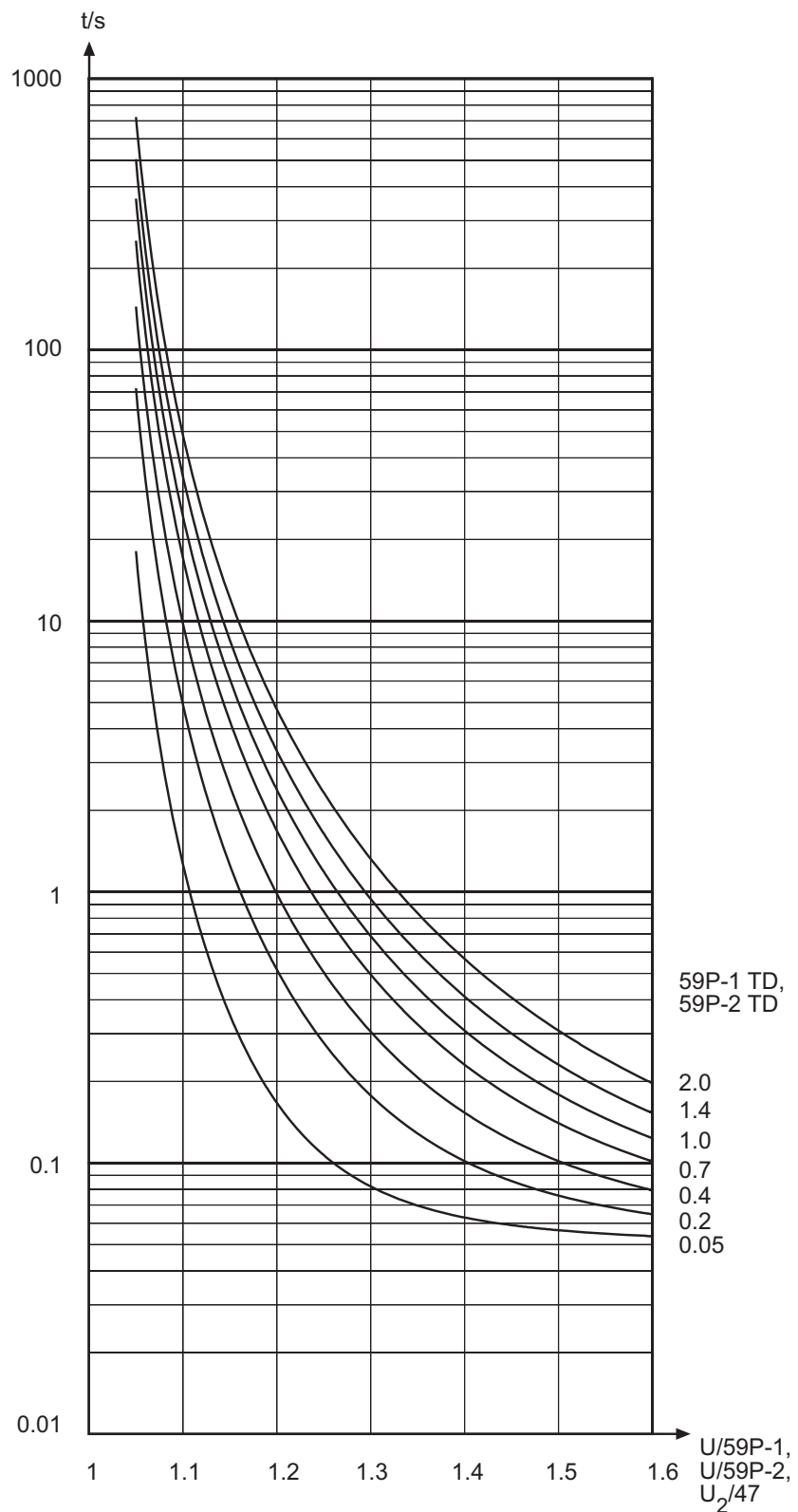

Fig. 5.1.4.6.-2 Characteristics of type B

A052087

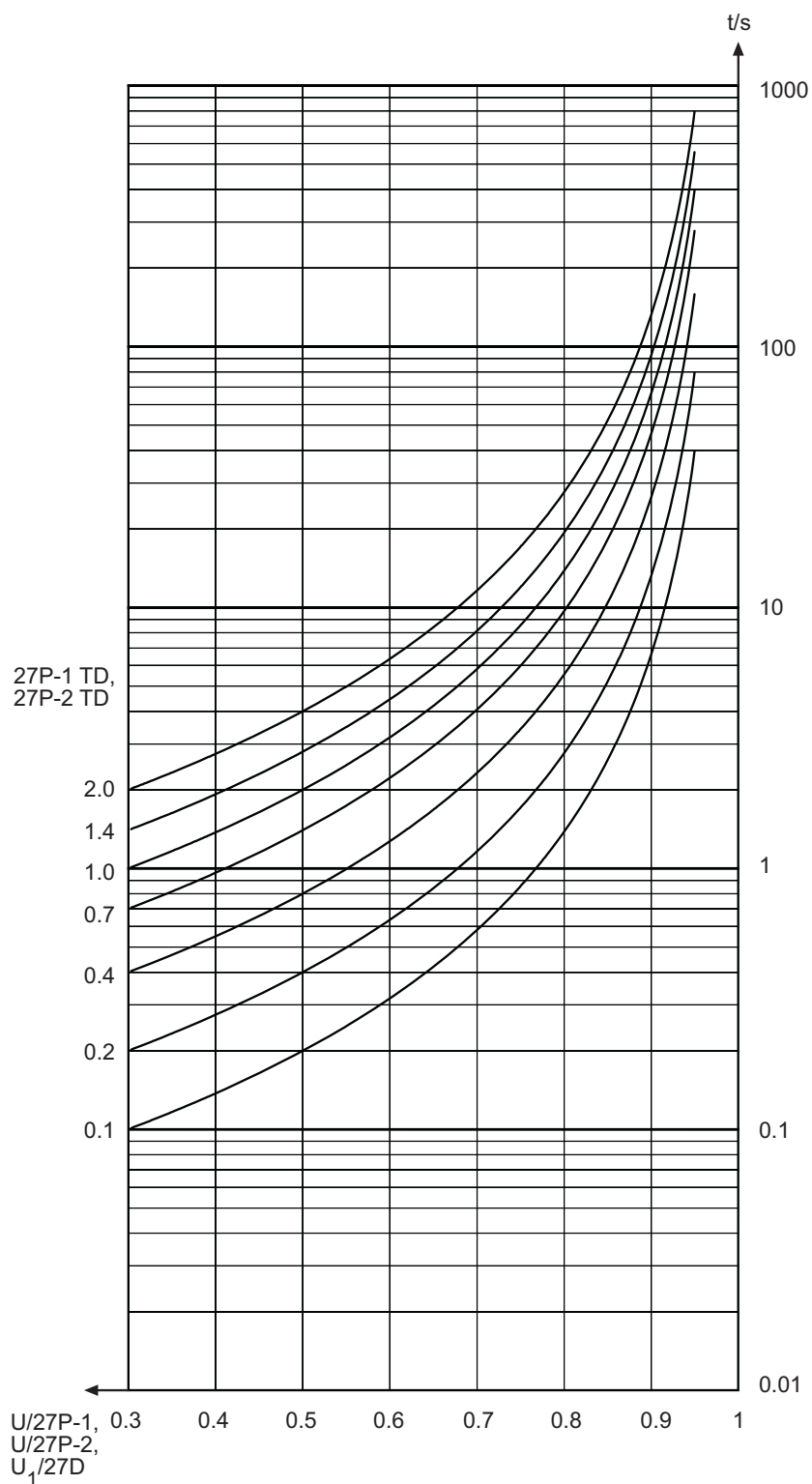

Fig. 5.1.4.6.-3 Characteristics of type C

A052089

### 5.1.4.7. Settings

There are two alternative setting groups available, setting groups 1 and 2. Either of these setting groups can be used as the actual settings, one at a time. Both groups have their related registers. By switching between the setting groups, a whole group of settings can be changed at the same time. This can be done in any of the following ways:

- Via the HMI
- Entering SPA parameter V150 via serial communication
- Via a digital input



Switching between setting groups via a digital input has a higher priority than via the HMI or with the parameter V150.

The setting values can be altered via the HMI or with a PC provided with Relay Setting Tool.

Before the relay is connected to a system it must be assured that the relay has been given the correct settings. If there is any doubt, the setting values should be read with the relay trip circuits disconnected or tested with current injection; refer to Chapter 7. Check lists for additional information.

**Table 5.1.4.7.-1 Setting values**

Setting	Description	Setting range	Default setting
59P-1	Pickup value of element 59P-1	0.60...1.40 × U <sub>n</sub> (VT)	1.2
59P-1 TDLY	Operate time of element 59P-1	0.06...600 s	0.06
59P-1 MODE	Operation mode setting for 59P-1	0 = definite time 1 = curve A 2 = curve B	0
59P-1 TD	IDMT time dial 59P-1 TD	0.05...2.00	0.05
59P-1 RSET	Resetting time of element 59P-1	0.07...60.0 s	0.07
59P-1 D/P	Drop-off/pick-up ratio of element 59P-1	0.95...0.99	0.97
U <sub>1</sub> /U <sub>2</sub> MODE	U <sub>1</sub> /U <sub>2</sub> mode setting of elements 59P-2 and 27P-2	0 = 59P-2 and 27P-2 1 = 59P-2 and 27D 2 = 47 and 27P-2	0
59P-2	Pickup value of element 59P-2	0.80...1.60 × U <sub>n</sub> (VT)	1.2
47	Pickup value of element 47	0.05...1.00 × U <sub>n</sub> (VT)	0.05
59P-2 TDLY	Operate time of element 59P-2	0.05...600 s	0.05
59P-2/U <sub>2</sub> MODE	Operation mode setting for 59P-2/U <sub>2</sub>	0 = definite time 1 = curve A 2 = curve B	0
59P-2 TD	IDMT time dial 59P-2 TD	0.05...2.00	0.05
27P-1	Pickup value of element 27P-1	0.20...1.20 × U <sub>n</sub> (VT)	0.2
27P-1 TDLY	Operate time of element 27P-1	0.10...600 s	0.1
27P-1 MODE	Operation mode setting for 27P-1	0 = definite time 1 = curve C	0
27P-1 TD	IDMT time dial 27P-1 TD	0.10...2.00	0.1

Setting	Description	Setting range	Default setting
27P-1 RSET	Resetting time of element 27P-1	0.07...60.0 s	0.07
27P-1 D/P	Drop-off/pick-up ratio of element 27P-1	1.01...1.05	1.03
27P-2	Pickup value of element 27P-2	0.20...1.20 × U <sub>n</sub> (VT)	0.2
27D	Pickup value of element 27D	0.20...1.20 × U <sub>n</sub> (VT)	0.3
27P-2 TDLY	Operate time of element 27P-2	0.10...600 s	0.1
27P-2/U <sub>1</sub> MODE	Operation mode setting for 27P-2/U <sub>1</sub>	0 = definite time 1 = curve C	0
27P-2 TD	IDMT time dial 27P-2 TD	0.10...2.00	0.1
59N-1	Pickup value of element 59N-1	2.0...80.0% U <sub>n</sub> (VT)	2.0
59N-1 TDLY	Operate time of element 59N-1	0.10...600 s	0.1
59N-1 RSET	Resetting time of element 59N-1	0.07...60.0 s	0.07
59N-2	Pickup value of element 59N-2	2.0...80.0% U <sub>n</sub> (VT)	2.0
59N-2 TDLY	Operate time of element 59N-2	0.10...600 s	0.1
Trip fail	Operate time of CBFAIL	0.10...60.0 s	0.10

### Switchgroups and parameter masks

The settings can be altered and the functions of the relay selected in the SG\_ selector switchgroups. The switchgroups are software based and thus not physical switches to be found in the hardware of the relay.

A checksum is used for verifying that the switches have been properly set. The Fig. 5.1.4.7.-1 shows an example of manual checksum calculation.

Switch number	Position		Weighting factor		Value
1	1	x	1	=	1
2	0	x	2	=	0
3	1	x	4	=	4
4	0	x	8	=	0
5	1	x	16	=	16
6	0	x	32	=	0
7	1	x	64	=	64
8	0	x	128	=	0
9	1	x	256	=	256
10	0	x	512	=	0
11	1	x	1024	=	1024
12	0	x	2048	=	0
13	1	x	4096	=	4096
14	0	x	8192	=	0
15	1	x	16384	=	16384
16	0	x	32768	=	0
17	1	x	65536	=	65536
18	0	x	131072	=	0
19	1	x	262144	=	262144
20	0	x	524288	=	0
21	1	x	1048576	=	1048576
22	0	x	2097152	=	0
23	1	x	4194304	=	4194304
checksum			SG_Σ	=	5505024

A051892

Fig. 5.1.4.7.-1 Example of calculating the checksum of a SG\_selector switchgroup

When the checksum, calculated according to the example above, equals the checksum of the switchgroup, the switches in the switchgroup are properly set.

The factory default settings of the switches and the corresponding checksums are presented in the following tables.

### SGF1...SGF5

Switchgroups SGF1...SGF5 are used for configuring the wanted function as follows:

**Table 5.1.4.7.-2 SGF1**

Switch	Function	Default setting
SGF1/1	Selection of the latching feature for PO1	0
SGF1/2	Selection of the latching feature for PO2	0
SGF1/3	Selection of the latching feature for PO3 <ul style="list-style-type: none"> <li>When the switch is in position 0 and the measuring signal which caused the trip falls below the set pickup value, the output contact returns to its initial state.</li> <li>When the switch is in position 1, the output contact remains active although the measuring signal which caused the trip falls below the set pickup value.</li> </ul> <p>A latched output contact can be unlatched either via the HMI, a digital input or the serial bus.</p>	0
SGF1/4	Minimum pulse length for SO1 and SO2 and optional SO3, SO4 and SO5 <ul style="list-style-type: none"> <li>0 = 80 ms</li> <li>1 = 40 ms</li> </ul>	0
SGF1/5	Minimum pulse length for PO1, PO2 and PO3 <ul style="list-style-type: none"> <li>0 = 80 ms</li> <li>1 = 40 ms</li> </ul> <div style="display: flex; align-items: center;">  <p>The latching feature being selected for PO1, PO2 and PO3 overrides this function.</p> </div>	0
SGF1/6	CBFAIL <ul style="list-style-type: none"> <li>0 = CBFAIL is not in use</li> <li>1 = the signal to PO1 pickups a timer which generates a delayed signal to PO2, provided that the fault is not cleared before the CBFAIL operate time has elapsed</li> </ul>	0
SGF1/7	Trip lockout function <ul style="list-style-type: none"> <li>0 = the trip lockout function is not in use. PO3 works as a normal power output relay.</li> <li>1 = the trip lockout function is in use. PO3 is dedicated to this function.</li> </ul>	0
SGF1/8	External fault warning <ul style="list-style-type: none"> <li>When the switch is in position 1, the warning signal from the trip-circuit supervision is routed to SO2.</li> </ul>	0
ΣSGF1		0

**Table 5.1.4.7.-3 SGF2**

Switch	Function	Default setting
SGF2/1	Operation mode of the pickup target of element 59P-1 <sup>a)</sup>	0
SGF2/2	Operation mode of the trip target of element 59P-1	1
SGF2/3	Operation mode of the pickup target of element 59P-2 or 47 <sup>a)</sup>	0
SGF2/4	Operation mode of the trip target of element 59P-2 or 47	1
SGF2/5	Operation mode of the pickup target of element 27P-1 <sup>a)</sup>	0
SGF2/6	Operation mode of the trip target of element 27P-1	1
SGF2/7	Operation mode of the pickup target of element 27P-2 or 27D <sup>a)</sup>	0
SGF2/8	Operation mode of the trip target of element 27P-2 or 27D	1
SGF2/9	Operation mode of the pickup target of element 59N-1 <sup>a)</sup>	0
SGF2/10	Operation mode of the trip target of element 59N-1	1
SGF2/11	Operation mode of the pickup target of element 59N-2 <sup>a)</sup>	0
SGF2/12	Operation mode of the trip target of element 59N-2 <ul style="list-style-type: none"> <li>0 = the trip target is automatically cleared after the fault has disappeared.</li> <li>1 = latching. The trip target remains active although the fault has disappeared.</li> </ul>	1
ΣSGF2		2730



Switch	Function	Default setting
--------	----------	-----------------

<sup>a)</sup> When the switch is on, the phase(s) that caused the pickup are shown on LCD.

**Table 5.1.4.7.-4 SGF3**

Switch	Function	Default setting
SGF3/1	Disabling of element 59P-2 or 47	0
SGF3/2	Disabling of element 27P-2 or 27D	0
SGF3/3	Disabling of element 59N-1	0
SGF3/4	Disable of element 59N-2 <ul style="list-style-type: none"> <li>When the switch is in position 1, the element is disabled.</li> </ul>	0
ΣSGF3		0

**Table 5.1.4.7.-5 SGF4**

Switch	Function	Default setting
SGF4/1	<p>Selecting single-phase or three-phase use</p> <ul style="list-style-type: none"> <li>0 = three-phase use</li> <li>1 = single-phase use <sup>a)</sup></li> </ul> <div style="display: flex; align-items: center;">  <p>When single-phase use is selected, the measured voltage has to be connected to inputs X2.1-1 and X2.1-2. Additionally, the <math>U_1/U_2</math> mode setting <math>S7</math> is overridden and the negative phase-sequence protection mode and positive phase-sequence protection mode are not in use.</p> </div>	0
SGF4/2	<p>Internal blocking of pickup and trip of element 27P-1 when one of the measured phase-to-phase voltages fall below <math>0.15 \times U_n</math> (VT).</p> <ul style="list-style-type: none"> <li>0 = internal blocking of pickup and trip of element 27P-1</li> <li>1 = no internal blocking of pickup and trip of element 27P-1</li> </ul>	0
SGF4/3	<p>Internal blocking of pickup and trip of element 27P-2 or 27D when one of the measured phase-to-phase voltages falls below <math>0.15 \times U_n</math> (VT)</p> <ul style="list-style-type: none"> <li>0 = internal blocking of pickup and trip of element 27P-2 or 27D</li> <li>1 = no internal blocking of pickup and trip of element 27P-2 or 27D</li> </ul>	0
SGF4/4	<p>Blocking of element 27P-1 tripping by the pickup of element 27P-2 or 27D</p> <ul style="list-style-type: none"> <li>0 = tripping of element 27P-1 is not blocked</li> <li>1 = tripping of element 27P-1 is blocked</li> </ul>	0
SGF4/5	<p>Pickup and trip criteria for element 59P-1<sup>a)</sup></p> <ul style="list-style-type: none"> <li>0 = element operates when one of the phase-to-phase voltages rise above the set pickup value.</li> <li>1 = element operates when all the phase-to-phase voltages rise above the set pickup value</li> </ul>	0
SGF4/6	<p>Pickup and trip criteria for element 59P-2<sup>a)</sup></p> <ul style="list-style-type: none"> <li>0 = element operates when one of the phase-to-phase voltages rise above the set pickup value.</li> <li>1 = element operates when all the phase-to-phase voltages rise above the set pickup value.</li> </ul> <div style="display: flex; align-items: center;">  <p>This switch has no effect if the element 59P-2 is based on negative phase-sequence calculation.</p> </div>	0
SGF4/7	<p>Pickup and trip criteria for element 27P-1<sup>a)</sup></p> <ul style="list-style-type: none"> <li>0 = element operates when one of the phase-to-phase voltages falls below the set pickup value.</li> <li>1 = element operates when all the phase-to-phase voltages fall below the set value.</li> </ul>	0

Switch	Function	Default setting
SGF4/8	<p>Pickup and trip criteria for element 27P-2<sup>a)</sup></p> <ul style="list-style-type: none"> <li>• 0 = element operates when one of the phase-to-phase voltages falls below the set pickup value.</li> <li>• 1 = element operates when all the phase-to-phase voltages fall below the set value.</li> </ul>  <p>This switch has no effect if element 27P-2 is based on positive-phase-sequence calculation.</p>	1
SGF4/9	<p>27P-1 Alarm mode selection</p> <ul style="list-style-type: none"> <li>• 0 = normal operation of element 27P-1, used for tripping purposes</li> <li>• 1 = element 27P-1 operates as 27P-1 Alarm.</li> </ul> <p>The alarm signal is routed to element 27P-1 trip in relay matrix, and the pickup signal of element 27P-1 is disabled. When the alarm signal is active, the pickup LED is lit.</p>	0
SGF4/10	<p>Internal blocking of pickup and trip of element 47 when one of the measured phase-to-phase voltages falls below <math>0.15 \times U_n</math> (VT).</p> <ul style="list-style-type: none"> <li>• 0 = internal blocking of pickup and trip of element 47</li> <li>• 1 = no internal blocking of pickup and trip of element 47</li> </ul>	0
ΣSGF4		128

<sup>a)</sup> If the switch SGF4/1 is set to 1, the switches SGF4/5...8 are overridden. Thereby all the elements use only phaseU<sub>ab</sub> as input, and other phases are not checked or used.

**Table 5.1.4.7-6 SGF5**

Switch	Function	Default setting
SGF5/1	Selection of the latching feature for programmable LED1	0
SGF5/2	Selection of the latching feature for programmable LED2	0
SGF5/3	Selection of the latching feature for programmable LED3	0
SGF5/4	Selection of the latching feature for programmable LED4	0
SGF5/5	Selection of the latching feature for programmable LED5	0
SGF5/6	Selection of the latching feature for programmable LED6	0
SGF5/7	Selection of the latching feature for programmable LED7	0
SGF5/8	<p>Selection of the latching feature for programmable LED8</p> <ul style="list-style-type: none"> <li>• When the switch is in position 0 and the signal routed to the LED is reset, the programmable LED is cleared.</li> <li>• When the switch is in position 1, the programmable LED remains lit although the signal routed to the LED is reset.</li> </ul> <p>A latched programmable LED can be cleared either via the HMI, a digital input or the serial bus.</p>	0
ΣSGF5		0

**SGB1...SGB5**

The DI1 signal is routed to the functions below with the switches of switchgroup SGB1, the DI2 signal with those of SGB2, and so forth.

**Table 5.1.4.7.-7 SGB1...SGB5**

Switch	Function	Default setting
SGB1...5/1	<ul style="list-style-type: none"> <li>• 0 = targets are not cleared by the digital input signal</li> <li>• 1 = targets are cleared by the digital input signal</li> </ul>	0
SGB1...5/2	<ul style="list-style-type: none"> <li>• 0 = targets are not cleared and latched output contacts are not unlatched by the digital input signal</li> <li>• 1 = targets are cleared and latched output contacts are unlatched by the digital input signal</li> </ul>	0
SGB1...5/3	<ul style="list-style-type: none"> <li>• 0 = targets and memorized values are not cleared and latched output contacts are not unlatched by the digital input signal</li> <li>• 1 = targets and memorized values are cleared and latched output contacts are unlatched by the digital input signal</li> </ul>	0
SGB1...5/4	Switching between setting groups 1 and 2 by using the digital input <ul style="list-style-type: none"> <li>• 0 = the setting group cannot be changed using the digital input</li> <li>• 1 = the setting group is changed by using the digital input. When the digital input is energized, setting group 2 is activated, if not, setting group 1 is activated.</li> </ul> <div style="display: flex; align-items: center; margin-top: 10px;">  <p>When SGB1...5/4 is set to 1, it is important that the switch has the same setting in both setting groups.</p> </div>	0
SGB1...5/5	Time synchronization by the digital input signal	0
SGB1...5/6	External tripping by the digital input signal	0
SGB1...5/7	External triggering of the CBFAIL by the digital input signal	0
SGB1...5/8	External triggering of the trip lockout by the digital input signal	0
SGB1...5/9	Resetting of the trip lockout by the digital input signal	0
SGB1...5/10	Blocking of tripping of element 59P-1 by the digital input signal	0
SGB1...5/11	Blocking of tripping of element 59P-2 or 47 by the digital input signal	0
SGB1...5/12	Blocking of tripping of element 27P-1 by the digital input signal	0
SGB1...5/13	Blocking of tripping of element 27P-2 or 27D by the digital input signal	0
SGB1...5/14	Blocking of tripping of element 59N-1 by the digital input signal	0
SGB1...5/15	Blocking of tripping of element 59N-2 by the digital input signal	0
ΣSGB1...5		0

**SGR1...SGR8**

The pickup, trip and alarm signals from the protection elements and the external trip signal are routed to the output contacts with the switches of switchgroups SGR1...SGR8.

The signals are routed to PO1...PO3 with the switches of switchgroup SGR1...SGR3 and to SO1...SO5 with those of SGR4...SGR8.

The matrix below can be of help when making the wanted selections. The pickup, trip and alarm signals from the protection elements, the signals from the auto-reclose function and the external trip signal are combined with the output contacts by encircling the wanted intersection point. Each intersection point is marked with a switch number, and the corresponding weighting factor of the switch is shown to the right in the matrix. The switchgroup checksum is obtained by vertically adding the weighting factors of all the selected switches of the switchgroup.



The trip lockout signal is always routed to PO3.



The trip signal from CBFAIL is always routed to PO2.



The external fault warning is always routed to SO2.

		PO1	PO2	PO3	SO1	SO2	SO3	SO4	SO5	Weighting factor
SGR1...8/1	59P-1	1	1	1	1	1	1	1	1	1
SGR1...8/2	59P-1 TDLY	2	2	2	2	2	2	2	2	2
SGR1...8/3	59P-2/47	3	3	3	3	3	3	3	3	4
SGR1...8/4	59P-2 TDLY	4	4	4	4	4	4	4	4	8
SGR1...8/5 <sup>a</sup>	27P-1	5	5	5	5	5	5	5	5	16
SGR1...8/6 <sup>a</sup>	27P-1 TDLY	6	6	6	6	6	6	6	6	32
SGR1...8/7	27P-2/27D	7	7	7	7	7	7	7	7	64
SGR1...8/8	27P-2 TDLY	8	8	8	8	8	8	8	8	128
SGR1...8/9	59N-1	9	9	9	9	9	9	9	9	256
SGR1...8/10	59N-1 TDLY	10	10	10	10	10	10	10	10	512
SGR1...8/11	59N-2	11	11	11	11	11	11	11	11	1024
SGR1...8/12	59N-2 TDLY	12	12	12	12	12	12	12	12	2048
SGR1...8/13	Ext. Trip	13	13	13	13	13	13	13	13	4096
	Checksum	ΣSGR1	ΣSGR2	ΣSGR3	ΣSGR4	ΣSGR5	ΣSGR6	ΣSGR7	ΣSGR8	

Fig. 5.1.4.7.-2 Output signal matrix

a) When element 27P-1 is used for alarm purposes (SGF4/9 = 1), only trip is generated.

A051862

**Table 5.1.4.7.-8 SGR1...SGR8**

Switch	Function	Default setting		
		SGR1...SGR3	SGR4...SGR5	SGR6...SGR8 <sup>a)</sup>
SGR1...8/1	Pickup signal from element 59P-1	0	1	0
SGR1...8/2	Trip signal from element 59P-1	1	0	0
SGR1...8/3	Pickup signal from element 59P-2 or 47	0	1	0
SGR1...8/4	Trip signal from element 59P-2 or 47	1	0	0
SGR1...8/5	Pickup signal from element 27P-1	0	1	0
SGR1...8/6	Trip signal from element 27P-1	1	0	0
SGR1...8/7	Pickup signal from element 27P-2 or 27D	0	1	0
SGR1...8/8	Trip signal from element 27P-2 or 27D	1	0	0
SGR1...8/9	Pickup signal from element 59N-1	0	1	0
SGR1...8/10	Trip signal from element 59N-1	1	0	0
SGR1...8/11	Pickup signal from element 59N-2	0	1	0
SGR1...8/12	Trip signal from element 59N-2	1	0	0
SGR1...8/13	External trip signal	0	0	0
ΣSGR1...8		2730	1365	0

<sup>a)</sup> If the optional I/O module has not been installed, dashes are shown on the LCD and "9999" when the parameter is read via the SPA bus.

### SGL1...SGL8

The signals are routed to LED1 with the switches of switchgroup SGL1, to LED2 with those of SGL2, and so forth.

**Table 5.1.4.7.-9 SGL1...SGL8**

Switch	Function	Default setting
SGL1...8/1	Trip signal from element 59P-1	0
SGL1...8/2	Trip signal from element 59P-2 or 47	0
SGL1...8/3	Trip signal from element 27P-1	0
SGL1...8/4	Trip signal from element 27P-2 or 27D	0
SGL1...8/5	Trip signal from element 59N-1	0
SGL1...8/6	Trip signal from element 59N-2	0
SGL1...8/7	Trip lockout signal	0
SGL1...8/8	DI1 signal	0
SGL1...8/9	DI2 signal	0
SGL1...8/10	DI3 signal	0
SGL1...8/11	DI4 signal	0
SGL1...8/12	DI5 signal	0
SGL1...8/13	CB Fail trip	0
SGL1...8/14	DR triggered	0
ΣSGL1...SGL8		0

### New trip target timer

The new trip target timer can be configured to allow a second trip target on the LCD. When several protection elements trip, the first trip target is displayed until the time, as specified by the NEW TRIP IND. setting value, has expired. After this, a new trip target can displace the old one. The basic protection functions are not affected by the NEW TRIP IND. setting.

**Table 5.1.4.7.-10 New trip target timer**

Setting	Description	Setting range	Default setting
New trip target	New trip target timer in minutes	0...998	60
	No new trip target allowed until the previous one has been manually cleared.	999	-

### Non-volatile memory settings



Non-volatile memory is backed up by a battery; the battery must be inserted and charged.

The table below presents data which can be configured to be stored in the non-volatile memory. All of the functions mentioned below can be selected separately with switches 1...5 either via the HMI or the SPA bus.

**Table 5.1.4.7.-11 Memory settings**

Setting	Switch	Function	Default setting
Non-volatile memory settings	1	<ul style="list-style-type: none"> <li>0 = operation target messages and LEDs are cleared</li> <li>1 = operation target messages and LEDs are retained</li> </ul>	1
	2	<ul style="list-style-type: none"> <li>1 = disturbance recorder data is retained <sup>a)</sup></li> </ul>	1
	3	<ul style="list-style-type: none"> <li>1 = event codes are retained<sup>a)</sup></li> </ul>	1
	4	<ul style="list-style-type: none"> <li>1 = recorded data and information on the number of pickups of the protection elements are retained</li> </ul>	1
	5	<ul style="list-style-type: none"> <li>1 = the real-time clock is running also during loss of auxiliary voltage<sup>a)</sup></li> </ul>	1
	Σ		31

<sup>a)</sup> The prerequisite is that the battery has been inserted and is charged.



When all switches are set to zero, the battery supervision is disabled.

## 5.1.4.8.

## Technical data on protection functions

Table 5.1.4.8.-1 Overvoltage protection, elements 59P-1, 59P-2 and 47

Feature	Element 59P-1	Element 59P-2	Element 47
Set pickup value 59P-1, 59P-2 and 47:			
-at definite-time characteristic	$0.60...1.40 \times U_n$ (VT)	$0.80...1.60 \times U_n$ (VT)	$0.05...1.00 \times U_n$ (VT)
-at IDMT characteristic	$0.60...1.25 \times U_n$ (VT) <sup>a)</sup>	$0.80...1.25 \times U_n$ (VT) <sup>a)</sup>	$0.05...1.00 \times U_n$ (VT)
Pickup time, typical	60 ms	50 ms	50 ms
Time/voltage characteristic:			
-definite-time operate time, 59P-1 TDLY, 59P-2 TDLY	0.06...600 s	0.05...600 s	0.05...600 s
-IDMT	curve A curve B	curve A curve B	curve A curve B
time dial, 59P-1 TD, 59P-2 TD	0.05...2.00	0.05...2.00	0.05...2.00
Resetting time, typical/maximum	70/80 ms <sup>b)</sup>	70/80 ms	70/80 ms
Retardation time, typical	30 ms	30 ms	50 ms
Set resetting time, 59P-1 RESET	0.07...60.0	-	-
Drop-off/pick-up ratio, 59P-1 D/P	0.95...0.99	0.95...0.99	0.96
Operate time accuracy:			
-at definite-time characteristic	±2% of the set operate time or ±25 ms	±2% of the set operate time or ±25 ms	±2% of the set operate time or ±25 ms
-at IDMT characteristic	±25 ms + the accuracy appearing when the measured voltage varies ±3%	±25 ms + the accuracy appearing when the measured voltage varies ±3%	±25 ms + the accuracy appearing when the measured voltage varies ±3%
Operation accuracy	±1.5% of the set pickup value	±1.5% of the set pickup value	-
$-0.05...0.15 \times U_n$ (VT)	-	-	±10% of the set pickup value
$-0.15...1.00 \times U_n$ (VT)	-	-	±5% of the set pickup value

a) Because of the maximum measured voltage ( $2 \times U_n$  (VT)), the setting value 1.25 is used for the IDMT calculation if the set value is greater than 1.25. This makes the operate time faster than the theoretical IDMT curve. However, the element always picks up according to the set value.

b) Resetting time of the trip signal.

Table 5.1.4.8.-2 Undervoltage protection, elements 27P-1, 27P-2 and 27D

Feature	Element 27P-1	Element 27P-2	Element 27D
Set pickup value 27P-1, 27P-2 and 27D:			
-at definite-time characteristic	$0.20...1.20 \times U_n$ (VT)	$0.20...1.20 \times U_n$ (VT)	$0.20...1.20 \times U_n$ (VT)
-at IDMT characteristic	$0.20...1.20 \times U_n$ (VT)	$0.20...1.20 \times U_n$ (VT)	$0.20...1.20 \times U_n$ (VT)
Pickup time, typical	80 ms	50 ms	50 ms

Technical Reference Manual - ANSI Version

Feature	Element 27P-1	Element 27P-2	Element 27D
Time/voltage characteristic: -at definite operate time, 27P-1 TDLY and 27P-2 TDLY -IDMT time dial 27P-1 TD and 27P-2 TD	0.10...600 s  curve C 0.10...2.00	0.10...600 s  curve C 0.10...2.00	0.10...600 s  curve C 0.10...2.00
Resetting time, typical/maximum	70/80 ms <sup>a)</sup>	70/80 ms	70/80 ms
Retardation time, typical	30 ms	30 ms	50 ms
Set resetting time, 27P-1 RESET	0.07...60.0 s	-	-
Drop-off/pick-up ratio, 27P-1 D/P	1.01...1.05	1.01...1.05	1.04
Operate time accuracy: -at definite-time characteristic  -at IDMT characteristic	$\pm 2\%$ of the set operate time or $\pm 25$ ms  $\pm 25$ ms + the accuracy appearing when the measured voltage varies $\pm 3\%$	$\pm 2\%$ of the set operate time or $\pm 25$ ms  $\pm 25$ ms + the accuracy appearing when the measured voltage varies $\pm 3\%$	$\pm 2\%$ of the set operate time or $\pm 25$ ms  $\pm 25$ ms + the accuracy appearing when the measured voltage varies $\pm 3\%$
Operation accuracy	$\pm 1.5\%$ of the set pickup value	$\pm 1.5\%$ of the set pickup value	$\pm 5\%$ of the set pickup value

<sup>a)</sup> Resetting time of the trip signal.

**Table 5.1.4.8.-3 Residual overvoltage protection, elements 59N-1 and 59N-2**

Feature	Element 59N-1	Element 59N-2
Set pickup value 59N-1 and 59N-2: -at definite-time characteristic	2.0...80% $U_n$ (VT)	2.0...80% $U_n$ (VT)
Pickup time, typical	70 ms	60 ms
Time/voltage characteristic: -definite-time operate time, 59N-1 TDLY, 59N-2 TDLY	0.10...600 s	0.10...600 s
Resetting time, typical/maximum	30/50 ms <sup>a)</sup>	30/50 ms <sup>a)</sup>
Retardation time, typical	30 ms	30 ms
Set resetting time, 59N-1 RESET	0.07...60.0 s	100 ms
Drop-off/pick-up ratio, typical	0.96	0.96
Operate time accuracy: -at definite-time characteristic	$\pm 2\%$ of the set operate time or $\pm 25$ ms	$\pm 2\%$ of the set operate time or $\pm 25$ ms
Operation accuracy	$\pm 1.5\%$ of the set pickup value or $\pm 0.05\% U_n$ (VT)	$\pm 1.5\%$ of the set pickup value or $\pm 0.05\% U_n$ (VT)

<sup>a)</sup> Resetting time of the trip signal.

**Table 5.1.4.8.-4      CBFAIL**

Feature	Value
Set operate time	0.10...60.0 s
Phase-to-phase voltage threshold for external triggering of the CBFAIL: -pick-up/drop-off	0.15/0.10 × U <sub>n</sub> (VT)

**5.1.5.****Trip-circuit supervision**

The trip-circuit supervision (TCS) detects open circuits, both when the circuit breaker is open and closed, and trip-circuit supply failure.

The trip-circuit supervision is based on a constant current injection principle: by applying operating voltage for the circuit breaker, a constant current is forced to flow through the external trip circuit. If the resistance of the trip circuit exceeds a certain limit, due to oxidation or a bad contact, for instance, the trip-circuit supervision is activated and a warning appears on the LCD together with a fault code. The warning signal from the trip-circuit supervision can also be routed to SO2 by setting switch SGF1/8 to 1.

Under normal operating conditions, the applied external voltage is divided between the relay's internal circuit and the external trip circuit so that at least 20 V remains over the relay's internal circuit. If the external trip circuit's resistance is too high or the internal circuit's too low, due to welded relay contacts, for instance, the voltage over the relay's internal circuit falls below 20 V (15...20 V), which activates the trip-circuit supervision.

The operation condition is:

$$U_c - (R_{ext} + R_{int} + R_s) \times I_{tc} \geq 20 \text{ V AC/DC} \quad (5)$$

$U_c$  = operating voltage over the supervised trip circuit  
 $I_{tc}$  = current flowing through the trip circuit, ~1.5 mA  
 $R_{ext}$  = external shunt resistor  
 $R_{int}$  = internal shunt resistor, 1 kΩ  
 $R_s$  = trip coil resistance

The external shunt resistor is used to enable trip-circuit supervision also when the circuit breaker is open.

The resistance of the external shunt resistor is to be calculated so that it does not cause malfunction of the trip-circuit supervision or affect the operation of the trip coil. Too high resistance causes too high voltage drop, which in turn results in the operation conditions not being fulfilled, whereas too low resistance may cause faulty operation of the trip coil.

The following values are recommended for the external resistor,  $R_{ext}$ :

**Table 5.1.5.-1 Recommended values for  $R_{ext}$**

Operating voltage, $U_c$	Shunt resistor $R_{ext}$
48 V DC	1.2 k $\Omega$ , 5 W
60 V DC	5.6 k $\Omega$ , 5 W
110 V DC	22 k $\Omega$ , 5 W
220 V DC	33 k $\Omega$ , 5 W

The circuit breaker is to be provided with two external contacts, one opening and one closing contact. The closing contact is to be connected in parallel with the external shunt resistor, which enables trip-circuit supervision when the circuit breaker is closed. The opening contact, on the contrary, is to be connected in series with the external shunt resistor, which enables trip-circuit supervision when the circuit breaker is open; see Fig. 5.1.5.-1.

Trip-circuit supervision can be selected either via the HMI or with SPA parameter V113.

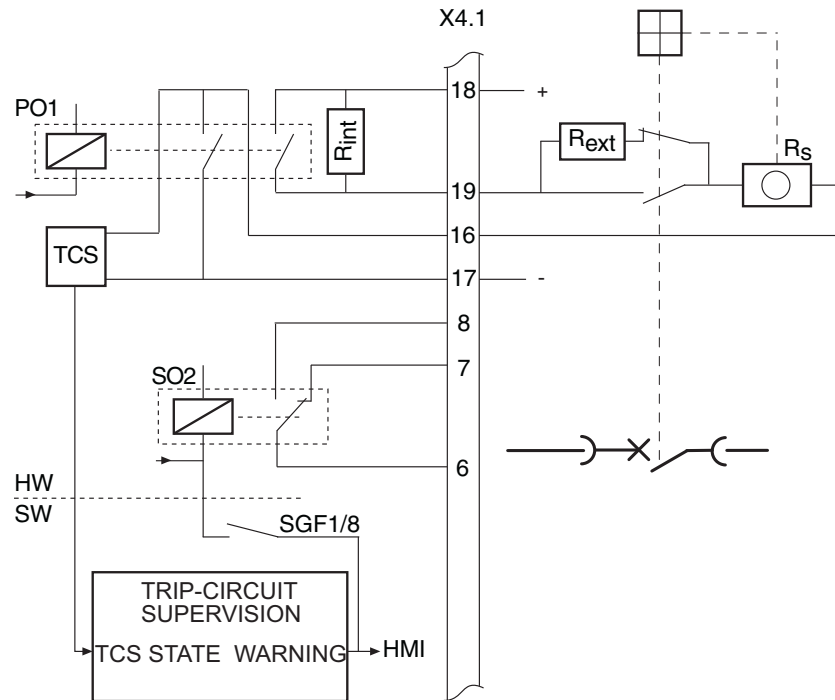

A040329\_2

*Fig. 5.1.5.-1 Connecting the trip-circuit supervision using two external contacts and the external resistor in the trip circuit*

**5.1.6. Trip lockout function**

The trip lockout function is used to prevent accidental closing of the circuit breaker after a trip. The trip lockout function must be locally reset with a separate reset command before the circuit breaker can be closed again. This function is useful when the trip output contact of the relay is latched or the open circuit of the circuit breaker remains activated.

The trip lockout function is selected in SGF1. When selected, PO3 is dedicated to this function. As long as no trip occurs, PO3 is closed.

Every signal which has been routed to PO3 via the output signal matrix activates the trip lockout function and opens the contacts of PO3. When the contacts have opened, they are locked into the open state.

The trip lockout function can also be activated externally, via a digital input. The trip lockout function can be reset via a digital input, the HMI or SPA parameter V103, but not before the signal which activated the function has been reset.

In case of loss of auxiliary power when the trip lockout function is in use, the contacts of PO3 return to the same state as before the loss, provided that the battery has been inserted and is charged. If no battery has been inserted, the trip lockout function is activated and the contacts of PO3 remain open when the auxiliary power is switched on again.

### 5.1.7. Trip counters for circuit-breaker condition monitoring

The trip counters for circuit-breaker condition monitoring provide history data, which can be used for circuit-breaker service scheduling. With this information, the service cycle can be estimated for the future.

The monitoring function consists of four counters, which count the number of trip signals generated to the circuit breaker by the relay. Every time an element generates a trip signal, the corresponding counter value is increased by one. The number of trips is stored in the non-volatile EEPROM memory.

There are separate counters for the different protection elements. The overvoltage elements (59P-1, 59P-2 and 47), undervoltage elements (27P-1, 27P-2 and 27D) and residual overvoltage elements (59N-1 and 59N-2) have a common trip counter each, whereas there is an own trip counter for the external trip.

The counters can be read via the HMI or SPA parameters V9...V12 and cleared via SPA parameter V166. When a counter reaches its maximum value, it rolls over.



In case several elements trip during the same fault sequence, only the counter of the element which tripped first is increased by one.

### 5.1.8. Target LEDs and operation target messages

The operation of the relay can be monitored via the HMI by means of LED targets and text messages on the LCD. On the front panel of the relay there are three target LEDs with fixed functionality:

- Green target LED (ready)
- Yellow target LED (pickup/alarm)
- Red target LED (trip)

In addition, there are eight programmable LEDs and an target LED for front communication. Refer to the Operator's Manual for a more thorough presentation.

The target messages on the LCD have a certain priority order. If different types of targets are activated simultaneously, the message with the highest priority appears on the LCD.

The priority order of the operation target messages:

1. CBFAIL
2. Trip
3. Pickup/Alarm

### 5.1.9. Demand values

The relay provides three different kinds of demand values.

The first value shows the average voltage of all three phase-to-phase voltages measured during one minute. The value is updated once a minute.

The second value shows the average voltage during an adjustable time range, ranging from 0 to 999 minutes, with an accuracy of one minute. This value is updated at the expiration of each time range.

The third value shows the highest one-minute average voltage value measured during the previous time range. However, if the time range is set to zero, only the one-minute and the maximum average voltage value is shown. The maximum value is the highest one-minute mean value since the last reset.

The demand voltage values can be set to zero through serial communication using SPA parameter V102. The average voltage values are also reset if SPA parameter V105 is changed or the relay is reset.

### 5.1.10. Commissioning tests

The following two product functions can be used during the commissioning of the relay: function test and digital input test.

The function test is used for testing the configuration as well as the connections from the relay. By selecting this test, the internal signals from the protection elements, the motor start-up signal, the external trip signal and the IRF function can be activated one by one. Provided that the signals have been set to be routed to the output contacts (PO1...PO3 and SO1...SO5) with the switches of SGR1...SGR8, the output contacts are activated and their corresponding event codes are generated when the test is run. However, activation of the internal signals from the protection elements, the external trip signal and the IRF function do not generate an event code.

The digital input test is used for testing the connections to the relay. The state of the digital inputs can be monitored via the HMI.

Refer to the Operator's Manual for instructions on how to perform the tests.

## 5.1.11. Disturbance recorder

### 5.1.11.1. Function

The relay features an integrated disturbance recorder which continuously captures the curve forms of the voltages as well as the status of both internal signals and the external digital input signals and stores these in the memory.

Triggering of the recorder generates an event code. After the recorder has been triggered, it continues to record data for a pre-defined post-triggering time. An asterisk is shown on the LCD on completion of the recording. The status of the recording can also be viewed using SPA parameter V246.

As soon as the recorder has been triggered and the recording has finished, the recording can be uploaded and analyzed by means of a PC provided with a special program.

### 5.1.11.2. Disturbance recorder data

One recording contains data from the four analog channels and up to eight digital channels. The analog channels, whose data is stored either as RMS curves or as instantaneous measured values, are the voltages measured by the relay. The digital channels, referred to as digital signals, are pickup and trip signals from the protection elements and the digital input signals linked to the relay.

The user can select up to eight digital signals to be recorded. If more than eight signals are selected, the first eight signals are stored, beginning with the internal signals followed by the digital input signals.

The digital signals to be stored are selected with parameters V238 and V243; see Table 5.1.17.-5 and Table 5.1.17.-6.

The recording length varies according to the selected sampling frequency. The RMS curve is recorded by selecting the sampling frequency to be the same as the nominal frequency of the relay. The sampling frequency is selected with SPA parameter M15; see the table below for details.

**Table 5.1.11.2.-1 Sampling frequency**

Nominal frequency Hz	Sampling frequency Hz	Cycles
50	800	250
	400	500
	50 <sup>a)</sup>	4000
60	960	250
	480	500
	60 <sup>a)</sup>	4000

Table footnotes from previous page

a) RMS curve.

Recording length:

$$[s] = \frac{\text{Cycles}}{\text{Nominal frequency [Hz]}} \tag{6}$$

Changing the setting values of parameters M15, V238 and V243 is allowed only when the recorder is not triggered.

The post-triggering recording length defines the time during which the recorder continues to store data after it has been triggered. The length can be changed with SPA parameter V240. If the post-triggering recording length is defined to be the same as the total recording length, no data stored prior to the triggering is retained in the memory. By the time the post-triggering recording finishes, a complete recording is created.

Triggering of the recorder immediately after it has been cleared or the auxiliary voltage connected may result in a shortened total recording length. Disconnection of the auxiliary voltage after the recorder has been triggered, but before the recording has finished, on the other hand, may result in a shortened post-triggering recording length. This, however, does not affect the total recording length.

At a power reset, triggered recorder data is retained in the memory provided that it has been defined non-volatile.

**5.1.11.3.**

**Control and target of disturbance recorder status**

It is possible to control and monitor the recording status of the disturbance recorder by writing to and reading SPA parameters M1, M2 and V246. Reading SPA parameter V246 returns either the value 0 or 1, indicating whether the recorder has not been triggered or triggered and ready to be uploaded. Event code E31 is generated the moment the disturbance recorder is triggered. If the recorder is ready to be uploaded, this is also indicated by an asterisk shown in the lower right-hand corner of the LCD when it is in the idle mode. Target can also be routed to programmable LEDs.

Writing the value 1 to SPA parameter M2 clears the recorder memory and enables the triggering of the recorder. Recorder data can be cleared by performing a master reset, that is, clearing targets and memorized values and unlatching output contacts.

Writing the value 2 to SPA parameter V246 restarts the unloading process by setting the time stamp and the first data ready to be read.

#### 5.1.11.4. **Triggering**

The user can select one or several internal or external digital input signals to trigger the disturbance recorder, either on the rising or falling edge of the signal(s). Triggering on the rising edge means that the post-triggering recording sequence starts when the signal is activated. Correspondingly, triggering on the falling edge means that the post-triggering recording sequence starts when the active signal is reset.

The trigger signal(s) and the edge are selected with SPA parameters V236...V237 and V241...V242; see Table 5.1.17.-5 and Table 5.1.17.-6. The recorder can also be triggered manually with SPA parameter M1.

Triggering of the disturbance recorder is only possible if the recorder is not already triggered.

#### 5.1.11.5. **Settings and unloading**

The setting parameters for the disturbance recorder are V parameters V236...V238, V240...V243 and V246, and M parameters M15, M18, M20 and M80...M83.

Unloading correct information from the recorder requires that M80 and M83 have been set. Unloading is done by using a PC application. The uploaded recorder data is stored in separate files defined by the comtrade® format.

#### 5.1.11.6. **Event code of the disturbance recorder**

The disturbance recorder generates an event code on triggering (E31) and clearing (E32) the recorder. The event mask is determined using SPA parameter V155.

#### 5.1.12. **Recorded data of the last events**

The relay records up to five events. This enables the user to analyze the last five fault conditions in the electrical power network. Each event includes the measured voltages, pickup durations and time stamp, for instance. Additionally, information on the number of pickups of the elements and trips is provided.

Recorded data is non-volatile by default, provided that the battery has been inserted and is charged. A master reset, that is, clearing of targets and memorized values and unlatching of output contacts, erases the contents of the stored events and the number of pickups of the elements.



The number of trips is stored in the non-volatile memory (EEPROM) and is thereby not cleared when performing a master reset. The number of trips can be erased by entering the value 1 into parameter V166.

The relay collects data during fault conditions. When all pickup signals have been reset or an element trips, the collected data and time stamp is stored as EVENT1 and the previously stored events move one step forward. When a sixth event is stored, the oldest event is cleared.

**Table 5.1.12.-1 Recorded data**

REGISTER	Data description
EVENT1	<ul style="list-style-type: none"> <li>Phase-to-phase voltage <math>U_{ab}</math> measured at a time of trip as a multiple of the rated voltage, <math>U_n</math> (VT). The same applies to phase-to-phase voltages <math>U_{bc}</math> and <math>U_{ca}</math>.</li> <li>Residual voltage <math>U_n</math> measured at a time of trip as a percentage of the rated voltage <math>U_n</math> (VT).</li> <li>Maximum voltage value of the phase-to-phase voltages during the last fault conditions in the network, measured as a multiple of the rated voltage <math>U_n</math> (VT)</li> <li>Minimum voltage value of the phase-to-phase voltages during the last fault conditions in the network, measured as a multiple of the rated voltage <math>U_n</math> (VT).</li> <li>Maximum voltage value of the negative phase-sequence voltage during the last fault conditions in the network, measured as a multiple of the rated voltage <math>U_n</math> (VT). If element 59P-2 is not based on negative phase-sequence voltage <math>U_2</math>, dashes are shown on the LCD and "999" when read via serial communication.</li> <li>Minimum voltage value of the positive phase-sequence voltage during the last fault conditions in the network, measured as a multiple of the rated voltage <math>U_n</math> (VT). If element 27P-2 is not based on positive phase-sequence voltage <math>U_1</math>, dashes are shown on the LCD and "999" when read via serial communication.</li> <li>Maximum voltage value of the residual voltage <math>U_n</math> during the last fault conditions in the network, measured as a percentage of the rated voltage <math>U_n</math> (VT).</li> <li>Duration of the last pickup of elements 59P-1, 59P-2/47, 27P-1, 27P-2/27D, 59N-1, 59N-2 and of the external trip, shown as a percentage of the set operate time, or of the calculated operate time at IDMT characteristic. A value other than zero indicates that the corresponding element has picked up whereas a value which is 100% of the set or calculated operate time indicates that the operate time of the element has elapsed, that is, the element has tripped. If the operate time of an element has elapsed but the element is blocked, the value is 99% of the set or calculated operate time.</li> <li>Time stamp for the event. The time when the collected data was stored. The time stamp is displayed in two registers, one including the date expressed as yy-mm-dd, and the other including the time expressed as HH.MM;SS.sss.</li> </ul>
EVENT 2	Same as EVENT 1.
EVENT 3	Same as EVENT 1.
EVENT 4	Same as EVENT 1.
EVENT 5	Same as EVENT 1.
Number of pickups	The number of times each protection element 59P-1, 59P-2/47, 27P-1, 27P-2/27D, 59N-1, 59N-2 has picked up, counting up to 999.
Number of trips	Number of trips: <ul style="list-style-type: none"> <li>Overvoltage element 59P-1, 59P-2 and 47</li> <li>Undervoltage elements 27P-1, 27P-2 and 27D</li> <li>Residual overvoltage elements 59N-1 and 29N-2</li> <li>External trip</li> </ul> When the counters reach their maximum values (65535), they roll over.

### 5.1.13. Communication ports

The relay is provided with an optical communication port (infrared) on the front panel. Rear communication is optional and requires a communication module, which can be provided with either a plastic fibre-optic, combined fibre-optic (plastic and glass) or RS-485 connection. The relay is connected to an automation system via the rear connection. The optional rear communication module allows the use of either the SPA bus, IEC 60870-5-103 or Modbus communication protocol.

For connection to the DNP 3.0 communication system, the relay can be provided with an optional DNP 3.0 rear communication module with RS-485 connection. For further information on optional rear communication module connections, refer to Section 5.2.2. Serial communication connections.



A051551

Fig. 5.1.13.-1 Communication port

#### 1) Front connection for local communication

The relay is connected to a PC used for local parameterization via the infrared port on the front panel. The front connection allows the use of the SPA bus protocol only.

The optical front connection galvanically isolates the PC from the relay. The front connection can be used in two different ways: wirelessly using a PC compatible to the IrDA<sup>®</sup>, Standard specifications or using a specific front communication cable (refer to Section 6. Ordering information). The cable is connected to the serial RS-232 port of the PC. The optical element of the cable is powered by RS-232 control signals. The cable has a fixed baud rate of 9.6 kbps.

The following serial communication parameters are to be set for RS-232:

- Number of data bits: 7
- Number of stop bits: 1
- Parity: even
- Baud rate: 9.6 kbps

Relay data such as events, setting values and all input data and memorized values can be read via the front communication port.

When setting values are altered via the front communication port, the relay checks that the entered parameter values are within the permitted setting range. If an entered value is too high or too low, the setting value remains unchanged.

The relay has a counter which can be accessed via `CONFIGURATION \COMMUNICATION` in the HMI menu. The counter value is set to zero when the relay receives a valid message.

#### 5.1.14.

### IEC 60870-5-103 remote communication protocol

The relay supports the IEC 60870-5-103 remote communication protocol in the unbalanced transmission mode. The IEC 60870-5-103 protocol is used to transfer measurand and status data from the slave to the master. However, the IEC 60870-5-103 protocol cannot be used to transfer disturbance recorder data.

The IEC 60870-5-103 protocol can be used only through the rear connection of the relay on the optional communication module. Connecting the relay to a fibre-optic communication bus requires a fibre-optic communication module. The line-idle state of the fibre-optic communication module can be selected either via the HMI or the SPA bus. According to the IEC 60870-5-103 standard, the line-idle state is “light on”. To ensure communication, the line-idle state should be the same for both the master and the slave device. The connection topology can be selected to be either loop or star, the default being loop, and either via the HMI or the SPA bus. The selected line-idle state and connection topology apply irrespective of which rear communication protocol is active.

The relay uses the SPA bus protocol as default when the optional communication module is in use. The protocol selection is memorized and is therefore always activated when the rear connection is in use. The baud rate can be selected either via the HMI or the SPA bus. According to the IEC 60870-5-103 standard, the baud rate is 9.6 kbps. When the IEC 60870-5-103 protocol is active, event masks are not in use. Consequently, all events in the selected configuration set are included in the event reporting.

The relay is provided with two different selectable configuration sets, of which configuration set 1 is used by default.

Configuration set 1 is intended to be used when the optional I/O module is not installed. Configuration set 2 includes additional information, for example output contact events 6...8 (SO3...SO5) and digital input events 3...5 (DI3...DI5), provided that the optional I/O module is installed.

Function type and information number are mapped into configuration sets according to the IEC 60870-5-103 standard to the extent that these have been defined by the standard. If not defined by the standard, the type of function and/or the information number are/is mapped into a private range.

The tables below indicate the information mapping of the corresponding configuration sets. The column GI indicates whether the status of the specified information object is transmitted within the general interrogation cycle. The relative

time in messages with the type identification 2 is calculated as a time difference between the occurred event and the event specified in the column Relative time. The measurand multiplied by the normalize factor is proportional to the rated value. Therefore, the maximum value of each measurand is the normalize factor multiplied by the rated value.

**Table 5.1.14.-1 Information mapping of configuration set 1 and 2**

Event reason	Event code	Configuration set 1	Configuration set 2	Function type	Information number	GI	Relative time	Type identification
Disturbance recorder Triggered/Cleared	0E31/ 0E32	X	X	178	100	-	-	1
HMI Setting password Opened/Closed	0E33/ 0E34	X	X	178	101	-	-	1
HMI Communication password Opened/Closed	0E35/ 0E36	X	X	178	102	-	-	1
59P-1 Pickup/Reset	1E1/ 1E2	X	X	165	84	X	1E1	2
59P-1 Trip/Reset	1E3/ 1E4	X	X	165	90	-	1E1	2
59P-2 or 47 Pickup/Reset	1E5/ 1E6	X	X	165	94	X	1E5	2
59P-2 or 47 Trip/Reset	1E7/ 1E8	X	X	165	91	-	1E5	2
27P-1 Pickup/Reset	1E9/ 1E10	X	X	166	84	X	1E9	2
27P-1 Trip/Reset	1E11/ 1E12	X	X	166	90	-	1E9	2
27P-2 or 27D Pickup/Reset	1E13/ 1E14	X	X	166	94	X	1E13	2
27P-2 or 27D Trip/Reset	1E15/ 1E16	X	X	166	91	-	1E13	2
59N-1 Pickup/Reset	1E17/ 1E18	X	X	170	84	X	1E17	2
59N-1 Trip/Reset	1E19/ 1E20	X	X	170	90	-	1E17	2
59N-2 Pickup/Reset	1E21/ 1E22	X	X	170	94	X	1E21	2
59N-2 Trip/Reset	1E23/ 1E24	X	X	170	91	-	1E21	2
Trip Lockout/Reset	1E25/ 1E26	X	X	10	223	X	-	1
External Trip/Reset	1E27/ 1E28	X	X	10	222	-	-	1
CBFAIL Activated/Reset	1E29/ 1E30	X	X	160	85	-	-	1

Technical Reference Manual - ANSI Version

Event reason	Event code	Configuration set 1	Configuration set 2	Function type	Information number	GI	Relative time	Type identification
PO1 Activated/Reset	2E1/ 2E2	X	X	251	27	X	-	1
PO2 Activated/Reset	2E3/ 2E4	X	X	251	28	X	-	1
PO3 Activated/Reset	2E5/ 2E6	X	X	251	29	X	-	1
SO1 Activated/Reset	2E7/ 2E8	X	X	251	30	X	-	1
SO2 Activated/Reset	2E9/ 2E10	X	X	251	31	X	-	1
SO3 Activated/Reset	2E11/ 2E12	-	X	251	32	X	-	1
SO4 Activated/Reset	2E13/ 2E14	-	X	251	33	X	-	1
SO5 Activated/Reset	2E15/ 2E16	-	X	251	34	X	-	1
DI1 Activated/Deactivated	2E17/ 2E18	X	X	249	231	X	-	1
DI2 Activated/Deactivated	2E19/ 2E20	X	X	249	232	X	-	1
DI3 Activated/Deactivated	2E21/ 2E22	-	X	249	233	X	-	1
DI4 Activated/Deactivated	2E23/ 2E24	-	X	249	234	X	-	1
DI5 Activated/Deactivated	2E25/ 2E26	-	X	249	235	X	-	1

**Table 5.1.14.-2 Information mapping of configuration set 1 and 2**

Measurand	Normalize factor	Rated value	Configuration set 1	Configuration set 2	Function type	Information number	Type identification
Voltage $U_{ab}$	2.40	$U_n$ (VT)	X	X	135	143	9
Voltage $U_{bc}$	2.40	$U_n$ (VT)	X	X			
Voltage $U_{ca}$	2.40	$U_n$ (VT)	X	X			
Voltage $U_n$	2.40	$U_n$ (VT)	X	X			
Voltage $U_1$	2.40	$U_n$ (VT)	X	X			
Voltage $U_2$	2.40	$U_n$ (VT)	X	X			

**5.1.15.**

**Modbus remote communication protocol**

The master/slave protocol Modbus was first introduced by Modicon Inc. and is widely accepted as a communication standard for industrial device controllers and PLCs. For the protocol definition, refer to Section 1.4. Product documentation.

The implementation of the Modbus protocol in the relay supports both the RTU and the ASCII link mode. Both the link mode and the line setting parameters are user-configurable. The character codings of the link modes follow the protocol definition. The RTU character format is presented in Table 5.1.15.-1 and the ASCII character format in Table 5.1.15.-2:

**Table 5.1.15.-1 RTU character format**

Coding system	8-bit binary
Bits per character	1 pickup bit 8 data bits, the least significant bit is sent first 1 bit for even/odd parity; no bit if parity is not used 1 stop bit if parity is used; 2 stop bits if parity is not used

**Table 5.1.15.-2 ASCII character format**

Coding system	Two ASCII characters representing a hexadecimal number
Bits per character	1 pickup bit 7 data bits, the least significant bit is sent first 1 bit for even/odd parity; no bit if parity is not used 1 stop bit if parity is used; 2 stop bits if parity is not used



The turnaround time (response time) of the relay depends on the amount of data requested in a query. Therefore, the turnaround time can vary between approximately 20 and 100 ms. However, a turnaround timeout no lower than 150 ms is recommended for the Modbus master.



The data address range in the Modbus network follows the protocol definition and starts from 0. Consequently, the data addresses in Table 5.1.15.1.-5...Table 5.1.15.1.-13 are decreased by one when transferred over the network.



The Modbus data type digital input (DI) is commonly also referred to as 1X, coils as 0X, input register (IR) as 3X and holding register (HR) as 4X, of which the former is used here. Thus, HR 123, for instance, can also be referred to as register 400123.

5.1.15.1.

**Profile of Modbus**

The Modbus protocol (ASCII or RTU) is selected via the HMI and can be used only through the rear connection of the relay on the optional communication module. Modbus line settings, that is, parity, CRC byte order and baud rate, can be adjusted either via the HMI or the SPA bus.

The implementation of the Modbus protocol in REU610 supports the following functions:

**Table 5.1.15.1.-1 Supported application functions**

Function code	Function description
01	Read coil status Reads the status of discrete outputs.
02	Read digital input status Reads the status of discrete inputs.
03	Read holding registers Reads the contents of output registers.
04	Read input registers Reads the contents of input registers.
05	Force single coil Sets the status of a discrete output.
06	Preset single register Sets the value of a holding register.
08	Diagnostics Checks the communication system between the master and the slave.
15	Force multiple coils Sets the status of multiple discrete outputs.
16	Preset multiple registers Sets the value of multiple holding registers.
23	Read/write holding registers Exchanges holding registers in one query.

**Table 5.1.15.1.-2 Supported diagnostic subfunctions**

Code	Name	Description
00	Return query data	The data in the query data field is returned (looped back) in the response. The entire response is to be identical to the query.
01	Restart communication option	The slave's peripheral port is initialized and restarted and the communication event counters are cleared. Before this, a normal response will be sent provided that the port is not in the listen only mode. However, if the port is in the listen only mode, no response will be sent.
04	Force listen only mode	The slave is forced to enter the listen only mode for Modbus communication.
10	Clear counters and diagnostic register	All counters and the diagnostic register are cleared.
11	Return bus message count	The number of messages in the communications system detected by the slave since its last restart, clear counters operation or power up is returned in the response.

Code	Name	Description
12	Return bus communication error count	The number of CRC errors encountered by the slave since its last restart, clear counters operation or power up is returned in the response.
13	Return bus exception error count	The number of Modbus exception responses sent by the slave since its last restart, clear counters operation or power up is returned in the response.
14	Return slave message count	The number of messages addressed to the slave or broadcast which the slave has processed since its last restart, clear counters operation or power up is returned in the response.
15	Return slave no response count	The number of messages addressed to the slave for which a response (neither a normal response nor an exception response) has not been sent since its last restart, clear counters operation or power up is returned in the response.
16	Return slave NACK response count	The number of messages addressed to the slave for which a NACK response has been sent is returned in the response.
18	Return bus character overrun count	The number of messages addressed to the slave for which it has not been able to send a response due to a character overrun since its last restart, clear counters operation or power up is returned in the response.



Sending other subfunction codes than those listed above cause an Illegal data value response.

The Modbus protocol provides the following diagnostic counters:

**Table 5.1.15.1.-3 Diagnostic counters**

Name	Description
Bus message count	The number of messages in the communications system detected by the slave since its last pickup, clear counters operation or power up.
Bus communication error count	The number of CRC or LRC errors encountered by the slave since its last restart, clear counters operation or power up.
Bus exception error count	The number of Modbus exception responses sent by the slave since its last restart, clear counters operation or power up.
Slave message count	The number of messages addressed to the slave or broadcast which the slave has processed since its last restart, clear counters operation or power up.

Name	Description
Slave no response count	The number of messages addressed to the slave for which a response (neither a normal response nor an exception response) has not been sent since its last restart, clear counters operation or power up.
Slave NACK response count	The number of messages addressed to the slave for which a NACK response has been sent.
Bus character overrun count	The number of messages addressed to the slave for which it has not been able to send a response due to a character overrun since its last restart, clear counters operation or power up.

The following exception codes may be generated by the Modbus protocol:

**Table 5.1.15.1-4 Possible exception codes**

Code	Name	Description
01	Illegal function	The slave does not support the requested function.
02	Illegal data address	The slave does not support the data address or the number of items in the query is incorrect.
03	Illegal data value	A value contained in the query data field is out of range.
04	Slave device failure	An unrecoverable error has occurred while the slave was attempting to perform the requested task.



If an Illegal data value exception response is generated when attempting to preset multiple registers, the contents of the register to which an illegal value has been imposed and of the following registers is not changed. Registers which have already been preset are not restored.

### User-defined registers

Reading of unwanted data in a data block wastes bandwidth and complicates data interpretation. For optimum efficiency in Modbus communication, data has therefore been organized into consecutive blocks. In addition, a set of programmable user-defined registers (UDR) has been defined in the holding register area.

The first sixteen holding registers, that is, HR1...16, are user-defined registers. The UDRs can be linked to any holding register, except for HR721...727, using SPA parameters 504V1...504V16. However, one UDR cannot be linked to another, that is, linking cannot be nested. Each parameter contains the address of the holding register to which the UDR is linked.

If a UDR is linked to a non-existent holding register, reading from the register fails and an Illegal address exception response is sent. Giving the link address the value 0 disables the UDR. If the master reads from a disabled UDR, the value 0 is returned.

The UDRs are mirrored in HR385...400.

### Fault records

The data recorded during a fault sequence is called a fault record (FR). The slave stores the five latest fault records. When a sixth record is stored, the oldest record is deleted.

To read a fault record:

1. Write a preset single register command (function 06) to HR601 using a selection code as data value.
2. Read the selected fault record (function 04) from HR601, register count 28.

#### Selection code 1: the master reads the oldest unread record

Status register 3 (HR403) informs whether there are unread fault records (see Fig. 5.1.15.1.-2). If there is one or several unread fault records, the master can read the contents using selection code 1.

The fault record contains a sequence number which makes it possible for the master to determine whether one or several unread fault records have been deleted due to overflow. The master compares the sequence number to that of the previously read fault record.

The slave keeps track of which fault record is currently the oldest unread. The master can continue reading fault records for as long as Status register 3 indicates that there are unread records.

- Special case 1: If there are no unread fault records, the contents of the last read record is returned. If the buffer is empty, however, the registers contain only zeros. This is the only time when sequence number zero appears.
- Special case 2: If the master tries to read the next unread fault record without entering selection code 1 again, the contents of the last read record will be returned.

#### Selection code 2: the master reads the oldest stored record

By resetting the read pointer using selection code 2, the master can read the oldest stored fault record. After this, the master can continue reading the following records using selection code 1, irrespective of whether they have been read before.



Resetting the read pointer does not affect the sequence number of the fault record.



A master reset, that is, clearing of targets and memorized values and unlatching of output contacts, clears the fault records, after which the sequence number starts from 1 again.

## Event records

Modbus events are derived from SPA events. With a few exceptions, SPA events update binary points in the DI and the packed HR area. Simultaneously, a corresponding Modbus event record is generated. The event record contains the Modbus DI/CO data point address and the value to which the point has changed (0 or 1). SPA events lacking a corresponding DI/CO data point are shown as SPA channel and event code (informative event) in the event record. The maximum capacity of the Modbus event buffer is 99 events. The time stamp of Modbus events is extended to contain complete information, from date to millisecond.

To read an event record:

1. Write a preset single register command (function 06) to HR671 using a selection code as data value.
2. Read the selected fault record (function 04) from HR672, register count 8.

Alternatively, a fault record can be read using one command (function 23) only.

### Selection code 1: reading the oldest unread record

Status register 3 (HR403) informs whether there are unread event records (see Fig. 5.1.15.1.-2). If there is one or several unread event records, the master can read the contents using selection code 1.

The event record contains a sequence number which makes it possible for the master to determine whether one or several unread event records have been deleted due to overflow by comparing it to the sequence number of the previously read event record.

The slave keeps track of which event record is currently the oldest unread. The master can continue reading event records for as long as Status register 3 indicates that there are unread records.

- Special case 1: If there are no unread event records, the contents of the last read record is returned. If the buffer is empty, however, the registers contain only zeros. This is the only time when sequence number zero appears.
- Special case 2: If the master tries to read the next unread event record without entering selection code 1 again, the contents of the last read record is returned.

### Selection code 2: reading the oldest stored record

By resetting the read pointer using selection code 2, the master can read the oldest stored event record. After this, the master can continue reading the following records using selection code 1, irrespective of whether they have been read before.



Resetting the read pointer does not affect the sequence number of the event record.

### Selection code -1...-99

With selection code -1...-99, the master can move backwards from the newest event as many events as defined by the selection code and read that specific event record. After this, the master can continue reading the following records using selection code 1, irrespective of whether they have been read before.

- Special case: If there is not as many events in the buffer as specified by the selection code, the oldest stored event is read.

### Selection code 3

The Modbus event buffer is cleared with selection code 3. Clearing the buffer does not require any read operation to follow.

### Digital inputs

As the master may not detect the state changes of all digital signals when scanning, an additional change detect (CD) target bit is created for every instantaneous target point; see the example below.

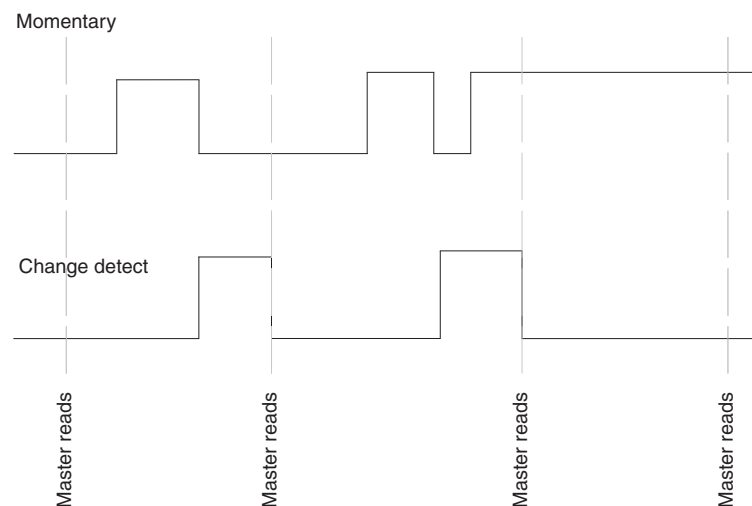

A040332

Fig. 5.1.15.1.-1 Change detection bit

If the instantaneous value of a target bit has changed two or more times since the master last read it, the CD bit is set to one. When the CD bit has been read, it is set to zero.

The instantaneous and the CD bit of a certain target point always occur as a pair in the Modbus memory map.

**Modbus data mapping**

There are two types of monitoring data: digital targets and measurands. For convenience and efficiency, the same data can be read from different data areas. Measurands and other 16-bit values can be read either from the IR or HR (read-only) area and digital target values from either the DI or coil (read-only) area. It is also possible to read the status of the DIs as packed 16-bit registers from both the IR and the HR area.

Consequently, all monitoring data can be read as consecutive blocks of data from the IR or HR area.

The register and bit addresses are presented in the tables below. Some register structures are presented in separate sections below.



The HR and IR values are unsigned 16-bit integers unless otherwise specified.

**Table 5.1.15.1.-5 Mapping of Modbus data: user-defined registers**

Description	HR/IR address (.bit)	DI/Coil bit address	Writeable	Value range	Comment
UDR 1	1 or 385				
UDR 2	2 or 386				
UDR 3	3 or 387				
UDR 4	4 or 388				
UDR 5	5 or 389				
UDR 6	6 or 390				
UDR 7	7 or 391				
UDR 8	8 or 392				
UDR 9	9 or 393				
UDR 10	10 or 394				
UDR 11	11 or 395				
UDR 12	12 or 396				
UDR 13	13 or 397				
UDR 14	14 or 398				
UDR 15	15 or 399				
UDR 16	16 or 400				

**Table 5.1.15.1.-6 Mapping of Modbus data: status registers**

Description	HR/IR address (.bit)	DI/Coil bit address	Writeable	Value range	Comment
Status register 1	401			IRF code	See Structure 1
Status register 2	402			Warning codes	See Structure 1
Status register 3	403				See Structure 1

**Table 5.1.15.1.-7 Mapping of Modbus data: analog data**

Description	HR/IR address (.bit)	DI/Coil bit address	Writeable	Value range	Comment
Phase-to-phase voltage $U_{ab}$	404			0...200	$0...2 \times U_n$ (VT)
Phase-to-phase voltage $U_{bc}$	405			0...200	$0...2 \times U_n$ (VT)
Phase-to-phase voltage $U_{ca}$	406			0...200	$0...2 \times U_n$ (VT)
Residual voltage $U_n$	407			0...200	$0...200\% U_n$ (VT)
Positive phase-sequence voltage	408			0...200	$0...2 \times U_n$ (VT)
Negative phase-sequence voltage	409			0...200	$0...2 \times U_n$ (VT)

**Table 5.1.15.1.-8 Mapping of Modbus data: digital data**

Description	HR/IR address (.bit)	DI/Coil bit address	Writeable	Value range	Comment
Pickup signal from element 59P-1	410.00	1		0/1	1 = activated
Pickup signal from element 59P-1 CD	410.01	2			
Trip signal from element 59P-1	410.02	3		0/1	1 = activated
Trip signal from element 59P-1 CD	410.03	4			
Pickup signal from element 59P-2/47	410.04	5		0/1	1 = activated
Pickup signal from element 59P-2/47 CD	410.05	6			
Trip signal from element 59P-2/47	410.06	7		0/1	1 = activated
Trip signal from element 59P-2/47 CD	410.07	8			
Pickup signal from element 27P-1	410.08	9		0/1	1 = activated
Pickup signal from element 27P-1 CD	410.09	10			
Trip signal from element 27P-1	410.10	11		0/1	1 = activated
Trip signal from element 27P-1 CD	410.11	12			
Pickup signal from element 27P-2/27D	410.12	13		0/1	1 = activated
Pickup signal from element 27P-2/27D CD	410.13	14			
Trip signal from element 27P-2/27D	410.14	15		0/1	1 = activated
Trip signal from element 27P-2/27D CD	410.15	16			
Pickup signal from element 59N-1	411.00	17		0/1	1 = activated
Pickup signal from element 59N-1 CD	411.01	18			
Trip signal from element 59N-1	411.02	19		0/1	1 = activated
Trip signal from element 29N-1 CD	411.03	20			
Pickup signal from element 59N-2	411.04	21		0/1	1 = activated
Pickup signal from element 59N-2 CD	411.05	22			
Trip signal from element 59N-2	411.06	23		0/1	1 = activated
Trip signal from element 59N-2 CD	411.07	24			
Trip lockout	411.08	25		0/1	1 = activated
Trip lockout CD	411.09	26			
External trip	411.10	27		0/1	1 = activated
External trip CD	411.11	28			
CBFAIL	411.12	29		0/1	1 = activated
CBFAIL CD	411.13	30			

Technical Reference Manual - ANSI Version

Description	HR/IR address (.bit)	DI/Coil bit address	Writeable	Value range	Comment
PO1 contact	411.14	31		0/1	1 = activated
PO1 contact CD	411.15	32			
PO2 contact	412.00	33		0/1	1 = activated
PO2 contact CD	412.01	34			
PO3 contact	412.02	35		0/1	1 = activated
PO3 contact CD	412.03	36			
SO1 contact	412.04	37		0/1	1 = activated
SO1 contact CD	412.05	38			
SO2 contact	412.06	39		0/1	1 = activated
SO2 contact CD	412.07	40			
SO3 contact	412.08	41		0/1	1 = activated
SO3 contact CD	412.09	42			
SO4 contact	412.10	43		0/1	1 = activated
SO4 contact CD	412.11	44			
SO5 contact	412.12	45		0/1	1 = activated
SO5 contact CD	412.13	46			
DI1	412.14	47		0/1	1 = activated
DI1 CD	412.15	48			
DI2	413.00	49		0/1	1 =activated
DI2 CD	413.01	50			
DI3	413.02	51		0/1	1 = activated
DI3 CD	413.03	52			
DI4	413.04	53		0/1	1 = activated
DI4 CD	413.05	54			
DI5	413.06	55		0/1	1 = activated
DI5 CD	413.07	56			
Disturbance recorder	413.08	57		0/1	1 = triggered
Disturbance recorder CD	413.09	58			
HMI Setting password	413.10	59		0/1	1 = opened 0 = closed
HMI Setting password CD	413.11	60			
IRF	413.12	61		0/1	1 = activated
IRF CD	413.13	62			
Warning	413.14	63		0/1	1 = activated
Warning CD	413.15	64			
SPA event overflow	414.00	65		0/1	1 = activated
SPA event overflow CD	414.01	66			Only the CD bit is activated in case of overflow.
HMI Communication password	414.02	67		0/1	1 = opened 0 = closed
HMI Communication password CD	414.03	68			

**Table 5.1.15.1.-9 Mapping of Modbus data: recorded data**

Description	HR/IR address (.bit)	DI/Coil bit address	Writeable	Value range	Comment
Fault record	601...623				See Structure 2
Event record	671...679				See Structure 3

**Table 5.1.15.1.-10 Mapping of Modbus data: relay identification**

Description	HR/IR address (.bit)	DI/Coil bit address	Writeable	Value range	Comment
Type designation of the relay	701...708				ASCII chars, 2 chars/register

**Table 5.1.15.1.-11 Mapping of Modbus data: real-time clock**

Description	HR/IR address (.bit)	DI/Coil bit address	Writeable	Value range	Comment
Time reading and setting	721...727		W		See Structure 4

**Table 5.1.15.1.-12 Mapping of Modbus data: additional analog data**

Description	HR/IR address (.bit)	DI/Coil bit address	Writeable	Value range	Comment
Element which caused the operation	801 HI word 802 LO word			0...65536	See Table 5.1.17.-2
Operation target code	803			1...14	See Table 5.1.17.-2
Number of pickups of element 59P-1	804			0...999	Counter
Number of pickups of element 59P-2/47	805			0...999	Counter
Number of pickups of element 27P-1	806			0...999	Counter
Number of pickups of element 27P-2	807			0...999	Counter
Number of pickups of element 59N-1	808			0...999	Counter
Number of pickups of element 59N-2	809			0...999	Counter
Number of trips of element 59P-1 and 59P-2/47	810			0...65535	Counter
Number of trips of element 27P-1 and 27P-2/27D	811			0...65535	Counter
Number of trips of element 59N-1 and 59N-2	812			0...65535	Counter
Number of external trips	813			0...65535	Counter

**Table 5.1.15.1.-13 Mapping of Modbus data: control points**

Description	HR/IR address (.bit)	DI/Coil bit address	Writeable	Value range	Comment
LED reset		501	W	1	1 = LED reset <sup>a)</sup>

<sup>a)</sup> Coil area, only writeable.

## Structure 1

The status registers contain information on unread fault and event records, and relay status. The registers are arranged as in Fig. 5.1.15.1.-2 below.

Technical Reference Manual - ANSI Version

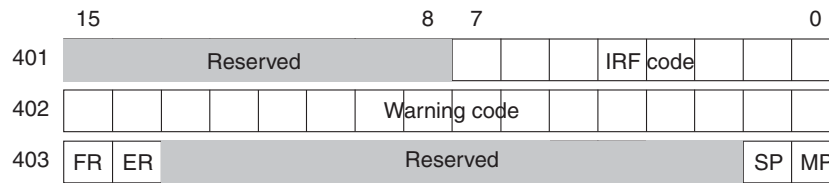

A040333

Fig. 5.1.15.1.-2 Status registers

When the value of the FR/ER bit is 1, there is one or several unread fault/event records. If time synchronization is realized via a digital input, either the SP (second-pulse) or MP (minute-pulse) bit will be activated.

Refer to Table 5.1.18.-1 for IRF codes and Table 5.1.18.-2 for warning codes.

**Structure 2**

This structure contains data recorded during a fault sequence. Refer to Fault records earlier in this section for the reading method.

**Table 5.1.15.1.-14 Fault record**

Address	Signal name	Range	Comment
601	Latest selection code <sup>a)</sup>	1...2	1 = read oldest unread record 2 = read oldest stored record
602	Sequence number	1...255	
603	Unread records left	0...6	
604	Time stamp of the recorded data, date		2 bytes: YY.MM
605	Time stamp of the recorded data, date and time		2 bytes: DD.HH
606	Time stamp of the recorded data, time		2 bytes: MM.SS
607	Time stamp of the recorded data, time	0...999	0...999 ms
608	Phase-to-phase voltage $U_{ab}$	0...200	$0...2 \times U_n$ (VT)
609	Phase-to-phase voltage $U_{bc}$	0...200	$0...2 \times U_n$ (VT)
610	Phase-to-phase voltage $U_{ca}$	0...200	$0...2 \times U_n$ (VT)
611	Residual voltage $U_n$	0...200	$0...200\% U_n$ (VT)
612	Maximum pickup phase-to-phase voltage	0...200	$0...2 \times U_n$ (VT)
613	Minimum pickup phase-to-phase voltage	0...200	$0...2 \times U_n$ (VT)
614	Maximum pickup negative phase-sequence voltage $U_2$	0...200	$0...2 \times U_n$ (VT) <sup>b)</sup>
615	Minimum pickup positive phase-sequence voltage $U_1$	0...200	$0...2 \times U_n$ (VT) <sup>b)</sup>
616	Maximum residual voltage $U_n$	0...200	$0...200\% U_n$ (VT)
617	Pickup duration of element 59P-1	0...100	0...100%
618	Pickup duration of element 59P-2/47	0...100	0...100%
619	Pickup duration of element 27P-1	0...100	0...100%
620	Pickup duration of element 27P-2/27D	0...100	0...100%

Address	Signal name	Range	Comment
621	Pickup duration of element 59N-1	0...100	0...100%
622	Pickup duration of element 59N-2	0...100	0...100%
623	Pickup duration of external trip	0/100	0/100%

a) Readable and writeable register.

b) If not in use, the value 655 is returned.

### Structure 3

This structure contains Modbus event records. Refer to Event records earlier in this section for the reading method.

**Table 5.1.15.1.-15 Event record**

Address	Signal name	Range	Comment
671	Latest selection code <sup>a)</sup>	1...3  -1...-99	1 = read oldest unread record 2 = read oldest stored record 3 = clear Modbus event buffer  -1...-99 = move to the nth newest record
672	Sequence number	1...255	
673	Unread records left	0...99	
674	Time stamp of the event, date		2 bytes: YY.MM
675	Time stamp of the event, date and time		2 bytes: DD.HH
676	Time stamp of the event, time		2 bytes: MM.SS
677	Time stamp of the event, time	0...999	0...999 ms
678	Event data		See Table 5.1.15.1.-16 for Modbus DI-point events and Table 5.1.15.1.-17 for informative events
679			

a) Readable and writeable register.

**Table 5.1.15.1.-16 Modbus DI-point event**

Address	Name	Range	Comment
678	0   Modbus DI-point	1...99	MSB = 0
679	Modbus DI value	0...1	

**Table 5.1.15.1.-17 Informative event**

Address	Name	Range	Comment
678	1   SPA channel	0...3	MSB = 1
679	SPA event	0...63	

### Structure 4

The relay's real-time clock is stored in this structure. It can be updated by presetting the whole register structure in one Modbus transaction.

**Table 5.1.15.1.-18 Real-time clock structure**

Address	Description	Range
721	Year	0...99
722	Month	1...12
723	Day	1...31
724	Hour	0...23
725	Minute	0...59
726	Second	0...59
727	Hundredth of a second	0...99

**5.1.16. DNP 3.0 remote communication protocol**

The DNP 3.0 protocol was developed by Harris Control based on the early versions of the IEC 60870-5 standard telecontrol protocol specifications. Today, the DNP protocol specifications are controlled by the DNP Users Group.

The DNP protocol supports the ISO OSI (Open System Interconnection) based model, which only specifies physical, data link and application layers. This reduced protocol stack is referred to as Enhanced Performance Architecture (EPA). To support advanced RTU functions and messages larger than the maximum frame length as defined in the IEC 60870-1, the DNP 3.0 Data Link is to be used with a transport pseudo-layer. As a minimum, the transport pseudo-layer implements message assembly and disassembly services.

**5.1.16.1. Protocol parameters**

The DNP parameters can all be adjusted using Relay Setting Tool. For the DNP parameters, refer to Table 5.1.17.-13.

**Storing DNP 3.0 parameters**

All DNP parameters are stored on the external DNP 3.0 module. After parameterization with Relay Setting Tool, REU610 must be switched to the rear communication mode for at least 10 seconds in order for the DNP parameters to be replicated and stored onto the DNP module. However, this is necessary only if the DNP parameters have been altered.

**5.1.16.2. DNP 3.0 point list**

The DNP data points (binary, analog and counters) of the relay, presented in Table 5.1.16.2.-1...Table 5.1.16.2.-3, are all in use as default.

The default class settings of the DNP points within the different event object groups are:

- Binary inputs change events: class 1
- Analog inputs change events: class 2
- Counter change events: class 3

All static data points belong to class 0.

Unsolicited reporting is enabled for all event objects as default. However, the point-specific enable/disable parameters are meaningless unless unsolicited reporting has been enabled with SPA parameter 503V24.

The pointers to the scaling factors for analog objects are all 0 as default. Consequently, the DNP and Modbus analog values of the relay are identical as default.

All DNP process points can be edited using Relay Setting Tool. Editing features include:

- Re-organizing, adding and removing DNP points
- Assigning event classes to specific DNP points
- DNP point-specific enabling/disabling of unsolicited reporting
- Defining deadbands for event reporting
- Defining scaling factors for analog values

**Table 5.1.16.2.-1 Binary data**

Description	DNP point address	Event class	UR enable	Value range	Comment
Pickup signal from element 59P-1	0	1	1	0/1	1 = activated
Trip signal from element 59P-1	1	1	1	0/1	1 = activated
Pickup signal from element 59P-2/47	2	1	1	0/1	1 = activated
Trip signal from element 59P-2/47	3	1	1	0/1	1 = activated
Pickup signal from 27P-1	4	1	1	0/1	1 = activated
Trip signal from element 27P-1	5	1	1	0/1	1 = activated
Pickup signal from element 27P-2/27D	6	1	1	0/1	1 = activated
Trip signal from element 27P-2/27D	7	1	1	0/1	1 = activated
Pickup signal from element 59N-1	8	1	1	0/1	1 = activated
Trip signal from element 59N-1	9	1	1	0/1	1 = activated
Pickup signal from element 59N-2	10	1	1	0/1	1 = activated
Trip signal from element 59N-2	11	1	1	0/1	1 = activated
Trip lockout signal	12	1	1	0/1	1 = activated
External trip signal	13	1	1	0/1	1 = activated
CBFAIL	14	1	1	0/1	1 = failure
PO1	15	1	1	0/1	1 = activated
PO2	16	1	1	0/1	1 = activated
PO3	17	1	1	0/1	1 = activated
SO1	18	1	1	0/1	1 = activated
SO2	19	1	1	0/1	1 = activated
SO3	20	1	1	0/1	1 = activated
SO4	21	1	1	0/1	1 = activated

## Technical Reference Manual - ANSI Version

Description	DNP point address	Event class	UR enable	Value range	Comment
SO5	22	1	1	0/1	1 = activated
DI1	23	1	1	0/1	1 = activated
DI2	24	1	1	0/1	1 = activated
DI3	25	1	1	0/1	1 = activated
DI4	26	1	1	0/1	1 = activated
DI5	27	1	1	0/1	1 = activated
Disturbance recorder	28	1	1	0/1	1 = triggered 0 = cleared
HMI Setting password	29	1	1	0/1	1 = opened 0 = closed
IRF	30	1	1	0/1	1 = activated
Warning	31	1	1	0/1	1 = activated
SPA event overflow	32	1	1	0/1	1 = activated
HMI Communication password	33	1	1	0/1	1 = opened 0 = closed

Table 5.1.16.2-2 Analog data

Description	DNP point address	Event class	UR enable	Deadband	Value range	Internal scaling factor (ix = 0)
Phase-to-phase voltage $U_{ab}$	0	2	0	1	0...200	100
Phase-to-phase voltage $U_{bc}$	1	2	0	1	0...200	100
Phase-to-phase voltage $U_{ca}$	2	2	0	1	0...200	100
Residual voltage $U_n$	3	2	0	1	0...200	100
Positive phase-sequence voltage	4	2	0	1	0...200	100
Negative phase-sequence voltage	5	2	0	1	0...200	100

Table 5.1.16.2-3 Counters

Description	DNP point address	Event class	UR enable	Deadband	Value range
Number of pickups of element 59P-1	0	3	0	1	0...999
Number of pickups of element 59P-2/47	1	3	0	1	0...999
Number of pickups of element 27P-1	2	3	0	1	0...999
Number of pickups of element 27P-2/27D	3	3	0	1	0...999
Number of pickups of element 59N-1	4	3	0	1	0...999
Number of pickups of element 59N-2	5	3	0	1	0...999
Number of trips of element 59P-1 and 59P-2/47	6	3	0	1	0...65535
Number of trips of element 27P-1 and 27P-2/27D	7	3	0	1	0...65535
Number of trips of element 59N-1 and 59N-2	8	3	0	1	0...65535
Number of external trips	9	3	0	1	0...65535

**5.1.16.3. DNP 3.0 device profile**

<b>DNP V3.00</b>	
<b>DEVICE PROFILE DOCUMENT</b>	
Vendor Name: ABB Oy, Distribution Automation, Vaasa, Finland	
Device Name: REU610	
Highest DNP Level Supported For Requests           I <sub>b</sub>	Device Function <input checked="" type="checkbox"/> Slave
For Responses        I <sub>b</sub>	
Notable objects, functions, and/or qualifiers supported in addition to the Highest DNP Levels Supported (the complete list is described in the attached table): Additions to level 2 are marked as shaded in the implementation table	
Maximum Data Link Frame Size (octets) Transmitted           292 Received               292	Maximum Application Fragment Size (octets) Transmitted           2048 Received               2048
Maximum Data Link Re-tries:	Maximum Application Layer Re-tries:
Configurable, range from 0 to 255 with primary data link layer retransmission count	Configurable, range from 0 to 255 with application layer retransmission count
Requires Data Link Layer Confirmation: Configurable, with confirmation type selector, default NO ACK	
Requires Application Layer Confirmation <input checked="" type="checkbox"/> Configurable with confirmation type selector when reporting Event Data (Slave devices only) <input checked="" type="checkbox"/> Always after response to reset request	
<input type="checkbox"/> Always when sending multi-fragment responses (Slave devices only) <input checked="" type="checkbox"/> Configurable, with confirmation type selector	
Timeouts while waiting for:	
Data Link Confirm	Configurable with primary data link layer timeout, not relevant when NO ACK
Complete Appl. Fragment	No, multi-fragment application frames not supported
Application Confirm	Configurable with application layer timeout
Complete Appl. Response	No, not relevant in slave
Sends/Executes Control Operations	
WRITE Binary Outputs	<input checked="" type="checkbox"/> Never
SELECT/OPERATE	<input checked="" type="checkbox"/> Never
DIRECT OPERATE	<input checked="" type="checkbox"/> Never
DIRECT OPERATE - NO ACK	<input checked="" type="checkbox"/> Never
Count	<input checked="" type="checkbox"/> Never
Code	<input checked="" type="checkbox"/> Never
Trip/Close	<input checked="" type="checkbox"/> Never
Pulse On	<input checked="" type="checkbox"/> Never
Queue	<input checked="" type="checkbox"/> Never
Clear Queue	<input checked="" type="checkbox"/> Never
<b>FILL OUT THE FOLLOWING ITEMS FOR SLAVE DEVICES ONLY:</b>	
Reports Digital Input Change Events when no specific variation requested	Reports time-tagged Digital Input Change Events when no specific variation requested

Technical Reference Manual - ANSI Version

<input type="checkbox"/> Never <input type="checkbox"/> Only time-tagged <input type="checkbox"/> Only non-time-tagged <input checked="" type="checkbox"/> Configurable to send both, one or the other (depends on default variation)	<input type="checkbox"/> Never <input checked="" type="checkbox"/> Binary Input Change With Time <input type="checkbox"/> Binary Input Change With Relative Time <input type="checkbox"/> Configurable, depends on objects basic variation (variation used at initialization)
Sends Unsolicited Responses <input type="checkbox"/> Never <input checked="" type="checkbox"/> Configurable <input type="checkbox"/> Only certain objects <input type="checkbox"/> Sometimes (attach explanation) <input checked="" type="checkbox"/> ENABLE/DISABLE UNSOLICITED Function codes supported	Sends Static Data in Unsolicited Responses <input checked="" type="checkbox"/> Never <input type="checkbox"/> When Device Restarts <input type="checkbox"/> When Status Flags Change  No other options are permitted.
Default Counter Object/Variation <input type="checkbox"/> No Counters Reported	Counters Roll Over at <input type="checkbox"/> No Counters Reported
<input type="checkbox"/> Configurable, default object and variation <input checked="" type="checkbox"/> Default Object 20 Default Variation 2 <input type="checkbox"/> Point-by-point list attached	<input type="checkbox"/> Configurable (attach explanation) <input checked="" type="checkbox"/> 16 Bits (Counters 6...9) <input type="checkbox"/> 32 Bits, but roll-over bits not used
	<input checked="" type="checkbox"/> Other value: 999 (Counters 0...5) and 255 (Counters 10...21) <input type="checkbox"/> Point-by-point list attached
Sends Multi-Fragment Responses	<input type="checkbox"/> Yes <input checked="" type="checkbox"/> No

Table 5.1.16.3.-1 Supported function codes

Code	Function	Description	Supported
<b>Transfer Function Codes</b>			
0	Confirm	Message fragment confirmation No response	Yes
1	Read	Request objects from outstation Respond with requested objects	Yes
2	Write	Store specified objects to outstation Respond with status of operation	Yes
<b>Control Function Codes</b>			
3	Select	Select output point of outstation Respond with status of control point	No
4	Operate	Set previously selected output Respond with status of control point	No
5	Direct operate	Set output directly Respond with status of control point	No
6	Direct operate NO ACK	Set output directly No response	No
<b>Freeze Function Codes</b>			
7	Immediate Freeze	Copy specified objects to freeze buffer Respond with status of operation	Yes
8	Immediate Freeze NO ACK	Copy specified objects to freeze buffer No response	Yes

Code	Function	Description	Supported
9	Freeze and Clear	Copy specified objects to freeze buffer and clear objects Respond with status of operation	Yes <sup>a)</sup>
10	Freeze and Clear NO ACK	Copy specified objects to freeze buffer and clear objects No response	Yes <sup>a)</sup>
11	Freeze with time	Copy specified objects to freeze buffer at specified time Respond with status of operation	No
12	Freeze with time NO ACK	Copy specified objects to freeze buffer at specified time No response	No
<b>Application Control Function Codes</b>			
13	Cold Restart	Perform desired reset sequence Respond with a time object	Yes
14	Warm Restart	Perform desired partial reset operation Respond with a time object	Yes
15	Initialize Data to Defaults	Initialize the specified data to default Respond with status of operation	No
16	Initialize Application	Set the specified application ready to be run Respond with status of operation	No
17	Start Application	Start the specified application to run Respond with status of operation	Yes
18	Stop Application	Stop the specified application to run Respond with status of operation	Yes
<b>Configuration Function Codes</b>			
19	Save configuration	Save configuration Respond with status of operation	No
20	Enable Unsolicited Messages	Enable Unsolicited Messages Respond with status of operation	Yes
21	Disable Unsolicited Messages	Disable Unsolicited Messages Respond with status of operation	Yes
22	Assign Class	Assign specified objects to a class Respond with status of operation	Yes
<b>Time Synchronization Function Codes</b>			
23	Delay Measurement	Perform propagation delay measurement	Yes
<b>Response Function Codes</b>			
0	Confirm	Message fragment confirmation	Yes
129	Response	Response to request message	Yes
130	Unsolicited Message	Spontaneous message without request	Yes

<sup>a)</sup> Counters of the relay cannot be cleared by using the DNP 3.0 protocol.

**Table 5.1.16.3.-2 Supported objects**

OBJECT			REQUEST (slave must parse)		RESPONSE (master must parse)	
Object group	Variation	Description	Function codes (dec)	Qualifier codes (hex)	Function codes (dec)	Qualifier codes (hex)
1	0	Binary Input, all variations	1, 20, 21, 22	00, 01, 06, 07, 08, 17, 28	129	00, 01, 17, 28
1	1	Binary Input	1, 20, 21, 22	00, 01, 06, 07, 08, 17, 28	129	00, 01, 17, 28
1	2	Binary Input with Status	1, 20, 21, 22,	00, 01, 06, 07, 08 17, 28	129	00, 01, 17, 28

Technical Reference Manual - ANSI Version

OBJECT			REQUEST (slave must parse)		RESPONSE (master must parse)	
Object group	Variation	Description	Function codes (dec)	Qualifier codes (hex)	Function codes (dec)	Qualifier codes (hex)
2	0	Binary Input Change, all variation	1	06, 07, 08		
2	1	Binary Input Change without Time	1	06, 07, 08	129, 130	17, 28
2	2	Binary Input Change with Time	1	06, 07, 08	129, 130	17, 28
2	3	Binary Input Change with Relative Time				
10	0	Binary Output, all variations				
10	1	Binary Output				
10	2	Binary Output with Status				
12	0	Control Block, all variations				
12	1	Control Relay Output Block				
12	2	Pattern Control Block				
12	3	Pattern Mask				
20	0	Binary Counter, all variations	1, 7, 8, 20, 21, 22	00, 01, 06, 07, 08, 17, 28	129	00, 01, 17, 28
20	1	32-Bit Binary Counter	1, 7, 8, 20, 21, 22	00, 01, 06, 07, 08, 17, 28	129	00, 01, 17, 28
20	2	16-Bit Binary Counter	1, 7, 8, 20, 21, 22	00, 01, 06, 07, 08, 17, 28	129	00, 01, 17, 28
20	3	32-Bit Delta Counter				
20	4	16-Bit Delta Counter				
20	5	32-Bit Binary Counter without Flag				
20	6	16-Bit Binary Counter without Flag				
20	7	32-Bit Delta Counter without Flag				
20	8	16-Bit Delta Counter without Flag				
21	0	Frozen Counter, all variations	1	00, 01, 06, 07, 08, 17, 28	129	00, 01, 17, 28
21	1	32-Bit Frozen Counter	1	00, 01, 06, 07, 08, 17, 28	129	00, 01, 17, 28
21	2	16-Bit Frozen Counter	1	00, 01, 06, 07, 08, 17, 28	129	00, 01, 17, 28
21	3	32-Bit Frozen Delta Counter				
21	4	16-Bit Frozen Delta Counter				
21	5	32-Bit Frozen Counter with Time of Freeze	1	00, 01, 06, 07, 08, 17, 28	129	00, 01, 17, 28
21	6	16-Bit Frozen Counter with Time of Freeze	1	00, 01, 06, 07, 08, 17, 28	129	00, 01, 17, 28
21	7	32-Bit Frozen Delta Counter with Time of Freeze				
21	8	16-Bit Frozen Delta Counter with Time of Freeze				
21	9	32-Bit Frozen Counter without Flag				
21	10	16-Bit Frozen Counter without Flag				
21	11	32-Bit Frozen Delta Counter without Flag				

## Technical Reference Manual - ANSI Version

OBJECT			REQUEST (slave must parse)		RESPONSE (master must parse)	
Object group	Variation	Description	Function codes (dec)	Qualifier codes (hex)	Function codes (dec)	Qualifier codes (hex)
21	12	16-Bit Frozen Delta Counter without Flag				
22	0	Counter Change Event, all variations	1	06, 07, 08	129, 130	17, 28
22	1	32-Bit Counter Change Event without Time	1	06, 07, 08	129, 130	17, 28
22	2	16-Bit Counter Change Event without Time	1	06, 07, 08	129, 130	17, 28
22	3	32-Bit Delta Counter Change Event without Time				
22	4	16-Bit Delta Counter Change Event without Time				
22	5	32-Bit Counter Change Event with Time	1	06, 07, 08	129, 130	17, 28
22	6	16-Bit Counter Change Event with Time	1	06, 07, 08	129, 130	17, 28
22	7	32-Bit Delta Counter Change Event with Time				
22	8	16-Bit Delta Counter Change Event with Time				
23	0	Frozen Counter Event, all variations				
23	1	32-Bit Frozen Counter Event without Time				
23	2	16-Bit Frozen Counter Event without Time				
23	3	32-Bit Frozen Delta Counter Event without Time				
23	4	16-Bit Frozen Delta Counter Event without Time				
23	5	32-Bit Frozen Counter Event with Time				
23	6	16-Bit Frozen Counter Event with Time				
23	7	32-Bit Frozen Delta Counter Event with Time				
23	8	16-Bit Frozen Delta Counter Event with Time				
30	0	Analog Input, all variations	1, 20, 21, 22	00, 01, 06, 07, 08 17, 28	129	00, 01, 17, 28
30	1	32-Bit Analog Input	1, 20, 21, 22	00, 01, 06, 07, 08 17, 28	129	00, 01, 17, 28
30	2	16-Bit Analog Input	1, 20, 21, 22	00, 01, 06, 07, 08 17, 28	129	00, 01, 17, 28
30	3	32-Bit Analog Input without Flag	1, 20, 21, 22	00, 01, 06, 07, 08 17, 28	129	00, 01, 17, 28

Technical Reference Manual - ANSI Version

OBJECT			REQUEST (slave must parse)		RESPONSE (master must parse)	
Object group	Variation	Description	Function codes (dec)	Qualifier codes (hex)	Function codes (dec)	Qualifier codes (hex)
30	4	16-Bit Analog Input without Flag	1, 20, 21, 22	00, 01, 06, 07, 08 17, 28	129	00, 01, 17, 28
31	0	Frozen Analog Input, all variations				
31	1	32-Bit Frozen Analog Input				
31	2	16-Bit Frozen Analog Input				
31	3	32-Bit Frozen Analog Input with Time of Freeze				
31	4	16-Bit Frozen Analog Input with Time of Freeze				
31	5	32-Bit Frozen Analog Input without Flag				
31	6	16-Bit Frozen Analog Input without Flag				
32	0	Analog Change Event, all variations	1	06, 07, 08	129, 130	17, 28
32	1	32-Bit Analog Change Event without Time	1	06, 07, 08	129, 130	17, 28
32	2	16-Bit Analog Change Event without Time	1	06, 07, 08	129, 130	17, 28
32	3	32-Bit Analog Change Event with Time	1	06, 07, 08	129, 130	17, 28
32	4	16-Bit Analog Change Event with Time	1	06, 07, 08	129, 130	17, 28
33	0	Frozen Analog Event, all variations				
33	1	32-Bit Frozen Analog Event without Time				
33	2	16-Bit Frozen Analog Event without Time				
33	3	32-Bit Frozen Analog Event with Time				
33	4	16-Bit Frozen Analog Event with Time				
40	0	Analog Output Status, all variations				
40	1	32-Bit Analog Output Status				
40	2	16-Bit Analog Output Status				
41	0	Analog Output Block, all variations				
41	1	32-Bit Analog Output Block				
41	2	16-Bit Analog Output Block				
50	0	Time and Date, all variations	1	06, 07, 08	129	17, 28
50	1 (def)	Time and Date	1	06, 07, 08	129	17, 28
50	1 (def)	Time and Date	2	06, 07, 08	129	
50	2	Time and Date with Interval				
51	0	Time and Date CTO, all variations				
51	1	Time and Date CTO				

OBJECT			REQUEST (slave must parse)		RESPONSE (master must parse)	
Object group	Variation	Description	Function codes (dec)	Qualifier codes (hex)	Function codes (dec)	Qualifier codes (hex)
51	2	Unsynchronized Time and Date CTO				
52	0	Time Delay, all variations				
52	1	Time Delay Coarse				
52	2	Time Delay Fine	23	7	129	7
60	0	All classes	1	6	129	28
60	1	Class 0 Data	1	06, 07, 08	129	17, 28
60	2	Class 1 Data	1	06, 07, 08	129	17, 28
60	3	Class 2 Data	1	06, 07, 08	129	17, 28
60	4	Class 3 Data	1	06, 07, 08	129	17, 28
70	1	File Identifier				
80	1	Internal Targets	2	00	129	
81	1	Storage Object				
82	1	Device Profile				
83	1	Private Registration Object				
83	2	Private Registration Object Descriptor				
90	1	Application Identifier				
100	1	Short Floating Point				
100	2	Long Floating Point				
100	3	Extended Floating Point				
101	1	Small Packed Binary-Coded Decimal				
101	2	Medium Packed Binary-Coded Decimal				
101	3	Large Packed Binary-Coded Decimal				
		No Object	13, 14			

#### 5.1.16.4. Specific DNP features

##### Time synchronization

If time synchronization (minute-pulse or second-pulse) of the relay's real-time clock is realized via a digital input, the following applies to the DNP interface of the relay:

- Depending on the pulse type, either the date-to-minute or the date-to-second information of the DNP time synchronization message is used.
- The relay sends only one request for time synchronization to the DNP master, which is at power up.

### Unsolicited reporting pick up

Due to implementation differences in DNP master devices, the following alternative unsolicited reporting (SPA parameter 503V24) pick ups are available in the relay:

- 1 = Unsolicited reporting starts immediately, without permission from the master.
- 2 = The relay sends an empty unsolicited response message when communication begins, which the master confirms. After this, the relay starts to send unsolicited responses.
- 3 = The relay sends an empty unsolicited response message when communication begins, which the master confirms. After this, the master enables unsolicited reporting for certain or all classes using function 20. Classes which are not enabled remain disabled.



Only the last alternative is compliant with the DNP 3.0 standard.

### Event handling

The maximum capacity of the DNP event buffer is 100 events. When unsolicited reporting has been enabled (SPA parameter 503V24), the event reporting uses the following SPA parameters, called send throttle parameters:

503V18	Class 1 Event delay
503V19	Class 1 Event count
503V20	Class 2 Event delay
503V21	Class 2 Event count
503V22	Class 3 Event delay
503V23	Class 3 Event count

#### Example:

(class 1)

The events are reported when the event delay (SPA parameter 503V18) has elapsed or the defined amount of events (SPA parameter 503V19) are generated for class 1.

If send throttles are not wanted, the event delay should be set to 0 and the event count to 1. In this case, the class events are sent to the host immediately as they occur.

### Event buffer overflow

DNP 3.0 event buffer overflow is indicated with the internal target IIN2.3, as defined by the standard. IIN2.3 can also indicate event buffer overflow in the internal communication between the DNP3.0 module and the main CPU module of the relay. In this case, the relay automatically activates and resets the IIN2.3 bit.

As events have been lost in both cases, the DNP 3.0 master should perform an integrity scan after the IIN2.3 bit has been reset.

### DNP counters and frozen counters

DNP counters in use have a corresponding frozen counter. The frozen counters in object group 21 have the same DNP point index as the ordinary DNP counters. Further, frozen counters can only be read as static objects, and frozen counter events (object group 23) are not supported.

### Collision avoidance and detection

The relay supports both collision avoidance and detection. Collision detection can be enabled or disabled with SPA parameter 503V235. Collision avoidance occurs before message transmission. When preparing to transmit and the link is busy, the relay first waits until the link becomes idle. After this, a backoff time starts. When the backoff time elapses, the relay checks the link again. If the link is not busy, the relay starts the transmission. The backoff time is calculated as follows:

backoff time = silent interval + random delay

The silent interval is set with SPA parameter 503V232 and the maximum random delay with SPA parameters 503V233 (the width of a single time slot in milliseconds) and 503V234 (the maximum number of time slots). By setting the time-slot width to 10 milliseconds and the maximum number of time slots to 10, for instance, the maximum random delay is 100 milliseconds.



In a network consisting of several slaves, the priority between the devices are defined with SPA parameters 503V233 and 503V234. A device with shorter silent interval and maximum random delay has higher sending priority than a device with longer silent interval and maximum random delay.

Collision detection is always active during transmission (provided that it has been enabled). While sending a message, the relay supervises collisions on the link. If a collision is detected, the transmission is immediately cancelled. After this, the relay tries to transmit the message again, using collision avoidance before sending the message.

### Scaling DNP analog values

The DNP analog values can be scaled using either an internal (fixed) or a user-defined scaling factor. If the scaling factor index for a certain analog value is set to 0, the internal scaling factor is used. If set to 1...5, the user-defined scaling factor of the corresponding scaling factor parameter, SPA parameter 503V (100+index), is used:

503V101	Scaling factor 1
503V102	Scaling factor 2
503V103	Scaling factor 3
503V104	Scaling factor 4
503V105	Scaling factor 5

**Example:**

Phase-to-phase voltage $U_{ab}$	$0...2 \times U_n$ (VT)
Internal scaling factor	100
Default DNP range	0...200

To show the analog value in primary units, and if  $U_n$  (VT) = 20000 V:

1. Take any unused scaling factor and set it to 20000.
2. Set the scaling index pointer of the analog value to point at the scaling factor.
3. The value range is now  $0.00 \times 20000...2.00 \times 20000 = 0...20000$  V.

**DNP analog values deadband**

The deadband is always defined in units of the original value when scaled using the internal (fixed) scaling factor, irrespective of whether the internal scaling factor is used for value presentation or not.

**Example:**

For a deadband of 2%  $U_n$  (VT) when the internal scaling factor is 100, the deadband value is set as follows:  $0.02 \times 100 = 2$ . If the scaling factor is set to 20 kV, the scaled deadband is  $20 \text{ kV} \times 0.02 = 400$  V

**5.1.17.**

**SPA bus communication protocol parameters**

Altering parameter values via serial communication requires the use of the SPA password in some cases. The password is a user-defined number within the range 1...999, the default value being 001. SPA parameters are found on channels 0...5, 503...504, 507 and 601...603.

To enter the setting mode, enter the password into parameter V160. To exit the setting mode, enter the same password into parameter V161. The password protection is also reactivated in case of loss of auxiliary voltage.

The password can be changed with parameter V162, but it is not possible to read the password via this parameter. Abbreviations used in the following tables:

- R = readable data
- W = writeable data
- P = password protected writeable data

## Settings

**Table 5.1.17.-1 Settings**

Variable	Actual settings (R), channel 0	Group/Channel 1 (R, W, P)	Group/Channel 2 (R, W, P)	Setting range
Pickup value of element 59P-1	S1	1S1	2S1	0.60...1.40 × (VT)
Operate time of element 59P-1	S2	1S2	2S2	0.06...600 s
IDMT operation mode setting for element 59P-1	S3	1S3	2S3	0...2
IDMT time dial 59P-1 TD	S4	1S4	2S4	0.05...2.00
Resetting time of element 59P-1	S5	1S5	2S5	0.07...60.0 s
Drop-off/pickup ratio 59P-1 D/P	S6	1S6	2S6	0.95...0.99
U <sub>1</sub> /U <sub>2</sub> mode setting of elements 59P-2/27P-2	S7	1S7	2S7	0 = 59P-2 and 27P-2 1 = 59P-2 and 27D 2 = 27P-2 and 47
Pickup value of element 59P-2	S8 <sup>a)</sup>	1S8	2S8	0.80...1.60 × U <sub>n</sub> (VT)
Pickup value of element 47	S9 <sup>a)</sup>	1S9	2S9	0.05...1.00 × U <sub>n</sub> (VT)
Operate time of element 59P-2	S10	1S10	2S10	0.05...600 s
IDMT operation mode setting for element 59P-2	S11	1S11	2S11	0...2
IDMT time dial 59P-2 TD	S12	1S12	2S12	0.05...2.00
Pickup value of element 27P-1	S13	1S13	2S13	0.20...1.20 × U <sub>n</sub> (VT)
Operate time of element 27P-1	S14	1S14	2S14	0.10...600 s
IDMT operation mode setting for element 27P-1	S15	1S15	2S15	0...1
IDMT dial 27P-1 TD	S16	1S16	2S16	0.10...2.00
Resetting time of element 27P-1	S17	1S17	2S17	0.07...60.0 s
Drop-off/pickup ratio 27P-1 D/P	S18	1S18	2S18	1.01...1.05
Pickup value of element 27P-2	S19 <sup>a)</sup>	1S19	2S19	0.20...1.20 × U <sub>n</sub> (VT)
Pickup value of element U <sub>1</sub>	S20 <sup>a)</sup>	1S20	2S20	0.20...1.20 × U <sub>n</sub> (VT)
Operate time of element 27P-2	S21	1S21	2S21	0.10...600 s
IDMT operation mode setting for element 27P-2	S22	1S22	2S22	0...1
IDMT time dial 27P-2 TD	S23	1S23	2S23	0.10...2.00
Pickup value of element 59N-1	S24	1S24	2S24	2.0...80.0% U <sub>n</sub> (VT)
Operate time of element 59N-1	S25	1S25	2S25	0.10...600 s
Resetting time of element 59N-1	S26	1S26	2S26	0.07...60.0 s
Pickup value of element 59N-2	S27 <sup>a)</sup>	1S27	2S27	2.0...80.0% U <sub>n</sub> (VT)
Operate time of element 59N-2	S28	1S28	2S28	0.10...600 s
Predefined time of CBFAIL	S29	1S29	2S29	0.10...60.0 s
Checksum, SGF 1	S61	1S61	2S61	0...255
Checksum, SGF 2	S62	1S62	2S62	0...4095
Checksum, SGF 3	S63	1S63	2S63	0...15
Checksum, SGF 4	S64	1S64	2S64	0...1023
Checksum, SGF 5	S65	1S65	2S65	0...255
Checksum, SGB 1	S71	1S71	2S71	0...32767

Technical Reference Manual - ANSI Version

Variable	Actual settings (R), channel 0	Group/Channel 1 (R, W, P)	Group/Channel 2 (R, W, P)	Setting range
Checksum, SGB 2	S72	1S72	2S72	0...32767
Checksum, SGB 3	S73 <sup>b)</sup>	1S73	2S73	0...32767
Checksum, SGB 4	S74 <sup>b)</sup>	1S74	2S74	0...32767
Checksum, SGB 5	S75 <sup>b)</sup>	1S75	2S75	0...32767
Checksum, SGR 1	S81	1S81	2S81	0...8191
Checksum, SGR 2	S82	1S82	2S82	0...8191
Checksum, SGR 3	S83	1S83	2S83	0...8191
Checksum, SGR 4	S84	1S84	2S84	0...8191
Checksum, SGR 5	S85	1S85	2S85	0...8191
Checksum, SGR 6	S86 <sup>c)</sup>	1S86	2S86	0...8191
Checksum, SGR 7	S87 <sup>c)</sup>	1S87	2S87	0...8191
Checksum, SGR 8	S88 <sup>c)</sup>	1S88	2S88	0...8191
Checksum, SGL 1	S91	1S91	2S91	0...16383
Checksum, SGL 2	S92	1S92	2S92	0...16383
Checksum, SGL 3	S93	1S93	2S93	0...16383
Checksum, SGL 4	S94	1S94	2S94	0...16383
Checksum, SGL 5	S95	1S95	2S95	0...16383
Checksum, SGL 6	S96	1S96	2S96	0...16383
Checksum, SGL 7	S97	1S97	2S97	0...16383
Checksum, SGL 8	S98	1S98	2S98	0...16383

<sup>a)</sup> If the protection element is out of operation, the number indicating the currently used value will be displaced by "999" when the parameter is read via the SPA bus and by dashes on the LCD.  
<sup>b)</sup> If the optional I/O module has not been installed, a dash will be shown on the LCD and "99999" when the parameter is read via the SPA bus.  
<sup>c)</sup> If the optional I/O module has not been installed, a dash will be shown on the LCD and "9999" when the parameter is read via the SPA bus.

**Recorded data**

Parameter V1 shows the element and phase which caused the trip or 27P-1 Alarm.  
 Parameter V2 shows the trip target code.

Parameters V3...V8 show the number of pickups of the protection elements,  
 parameters V9...V12 the number of trips of the protection elements.

**Table 5.1.17.-2 Recorded data: Channel 0**

Recorded data	Parameter (R)	Value
Element/phase which caused the trip	V1	1 = 59P-1 ( $U_{ca}$ ) 2 = 59P-1 ( $U_{bc}$ ) 4 = 59P-1 ( $U_{ab}$ ) 8 = 59N-1 16 = 59P-2 ( $U_{ca}$ ) 32 = 59P-2 ( $U_{bc}$ ) 64 = 59P-2 ( $U_{ab}$ ) 128 = 59N-2 256 = 27P-1 ( $U_{ca}$ ) 512 = 27P-1 ( $U_{bc}$ ) 1024 = 27P-1 ( $U_{ab}$ ) 2048 = 27P-2 ( $U_{ca}$ ) 4096 = 27P-2 ( $U_{bc}$ ) 8192 = 27P-2 ( $U_{ab}$ ) 16384 = 47 ( $U_2$ ) 32768 = 27D ( $U_1$ ) 65536 = External trip
Trip target code	V2	0 = - - - 1 = 59P-1 Pickup 2 = 59P-1 Trip 3 = 59P-2/47 Pickup 4 = 59P-2/47 Trip 5 = 27P-1 Pickup 6 = 27P-1 Trip 7 = 27P-2/27D Pickup 8 = 27P-2/27D Trip 9 = 59N-1 Pickup 10 = 59N-1 Trip 11 = 59N-2 Pickup 12 = 59N-2 Trip 13 = External Trip 14 = CBFAIL 15 = 27P-1 Alarm
Number of pickups of element 59P-1	V3	0...999
Number of pickups of element 59P-2/47	V4	0...999
Number of pickups of element 27P-1	V5	0...999
Number of pickups of element 27P-2/27D	V6	0...999
Number of pickups of element 59N-1	V7	0...999
Number of pickups of element 59N-2	V8	0...999
Number of trips of elements 59P-1 and 59P-2/47	V9	0...65535
Number of trips of elements 27P-1 and 27P-2/27D	V10	0...65535
Number of trips of	V11	0...65535
Number of external trips	V12	0...65535

The last five recorded values can be read with parameters V1...V18 on channels 1...5. Event n denotes the last recorded value, n-1 the next one, and so forth.

**Table 5.1.17.-3 Recorded data: Channels 1...5**

Recorded data	Event (R)					Value
	n Channel 1	n-1 Channel 2	n-2 Channel 3	n-3 Channel 4	n-4 Channel 5	
Phase-to-phase voltage $U_{ab}$	1V1	2V1	3V1	4V1	5V1	$0...2 \times U_n$ (VT)
Phase-to-phase voltage $U_{bc}$	1V2	2V2	3V2	4V2	5V2	$0...2 \times U_n$ (VT)
Phase-to-phase voltage $U_{ca}$	1V3	2V3	3V3	4V3	5V3	$0...2 \times U_n$ (VT)
Residual voltage $U_n$	1V4	2V4	3V4	4V4	5V4	$0...200\% U_n$ (VT)
Maximum pickup phase-to-phase voltage	1V5	2V5	3V5	4V5	5V5	$0...2 \times U_n$ (VT)
Minimum pickup phase-to-phase voltage	1V6	2V6	3V6	4V6	5V6	$0...2 \times U_n$ (VT)
Maximum pickup negative phase-sequence voltage $U_2$	1V7	2V7	3V7	4V7	5V7	$0...2 \times U_n$ (VT) <sup>a)</sup>
Minimum pickup positive phase-sequence voltage $U_1$	1V8	2V8	3V8	4V8	5V8	$0...2 \times U_n$ (VT) <sup>b)</sup>
Maximum residual voltage $U_n$	1V9	2V9	3V9	4V9	5V9	$0...200\% U_n$ (VT)
Pickup duration of element 59P-1	1V10	2V10	3V10	4V10	5V10	0...100%
Pickup duration of element 59P-2/47	1V11	2V11	3V11	4V11	5V11	0...100%
Pickup duration of element 27P-1	1V12	2V12	3V12	4V12	5V12	0...100%
Pickup duration of element 27P-2/27D	1V13	2V13	3V13	4V13	5V13	0...100%
Pickup duration of element 59N-1	1V14	2V14	3V14	4V14	5V14	0...100%
Pickup duration of element 59N-2	1V15	2V15	3V15	4V15	5V15	0...100%
Pickup duration of external trip	1V16	2V16	3V16	4V16	5V16	0/100%
Time stamp of the recorded data, date	1V17	2V17	3V17	4V17	5V17	YY-MM-DD
Time stamp of the recorded data, time	1V18	2V18	3V18	4V18	5V18	HH.MM;SS.sss

<sup>a)</sup> If is not based on negative phase-sequence voltage  $U_2$ , dashes are shown on the LCD and "999" when read via serial communication.

<sup>b)</sup> If is not based on positive phase-sequence voltage  $U_1$ , dashes are shown on the LCD and "999" when read via serial communication.

## Disturbance recorder

**Table 5.1.17.-4 Parameters for the disturbance recorder**

Description	Parameter (channel 0)	R, W	Value
Remote triggering	M1 <sup>a)</sup>	W	1
Clear recorder memory	M2	W	1
Sampling rate	M15 <sup>b)</sup>	R, W	800/960 Hz 400/480 Hz 50/60 Hz
Station identification/unit number	M18	R, W	0...9999
Rated frequency	M19	R	50 or 60 Hz
Name of the station	M20	R, W	Max 16 characters
Digital channel texts	M40...M47	R	-
Analog channel texts	M60...M63	R	-
Analog channel conversion factor and unit for primary voltage transformer(s)	M80 <sup>c)</sup> <sup>d)</sup>	R, W	Factor 0.00...600, unit (V, kV), e.g. 20.0,kV
	M81 and M82	R R	
Analog channel conversion factor and unit for residual voltage $U_n$	M83 <sup>c)</sup>	R, W	Factor 0.00...600, unit (V, kV), e.g. 20.0,kV
Internal trigger signals' checksum	V236	R, W	0...4095
Internal trigger signal's edge	V237	R, W	0...4095
Checksum of internal signal storing mask	V238 <sup>b)</sup>	R, W	0...4095
Post-triggering recording length	V240	R, W	0...100%
External trigger signal's checksum	V241	R, W	0...31
External trigger signal's edge	V242	R, W	0...31
Checksum of external signal storing mask	V243 <sup>b)</sup>	R, W	0...31
Triggering state, clearing and restart	V246	R, W	R: 0 = Recorder not triggered 1 = Recorder triggered and recording stored in the memory W: 0 = Clear recorder memory 2 = Download restart; sets the first information and the time stamp for triggering ready to be read 4 = Manual triggering

<sup>a)</sup> M1 can be used for broadcast triggering by using the unit address "900".

<sup>b)</sup> Parameters can be written if the recorder has not been triggered.

<sup>c)</sup> The disturbance recorder requires this parameter to be set. The conversion factor is the transformation ratio multiplied by the rated of the relay. If this parameter is set to zero, the disturbance recorder data cannot be analyzed and dashes are shown on the LCD instead of the primary values.

<sup>d)</sup> This value is copied to parameters M81 and M82.

**Table 5.1.17.-5 Disturbance recorder internal triggering and storing**

Event	Weighting factor	Default value of triggering mask, V236	Default value of triggering edge, V237 <sup>a)</sup>	Default value of storing mask, V238
Pickup of element 59P-1	1	0	0	0
Trip of element 59P-1	2	1	0	1
Pickup of element 59P-2 or 47	4	0	0	1
Trip of element 59P-2 or 47	8	1	0	1
Pickup of element 27P-1	16	0	0	0
Trip of element 27P-1	32	1	0	1
Pickup of element 27P-2 or 27D	64	0	0	1
Trip of element 27P-2 or 27D	128	1	0	1
Pickup of element 59N-1	256	0	0	0
Trip of element 59N-1	512	1	0	1
Pickup of element 59N-2	1024	0	0	0
Trip of element 59N-2	2048	1	0	0
Σ		682	0	751

<sup>a)</sup> 0 = rising edge; 1 = falling edge.

**Table 5.1.17.-6 Disturbance recorder external triggering and storing**

Event	Weighting factor	Default value of triggering mask, V241	Default value of triggering edge, V242 <sup>a)</sup>	Default value of storing mask, V243
DI1	1	0	0	0
DI2	2	0	0	0
DI3	4	0	0	0
DI4	8	0	0	0
DI5	16	0	0	0
Σ		0	0	0

<sup>a)</sup> 0 = rising edge; 1 = falling edge.

**Table 5.1.17.-7 Control parameters**

Description	Parameter	R, W, P	Value
Reading of the event buffer	L	R	Time, channel number and event code
Re-reading of the event buffer	B	R	Time, channel number and event code
Reading of relay state data	C	R	0 = Normal state 1 = The relay has been subject to an automatic reset 2 = Overflow of the event buffer 3 = Both 1 and 2

## Technical Reference Manual - ANSI Version

Description	Parameter	R, W, P	Value
Resetting of relay state data	C	W	0 = Reset E50 and E51 1 = Reset only E50 2 = Reset only E51 4 = Reset all events including E51 except for E50
Time reading and setting	T	R, W	SS.sss
Date and time reading and setting	D	R, W	YY-MM-DD HH.MM;SS.sss
Type designation of the relay	F	R	REU610
Unlatching output contacts	V101	W	1 = Unlatch
Clearing targets and memorized values and unlatching contacts (master reset)	V102	W	1 = Clear and unlatch
Resetting of trip lockout	V103	W	1 = Reset
Rated frequency	V104	R, W (P)	50 or 60 Hz
Time setting range for demand values in minutes	V105	R, W	0...999 min
Non-volatile memory settings	V106	R, W	0...31
Time setting for disabling new trip targets on the LCD	V108	R, W (P)	0...999 min
Testing the self-supervision	V109	W (P)	1 = Self-supervision output contact is activated and the READY target LED starts to flash 0 = Normal operation
LED test for pickup and trip targets	V110	W (P)	0 = Pickup and trip LEDs off 1 = Trip LED on, pickup LED off 2 = Pickup LED on, trip LED off 3 = and trip LEDs on
LED test for programmable LEDs	V111	W (P)	0...255
Trip-circuit supervision	V113	R, W	0 = Not in use 1 = In use
Store counter <sup>a)</sup>	V114	R	0...65535
Nominal voltage	V134	R, W (P)	0 = 100 V 1 = 110 V 2 = 115 V 3 = 120 V
Remote control of setting group	V150	R, W	0 = Setting group 1 1 = Setting group 2
Event mask for E31...E34	V155	R, W	0...63
Event mask for 1E1...1E16	1V155	R, W	0...65535
Event mask for 1E17...1E24	1V156	R, W	0...255
Event mask for 1E25...1E30	1V157	R, W	0...63
Event mask for 2E1...2E16	2V155	R, W	0...65535
Event mask for 2E17...2E26	2V156	R, W	0...1023
Entering the SPA password for settings	V160	W	1...999
Changing the SPA password or taking the password protection into use	V161	W (P)	1...999
Changing the HMI Setting password	V162	W	1...999
Changing the HMI Communication password	V163	W	1...999

Technical Reference Manual - ANSI Version

Description	Parameter	R, W, P	Value
Clearing trip counters 59P-1 and 59P-2; 27P-1 and 27P-2; 59N-1 and 59N-2; External trips	V166	W (P)	1 = Clear trip counters
Restoring factory settings	V167	W (P)	2 = Restore factory settings for CPU 3 = Restore factory settings for DNP
Warning code	V168	R	0...63 <sup>b)</sup>
IRF code	V169	R	0...255 <sup>b)</sup>
Unit address of the relay	V200	R, W	1...254
Data transfer rate (SPA), kbps	V201	R, W	9.6/4.8
Rear communication	V202	W	1 = Rear connector activated
Rear communication protocol	V203 <sup>c)</sup>	R, W	0 = SPA 1 = IEC_103 2 = Modbus RTU 3 = Modbus ASCII 4 = DNP 3.0 (read-only)
Connection type	V204	R, W	0 = Loop 1 = Star
Line-idle state	V205	R, W	0 = Light off 1 = Light on
Optional communication module	V206	R, W (P)	0 = Not in use 1 = In use <sup>d)</sup>
HMI language set information	V226	R	00...99
CPU software number	V227	R	1MRS118513
CPU software revision	V228	R	A...Z
CPU build number	V229	R	XXX
DNP protocol name	2V226	R	DNP 3.0
DNP software number	2V227	R	1MRS118531
DNP software revision	2V228	R	A...Z
DNP build number	2V229	R	XXX
Relay serial number	V230	R	BAxxxxxx
CPU serial number	V231	R	ACxxxxxx
DNP serial number	V232	R	AKxxxxxx
Test date	V235	R	YYMMDD
Date reading and setting	V250	R, W	YY-MM-DD
Time reading and setting	V251	R, W	HH.MM;SS.sss

- a) The store counter can be used for monitoring parameter changes, for instance. The store counter is incremented by one on each parameter change via the HMI or serial communication. When the counter reaches its maximum value, it will roll over. If the factory settings are restored, the counter is cleared.
- b) In case of a warning, the value 255 is stored in V169. This enables the master to continuously read only V169.
- c) If the optional DNP 3.0 module has been installed, the DNP 3.0 communication protocol is automatically selected.
- d) If the optional communication module is not installed, a warning of a faulty communication module appears on the LCD together with the fault code.

The measured voltages can be read with parameters I1...I4, the positive phase-sequence voltage with parameter I5, the negative phase-sequence voltage with parameter I6 and the status of the digital inputs with parameters I7...I11.

**Table 5.1.17.-8 Input signals**

Description	Channel	Parameter (R)	Value
Measured phase-to-phase voltage $U_{ab}$	0	I1	$0...2 \times U_n$ (VT)
Measured phase-to-phase voltage $U_{bc}$	0	I2	$0...2 \times U_n$ (VT)
Measured phase-to-phase voltage $U_{ca}$	0	I3	$0...2 \times U_n$ (VT)
Measured phase-to-phase voltage $U_n$	0	I4	$0...200\%$ $U_n$ (VT)
Calculated positive phase-sequence voltage	0	I5	$0...2 \times U_n$ (VT)
Calculated negative phase-sequence voltage	0	I6	$0...2 \times U_n$ (VT)
DI1 status	0,2	I7	$0/2^{a)}$
DI2 status	0,2	I8	$0/2^{a)}$
DI3 status	0,2	I9	$0/2^{a)b)}$
DI4 status	0,2	I10	$0/2^{a)b)}$
DI5 status	0,2	I11	$0/2^{a)b)}$

a) When the value is 1, the digital input is energized.

b) If the optional I/O module has not been installed, a dash is shown on the LCD and "9" when the parameter is read via the SPA bus.

Each protection element has its internal output signal. These signals can be read with parameters O1...O15 and the recorded functions with parameters O61...O75. The state of the output contacts can be read or changed with parameters O41...O49 and the recorded functions read with parameters O101...O109.

**Table 5.1.17.-9 Output signals**

Status of the protection elements	Channel	State of element (R)	Recorded functions (R)	Value
Pickup of element 59P-1	0,1	O1	O61	0/1
Trip of element 59P-1	0,1	O2	O62	0/1
Pickup of element 59P-2 or 47	0,1	O3	O63	0/1
Trip of element 59P-2 or 47	0,1	O4	O64	0/1
Pickup of element 27P-1	0,1	O5	O65	0/1
Trip of element 27P-1	0,1	O6	O66	0/1 ;
Pickup of element 27P-2 or 27D	0,1	O7	O67	0/1
Trip of element	0,1	O8	O68	0/1
Pickup of element 59N-1	0,1	O9	O69	0/1
Trip of element 59N-1	0,1	O10	O70	0/1

Status of the protection elements	Channel	State of element (R)	Recorded functions (R)	Value
Pickup of element 59N-2	0,1	O11	O71	0/1
Trip of element 59N-2	0,1	O12	O72	0/1
External trip	0,1	O13	O73	0/1
Trip lockout	0,1	O14	O74	0/1
CBFAIL trip	0,1	O15	O75	0/1

**Table 5.1.17.-10 Outputs**

Operation of output contact	Channel	State of output (R, W, P)	Recorded functions (R)	Value
Output PO1	0,2	O41	O101	0/1
Output PO2	0,2	O42	O102	0/1
Output PO3 <sup>a)</sup>	0,2	O43	O103	0/1 <sup>b)</sup>
Output SO1	0,2	O44	O104	0/1
Output SO2	0,2	O45	O105	0/1
Output PO3 (trip lockout) <sup>c)</sup>	0,2	O46	-	0/1 <sup>b)</sup>
Output SO3	0,2	O47	O107	0/1 <sup>d)</sup>
Output SO4	0,2	O48	O108	0/1 <sup>d)</sup>
Output SO5	0,2	O49	O109	0/1 <sup>d)</sup>
Enabling activation of output contacts PO1, PO2, PO3, SO1, SO2, SO3, SO4 and SO5 via the SPA bus	0,2	O51	-	0/1

<sup>a)</sup> State of output when the trip lockout function is not in use.

<sup>b)</sup> Either O43/O103 or O46 is to be used at a time.

<sup>c)</sup> State of output when the trip lockout function is in use.

<sup>d)</sup> If the optional I/O module has not been installed, a dash is shown on the LCD and "9" when the parameter is read via the SPA bus.



Parameters O41...O49 and O51 control the physical output contacts which can be connected to circuit breakers, for instance.

### Parameters for IEC 60870-5-103 remote communication protocol

**Table 5.1.17.-11 Settings**

Description	Parameter (channel 507)	R, W, P	Value
Unit address of the relay	507V200	R, W	1...254
Data transfer rate (IEC 60870-5-103), kbps	507V201	R, W (P)	9.6/4.8

### Parameters for Modbus remote communication protocol

**Table 5.1.17.-12 Settings**

Description	Parameter (channel 504)	R, W, P	Value
User-defined register 1	504V1	R, W	0...65535 <sup>a)</sup>
User-defined register 2	504V2	R, W	0...65535 <sup>a)</sup>
User-defined register 3	504V3	R, W	0...65535 <sup>a)</sup>
User-defined register 4	504V4	R, W	0...65535 <sup>a)</sup>
User-defined register 5	504V5	R, W	0...65535 <sup>a)</sup>
User-defined register 6	504V6	R, W	0...65535 <sup>a)</sup>
User-defined register 7	504V7	R, W	0...65535 <sup>a)</sup>
User-defined register 8	504V8	R, W	0...65535 <sup>a)</sup>
User-defined register 9	504V9	R, W	0...65535 <sup>a)</sup>
User-defined register 10	504V10	R, W	0...65535 <sup>a)</sup>
User-defined register 11	504V11	R, W	0...65535 <sup>a)</sup>
User-defined register 12	504V12	R, W	0...65535 <sup>a)</sup>
User-defined register 13	504V13	R, W	0...65535 <sup>a)</sup>
User-defined register 14	504V14	R, W	0...65535 <sup>a)</sup>
User-defined register 15	504V15	R, W	0...65535 <sup>a)</sup>
User-defined register 16	504V16	R, W	0...65535 <sup>a)</sup>
Unit address of the relay	504V200	R, W	1...254
Data transfer rate (Modbus), kbps	504V201	R, W	9.6/4.8/2.4/1.2/0.3
Modbus link parity	504V220	R, W	0 = even 1 = odd 2 = no parity
CRC order of Modbus RTU link	504V221	R, W	0 = low/high 1 = high/low

<sup>a)</sup> The default value is 0.

### Parameters for DNP 3.0 remote communication protocol

**Table 5.1.17.-13 Settings**

Description	SPA parameter (channel 503)	R, W	Value range	Default	Explanation
Unit address	503V1	R, W	0...65532	1	Address of the relay in the DNP 3.0 network
Master address	503V2	R, W	0...65532	2	Address of the master station (destination address for unsolicited responses)
Primary data link timeout	503V3	R, W	0 = no data link timeout used 1...65535 ms	0	Used when the relay sends data using service 3
Primary data link layer retransmission count	503V4	R, W	0...255	0	Number of retransmissions on data link layer
Application layer confirmation timeout	503V6	R, W	0...65535 ms	5000	Used when the relay sends messages with confirmation request
Application layer retransmission count	503V7	R, W	0...255	0	Number of retransmissions on the application layer when the relay sends messages with confirmation request
Confirmation on application layer	503V9	R, W	0 = enabled only for event messages 1 = enabled for all messages	0	Used to enforce inclusion of confirmation request in all application messages (DNP 3.0 standard requires inclusion of confirmation request in event messages only)
Default variation of binary input objects	503V10	R, W	1...2	2	
Default variation of binary input change event objects	503V11	R, W	1...2	2	
Default variation of analog input objects	503V15	R, W	1...4	2	
Default variation of analog input change event objects	503V16	R, W	1...4	2	
Default variation of counter objects	503V13	R, W	1...2	2	
Default variation of counter change event objects	503V14	R, W	1, 2, 5, 6	2	
Default variation of frozen counter objects	503V30	R, W	1, 2, 5, 6	2	
Class 1 event delay	503V18	R, W	0...255 s	0	
Class 1 event count	503V19	R, W	0...255	1	
Class 2 event delay	503V20	R, W	0...255 s	0	
Class 2 event count	503V21	R, W	0...255	1	
Class 3 event delay	503V22	R, W	0...255 s	0	
Class 3 event count	503V23	R, W	0...255	1	
Unsolicited reporting mode	503V24	R, W	0 = UR disabled 1 = immediate 2 = empty UR 3 = empty UR and enable UR	0	Refer to Unsolicited reporting pick up in Section 5.1.16.4. Specific DNP features.

Description	SPA parameter (channel 503)	R, W	Value range	Default	Explanation
Scaling factor 1	503V101	R, W	0...4294967295	1	
Scaling factor 2	503V102	R, W	0...4294967295	1	
Scaling factor 3	503V103	R, W	0...4294967295	1	
Scaling factor 4	503V104	R, W	0...4294967295	1	
Scaling factor 5	503V105	R, W	0...4294967295	1	
Baud rate	503V211	R, W	4.8/9.6/19.2/38.4	9.6	
Number of stop bits	503V212	R, W	1...2	1	
Parity	503V230	R, W	0 = no parity 1 = odd 2 = even	0	
Silent interval	503V232	R, W	0...65535 ms	20	
Time slot width	503V233	R, W	0...255 ms	10	
Number of time slots	503V234	R, W	0...255	8	
Collision detection enabled	503V235	R, W	0 = disabled 1 = enabled	0	
DNP module warning register	503V168	R	Bit coded 0 = OK		
DNP module status register	503V169	R	Bit coded 0 = OK		

## Measurements

**Table 5.1.17.-14 Measured values**

Description	Parameter (channel 0)	R, W, P	Value
One-minute average voltage value	V61	R	$0...2 \times U_n$ (VT) <sup>a)</sup>
Average voltage value during the specified time range	V62	R	$0...2 \times U_n$ (VT) <sup>a)</sup>
Maximum one-minute average voltage value during the specified time range	V63	R	$0...2 \times U_n$ (VT) <sup>a)</sup>
Maximum voltage of the three phase-to-phase voltages since last reset	V64	R	$0...2 \times U_n$ (VT)
Date of maximum voltage	V65	R	YY-MM-DD
Time of maximum voltage	V66	R	hh.mm;ss.sss
Minimum voltage of three phase-to-phase voltages since last reset	V67	R	$0...2 \times U_n$ (VT)
Date of minimum voltage	V68	R	YY-MM-DD
Time of minimum voltage	V69	R	hh.mm;ss.sss

<sup>a)</sup> If the demand value is reset and the specified time has not elapsed, dashes are shown on the LCD and "999" when the parameter is read via the SPA bus.

### 5.1.17.1.

## Event codes

Special codes are determined to represent certain events, such as pickup and tripping of protection elements and different states of output signals.

The events are stored in the event buffer of the relay. The maximum capacity of the buffer is 100 events. Under normal conditions the buffer is empty.

The contents of the buffer can be read using the L command, 5 events at a time. Using the L command erases the previously read events from the buffer, with the exception of events E50 and E51 which have to be reset by using the C command. If a fault occurs and reading fails for example in data communication, the events can be re-read by using the B command. If needed, the B command can also be repeated.

The L and B commands are only available on channel 0.

Events to be included in the event reporting are marked with the multiplier 1. The event mask is formed by the sum of the weighting factors of all those events which are to be included in event reporting.

**Table 5.1.17.1-1 Event masks**

Event mask	Code	Setting range	Default setting
V155	E31...E36	0...63	1
1V155	1E1...1E16	0...65535	21845
1V156	1E17...1E24	0...255	85
1V157	1E25...1E30	0...63	1
2V155	2E1...2E16	0...65535	3
2V156	2E17...2E26	0...1023	0

**Channel 0**

Events always included in the event reporting:

**Table 5.1.17.1-2 Event codes E1...E4**

Channel	Event	Description
0	E1	IRF
0	E2	IRF disappeared
0	E3	Warning
0	E4	Warning disappeared

**Table 5.1.17.1-3 Event codes E50...E51**

Channel	Event	Description
0	E50	Relay restart
0	E51	Event buffer overflow

Events possible to mask out:

**Table 5.1.17.1-4 Event codes E31...E36**

Channel	Event	Description	Weighting factor	Default value
0	E31	Disturbance recorder triggered	1	1
0	E32	Disturbance recorder memory cleared	2	0
0	E33	HMI Setting password opened	4	0
0	E34	HMI Setting password closed	8	0
0	E35	HMI Communication password opened	16	0
0	E36	HMI Communication password closed	32	0
Default value of event mask V155				1

**Channel 1****Table 5.1.17.1-5 Event codes E1...E16**

Channel	Event	Description	Weighting factor	Default value
1	E1	Pickup signal from element 59P-1 activated	1	1
1	E2	Pickup signal from element 59P-1 reset	2	0
1	E3	Trip signal from element 59P-1 activated	4	1
1	E4	Trip signal from element 59P-1 reset	8	0
1	E5	Pickup signal from element 59P-2 or 47 activated	16	1
1	E6	Pickup signal from element 59P-2 or 47 reset	32	0
1	E7	Trip signal from element 59P-2 or 47 activated	64	1
1	E8	Trip signal from element 59P-2 or 47 reset	128	0
1	E9	Pickup signal from element 27P-1 activated	256	1
1	E10	Pickup signal from element 27P-1 reset	512	0
1	E11	Trip signal from element 27P-1 activated	1024	1
1	E12	Trip signal from element 27P-1 reset	2048	0
1	E13	Pickup signal from element 27P-2 or 27D activated	4096	1
1	E14	Pickup signal from element 27P-2 or 27D reset	8192	0
1	E15	Trip signal from element 27P-2 or 27D activated	16384	1
1	E16	Trip signal from element 27P-2 or 27D reset	32768	0
Default value of event mask 1V155				21845

**Table 5.1.17.1-6 Event codes E17...E24**

Channel	Event	Description	Weighting factor	Default value
1	E17	Pickup signal from element 59N-1 activated	1	1
1	E18	Pickup signal from element 59N-1 reset	2	0
1	E19	Trip signal from element 59N-1 activated	4	1
1	E20	Trip signal from element 59N-2 reset	8	0
1	E21	Pickup signal from element 59N-2 activated	16	1

Channel	Event	Description	Weighting factor	Default value
1	E22	Pickup signal from element 59N-2 reset	32	0
1	E23	Trip signal from element 59N-2 activated	64	1
1	E24	Trip signal from element 59N-2 reset	128	0
Default value of event mask 1V156				85

**Table 5.1.17.1-7 Event codes E25...E30**

Channel	Event	Description	Weighting factor	Default value
1	E25	Trip lockout activated	1	1
1	E26	Trip lockout reset	2	0
1	E27	External trip activated	4	0
1	E28	External trip reset	8	0
1	E29	CBFAIL activated	16	0
1	E30	CBFAIL reset	32	0
Default value of event mask 1V157				1

**Channel 2**

**Table 5.1.17.1-8 Event codes E1...E16**

Channel	Event	Description	Weighting factor	Default value
2	E1	PO1 activated	1	1
2	E2	PO1 reset	2	1
2	E3	PO2 activated	4	0
2	E4	PO2 reset	8	0
2	E5	PO3 activated	16	0
2	E6	PO3 reset	32	0
2	E7	SO1 activated	64	0
2	E8	SO1 reset	128	0
2	E9	SO2 activated	256	0
2	E10	SO2 reset	512	0
2	E11	SO3 activated	1024	0
2	E12	SO3 reset	2048	0
2	E13	SO4 activated	4096	0
2	E14	SO4 reset	8192	0
2	E15	SO5 activated	16384	0
2	E16	SO5 reset	32768	0
Default value of event mask 2V155				3

**Table 5.1.17.1.-9 Event codes E17...E26**

Channel	Event	Description	Weighting factor	Default value
2	E17	DI1 activated	1	0
2	E18	DI1 deactivated	2	0
2	E19	DI2 activated	4	0
2	E20	DI2 deactivated	8	0
2	E21	DI3 activated	16	0
2	E22	DI3 deactivated	32	0
2	E23	DI4 activated	64	0
2	E24	DI4 deactivated	128	0
2	E25	DI5 activated	256	0
2	E26	DI5 deactivated	512	0
Default value of event mask 2V156				0

**5.1.18.****Self-supervision (IRF) system**

The relay is provided with an extensive self-supervision system which continuously supervises the software and the electronics of the relay. It handles run-time fault situations and informs the user about an existing fault via a LED on the HMI and a text message on the LCD. The fault codes can also be read via serial communication. There are two types of fault targets: IRF targets and warnings.

**Internal relay fault**

When an internal relay fault preventing relay operation is detected, the relay first tries to eliminate the fault by restarting. Only after the fault is found to be permanent, the green target LED (ready) begins to flash and the self-supervision output contact is activated. All other output contacts are returned to the initial state and locked for the internal relay fault. Further, a fault target message appears on the LCD, including a fault code.

IRF targets have the highest priority on the HMI. None of the other HMI targets can override the IRF target. As long as the green target LED (ready) is flashing, the fault target cannot be cleared. In case an internal fault disappears, the green target LED (ready) stops flashing and the relay is returned to the normal service state, but the fault target message remains on the LCD until manually cleared.

The IRF code indicates the type of internal relay fault. When a fault appears, the code is to be recorded and stated when ordering service. The fault codes are listed in the following table:

**Table 5.1.18.-1 IRF codes**

Fault code	Type of fault
4	Error in output relay PO1
5	Error in output relay PO2
6	Error in output relay PO3
7	Error in output relay SO1
8	Error in output relay SO2
9	Error in the enable signal for output relay PO1, PO2, SO1 or SO2
10, 11, 12	Error in the feedback, enable signal or output relay PO1, PO2, SO1 or SO2
13	Error in optional output relay SO3
14	Error in optional output relay SO4
15	Error in optional output relay SO5
16	Error in the enable signal for optional output relay SO3, SO4 or SO5
17, 18, 19	Error in the feedback, enable signal or optional output relay SO3, SO4 or SO5
20, 21	Auxiliary voltage dip
30	Faulty program memory
50, 59	Faulty work memory
51, 52, 53 <sup>a)</sup> , 54, 56	Faulty parameter memory <sup>b)</sup>
55	Faulty parameter memory, calibration parameters
80	Optional I/O module missing
81	Optional I/O module unknown
82	Optional I/O module configuration error
85	Power supply module faulty
86	Power supply module unknown
90	Hardware configuration error
95	Communication module unknown
104	Faulty configuration set (for IEC 60870-5-103)
131, 139, 195, 203, 222, 223	Internal reference voltage error
253	Error in the measuring unit

<sup>a)</sup> Can be corrected by restoring factory settings for CPU.

<sup>b)</sup> All settings will be zero during the fault.

For further information on internal relay faults, refer to the Operator’s Manual.

**Warnings**

In case of a warning, the relay continues to operate except for those protection functions possibly affected by the fault, and the green target LED (ready) remains lit as during normal operation. Further, a fault target message, which depending on the type of fault includes a fault code, appears on the LCD. If more than one type of fault occur at the same time, one single numeric code which indicates all the faults is displayed. The fault target message cannot be manually cleared but it disappears with the fault.

When a fault appears, the fault target message is to be recorded and stated when ordering service. The fault codes are listed in the following table:

**Table 5.1.18.-2 Warning codes**

Fault	Weight value
Battery low	1
Trip-circuit supervision <sup>a)</sup>	2
Power supply module temperature high	4
Communication module faulty or missing	8
DNP 3.0 configuration error <sup>b)</sup>	16
DNP 3.0 module faulty	32
$\Sigma$	63

<sup>a)</sup> The external fault warning can be routed to SO2 with SGF1/8.

<sup>b)</sup> Can be corrected by restoring factory settings for DNP

For further information on warnings, refer to the Operator's Manual.

## 5.1.19. Relay parameterization

The parameters of the relay can be set either locally via the HMI or externally via serial communication with Relay Setting Tool.

### Local parameterization

When the parameters are set locally, the setting parameters can be chosen via the hierarchical menu structure. The wanted language can be selected for parameter descriptions. Refer to the Operator's Manual for further information.

### External parameterization

Relay Setting Tool is used for parameterizing the relay units. Adjusting the parameter values using Relay Setting Tool is done off-line, after which the parameters can be downloaded to the relay via a communication port.

## 5.2. Design description

### 5.2.1. Input/output connections

All external circuits are connected to the terminals on the rear panel of the relay.

- Terminals X2.1-   are dimensioned for one 0.5...6.0 mm<sup>2</sup> (AWG 20-8) wire or two max 2.5 mm<sup>2</sup> (AWG 24-12) wires
- Terminals X3.1-   and X4.1-   are dimensioned for one 0.2...2.5 mm<sup>2</sup> wire or two 0.2...1.0 mm<sup>2</sup> (AWG 24-16) wires.

The energizing phase-to-phase voltages of the relay are connected to terminals:

- X2.1/1-2
- X2.1/3-4
- X2.1/5-6

For inputs for phase-to-phase voltages and residual voltage, refer to Table 5.2.1.-1.



The relay can also be used in single or two-phase applications by leaving one or two energizing inputs unoccupied. However, at least terminals X2.1/1-2 must be connected.

The energizing residual voltage of the relay is connected to terminals X2.1/7-8, see Table 5.2.1.-1.

The input terminals of the optional I/O module are located on connection socket X3.1, see Table 5.2.1.-4 and Table 5.2.1.-5.



When connection socket X3.1 is used, the optional I/O module must be installed.



The nominal voltage (100/110/115/120 V) of the matching transformers has to be selected with SPA parameter V134.

Terminals X4.1/21-24 and X3.1/1-6 (optional) are digital input terminals, see Table 5.2.1.-5. The digital inputs can be used to generate a blocking signal, to unlatch output contacts or for remote control of relay settings, for instance. The requested functions are selected separately for each input in switchgroups SGB1...5. The digital inputs can also be used to trigger the disturbance recorder; this function is selected with SPA parameter V243.

The auxiliary voltage of the relay is connected to terminals X4.1/1-2, see Table 5.2.1.-2. At DC supply, the positive lead is connected to terminal X4.1/1. The permitted auxiliary voltage range of the relay is marked on the front panel of the relay under the handle of the plug-in unit.

Output contacts PO1, PO2 and PO3 are heavy-duty trip contacts capable of controlling most circuit breakers, see Table 5.2.1.-4. The signals to be routed to PO1...PO3 are selected with the switches of switchgroups SGR1...SGR3. On delivery from the factory, the trip signals from all the protection elements are routed to PO1, PO2 and PO3.

Output contacts SO1...SO5 can be used for signalling on pickup and tripping of the relay, see Table 5.2.1.-4. Output contacts SO3...SO5 are optional and available only if the optional I/O module has been installed. The signals to be routed to SO1...SO5

are selected with the switches of switchgroups SGR4...SGR8. On delivery from the factory, the pickup and alarm signals from all the protection elements are routed to SO1 and SO2.

The IRF contact functions as an output contact for the self-supervision system of the voltage relay, see Table 5.2.1.-3. Under normal operating conditions, the relay is energized and the contact is closed (X4.1/3-5). When a fault is detected by the self-supervision system or the auxiliary voltage is disconnected, the output contact drops off and the contact closes (X4.1/3-4).

Fig. 5.2.1.-1...Fig. 5.2.1.-3 present a rear view of the relay, showing four connecting sockets: one for measuring transformers, one for the optional I/O module, one for power supply and one for optional serial communication.

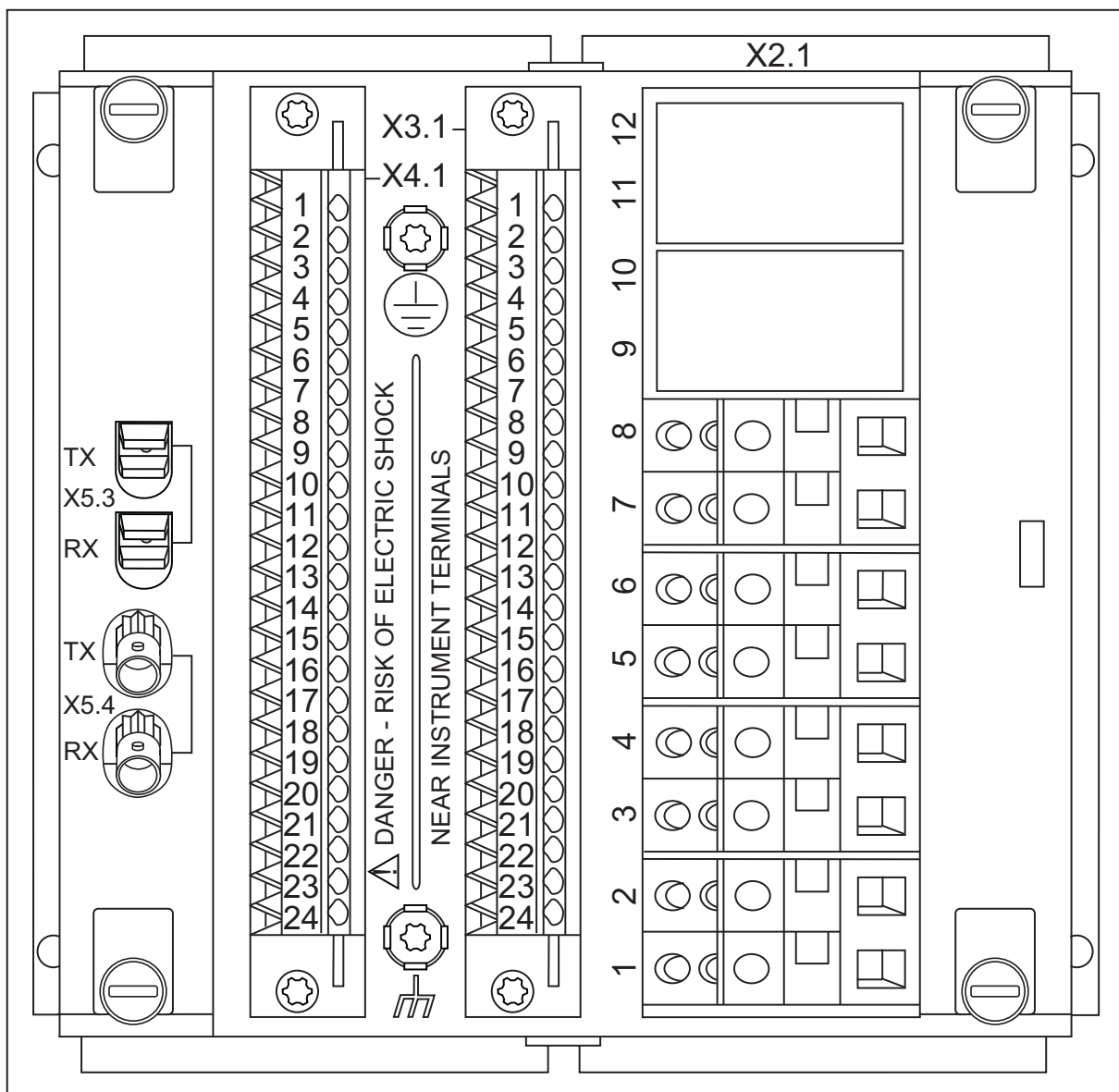

A051555

Fig. 5.2.1.-1 Rear view of the relay with the fibre-optic communication module for plastic and glass fibre

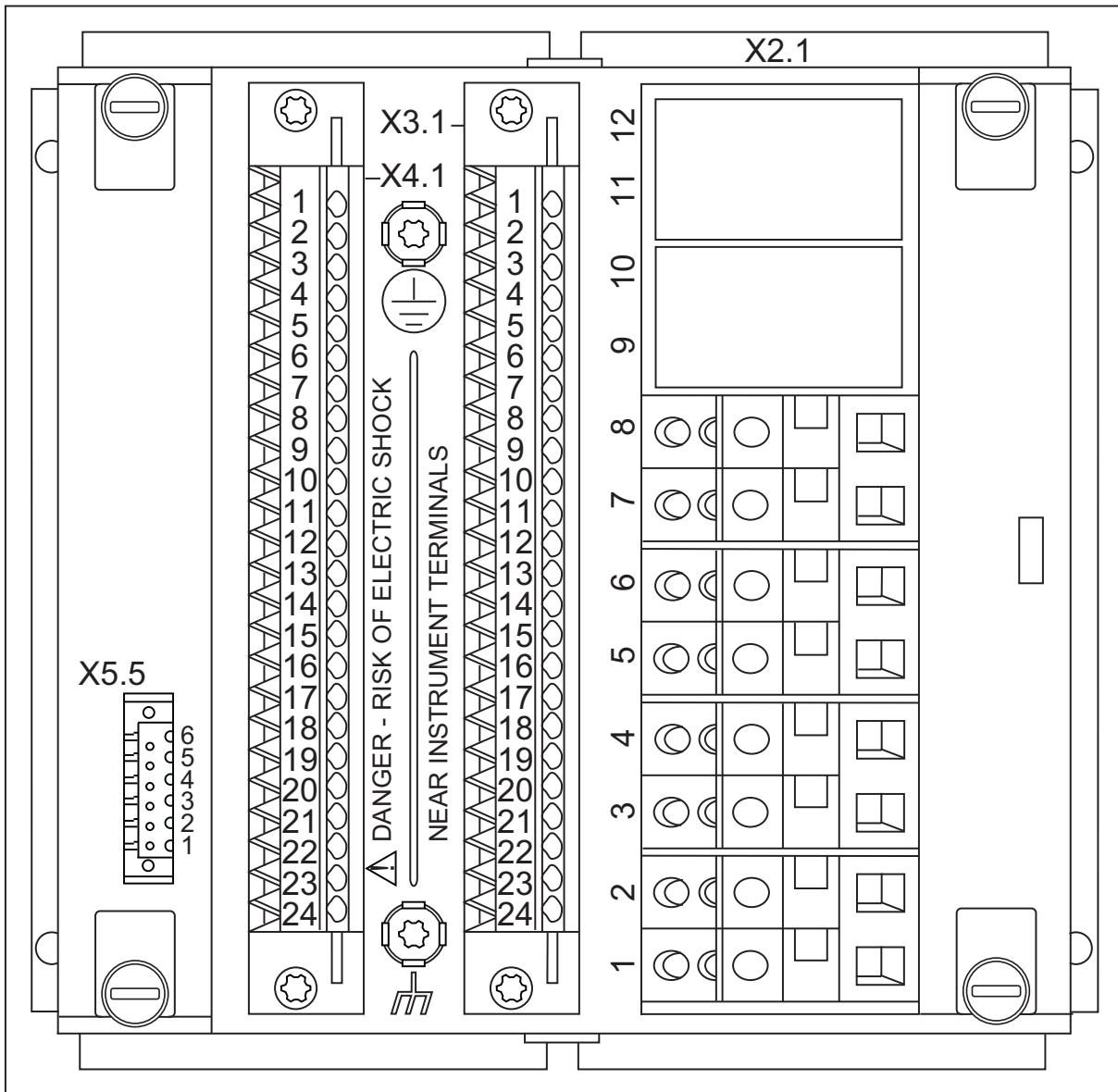
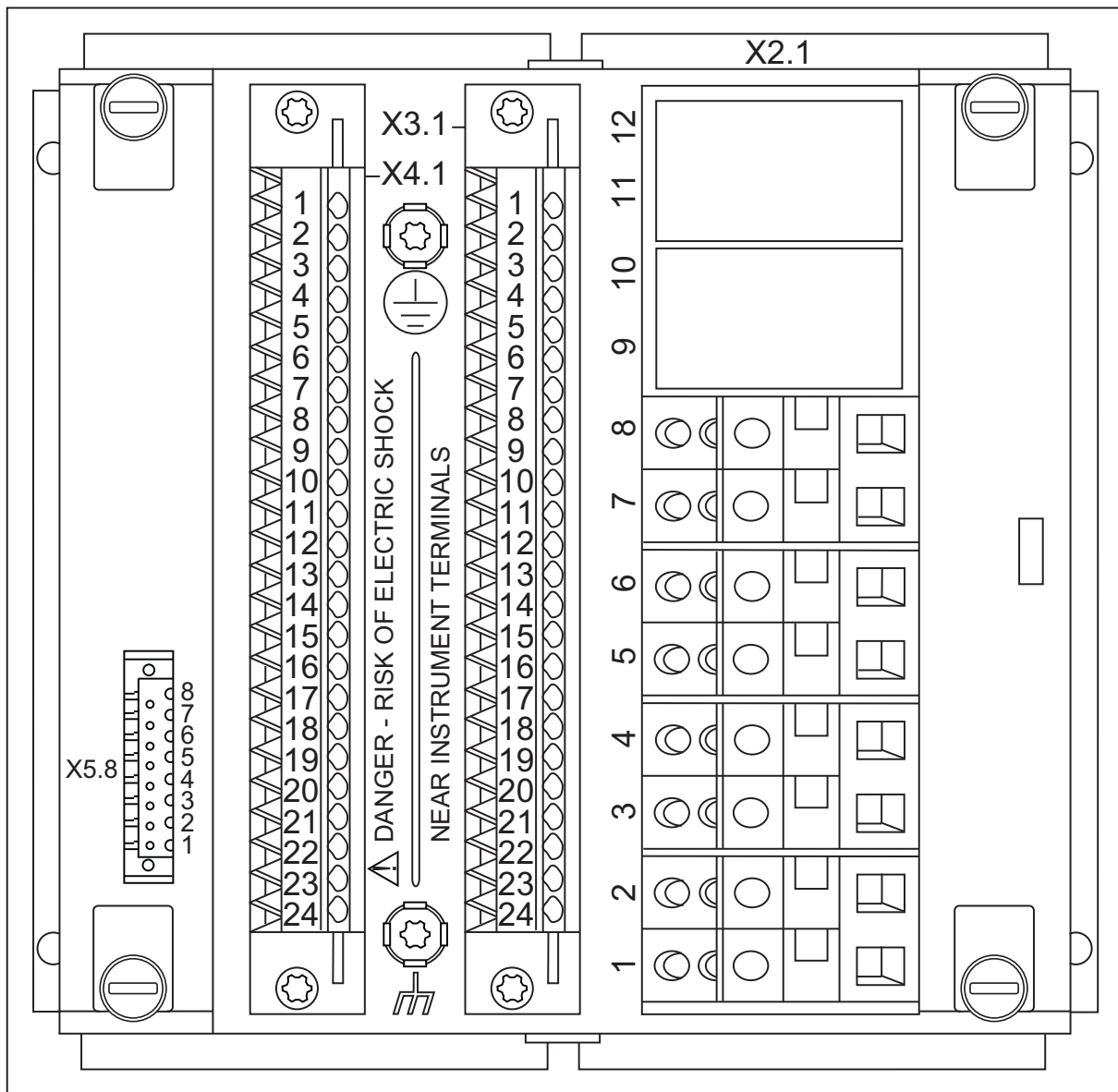

Fig. 5.2.1.-2 Rear view of the relay with the RS-485 communication module

A040187



A040189

Fig. 5.2.1.-3 Rear view of the relay with the DNP 3.0 communication module for RS-485



The wiring of  $U_{ab}$ ,  $U_{bc}$ , and  $U_{ca}$  has to be done identically for each of the matching transformer used.

**Table 5.2.1.-1 Inputs for phase-to-phase voltages and residual voltage**

Terminal	Function
	<b>REU610AVVxxxx</b>
X2.1-1 X2.1-2	$U_{ab}$

Terminal	Function
	<b>REU610AVVxxxx</b>
X2.1-3 X2.1-4	$U_{bc}$
X2.1-5 X2.1-6	$U_{ca}$
X2.1-7 X2.1-8	$U_n$



The wiring of  $U_{ab}$ ,  $U_{bc}$  and  $U_{ca}$  has to be done identically for each of the matching transformer used.

**Table 5.2.1.-2 Auxiliary supply voltage**

Terminal	Function
X4.1-1	Input, +
X4.1-2	Input, -

**Table 5.2.1.-3 IRF contact**

Terminal	Function
X4.1-3	IRF, common
X4.1-4	Closed; IRF, or $U_{aux}$ disconnected
X4.1-5	Closed; no IRF, and $U_{aux}$ connected

**Table 5.2.1.-4 Output contacts**

Terminal	Function
X3.1-16	SO5, common <sup>a)</sup>
X3.1-17	SO5, NC <sup>a)</sup>
X3.1-18	SO5, NO <sup>a)</sup>
X3.1-19	SO4, common <sup>a)</sup>
X3.1-20	SO4, NC <sup>a)</sup>
X3.1-21	SO4, NO <sup>a)</sup>
X3.1-22	SO3, common <sup>a)</sup>
X3.1-23	SO3, NC <sup>a)</sup>
X3.1-24	SO3, NO <sup>a)</sup>
X4.1-6	SO2, common
X4.1-7	SO2, NC
X4.1-8	SO2, NO
X4.1-9	SO1, common
X4.1-10	SO1, NC
X4.1-11	SO1, NO
X4.1-12	PO3 (trip lockout relay), NO
X4.1-13	
X4.1-14	PO2, NO

Terminal	Function
X4.1-15	
X4.1-16 X4.1-17	PO1, NO
X4.1-18 X4.1-19	PO1 (TCS), NO
X4.1-20	-

<sup>a)</sup> Optional.

**Table 5.2.1-5 Digital inputs**

Terminal	Function
X4.1-23 X4.1-24	DI1
X4.1-21 X4.1-22	DI2
X3.1-1 X3.1-2	DI3 <sup>a)</sup>
X3.1-3 X3.1-4	DI4 <sup>a)</sup>
X3.1-5 X3.1-6	DI5 <sup>a)</sup>

<sup>a)</sup> Optional.

## 5.2.2.

### Serial communication connections

The optical front connection of the relay is used to connect the relay to the SPA bus via the front communication cable, refer to Section 6. Ordering information. If a PC compatible to the IrDA® Standard specifications is used, wireless communication is possible as well. The maximum wireless operating distance depends on the transceiver of the PC.

Rear communication of the relay is optional and the physical connection varies with the communication option.

### Plastic fibre-optic connection

If the relay is provided with the optional fibre-optic communication module for plastic fibre, the fibre-optic cables are connected to terminals as follows:

**Table 5.2.2-1 Plastic fibre-optic rear connection**

Terminal	Function
X5.3-TX	Transmitter
X5.3-RX	Receiver

### RS-485 connection

If the relay is provided with the optional RS-485 communication module, the cable is connected to terminals X5.5/1-2 and X5.5/4-6. The connection socket is a 6-pin header-type socket and the terminals are of screw compression type.

The RS-485 communication module follows the TIA/EIA-485 standard and is intended to be used in a daisy-chain bus wiring scheme with 2-wire, half-duplex, multi-point communication.



The maximum number of devices (nodes) connected to the bus where the relay is being used is 32, and the maximum length of the bus is 1200 meters.

When connecting the relay to the bus, a quality twisted pair shielded cable is to be used. The conductors of the pair are connected to A and B. If signal ground is being used for balancing potential differences between devices/nodes, a quality dual twisted pair shielded cable is to be used. In this case, one pair is connected to A and B, and one of the conductors of the other pair to signal ground. When connecting one device to another, A is connected to A and B to B.

The cable shield is to be connected directly to ground (shield GND) in one point/device of the bus. Other devices connected to the bus should have the cable shield connected to ground via a capacitor (shield GND via capacitor).



Signal ground can only be used for balancing potential differences between devices/nodes if all devices connected to the bus have isolated RS-485 interfaces.

The RS-485 communication module is provided with jumpers for setting bus termination and fail-safe biasing. The bus is to be terminated at both ends, which can be done by using the internal termination resistor on the communication module. The termination resistor is selected by setting jumper X5 to the ON position. If the internal termination resistor of 120  $\Omega$  is used, the impedance of the cable should be the same.

The bus is to be biased at one end to ensure fail-safe operation, which can be done using the pull-up and pull-down resistors on the communication module. The pull-up and pull-down resistors are selected by setting jumpers X3 and X4 to the ON position.

The jumpers have been set to no termination (X5 in the OFF position) and no biasing (X3 and X4 in the OFF position) as default.

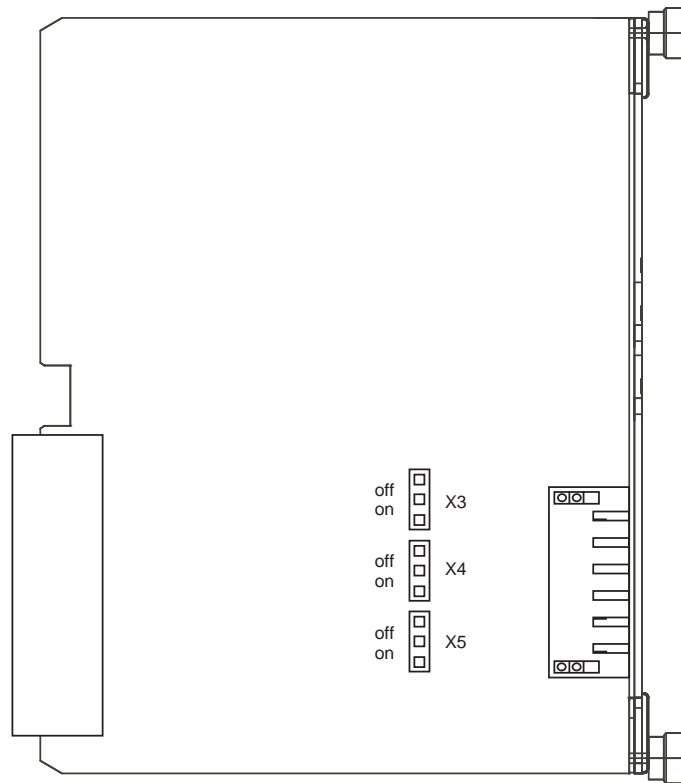

A040334

Fig. 5.2.2.-1 Jumper location on the RS-485 communication module

**Table 5.2.2.-2 RS-485 rear connector**

Terminal	Function
X5.5-6	Data A (+)
X5.5-5	Data B (-)
X5.5-4	Signal GND (for potential balancing)
X5.5-3	-
X5.5-2	Shield GND (via capacitor)
X5.5-1	Shield GND

### Combined fibre-optic connection (plastic and glass)

If the relay is provided with the optional fibre-optic communication module for plastic and glass fibre, the plastic fibre-optic cables are connected to terminals X5.3-RX (Receiver) and X5.3-TX (Transmitter) and the glass fibre-optic cables to terminals X5.4-RX (Receiver) and X5.4-TX (Transmitter).

The fibre-optic interface is selected with jumpers X6 and X2 located on the PCB of the communication module (see Fig. 5.2.2.-2).

**Table 5.2.2.-3 Transmitter selection**

Transmitter	Position of jumper X6
Plastic	X5.3-TX
Glass	X5.4-TX

**Table 5.2.2.-4 Receiver selection**

Transmitter	Position of jumper X2
Plastic	X5.3-RX
Glass	X5.4-RX

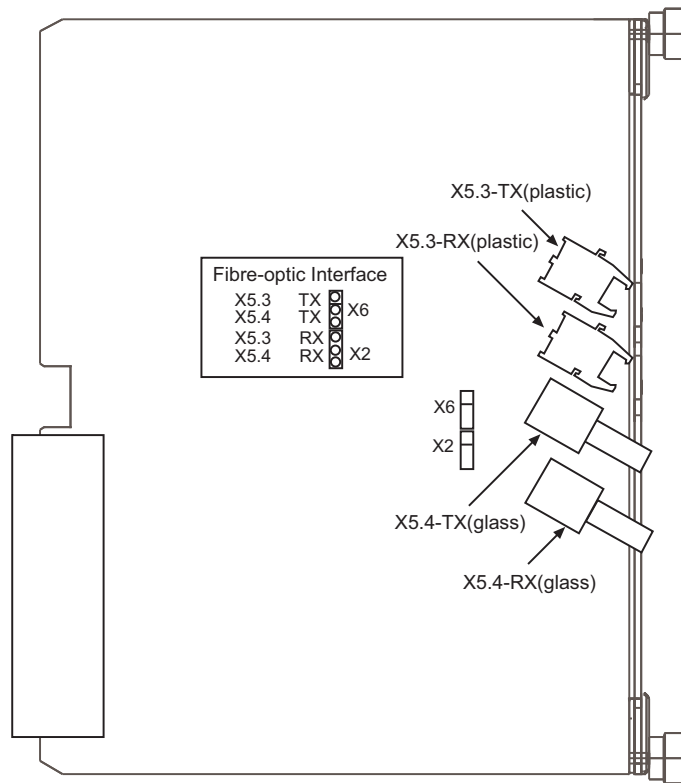

A040335

*Fig. 5.2.2.-2 Jumper location on the communication module for plastic and glass fibre*

**Table 5.2.2.-5 Fibre-optic rear connectors (plastic and glass)**

Terminal	Function
X5.3-TX	Transmitter for plastic fibre
X5.3-RX	Receiver for plastic fibre
X5.4-TX	Transmitter for glass fibre
X5.4-RX	Receiver for plastic fibre

**RS-485 connection for the DNP 3.0 communication module**

If the relay is provided with the optional DNP 3.0 communication module, the cable is connected to terminals X5.8/1-2 and X5.8/4-8. The connection socket is a 8-pin header-type socket and the terminals are of screw compression type.

The DNP communication module follows the DNP standard and is intended to be used in a daisy-chain bus wiring scheme with 2- or 4-wire, half-duplex, multi-point communication.



The maximum number of devices (nodes) connected to the bus where the relay is being used is 32, and the maximum length of the bus is 1200 meters in optimum conditions and with slow communication speed.

When connecting the relay to the bus, a quality twisted pair shielded cable is to be used. The conductors of the pair are connected to A and B. If signal ground is being used for balancing potential differences between devices/nodes, a quality dual twisted pair shielded cable is to be used. In this case, one pair is connected to A and B, and one of the conductors of the other pair to signal ground. When connecting one device to another, A is connected to A and B to B.

When using a 4-wire bus, one pair is connected to +RX and -RX and the other to +TX and -TX. If signal ground is being used, a quality cable with three or several pairs is to be used and one of the conductors of a pair connected to signal ground.

The cable shield is to be connected directly to ground (shield GND) in one point/device of the bus. Other devices connected to the bus should have the cable shield connected to ground via a capacitor (shield GND via capacitor).



Signal ground can only be used for balancing potential differences between devices/nodes if all devices connected to the bus have isolated DNP interfaces.

The DNP communication module is provided with jumpers for setting bus termination and fail-safe biasing. The bus is to be terminated at both ends, which can be done by using the internal termination resistor on the DNP communication module. The termination resistor is selected by setting jumper X6 or/and X12 to the ON position. If the internal termination resistor of 120Ω is used, the impedance of the cable should be the same.

The bus is to be biased at one end to ensure fail-safe operation, which can be done using the pull-up and pull-down resistors on the communication module. The pull-up and pull-down resistors are selected by setting jumpers X8, X7, X13 and X11 to the ON position.

The 2-wire bus is selected by default (jumper X14) without termination or biasing. The jumpers X6, X7, X8 and X12 are in OFF position. The jumpers X11 and X13 are in ON position.

**Table 5.2.2.-6 RS-485 rear connector (DNP 3.0)**

Terminal	Function
X5.8-8	Data A (+ RX)
X5.8-7	Data B (- RX)
X5.8-6	Data A (+ TX)
X5.8-5	Data B (- TX)
X5.8-4	Signal GND (for potential balancing)
X5.8-3	-
X5.8-2	Shield GND (via capacitor)
X5.8-1	Shield GND

**Table 5.2.2.-7 Jumper numbering**

Terminal	Function	Signal
X8	Pull-up	Data A (+ TX)
X6	Termination	TX
X7	Pull-down	Data B (- TX)
X13	Pull-up	Data A (+ RX)
X12	Termination	RX
X11	Pull-down	Data B (- RX)
X14	4-wire/2-wire	-

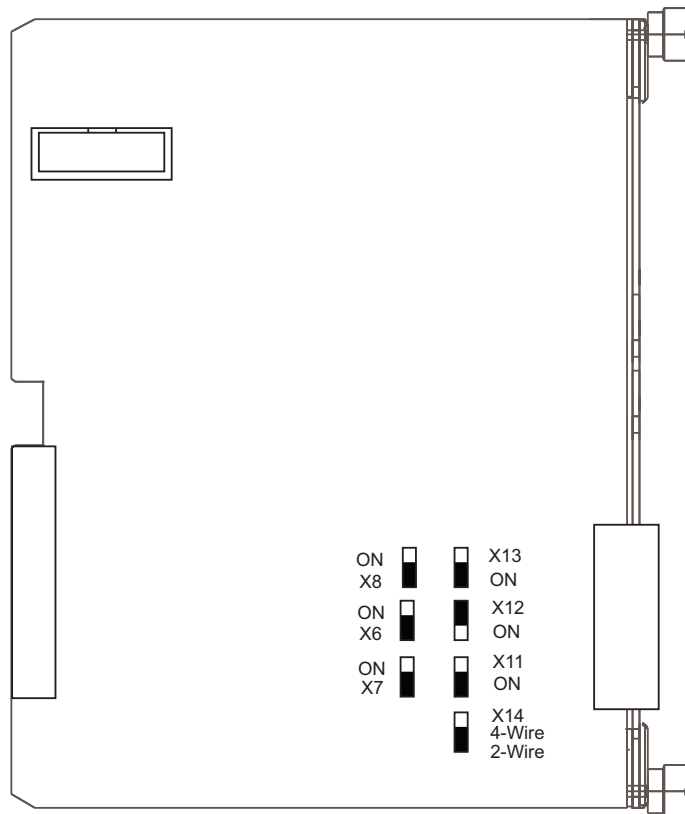

A040357\_2

*Fig. 5.2.2.-3 Jumper location on the DNP 3.0 communication module*

## 5.2.3.

## Technical data

**Table 5.2.3.-1 Dimensions (for dimension drawings, refer to the Installation Manual)**

Width, frame 177 mm, case 164 mm
Height, frame 177 mm (4U), case 160 mm
Depth, case 149.3 mm
Weight of the relay ~3.5 kg
Weight of the spare unit ~1.8 kg

**Table 5.2.3.-2 Power supply**

U <sub>aux</sub> rated: -REU610CVVHxxx -REU610CVVLxxx	U <sub>r</sub> = 100/110/120/220/240 V AC U <sub>r</sub> = 110/125/220/250 V DC U <sub>r</sub> = 24/48/60 V DC
U <sub>aux</sub> variation (temporary): -REU610CVVHxxx -REU610CVVLxxx	85...110% of U <sub>r</sub> (AC) 80...120% of U <sub>r</sub> (DC) 80...120% of U <sub>r</sub> (DC)
Burden of auxiliary voltage supply under quiescent (P <sub>q</sub> )/operating condition	<9 W/13 W
Ripple in the DC auxiliary voltage	Max 12% of the DC value (at frequency of 100 Hz)
Interruption time in the auxiliary DC voltage without resetting the relay	<50 ms at U <sub>aux</sub> rated
Time to trip from switching on the auxiliary voltage <sup>a)</sup>	<350 ms
Internal over temperature limit	+100°C
Fuse type	T2A/250 V

<sup>a)</sup> Time to trip of element 59P-2.

**Table 5.2.3.-3 Energizing inputs**

Rated frequency	50/60 Hz ±5 Hz
Rated voltage, U <sub>n</sub> (VT)	100/110/115/120 V
Thermal withstand capability: • continuously • for 10 s	2 × U <sub>n</sub> (VT) (240 V) 3 × U <sub>n</sub> (VT) (360 V)
Burden at rated voltage	<0.5 VA

**Table 5.2.3.-4 Measuring range**

Measured phase-to-phase voltages U <sub>ab</sub> , U <sub>bc</sub> and U <sub>ca</sub> as multiples of the rated voltages of the energizing inputs	0...2 × U <sub>n</sub> (VT)
Measured residual voltage (U <sub>n</sub> ) as a multiple of the rated voltage of the energizing input	0...2 × U <sub>n</sub> (VT)

**Table 5.2.3.-5 Digital inputs**

Rated voltage:	DI1...DI2	DI3...DI5 (optional)
REU610CVVHxxx	110/125/220/250 V DC	
Activating threshold	Max. 88 V DC (110 V DC - 20%)	
REU610CVVLxxx	24/48/60/110/125/ 220/250 V DC	
Activating threshold	Max. 19,2 V DC (24 V DC - 20%)	
REU610CVVxxLx		24/48/60/110/125/ 220/250 V DC
Activating threshold		Max. 19,2 V DC (24 V DC -20%)
REU610CVVxxHx		110/125/220/250 V DC
Activating threshold		Max. 88 V DC (110 V DC -20%)
Operating range	±20% of the rated voltage	
Current drain	2...18 mA	
Power consumption/input	≤0.9 W	

**Table 5.2.3.-6 Non-trip output SO1 and optional SO4 and SO5**

Rated voltage	250 V AC/DC
Continuous carry	5 A
Make and carry for 3.0 s	15 A
Make and carry for 0.5 s	30 A
Breaking capacity when the control-circuit time constant L/R <40 ms, at 48/110/220 V DC	1 A/0.25 A/0.15 A (5 A/3 A/1 A for series connection of SO4 and SO5)
Minimum contact load	100 mA at 24 V AC/DC

**Table 5.2.3.-7 Non-trip output SO2, optional SO3, and IRF output**

Rated voltage	250 V AC/DC
Continuous carry	5 A
Make and carry for 3.0 s	10 A
Make and carry for 0.5 s	15 A
Breaking capacity when the control-circuit time constant L/R <40 ms, at 48/110/220 V DC	1 A/0.25 A/0.15 A
Minimum contact load	100 mA at 24 V AC/DC

**Table 5.2.3.-8 Trip outputs (PO1, PO2, PO3)**

Rated voltage	250 V AC/DC
Continuous carry	5 A
Make and carry for 3.0 s	15 A
Make and carry for 0.5 s	30 A
Breaking capacity when the control-circuit time constant L/R <40 ms, at 48/110/220 V DC (PO1 with both contacts connected in series)	5 A/3 A/1 A
Minimum contact load	100 mA at 24 V AC/DC
Trip-circuit supervision (TCS):	
• Control voltage range	20...265 V AC/DC

• Current drain through the supervision circuit	~1.5 mA
• Minimum voltage over a contact	20 V AC/DC (15...20 V)

**Table 5.2.3.-9 Enclosure class of the flush-mounted relay**

Front side	IP 54 Category 2
Rear side, top of the relay	IP 40
Rear side, connection terminals	IP 20

**Table 5.2.3.-10 Environmental tests and conditions**

Recommended service temperature range (continuous)	-10...+55°C
Humidity	< 95% RH
Limit temperature range (short-term)	-40...+70°C
Transport and storage temperature range	-40...+85°C according to IEC 60068-2-48
Dry heat test (humidity <50%)	According to IEC 60068-2-2
Dry cold test	According to IEC 60068-2-1
Damp heat test, cyclic (humidity >93%)	According to IEC 60068-2-30
Atmospheric pressure	86...106 kPa

**Table 5.2.3.-11 Electromagnetic compatibility tests**

EMC immunity test level meets the requirements listed below:	
1 MHz burst disturbance test, class III	According to IEC 60255-22-1, IEC 61000-4-18
• Common mode	2.5 kV
• Differential mode	1.0 kV
Electrostatic discharge test, class IV	According to IEC 61000-4-2, IEC 60255-22-2 and ANSI C37.90.3-2001
• For contact discharge	8 kV
• For air discharge	15 kV
Radio frequency interference tests:	
• Conducted, common mode	According to IEC 61000-4-6 and IEC 60255-22-6 (2000) 10 V (rms), f = 150 kHz...80 MHz
• Radiated, amplitude-modulated	According to IEC 61000-4-3 and IEC 60255-22-3 (2000) 10 V/m (rms), f = 80...1000 MHz
• Radiated, pulse-modulated	According to the ENV 50204 and IEC 60255-22-3 (2000) 10 V/m, f = 900 MHz
Fast transient disturbance tests	According to IEC 60255-22-4 and IEC 61000-4-4
• Trip outputs, energizing inputs, power supply	4 kV
• I/O ports	2 kV
Surge immunity test	According to IEC 61000-4-5 and IEC 60255-22-5
• Trip outputs, energizing inputs, power supply	4 kV, line-to-ground 2 kV, line-to-line
• I/O ports	2 kV, line-to-ground 1 kV, line-to-line

Technical Reference Manual - ANSI Version

Power frequency (50 Hz) magnetic field IEC 61000-4-8	300 A/m continuous
Power frequency immunity test:  REU610CVVHxxx and REU610CVVxxHx <ul style="list-style-type: none"> <li>• Common mode</li> <li>• Differential mode</li> </ul> REU610CVVLxxx and REU610CVVxxLx <ul style="list-style-type: none"> <li>• Common mode</li> <li>• Differential mode</li> </ul>	According to IEC 60255-22-7 and IEC 61000-4-16  Class A 300 V rms 150 V rms  Class B 300 V rms 100 V rms
Voltage dips and short interruptions	According to IEC 61000-4-11 30%/10 ms 60%/100 ms 60%/1000 ms >95%/5000 ms
Electromagnetic emission tests <ul style="list-style-type: none"> <li>• Conducted, RF-emission (Mains terminal)</li> <li>• Radiated RF-emission</li> </ul>	According to the EN 55011 EN 55011, class A, IEC 60255-25 EN 55011, class A, IEC 60255-25
CE approval	Complies with the EMC directive EMC 2004/108/EC and the LV directive LV 2006/95/EC

**Table 5.2.3.-12 Standard tests**

<b>Insulation tests:</b>	
Dielectric tests <ul style="list-style-type: none"> <li>• Test voltage</li> </ul>	According to IEC 60255-5 2 kV, 50 Hz, 1 min
Impulse voltage test <ul style="list-style-type: none"> <li>• Test voltage</li> </ul>	According to IEC 60255-5 5 kV, unipolar impulses, waveform 1.2/50 μs, source energy 0.5 J
Insulation resistance measurements <ul style="list-style-type: none"> <li>• Isolation resistance</li> </ul>	According to IEC 60255-5 >100 MΩ, 500 V DC
<b>Mechanical tests:</b>	
Vibration tests (sinusoidal)	According to IEC 60255-21-1, class I
Shock and bump test	According to IEC 60255-21-2, class I

**Table 5.2.3.-13 Data communication**

Rear interface: <ul style="list-style-type: none"> <li>• Fibre-optic or RS-485 connection</li> <li>• SPA bus, IEC 60870-5-103, DNP 3.0 or Modbus protocol</li> <li>• 9.6 or 4.8 kbps (additionally 2.4, 1.2 or 0.3 kbps for Modbus)</li> </ul>
Front interface: <ul style="list-style-type: none"> <li>• Optical connection (infrared): wirelessly or via the front communication cable (1MRS050698)</li> <li>• SPA bus protocol</li> <li>• 9.6 or 4.8 kbps (9.6 kbps with front communication cable)</li> </ul>

**Optional communication modules and protocols**

- SPA-bus, IEC 60870-5-103, Modbus® (RTU and ASCII):
  - Plastic fibre
  - Plastic and glass fibre
  - RS485
- DNP 3.0:
  - RS485 including DNP 3.0 protocol

**Auxiliary voltage**

The relay requires a secured auxiliary voltage supply to operate. The internal power supply of the relay forms the voltages required by the relay electronics. The power supply is a galvanically isolated (flyback-type) DC/DC converter. When the auxiliary voltage is connected, the green target LED (ready) on the front panel is lit. For detailed information on power supply, refer to Table 5.2.3.-2.

The primary side of the power supply is protected with a fuse located on the printed circuit board of the relay.



## 6. Ordering information

When ordering voltage relays and/or accessories, specify the following:

- Order number
- HMI language set number
- Quantity

The order number identifies the voltage relay type and hardware as described in the figures below and is labelled on the marking strip under the lower handle of the relay.

Use the ordering key information in Fig. 6.-1 to generate the order number when ordering complete voltage relays.

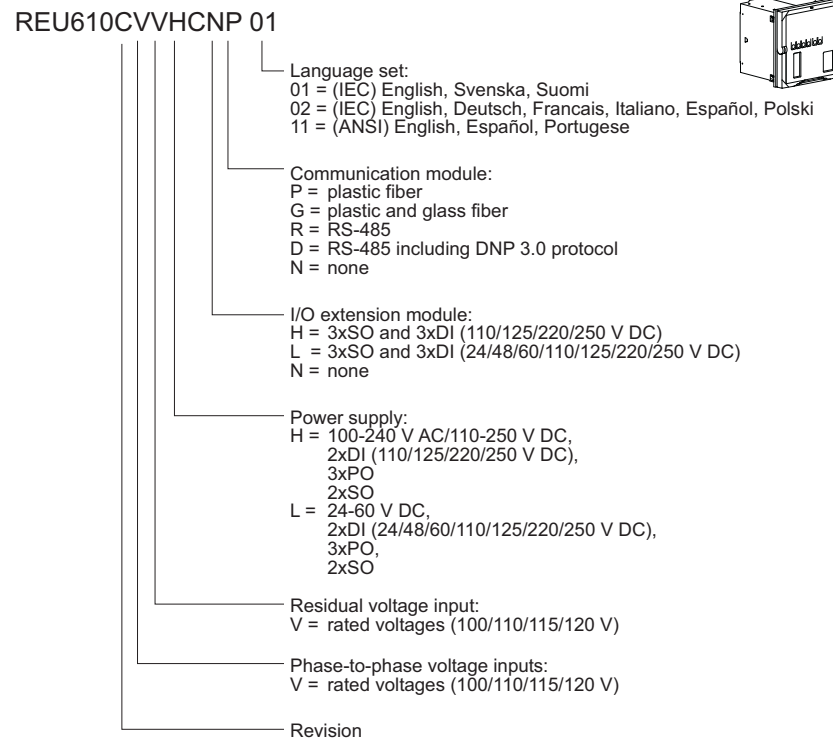

A052080\_2

Fig. 6.-1 Ordering key for complete relays

Use the ordering key information in Fig. 6.-2 to generate the order number when ordering spare units.

Technical Reference Manual - ANSI Version

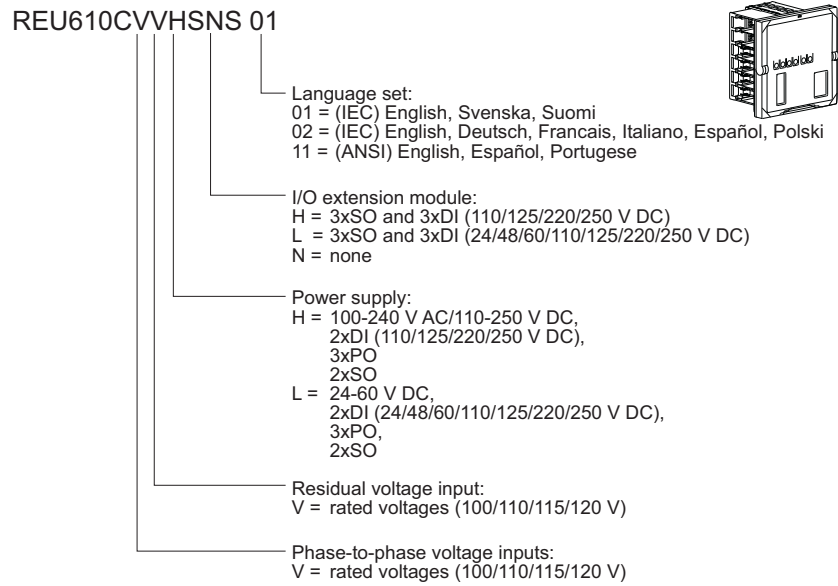

A052093\_2

Fig. 6.-2 Ordering key for spare units

The following accessories are available:

Item	Order number
Semi-flush mounting kit	1MRS050696
Inclined (/ 25°) semi-flush mounting kit	1MRS050831
Wall mounting kit	1MRS050697
19" Rack mounting kit, two relays side-by-side	1MRS050695
19" Rack mounting kit, single relay	1MRS050694
19" Rack mounting kit, single relay and RTXP18 (REU610)	1MRS090937
19" equipment frame mounting kit (Combiflex), single relay and RTXP18 (REU610)	1MRS090936
19" equipment frame mounting kit (Combiflex), single relay	1MRS050779
Front communication cable	1MRS050698
Communication modules:	
• Plastic fibre	1MRS050889
• RS-485	1MRS050892
• Plastic and glass fibre	1MRS050891
• RS-485 including DNP 3.0 protocol	1MRS050887

## 7. Check lists

**Table 7.-1 Setting group 1**

Variable	Group/ Channel 1 (R, P)	Setting range	Default setting	Customer's setting
Pickup value of element 59P-1	1S1	0.60...1.40 × U <sub>n</sub> (VT)	1.2 × U <sub>n</sub> (VT)	
Operate time of element 59P-1	1S2	0.06...600 s	0.06 s	
IDMT operation mode setting for element 59P-1	1S3	0...2	0	
IDMT time dial 59P-1 TD	1S4	0.05...2.00	0.05	
Resetting time of element 59P-1	1S5	0.07...60.0 s	0.07 s	
Drop-off/pick-up ratio 59P-1 D/P	1S6	0.95...0.99	0.97	
U <sub>1</sub> /U <sub>2</sub> mode setting of elements 59P-2 and 27P-2	1S7	0...2	0	
Pickup value of element 59P-2	1S8	0.80...1.60 × U <sub>n</sub> (VT)	1.20 × U <sub>n</sub> (VT)	
Pickup value of element 47	1S9	0.05...1.00 × U <sub>n</sub> (VT)	0.05 × U <sub>n</sub> (VT)	
Operate time of element 59P-2	1S10	0.05...600 s	0.05 s	
IDMT operation mode setting for element 59P-2	1S11	0...2	0	
IDMT time dial 59P-2 TD	1S12	0.05...2.00	0.05	
Pickup value of element 27P-1	1S13	0.20...1.20 × U <sub>n</sub> (VT)	0.20 × U <sub>n</sub> (VT)	
Operate time of element 27P-1	1S14	0.10...600 s	0.10 s	
IDMT operation mode setting for element 27P-1	1S15	0...1	0	
IDMT time dial 27P-1 TD	1S16	0.10...2.00	0.10	
Resetting time of element 27P-1	1S17	0.07...60.0 s	0.07 s	
Drop-off/pick-up ratio 27P-1 D/P	1S18	1.01...1.05	1.03	
Pickup value of element 27P-2	1S19	0.20...1.20 × U <sub>n</sub> (VT)	0.20 × U <sub>n</sub> (VT)	
Pickup value of element 27D	1S20	0.20...1.20 × U <sub>n</sub> (VT)	0.20 × U <sub>n</sub> (VT)	
Operate time of element 27P-2	1S21	0.10...600 s	0.10 s	
IDMT operation mode setting for element 27P-2	1S22	0...1	0	
IDMT time dial 27P-2 TD	1S23	0.10...2.00	0.10	
Pickup value of element 59N-1	1S24	2.0...80.0% U <sub>n</sub> (VT)	2.0% U <sub>n</sub> (VT)	
Operate time of element 59N-1	1S25	0.10...600 s	0.10 s	
Resetting time of element 59N- 1	1S26	0.07...60.0 s	0.07s	
Pickup value of element 59N-2	1S27	2.0...80.0% U <sub>n</sub> (VT)	2.0% U <sub>n</sub> (VT)	
Operate time of element 59N-2	1S28	0.10...600 s	0.10 s	
Predefined time of CBFAIL	1S29	0.10...60.0 s	0.10 s	
Checksum, SGF1	1S61	0...255	0	

## Technical Reference Manual - ANSI Version

Variable	Group/ Channel 1 (R, P)	Setting range	Default setting	Customer's setting
Checksum, SGF2	1S62	0...4095	2730	
Checksum, SGF3	1S63	0...15	0	
Checksum, SGF4	1S64	0...1023	128	
Checksum, SGF5	1S65	0...255	0	
Checksum, SGB1	1S71	0...32767	0	
Checksum, SGB2	1S72	0...32767	0	
Checksum, SGB3	1S73	0...32767	0	
Checksum, SGB4	1S74	0...32767	0	
Checksum, SGB5	1S75	0...32767	0	
Checksum, SGR1	1S81	0...8191	2730	
Checksum, SGR2	1S82	0...8191	2730	
Checksum, SGR3	1S83	0...8191	2730	
Checksum, SGR4	1S84	0...8191	1365	
Checksum, SGR5	1S85	0...8191	1365	
Checksum, SGR6	1S86	0...8191	0	
Checksum, SGR7	1S87	0...8191	0	
Checksum, SGR8	1S88	0...8191	0	
Checksum, SGL1	1S91	0...16383	0	
Checksum, SGL2	1S92	0...16383	0	
Checksum, SGL3	1S93	0...16383	0	
Checksum, SGL4	1S94	0...16383	0	
Checksum, SGL5	1S95	0...16383	0	
Checksum, SGL6	1S96	0...16383	0	
Checksum, SGL7	1S97	0...16383	0	
Checksum, SGL8	1S98	0...16383	0	

Table 7.-2 Setting group 2

Variable	Group/ Channel 2 (R, P)	Setting range	Default setting	Customer's setting
Pickup value of element 59P-1	2S1	$0.60...1.40 \times U_n$ (VT)	$1.2 \times U_n$ (VT)	
Operate time of element 59P-1	2S2	0.06...600 s	0.06 s	
IDMT operation mode setting for element 59P-1	2S3	0...2	0	
IDMT time dial 59P-1 TD	2S4	0.05...2.00	0.05	
Resetting time of element 59P-1	2S5	0.07...60.0 s	0.07 s	
Drop-off/pick-up ratio 59P-1 D/P	2S6	0.95...0.99	0.97	
$U_1/U_2$ mode setting of elements 59P-2 and 27P-2	2S7	0...2	0	
Pickup value of element 59P-2	2S8	$0.80...1.60 \times U_n$ (VT)	$1.20 \times U_n$ (VT)	
Pickup value of element 47	2S9	$0.05...1.00 \times U_n$ (VT)	$0.05 \times U_n$ (VT)	

Variable	Group/ Channel 2 (R, P)	Setting range	Default setting	Customer's setting
Operate time of element 59P-2	2S10	0.05...600 s	0.05 s	
IDMT operation mode setting for element 59P-2	2S11	0...2	0	
IDMT time dial 59P-2 TD	2S12	0.05...2.00	0.05	
Pickup value of element 27P-1	2S13	0.20...1.20 × U <sub>n</sub> (VT)	0.20 × U <sub>n</sub> (VT)	
Operate time of element 27P-1	2S14	0.10...600 s	0.10 s	
IDMT operation mode setting for element 27P-1	2S15	0...1	0	
IDMT time dial 27P-1	2S16	0.10...2.00	0.10	
Resetting time of element 27P-1	2S17	0.07...60.0 s	0.07 s	
Drop-off/pick-up ratio D/P<	2S18	1.01...1.05	1.03	
Pickup value of element 27P-2	2S19	0.20...1.20 × U <sub>n</sub> (VT)	0.20 × U <sub>n</sub> (VT)	
Pickup value of element 27D	2S20	0.20...1.20 × U <sub>n</sub> (VT)	0.20 × U <sub>n</sub> (VT)	
Operate time of element 27P-2	2S21	0.10...600 s	0.10 s	
IDMT operation mode setting for element 27P-2	2S22	0...1	0	
IDMT time dial 27P-2 TD	2S23	0.10...2.00	0.10	
Pickup value of element 59N-1	2S24	2.0...80.0% U <sub>n</sub> (VT)	2.0% U <sub>n</sub> (VT)	
Operate time of element 59N-1	2S25	0.10...600 s	0.10 s	
Resetting time of element 59N-1	2S26	0.07...60.0 s	0.07 s	
Pickup value of element 59N-2	2S27	2.0...80.0% U <sub>n</sub> (VT)	2.0% U <sub>n</sub> (VT)	
Operate time of element 59N-2	2S28	0.10...600 s	0.10 s	
Predefined time of CBFAIL	2S29	0.10...60.0 s	0.10 s	
Checksum, SGF1	2S61	0...255	0	
Checksum, SGF2	2S62	0...4095	2730	
Checksum, SGF3	2S63	0...15	0	
Checksum, SGF4	2S64	0...1023	128	
Checksum, SGF5	2S65	0...255	0	
Checksum, SGB1	2S71	0...32767	0	
Checksum, SGB2	2S72	0...32767	0	
Checksum, SGB3	2S73	0...32767	0	
Checksum, SGB4	2S74	0...32767	0	
Checksum, SGB5	2S75	0...32767	0	
Checksum, SGR1	2S81	0...8191	2730	
Checksum, SGR2	2S82	0...8191	2730	
Checksum, SGR3	2S83	0...8191	2730	
Checksum, SGR4	2S84	0...8191	1365	
Checksum, SGR5	2S85	0...8191	1365	

Variable	Group/ Channel 2 (R, P)	Setting range	Default setting	Customer's setting
Checksum, SGR6	2S86	0...8191	0	
Checksum, SGR7	2S87	0...8191	0	
Checksum, SGR8	2S88	0...8191	0	
Checksum, SGL1	2S91	0...16383	0	
Checksum, SGL2	2S92	0...16383	0	
Checksum, SGL3	2S93	0...16383	0	
Checksum, SGL4	2S94	0...16383	0	
Checksum, SGL5	2S95	0...16383	0	
Checksum, SGL6	2S96	0...16383	0	
Checksum, SGL7	2S97	0...16383	0	
Checksum, SGL8	2S98	0...16383	0	

**Table 7.-3 Control parameters**

Variable	Parameter (channel 0)	Setting range	Default setting	Customer's setting
Network frequency	V104	50 or 60 Hz	60 Hz	
Trip-circuit supervision	V113	0/1	0	
Nominal voltage	V134	0 = 100 V 1 = 110 V 2 = 115 V 3 = 120 V	0	
Data communication address of the relay	V200	1...254 <sup>a)</sup>	1	
Data transfer rate for SPA	V201	4.8/9.6	9.6	
Rear communication protocol	V203	0 = SPA 1 = IEC 103 2 = Modbus RTU 3 = Modbus ASCII	0	
Connection type selection (loop/star)	V204	0/1	0	
Line-idle state selection (light-off/light-on)	V205	0/1	0	
Rear communication module enabled/disabled	V206	1/0	0	

<sup>a)</sup> For all the protocols except for DNP 3.0.

**Table 7.-4 Disturbance recorder parameters**

Variable	Parameter (channel 0)	Setting range	Default setting	Customer's setting
Sampling rate	M15	800/960 Hz 400/480 Hz 50/60 Hz	800/960 Hz	
Station identification/unit number	M18	0...9999	0	

Variable	Parameter (channel 0)	Setting range	Default setting	Customer's setting
Station name	M20	Max 16 characters	-ABB-	
Analog channel conversion factor and units	M80, M81, M82	Factor 0.00...600, unit (V, kV), e.g. 20.0 kV	0.01, VT	
Analog channel conversion factor and units	M83	Factor 0.00...600, unit (V, kV), e.g. 20.0 kV	0.01, VT	
Internal trigger signals' checksum	V236	0...4095	2730	
Internal trigger signal's edge	V237	0...4095	0	
Checksum of internal signal storing mask	V238	0...4095	2798	
Post-trigger time in percent	V240	0...100%	50	
External trigger signal's checksum	V241	0...31	0	
External trigger signal's edge	V242	0...31	0	
Checksum of external signal storing mask	V243	0...31	0	



## 8. Abbreviations

Abbreviation	Description
ASCII	American Standard Code for Information Interchange
AWG	American wire gauge
CBFAIL	Circuit-breaker failure protection
CBFP	Circuit-breaker failure protection
CD	Change detect; compact disk
CPU	Central processing unit
CRC	Cyclical redundancy check
DI	Digital input
EEPROM	Electrically Erasable Programmable Read-Only Memory
EMC	Electromagnetic compatibility
EPA	Enhanced Performance Architecture
ER	Event records
FR	Fault record
GI	General interrogation
HMI	Human-machine interface
HR	Holding register
IDMT	Inverse definite minimum time characteristic
IEC	International Electrotechnical Commission
IEC_103	Standard IEC 60870-5-103
IED	Intelligent electronic device
IEEE	Institute of Electrical and Electronics Engineers, Inc.
IR	Input register
IRF	Internal relay fault
ISO	International Organization for Standardization
LCD	Liquid crystal display
LED	Light-emitting diode
LRC	Longitudinal redundancy check
MP	Minute-pulse
MSB	Most significant bit
NACK	Negative acknowledgments
NC	Normally closed
NO	Normally open
NPS	Negative-phase-sequence
OSI	Open System Interconnection
PC	Personal computer
PCB	Printed circuit board
PLC	Programmable logical controller
PO	Power output, process object
RMS	Root mean square
RTU	Remote terminal unit

## Technical Reference Manual - ANSI Version

---

SGB	Switchgroup for digital inputs
SGL	Switchgroup for LEDs
SGR	Switchgroup for output contacts
SO	Signal output
SP	Second-pulse
SPA	Data communication protocol developed by ABB
TCS	Trip-circuit supervision
UDR	User-defined register
UR	Unsolicited reporting
VT	Voltage transformer









**ABB Oy**  
Distribution Automation  
P.O. Box 699  
FI-65101 Vaasa  
FINLAND  
+358 10 2211  
+358 10 224 1094  
[www.abb.com/substationautomation](http://www.abb.com/substationautomation)