

Feeder Terminal REF 54_

Technical Reference Manual, General



Contents

1. About this manual	7
1.1. Copyrights	7
1.2. Trademarks	7
1.3. Guarantee	7
1.4. General	7
1.5. Use of symbols	8
1.6. Terminology	8
1.7. Abbreviations	9
1.8. Related documents	10
1.9. Document revisions	10
2. Safety information	11
3. Introduction	13
3.1. General	13
3.2. Hardware versions	13
4. Instructions	17
4.1. Application	17
4.2. Requirements	19
4.3. Terminal configuration	19
5. Technical Description	21
5.1. Functional description	21
5.1.1. Functions of the feeder terminal	21
5.1.1.1. Protection functions	21
5.1.1.2. Measurement functions	23
5.1.1.3. Power quality functions	23
5.1.1.4. Control functions	24
5.1.1.5. Condition monitoring functions	25
5.1.1.6. Communication functions	25
5.1.1.7. General functions	26
5.1.1.8. Standard functions	26
5.1.2. Configuration	28
5.1.2.1. Feeder terminal configuration	28
5.1.2.2. MIMIC configuration	29
5.1.2.3. LON network configuration	31
5.1.2.4. DNP 3.0 and Modbus configuration	31
5.1.2.5. Rated frequency	31
5.1.3. Parameters and events	32

5.1.4. Parameterization	32
5.1.4.1. Local parameterization	32
5.1.4.2. External parameterization	32
5.1.4.3. Storing of parameters and recorded data	33
5.1.5. Auxiliary voltage	34
5.1.5.1. Power supply versions	34
5.1.5.2. Low auxiliary voltage indication	35
5.1.5.3. Overtemperature indication	35
5.1.6. Analog channels	36
5.1.6.1. Scaling the rated values of the protected unit for analog channels	38
5.1.6.2. Technical data of the measuring devices	39
5.1.6.3. Calculated analog channels	42
5.1.7. Digital inputs	43
5.1.7.1. Filter time of a digital input	44
5.1.7.2. Inversion of a digital input	45
5.1.7.3. Pulse counters	45
5.1.7.4. Oscillation suppression	46
5.1.7.5. Attributes of a digital input for feeder terminal configuration	47
5.1.8. Digital outputs	48
5.1.8.1. High-speed double-pole power outputs (HSPO)	49
5.1.8.2. Single-pole power outputs (PO) and a high-speed single-pole power output (HSPO) ...	50
5.1.8.3. Double-pole power outputs (PO)	50
5.1.8.4. Signal outputs (SO)	51
5.1.9. RTD/analog inputs	51
5.1.9.1. Selection of input signal type	52
5.1.9.2. Selection of input signal range	52
5.1.9.3. Transducer supervision	54
5.1.9.4. Signal filtering	54
5.1.9.5. Input scaling/linearization	55
5.1.9.6. Transducer connections	55
5.1.9.7. Attributes of an RTD/analog input for feeder terminal configuration	58
5.1.9.8. RTD/analog input configuration example	58
5.1.9.9. Self-supervision	59
5.1.9.10. Calibration	59
5.1.9.11. RTD temperature vs. resistance	60

Technical Reference Manual, General

5.1.10. Analog outputs	61
5.1.10.1. Selection of analog output range	61
5.1.10.2. Attributes of an analog output for feeder terminal configuration	61
5.1.10.3. Analog output configuration example	62
5.1.11. Trip circuit supervision	63
5.1.11.1. Configuring the trip circuit supervision CMTCS_	65
5.1.12. Self-supervision (IRF)	65
5.1.12.1. Fault indication	66
5.1.12.2. Fault operation	66
5.1.12.3. Fault recovery	67
5.1.12.4. Fault codes	67
5.1.13. Serial communication	67
5.1.13.1. Serial communication port assignment	67
5.1.13.2. SPA/IEC_103 communication on the rear connector X3.2	68
5.1.13.3. DNP 3.0/Modbus communication on the rear connector X3.2	68
5.1.13.4. IEC 61850 communication by using SPA-ZC 400 on the rear connector X3.2	69
5.1.13.5. Profibus-DPV1 communication by using SPA-ZC 302 on the rear connector X3.2	69
5.1.13.6. LON/SPA bus communication on the rear connector X3.3	69
5.1.13.7. Front panel optical RS-232 connection for a PC	69
5.1.13.8. Communication parameters	70
5.1.13.9. Parallel communication support	74
5.1.13.10. System structure	74
5.1.13.11. LON inputs and outputs via a LON bus	80
5.1.13.12. Secured object control	81
5.1.14. Time synchronization	83
5.1.15. Display panel (HMI)	84
5.1.16. Alarm LED indicators	85
5.1.16.1. Non-latched alarm	86
5.1.16.2. Latched alarm, steady LED	86
5.1.16.3. Latched alarm, blinking LEDs	87
5.1.16.4. Interlocking	87
5.2. Design description	89
5.2.1. Technical data	89
5.2.2. Terminal diagram of REF 541	94
5.2.3. Terminal diagram of REF 543	95
5.2.4. Terminal diagram of REF 545	96
5.2.5. Terminal diagram of the RTD/analog module	97
5.2.6. Terminal connections	97

6. Service	101
7. Ordering Information	103
7.1. Order number	103
7.2. Hardware versions of REF 541, REF 543 and REF 545	104
7.3. Software configuration	104
8. Revision History of REF 54_	105
8.1. Revision identification	105
8.2. Release 1.5	106
8.2.1. Changes and additions to earlier released revisions	106
8.2.2. Configuration, setting and SA system tools	107
8.3. Release 2.0	107
8.3.1. Changes and additions to earlier released revisions	107
8.3.2. Configuration, setting and SA system tools	109
8.4. Release 2.5	110
8.4.1. Changes and additions to earlier released revisions	110
8.4.2. Configuration, setting and SA system tools	111
8.5. Release 3.0	111
8.5.1. Changes and additions to earlier released revisions	111
8.5.2. Configuration, setting and SA system tools	111
8.6. Release 3.5	111
8.6.1. Changes and additions to earlier released revisions	111
8.6.2. Configuration, setting and SA system tools	112
9. Appendix A: The IEC 60870-5-103 bus	113
9.1. Functions supported by REF 54_	113
9.2. IEC_103 parameters	114
9.3. The general principle of application data mapping	114
9.4. Class 2 data	115
9.5. Default mappings	115
10.Index	127

1. About this manual

1.1. Copyrights

The information in this document is subject to change without notice and should not be construed as a commitment by ABB Oy. ABB Oy assumes no responsibility for any errors that may appear in this document.

In no event shall ABB Oy be liable for direct, indirect, special, incidental or consequential damages of any nature or kind arising from the use of this document, nor shall ABB Oy be liable for incidental or consequential damages arising from use of any software or hardware described in this document.

This document and parts thereof must not be reproduced or copied without written permission from ABB Oy, and the contents thereof must not be imparted to a third party nor used for any unauthorized purpose.

The software or hardware described in this document is furnished under a license and may be used, copied, or disclosed only in accordance with the terms of such license.

Copyright © 2005 ABB Oy
All rights reserved.

1.2. Trademarks

ABB is a registered trademark of ABB Group.

All other brand or product names mentioned in this document may be trademarks or registered trademarks of their respective holders.

1.3. Guarantee

Please inquire about the terms of guarantee from your nearest ABB representative.

1.4. General

This document, REF 54_ Technical Reference Manual, General, provides a general technical description of the feeder terminals REF 541, REF 543 and REF 545.

Version N of the Technical Reference Manual complies with REF 54_ feeder terminals of Release 3.5. For information about the changes and additions included in REF 54_, Release 3.5 compared to earlier releases, refer to Section “Revision History of REF 54_” on page 105.

For detailed information about the separate protection and other functions listed in Section 5.1.1.1. , refer to the latest version of the CD-ROM “Technical Descriptions of Functions”.

1.5. Use of symbols

This publication includes warning, caution, and information icons that point out safety related conditions or other important information. It also includes tip icons to point out useful information to the reader. The corresponding icons should be interpreted as follows:



The warning icon indicates the presence of a hazard which could result in personal injury.



The caution icon indicates important information or warning related to the concept discussed in the text. It might indicate the presence of a hazard which could result in corruption of software or damage to equipment or property.



The information icon alerts the reader to relevant facts and conditions.

Although warning hazards are related to personal injury, and caution hazards are associated with equipment or property damage, it should be understood that operation of damaged equipment could, under certain operational conditions, result in degraded process performance leading to personal injury or death. Therefore, comply fully with all warning and caution notices.

1.6. Terminology

The following is a list of terms that you should be familiar with. The list contains terms that are unique to ABB or have a usage or definition that is different from standard industry usage.

Term	Description
IEC_103	IEC 60870-5-103, a communication protocol standardized by International Electrotechnical Commission
LONMark	An independent world-wide industry association, which facilitates the development and implementation of open, interoperable LONWorks based control products and systems.
MIMIC	A graphic configuration picture on the LCD of a relay
SPA	A data communication protocol developed by ABB
SPACOM	An ABB product family

1.7.

Abbreviations

Term	Description
AI	Analog Input
CB	Circuit Breaker
CBFP	Circuit Breaker Failure Protection
CPU	Central Processing Unit
CT	Current Transformer
DI	Digital Input
DNP	Distributed Network Protocol
DO	Digital Output
EMC	Electro-Magnetic Compatibility
GND	Ground
GOOSE	Generic Object Oriented Substation Event
HMI	Human-Machine Interface
HSPO	High-Speed Power Output
I/O	Input/Output
IRF	Internal Relay Fault
LCD	Liquid Crystal Display
LED	Light-Emitting Diode
LON	Locally Operating Network
L/R	Local/Remote
LV	Low Voltage
MV	Medium Voltage
NO/NC	Normally Open/ Normally Closed
PCB	Printed Circuit Board
PLC	Programmable Logic Controller
PMT	Protocol Mapping Tool
PO	Power Output
PS	Power Supply
RTD	Resistance Temperature Device
SNVT	Standard Network Variable Type
SO	Signal Output
SMS	Substation Monitoring System
TCR	Thermal Coefficient of Resistance
TCS	Trip Circuit Supervision
VT	Voltage Transformer



1.8. Related documents

Name of the manual	MRS number
General Manuals	
RE_ 5_ Installation Manual	1MRS750526-MUM
RE_ 54_ Operator's Manual	1MRS750500-MUM
Protection & Control Terminals REF 54_, RET 54_, REM 54_, REC 523 Configuration Guideline	1MRS750745-MUM
REF 54_, RET54_, REX 521 DNP 3.0 Communication Protocol, Technical Description	1MRS755260
REF 54_, RET54_ Modbus Communication Protocol, Technical Description	1MRS755238
Technical Descriptions of Functions (CD-ROM)	1MRS750889-MCD
Manuals for REF 54_	
Technical Reference Manual, General	1MRS750527-MUM
Parameter and event lists for REF 54_	
Parameter List for REF 541 and REF 543	1MRS751774-MTI
Parameter List for REF 545	1MRS751775-MTI
Event List for REF 541 and REF 543	1MRS751776-MTI
Event List for REF 545	1MRS751777-MTI
Manuals for related products	
RER 103 Bus Connection Module, Technical Description	1MRS750532-MUM
RER 123 Bus Connection Module, Technical Description	1MRS751143-MUM
RER 133 Bus Connection Module, Technical Description	1MRS755163
SPA-ZC 302 Profibus-DPV1/SPA Gateway, Installation and Commissioning Manual	1MRS755014
SPA-ZC 400 Ethernet Adapter, Installation and Commissioning Manual	1MRS755347
Tool-specific manuals	
CAP 501 Installation and Commissioning Manual	1MRS751899-MEN
CAP 501 User's Guide	1MRS751900-MUM
CAP 505 Installation and Commissioning Manual	1MRS751901-MEN
CAP 505 User's Guide	1MRS752292-MUM
CAP 505 Protocol Mapping Tool, Operation Manual	1MRS755277
CAP 505 Relay Mimic Editor, Configuration Guide	1MRS751904-MEN
LIB, CAP, SMS, Tools for Relays and Terminals, User's Guide	1MRS752008-MUM
LNT 505 Operator's manual	1MRS751706-MUM

1.9. Document revisions

Version	Date	History
K	15.09.03	Release 2.5: IEC 60870-5-103 support added. Virtual channel measurements added
M	02.04.04	Release 3.0: DNP 3.0 and Modbus support added. Time synchronization added
N	08.07.05	Release 3.5: FLOC and PQVO3Sd function blocks added
P	27.05.10	Document updated
R	21.10.10	Document updated

2. Safety information

	<p>Dangerous voltages can occur on the connectors, even though the auxiliary voltage has been disconnected.</p>
	<p>National and local electrical safety regulations must always be followed.</p>
	<p>The device contains components which are sensitive to electrostatic discharge. Unnecessary touching of electronic components must therefore be avoided.</p>
	<p>The frame of the device has to be carefully earthed.</p>
	<p>Only a competent electrician is allowed to carry out the electrical installation.</p>
	<p>Non-observance can result in death, personal injury or substantial property damage.</p>
	<p>Breaking the sealing tape on the rear panel of the device will result in loss of warranty and proper operation will no longer be guaranteed.</p>

3. Introduction

3.1. General

The REF 54_ feeder terminal is part of the ABB Distribution Automation system and extends the functionality and flexibility of the concept further. This is possible due to the modern technology applied both in hardware and software solutions.

Increased performance is achieved by utilizing the multiprocessor architecture. Digital signal processing combined with a powerful CPU and distributed I/O handling facilitates parallel operations and improves response times and accuracy. The HMI including an LCD display with different views makes the local use of the REF 54_ feeder terminal safe and easy. The HMI¹ instructs the user how to proceed.



A050370

Fig. 3.1.-1 REF 54_ feeder terminal

3.2. Hardware versions

The family of REF 54_ feeder terminals contains several hardware versions. Depending on the number of I/Os available, the product is called REF 541, REF 543 or REF 545, see the following tables.

1. HMI is referred to as MMI in the relay and in the Relay Setting Tool

Table 3.2.-1 Hardware versions of REF 541

HW modules	Order number																				
	REF541K_115AAAA	REF541K_115BAAA	REF541K_115CAAA	REF541K_115AABA	REF541K_115BABA	REF541K_115CABA	REF541K_115AAB	REF541K_115BAAB	REF541K_115ABB	REF541K_115BABB	REF541K_118AAAA	REF541K_118BAAA	REF541K_118CAAA	REF541K_118AABA	REF541K_118BABA	REF541K_118CABA	REF541K_118AAB	REF541K_118BAAB	REF541K_118ABB	REF541K_118BABB	
Analog interface																					
Sensor channels (current/ voltage)				9	9	9			9	9				9	9	9			9	9	
Current ratio /51 A	4	4	4	4	4	4	4	4	4	4	4	4	4	4	4	4	4	4	4	4	
Current ratio .201 A	1	1	1	1	1	1	1	1	1	1	1	1	1	1	1	1	1	1	1	1	
Voltage trafo 100 V	4	4	4	4	4	4	4	4	4	4	4	4	4	4	4	4	4	4	4	4	
Main processor boards																					
CPU module	1	1	1	1	1	1	1	1	1	1	1	1	1	1	1	1	1	1	1	1	
Power supply boards																					
PS1: 80...265 V AC/DC (High)		1			1			1		1					1			1		1	
PS1: 80...265 V AC/DC (Medium)	1			1			1		1		1				1			1		1	
PS1: 18...80 V DC (Low)			1			1							1			1					
PS2: 80...265 V AC/DC																					
PS2: 18...80 V DC																					
Digital I/O boards																					
BIO1: threshold voltage 155 V DC		1			1			1		1			1			1			1		1
BIO1: threshold voltage 80 V DC	1			1			1		1		1			1			1		1		
BIO1: threshold voltage 18 V DC			1			1							1			1					
BIO2: threshold voltage 155 V DC																					
BIO2: threshold voltage 80 V DC																					
BIO2: threshold voltage 18 V DC																					
Analog I/O board																					
RTD/analog module											1	1	1	1	1	1	1	1	1	1	1
Display boards																					
Graphic HMI display, fixed	1	1	1	1	1	1					1	1	1	1	1	1					
Graphic HMI display, external							1	1	1	1							1	1	1	1	1
Mechanic																					
1/2 enclosure	1	1	1	1	1	1	1	1	1	1	1	1	1	1	1	1	1	1	1	1	1
Digital inputs																					
	15									15											
Power outputs, single pole																					
	0									0											
Power outputs, double pole																					
	5									5											
Signal outputs (NO)																					
	2									2											
Signal outputs (NO/NC)																					
	5									5											
Supervised trip circuits																					
	2									2											
IRF outputs																					
	1									1											
RTD/analog inputs																					
	0									8											
Analog outputs																					
	0									4											

Table 3.2.-2 Hardware versions of REF 543

HW modules	Order number																			
	REF543K_127AAAA	REF543K_127BAAA	REF543K_127CAAA	REF543K_127AABA	REF543K_127BABA	REF543K_127CABA	REF543K_127AAAB	REF543K_127BAAB	REF543K_127AABB	REF543K_127BABB	REF543K_129AAAA	REF543K_129BAAA	REF543K_129CAAA	REF543K_129AABA	REF543K_129BABA	REF543K_129CABA	REF543K_129AAAB	REF543K_129BAAB	REF543K_129AABB	REF543K_129BABB
Analog interface																				
Sensor channels (current/voltage)				9	9	9			9	9				9	9	9			9	9
Current ratio /51 A	4	4	4	4	4	4	4	4	4	4	4	4	4	4	4	4	4	4	4	4
Current ratio .201 A	1	1	1	1	1	1	1	1	1	1	1	1	1	1	1	1	1	1	1	1
Voltage ratio 00 V	4	4	4	4	4	4	4	4	4	4	4	4	4	4	4	4	4	4	4	4
Main processor boards																				
CPU module	1	1	1	1	1	1	1	1	1	1	1	1	1	1	1	1	1	1	1	1
Power supply boards																				
PS1: 80...265 V AC/DC (High)		1			1			1		1				1				1		1
PS1: 80...265 V AC/DC (Medium)	1			1			1		1		1			1			1		1	
PS1: 18...80 V DC (Low)			1			1							1			1				
PS2: 80...265 V AC/DC																				
PS2: 18...80 V DC																				
Digital I/O boards																				
BIO1: threshold voltage 155 V DC		1			1			1		1			1			1			1	
BIO1: threshold voltage 80 V DC	1			1			1		1		1			1			1		1	
BIO1: threshold voltage 18 V DC			1			1							1			1				
BIO2: threshold voltage 155 V DC		1			1			1		1			1			1			1	
BIO2: threshold voltage 80 V DC	1			1			1		1		1			1			1		1	
BIO2: threshold voltage 18 V DC			1			1							1			1				
Analog I/O board																				
RTD/analog module											1	1	1	1	1	1	1	1	1	1
Display boards																				
Graphic HMI display, fixed	1	1	1	1	1	1					1	1	1	1	1	1				
Graphic HMI display, external							1	1	1	1							1	1	1	1
Mechanic																				
1/2 enclosure	1	1	1	1	1	1	1	1	1	1	1	1	1	1	1	1	1	1	1	1
Digital inputs																				
	25									25										
Power outputs, single pole																				
	2									2										
Power outputs, double pole																				
	9									9										
Signal outputs (NO)																				
	2									2										
Signal outputs (NO/NC)																				
	5									5										
Supervised trip circuits																				
	2									2										
IRF outputs																				
	1									1										
RTD/analog inputs																				
	0									8										
Analog outputs																				
	0									4										

Table 3.2.-3 Hardware versions of REF 545

HW modules	Order number									
	REF545K_133AAAA	REF545K_133BAAA	REF545K_133CAAA	REF545K_133AABA	REF545K_133BABA	REF545K_133CABA	REF545K_133AAB	REF545K_133BAAB	REF545K_133AABB	REF545K_133BABB
Analog interface										
Sensor channels (current/ voltage)				9	9	9			9	9
Current ratio /51 A	4	4	4	4	4	4	4	4	4	4
Current ratio .201 A	1	1	1	1	1	1	1	1	1	1
Voltage trafo 100 V	4	4	4	4	4	4	4	4	4	4
Main processor boards										
CPU module	1	1	1	1	1	1	1	1	1	1
Power supply boards										
PS1: 80...265 V AC/DC (High)										
PS1: 80...265 V AC/DC (Medium)										
PS1: 18...80 V DC (Low)										
PS2: 80...265 V AC/DC	1	1		1	1		1	1	1	1
PS2: 18...80 V DC			1			1				
Digital I/O boards										
BIO1: threshold voltage 155 V DC		2			2			2		2
BIO1: threshold voltage 80 V DC	2			2			2		2	
BIO1: threshold voltage 18 V DC			2			2				
BIO2: threshold voltage 155 V DC		1			1			1		1
BIO2: threshold voltage 80 V DC	1			1			1		1	
BIO2: threshold voltage 18 V DC			1			1				
Analog I/O board										
RTD/analog module										
Display boards										
Graphic HMI display, fixed	1	1	1	1	1	1				
Graphic HMI display, external							1	1	1	1
Mechanic										
1/2 enclosure	1	1	1	1	1	1	1	1	1	1
Digital inputs										
	34									
Power outputs, single pole										
	3									
Power outputs, double pole										
	11									
Signal outputs (NO)										
	4									
Signal outputs (NO/NC)										
	8									
Supervised trip circuits										
	2									
IRF outputs										
	1									
RTD/analog inputs										
	0									
Analog outputs										
	0									

4. Instructions

4.1. Application

The REF 54_ feeder terminals are designed to be used for the protection, control, measurement and supervision of medium voltage networks. They can be used with different kinds of switchgear including single busbar, double busbar and duplex systems. The protection functions also support different types of networks, such as isolated neutral networks, resonant-earthed networks and partially earthed networks.

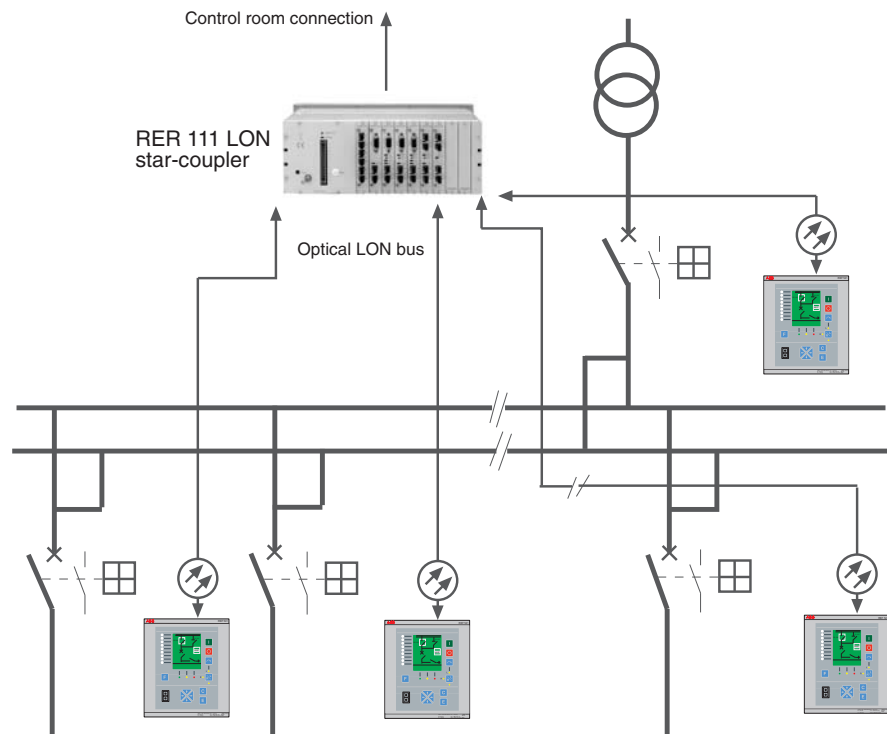

A050181

Fig. 4.1.-1 Distributed protection and control system based on REF 54_ feeder terminals

The functionality available for REF 54_ depends on the selected functionality level (refer to Section “Ordering Information” on page 103) and is also tied to the hardware configuration. The desired functions can be activated from a wide range of protection, control, measurement, power quality, condition monitoring, general and communication functions within the scope of I/O connections, considering the total CPU load. Compared to the traditional use of separate products, the combination of desired functions provides cost-effective solutions and, together with the relay configuration (IEC 61131-3 standard), allows the REF 54_ feeder terminals to be easily adapted to different kinds of applications.

By means of the graphic HMI display, the control functions in the feeder terminal indicate the position of disconnectors or circuit breakers locally. Further, the feeder terminal allows position information from the circuit breakers and the disconnectors to be transmitted to the remote control system. Controllable objects, such as CBs,

can be opened and closed over the remote control system. Position information and control signals are transmitted over the serial bus. Local control is also possible via the push-buttons on the front panel of the feeder terminal.

The feeder terminal is designed to be used for the selective short-circuit and earth-fault protection. The feeder protection type REF 54_ includes overcurrent and earth-fault functions and is used for feeder short-circuit, time overcurrent and earth-fault protection in solidly, resistant or resonant-earthed networks and in isolated neutral networks. When desired, auto-reclosing is achieved by using the auto-reclose function. Up to five successive auto-reclose cycles can be carried out. For an example application with basic functions, see Fig. 4.1.-2 below.

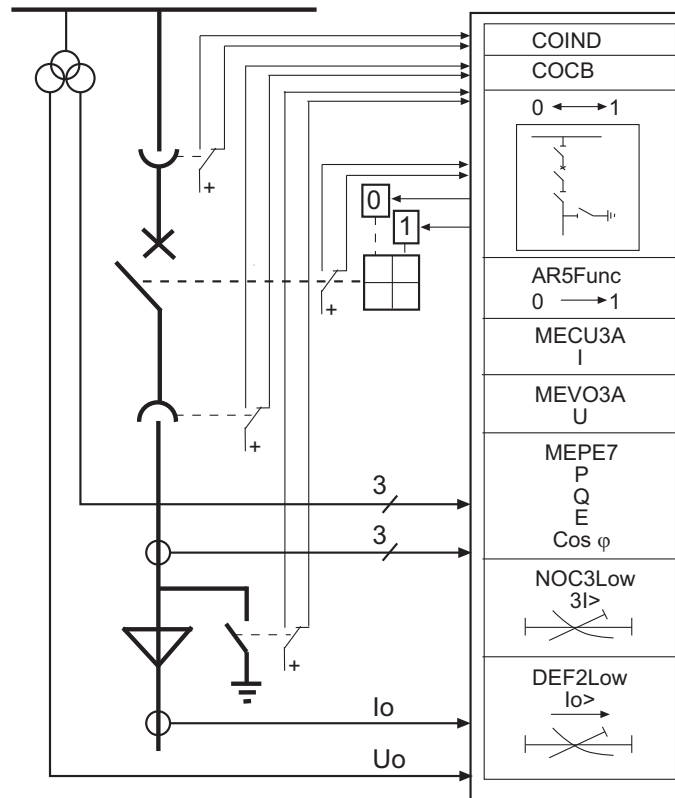

A050182

Fig. 4.1.-2 Basic functions of the integrated feeder terminal REF 54_

In addition, REF 54_ offers protection functions for a large variety of applications, such as frequency and voltage based protection, motor protection, thermal overload protection, capacitor bank protection and synchro-check/voltage check function.

The REF 54_ terminal measures phase currents, phase-to-phase or phase-to-earth voltages, neutral current, residual voltage, frequency and power factor. Active and reactive power is calculated from measured currents and voltages. Energy can be calculated on the basis of the measured power. The measured values can be indicated locally and remotely as scaled primary values.

With the condition monitoring functions the REF 54_ feeder terminal monitors for example gas pressure and breaker wear, registers the operate time and provides scheduled time intervals for maintenance.

In addition to protection, measurement, control and condition monitoring functions, the feeder terminals are provided with a large amount of PLC functions allowing several automation and sequence logic functions needed for substation automation to be integrated into one unit. The data communication properties include SPA bus communication, LON bus communication, IEC 60870-5-103¹ communication, DNP 3.0 communication or Modbus communication with higher-level equipment. Further, LON communication, together with PLC functions, minimizes the need for hardwiring between the units.

4.2. Requirements

If the environmental conditions differ from those specified in section “Technical data”, as to temperature and humidity, or if the atmosphere around the feeder terminal contains chemically active gases or dust, the terminal should be visually inspected in association with the secondary testing. The visual inspection should focus on:

- signs of mechanical damage to the feeder terminal case and terminals,
- dust on the feeder terminal cover or case, and
- signs of corrosion on terminals, on the case or inside the feeder terminal.

For information about the maintenance of feeder terminals, refer to Section “Service” on page 101.



Feeder terminals are measuring instruments and should be handled with care and protected against moisture and mechanical stress, especially during transport.

4.3. Terminal configuration

The REF 54_ feeder terminals are adapted to specific applications by using the Relay Configuration Tool included in the CAP 505 tools. This tool is used for configuring the basic terminal, protection and logic function blocks, control and measurement functions, timers and other functional elements included in the logic functions category (refer to Section “Feeder terminal configuration” on page 28).

The MIMIC picture, alarm texts and LED indicators are configured with the Relay Mimic Editor (refer to Section “MIMIC configuration” on page 29).

The configuration of LON network is described in section “LON network configuration” on page 31. If the application includes no horizontal communication, network variables are not needed and the section about LON network configuration is thus not relevant.

The customer can configure the REF 54_ feeder terminal according to own functional requirements and preferences or utilize the pre-engineered configuration solutions.

For more detailed information about the configuration, refer to the Configuration Guideline and the tool-specific manuals (refer to Section “Related documents” on page 10).

1. IEC 60870-5-103 later referred as IEC_103.

5. Technical Description

5.1. Functional description

5.1.1. Functions of the feeder terminal

The functions of the REF 54_ feeder terminal are categorized as:

- Protection functions
- Measurement functions
- Power quality functions
- Control functions
- Condition monitoring functions
- Communication functions
- General functions
- Standard functions

The functions are further divided to three subsets that correspond to different functionality levels (refer to Section “Ordering Information” on page 103).

All function blocks are documented on the CD-ROM “Technical Descriptions of Functions”, refer to Section “Related documents” on page 10 for more information.

The function blocks of the terminal are listed in Tables 5.1.1.1-1 to 5.1.1.8-1,. If the ANSI device no. and IEC symbol columns are missing from a table, the function block uses the same symbol in the ANSI and IEC modes as stated in the Function column.

5.1.1.1. Protection functions

Protection is one of the most important functions of the REF 54_ feeder terminal. The protection function blocks (for example NOC3Low) are independent of each other and have their own setting groups and data recording. The non-directional overcurrent protection includes the three stages NOC3Low, NOC3High and NOC3Inst, each with independent protection functions.

Either Rogowski coils or conventional current transformers can be used for protection functions based on current measurement. Correspondingly, voltage dividers or voltage transformers are used for protection functions based on voltage measurement.

Table 5.1.1.1-1 Protection functions available for REF 54_

Function	ANSI device no.	IEC symbol	Description
AR5Func	79	O-->I	Auto-reclose function (5 shots)
CUB1Cap ²⁾	51NC-1	dI>C	Current unbalance protection for shunt capacitor banks
CUB3Cap ³⁾	51NC-2	3dI>C	Three-phase current unbalance protection for H-bridge connected shunt capacitor
CUB3Low	46	Iub>	Phase discontinuity protection
DEF2Low	67N-1	Io>-->	Directional earth-fault protection, low-set stage
DEF2High	67N-2	Io>>-->	Directional earth-fault protection, high-set stage
DEF2Inst	67N-3	Io>>>-->	Directional earth-fault protection, instantaneous stage

Technical Reference Manual, General

Table 5.1.1.1-1 Protection functions available for REF 54_ (Continued)

Function	ANSI device no.	IEC symbol	Description
DOC6Low ¹⁾	67-1	3I>-->	Three-phase directional overcurrent protection, low-set stage
DOC6High ¹⁾	67-2	3I>>-->	Three-phase directional overcurrent protection, high-set stage
DOC6Inst ¹⁾	67-3	3I>>>-->	Three-phase directional overcurrent protection, instantaneous stage
FLOC ⁴⁾	21FL	FLOC	Fault locator
Freq1St1 ¹⁾	81-1	f1	Underfrequency or overfrequency protection, stage 1
Freq1St2 ¹⁾	81-2	f2	Underfrequency or overfrequency protection, stage 2
Freq1St3 ¹⁾	81-3	f3	Underfrequency or overfrequency protection, stage 3
Freq1St4 ¹⁾	81-4	f4	Underfrequency or overfrequency protection, stage 4
Freq1St5 ¹⁾	81-5	f5	Underfrequency or overfrequency protection, stage 5
FuseFail ³⁾	60	FUSEF	Fuse failure supervision
Inrush3	68	3I2f>	Three-phase transformer inrush and motor start-up current detector
MotStart ²⁾	28	Is2t n<	Three-phase start-up supervision for motors
NEF1Low	51N-1	Io>	Non-directional earth-fault protection, low-set stage
NEF1High	51N-2	Io>>	Non-directional earth-fault protection, high-set stage
NEF1Inst	51N-3	Io>>>	Non-directional earth-fault protection, instantaneous stage
NOC3Low	51-1	3I>	Three-phase non-directional overcurrent protection, low-set stage
NOC3High	51-2	3I>>	Three-phase non-directional overcurrent protection, high-set stage
NOC3Inst	51-3	3I>>>	Three-phase non-directional overcurrent protection, instantaneous stage
OL3Cap ²⁾	51C	3I>3I<	Three-phase overload protection for shunt capacitor banks
OV3Low	59-1	3U>	Three-phase overvoltage protection, low-set stage
OV3High	59-2	3U>>	Three-phase overvoltage protection, high-set stage
PSV3St1 ²⁾	47-1	U1U2<>_1	Phase-sequence voltage protection, stage 1
PSV3St2 ²⁾	47-2	U1U2<>_2	Phase-sequence voltage protection, stage 2
ROV1Low	59N-1	Uo>	Residual overvoltage protection, low-set stage
ROV1High	59N-2	Uo>>	Residual overvoltage protection, high-set stage
ROV1Inst	59N-3	Uo>>>	Residual overvoltage protection, instantaneous stage
SCVCS1 ¹⁾	25-1	SYNC1	Synchro-check / voltage-check function, stage 1
SCVCS2 ¹⁾	25-2	SYNC2	Synchro-check / voltage-check function, stage 2
TOL3Cab ¹⁾	49F	3Ith>	Three-phase thermal overload protection for cables
TOL3Dev ²⁾	49M/G/T	3Ithdev>	Three-phase thermal overload protection for devices
UV3Low	27-1	3U<	Three-phase undervoltage protection, low-set stage
UV3High	27-2	3U<<	Three-phase undervoltage protection, high-set stage

1) These functions are only supported in the feeder terminal revisions of Release 1.5 or later.

2) These functions are only supported in the feeder terminal revisions of Release 2.0 or later.

3) These functions are only supported in the feeder terminal revisions of Release 2.5 or later.

4) This function is only supported in the feeder terminal revisions of Release 3.5 or later.

Refer to Section "Revision identification" on page 105 for more information.

5.1.1.2. Measurement functions

Table 5.1.1.2-1 Measurement functions available for REF 54_

Function	ANSI device no.	IEC symbol	Description
MEAI1 ²⁾	AI1	AI1	General measurement 1 / analog input on RTD/analog module
MEAI2 ²⁾	AI2	AI2	General measurement 2 / analog input on RTD/analog module
MEAI3 ²⁾	AI3	AI3	General measurement 3 / analog input on RTD/analog module
MEAI4 ²⁾	AI4	AI4	General measurement 4 / analog input on RTD/analog module
MEAI5 ²⁾	AI5	AI5	General measurement 5 / analog input on RTD/analog module
MEAI6 ²⁾	AI6	AI6	General measurement 6 / analog input on RTD/analog module
MEAI7 ²⁾	AI7	AI7	General measurement 7 / analog input on RTD/analog module
MEAI8 ²⁾	AI8	AI8	General measurement 8 / analog input on RTD/analog module
MEAO1 ²⁾	AO1	AO1	Analog output 1 on RTD/analog module
MEAO2 ²⁾	AO1	AO1	Analog output 2 on RTD/analog module
MEAO3 ²⁾	AO3	AO3	Analog output 3 on RTD/analog module
MEAO4 ²⁾	AO4	AO4	Analog output 4 on RTD/analog module
MECU1A	Io	Io	Neutral current measurement, stage A
MECU1B	Io_B	Io_B	Neutral current measurement, stage B
MECU3A	3I	3I	Three-phase current measurement, stage A
MECU3B ²⁾	3I_B	3I_B	Three-phase current measurement, stage B
MEDREC16 ¹⁾	DREC	DREC	Transient disturbance recorder
MEFR1	f	f	System frequency measurement
MEPE7	PQE	PQE	Three-phase power and energy measurement
MEVO1A	Uo	Uo	Residual voltage measurement, stage A
MEVO1B ²⁾	Uo_B	Uo_B	Residual voltage measurement, stage B
MEVO3A	3U	3U	Three-phase voltage measurement, stage A
MEVO3B ²⁾	3U_B	3U_B	Three-phase voltage measurement, stage B

1) These functions are only supported in the feeder terminal revisions of Release 1.5 or later.

2) These functions are only supported in the feeder terminal revisions of Release 2.0 or later. Refer to Section "Revision identification" on page 105 for more information.

5.1.1.3. Power quality functions

Table 5.1.1.3-1 Power quality functions available for REF 54_

Function	ANSI device no.	IEC symbol	Description
PQCU3H ¹⁾	PQ 3Inf	PQ 3Inf	Current waveform distortion measurement
PQVO3H ¹⁾	PQ 3Unf	PQ 3Unf	Voltage waveform distortion measurement
PQVO3Sd ²⁾	PQ 3U<>	PQ 3U<>	Short duration voltage variations

1) These functions are only supported in the feeder terminal revisions of Release 2.0 or later.

2) This function is only supported in the feeder terminal revisions of Release 3.5 or later. Refer to Section "Revision identification" on page 105 for more information.

5.1.1.4. Control functions

The control functions are used to indicate the position of switching devices, that is, circuit breakers and disconnectors, and to execute open and close commands for controllable switching devices in the switchgear. Furthermore, there are supplementary functions for control logic purposes, such as on/off switches, MIMIC alarm, LED control, numerical data for the MIMIC and logic controlled position selection.

The control functions configured using the Relay Configuration Tool can be associated with position indicators that are part of the MIMIC configuration picture displayed on the HMI. Position indicators are used to indicate the position of switching devices via the MIMIC picture and to control them locally. For more information about the MIMIC configuration, refer to Section “MIMIC configuration” on page 29.

Table 5.1.1.4-1 Control functions available for REF 54_

Function	ANSI device no.	IEC symbol	Description
CO3DC1	CO3DC1	I<->O 3DC1	Three-state disconnector (1) with indication
CO3DC2	CO3DC2	I<->O 3DC2	Three-state disconnector (2) with indication
COCB1	COCB1	I<->O CB1	Circuit breaker 1 control with indication
COCB2	COCB2	I<->O CB2	Circuit breaker 2 control with indication
COCBDIR	COCBDIR	CBDIR	Direct open for CBs via HMI
CODC1	CODC1	I<->O DC1	Disconnector 1 control with indication
CODC2	CODC2	I<->O DC2	Disconnector 2 control with indication
CODC3	CODC3	I<->O DC3	Disconnector 3 control with indication
CODC4	CODC4	I<->O DC4	Disconnector 4 control with indication
CODC5	CODC5	I<->O DC5	Disconnector 5 control with indication
COIND1	COIND1	I<->O IND1	Switching device 1 indication
COIND2	COIND2	I<->O IND2	Switching device 2 indication
COIND3	COIND3	I<->O IND3	Switching device 3 indication
COIND4	COIND4	I<->O IND4	Switching device 4 indication
COIND5	COIND5	I<->O IND5	Switching device 5 indication
COIND6	COIND6	I<->O IND6	Switching device 6 indication
COIND7	COIND7	I<->O IND7	Switching device 7 indication
COIND8	COIND8	I<->O IND8	Switching device 8 indication
COLOCAT	COLOCAT	I<->O POS	Logic-controlled control position selector
COPFC ¹⁾	55	COPFC	Power factor controller
COSW1	COSW1	SW1	On/off switch 1
COSW2	COSW2	SW2	On/off switch 2
COSW3	COSW3	SW3	On/off switch 3
COSW4	COSW4	SW4	On/off switch 4
MMIALAR1	ALARM1	ALARM1	Alarm channel 1, LED indicator
MMIALAR2	ALARM2	ALARM2	Alarm channel 2, LED indicator
MMIALAR3	ALARM3	ALARM3	Alarm channel 3, LED indicator
MMIALAR4	ALARM4	ALARM4	Alarm channel 4, LED indicator
MMIALAR5	ALARM5	ALARM5	Alarm channel 5, LED indicator
MMIALAR6	ALARM6	ALARM6	Alarm channel 6, LED indicator
MMIALAR7	ALARM7	ALARM7	Alarm channel 7, LED indicator
MMIALAR8	ALARM8	ALARM8	Alarm channel 8, LED indicator

Technical Reference Manual, General

Table 5.1.1.4-1 Control functions available for REF 54_ (Continued)

Function	ANSI device no.	IEC symbol	Description
MMIDATA1	MMIDATA1	MMIDATA1	MIMIC data monitoring point 1
MMIDATA2	MMIDATA2	MMIDATA2	MIMIC data monitoring point 2
MMIDATA3	MMIDATA3	MMIDATA3	MIMIC data monitoring point 3
MMIDATA4	MMIDATA4	MMIDATA4	MIMIC data monitoring point 4
MMIDATA5	MMIDATA5	MMIDATA5	MIMIC data monitoring point 5

1) This function is only supported in the feeder terminal revisions of Release 2.0 or later, refer to Section "Revision identification" on page 105.

5.1.1.5. Condition monitoring functions

Table 5.1.1.5-1 Condition monitoring functions available for REF 54_

Function	ANSI device no.	IEC symbol	Description
CMBWEAR1	CB wear1	CB wear1	Circuit-breaker electric wear 1
CMBWEAR2	CB wear2	CB wear2	Circuit-breaker electric wear 2
CMCU3	MCS 3I	MCS 3I	Supervision function of the energizing current input circuit
CMGAS1	CMGAS1	GAS1	Gas pressure monitoring
CMGAS3 ¹⁾	CMGAS3	GAS3	Three-pole gas pressure monitoring
CMSCHED	CMSCHED	SCHED	Scheduled maintenance
CMSPRC1	CMSPRC1	SPRC1	Spring charging control 1
CMTCS1	TCS1	TCS1	Trip circuit supervision 1
CMTCS2	TCS2	TCS2	Trip circuit supervision 2
CMTIME1	TIME1	TIME1	Operate time counter 1 for the operate time used (e.g. motors)
CMTIME2	TIME2	TIME2	Operate time counter 2 for the operate time used (e.g. motors)
CMTRAV1	CMTRAV1	TRAV1	Breaker travel time 1
CMVO3	MCS 3U	MCS 3U	Supervision function of the energizing voltage input circuit

1) This function is only supported in the feeder terminal revisions of Release 2.0 or later, refer to Section "Revision identification" on page 105.

5.1.1.6. Communication functions

The REF 54_ feeder terminal provides the IEC_103, Modbus, DNP 3.0, SPA and LON serial communication protocols.

In a customer-specific feeder terminal configuration, special events can be generated via an EVENT230 event function.

For more information about communication in the REF 54_ feeder terminal, refer to Section "Serial communication" on page 67.

5.1.1.7.

General functions**Table 5.1.1.7-1 General functions available for REF 54_**

Function	Description
INDRESET	Resetting of operation indicators, latched output signals, registers and waveforms, for example the disturbance recorder
MMIWAKE	Activation of HMI backlight
SWGRP1	Switchgroup SWGRP1
SWGRP2	Switchgroup SWGRP2
SWGRP3	Switchgroup SWGRP3
.....	
SWGRP20	Switchgroup SWGRP20

5.1.1.8.

Standard functions

Standard functions are used for logics, such as interlocking, alarming and control sequencing. The use of logic functions is not limited and the functions can be interconnected with each other as well as with protection, measurement, power quality, control, condition monitoring and general functions. In addition, the digital inputs and outputs as well as LON inputs and outputs can be connected to standard functions by using the Relay Configuration Tool.

Table 5.1.1.8-1 Standard functions available for REF 54_

Function	Description
ABS	Absolute value
ACOS	Principal arc cosine
ADD	Extensible adder
AND	Extensible AND connection
ASIN	Principal arc sine
ATAN	Principal arc tangent
BITGET	Get one bit
BITSET	Set one bit
BOOL_TO_*	Type conversion from BOOL to WORD / USINT / UINT / UDINT / SINT / REAL / INT / DWORD / DINT / BYTE
BOOL2INT	Type conversion from BOOL inputs to INT output
BYTE_TO_*	Type conversion from BYTE to WORD / DWORD
COMH	Hysteresis comparator
COS	Cosine in radians
CTD	Down-counter
CTUD	Up-down counter
CTU	Up-counter
DATE_TO_UDINT	Type conversion from DATE to UDINT
DINT_TO_*	Type conversion from DINT to SINT / REAL / INT
DIV	Divider
DWORD_TO_*	Type conversion from DWORD to WORD / BYTE
EQ	Extensible comparison to equal
EXP	Natural exponential
EXPT	Exponentiation
F_TRIG	Falling edge detector
GE	Extensible comparison to greater or equal

Technical Reference Manual, General

Table 5.1.1.8-1 Standard functions available for REF 54_ (Continued)

Function	Description
GT	Extensible comparison to greater
INT_TO_*	Type conversion from INT to REAL / DINT
INT2BOOL	Type conversion from INT input to BOOL outputs
LE	Extensible comparison to less or equal
LIMIT	Limitation
LN	Natural logarithm
LOG	Logarithm base 10
LT	Extensible comparison to less
MAX	Extensible maximum
MIN	Extensible minimum
MOD	Modulo
MOVE	Move
MUL	Extensible multiplier
MUX	Extensible multiplexer
NE	Comparison to greater or less
NOT	Complement
OR	Extensible OR connection
R_TRIG	Rising edge detector
REAL_TO_*	Type conversion from REAL to USINT / UINT / UDINT / SINT / INT / DINT
ROL	Rotate to left
ROR	Rotate to right
RS	Reset dominant bistable function block
RS_D	Reset dominant bistable function block with data input
SEL	Binary selection
SHL	Bit-shift to left
SHR	Bit-shift to right
SIN	Sine in radians
SINT_TO_*	Type conversion from SINT to REAL / INT / DINT
SUB	Subtractor
SQRT	Square root
SR	Set dominant bistable function block
XOR	Extensible exclusive OR connection
TAN	Tangent in radians
TIME_TO_*	Type conversion from TIME to UDINT / TOD / REAL
TOD_TO_*	Type conversion from TOD to UDINT / TIME / REAL
TOF Of	f-delay timer
TON On-delay	timer
TP	Pulse
TRUNC_*	Truncation toward zero
UDINT_TO_*	Type conversion from UDINT to USINT / UINT / REAL
UINT_TO_*	Type conversion from UINT to USINT / UDINT / REAL / BOOL
USINT_TO_*	Type conversion from USINT to UINT / UDINT / REAL
WORD_TO_*	Type conversion from WORD to DWORD / BYTE

5.1.2. Configuration

5.1.2.1. Feeder terminal configuration

The Relay Configuration Tool is based on the IEC 61131-3 standard. The standard defines the programming language used for the configuration. The programmable system of REF 54_ feeder terminals allows the output contacts to be operated in accordance with the state of the logic inputs and the outputs of the protection, control, measurement and condition monitoring functions. The PLC functions (such as interlocking and alarm logic) are programmed with Boolean functions, timers, counters, comparators and flip-flops. The program is written in a function block diagram language by using the configuration software.

After the configuration has been built and successfully compiled, and the MIMIC configuration has been designed, the Relay Configuration Tool project (RCT project in CAP 505) including the relay configuration and MIMIC configuration can be downloaded to the relay with the Relay Download Tool. The project can also be uploaded from the feeder terminal with the same tool¹. However, the relay configuration, the RCT project and the MIMIC configuration are saved in a non-volatile memory only after they have been stored via the parameter “Store”. To activate new configurations, the feeder terminal should be reset via the parameter “Software reset”. These parameters can be found in the menu *Configuration/General*. Likewise, the storing and the resetting can be done by using the relay command buttons “Store” and “Reset” in the Relay Download Tool.

For more information about the configuration and the Relay Configuration Tool, refer to the Configuration Guideline and the tool manuals (refer to Section “Related documents” on page 10).

1. This function is only supported in the feeder terminal revisions of Release 2.0 or later, refer to Section “Revision identification” on page 105.

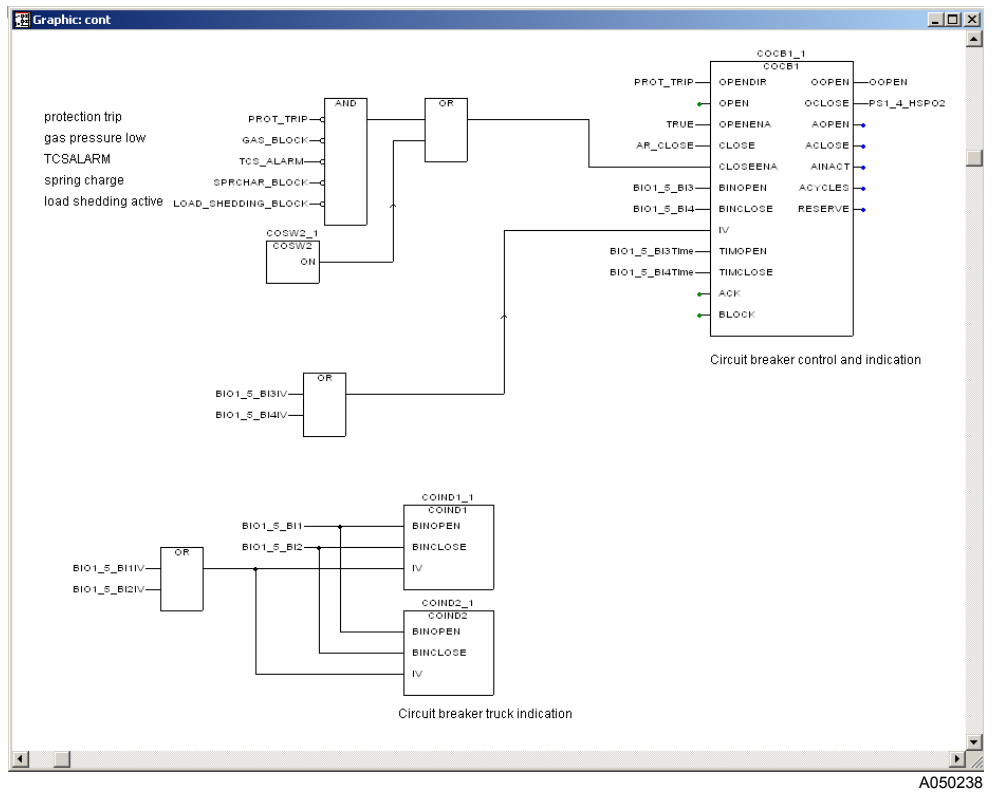

Fig. 5.1.2.1.-1 Example of a feeder terminal configuration with the Relay Configuration Tool

5.1.2.2.

MIMIC configuration

The control functions configured using the Relay Configuration Tool can be associated with position indicators that are part of the MIMIC configuration picture displayed on the graphic LCD of the HMI. The MIMIC configuration picture is designed with the Relay Mimic Editor. In addition, the editor is used to define the eight programmable LED indicators and the corresponding alarm texts on the front panel, the alarm modes, and the interlocking LED texts.

The MIMIC picture may include a single-line diagram, measured values with units, free texts, and so on. The position indicators (open, closed, undefined) are drawn according to the customer's requirements. Note that the operation of the objects themselves is determined by means of the Relay Configuration Tool.

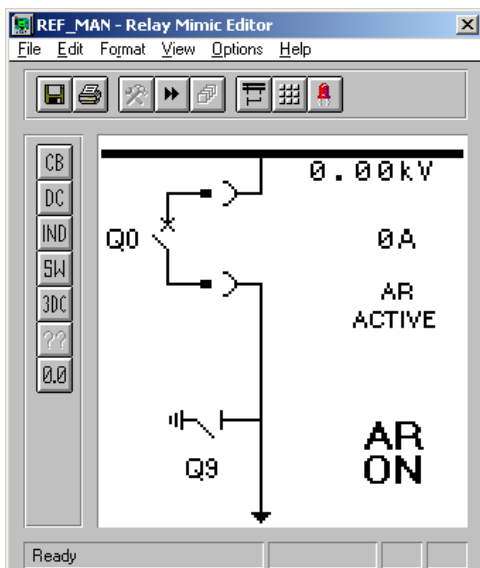

A050239

Fig. 5.1.2.2.-1 MIMIC configuration with the Relay Mimic Editor

The content of the alarm view is configured with the Relay Mimic Editor by defining the ON and OFF state texts (max 16 characters), see Fig. 5.1.2.2.-2 below. For defining the corresponding LED colors, refer to Section “Alarm LED indicators” on page 85.

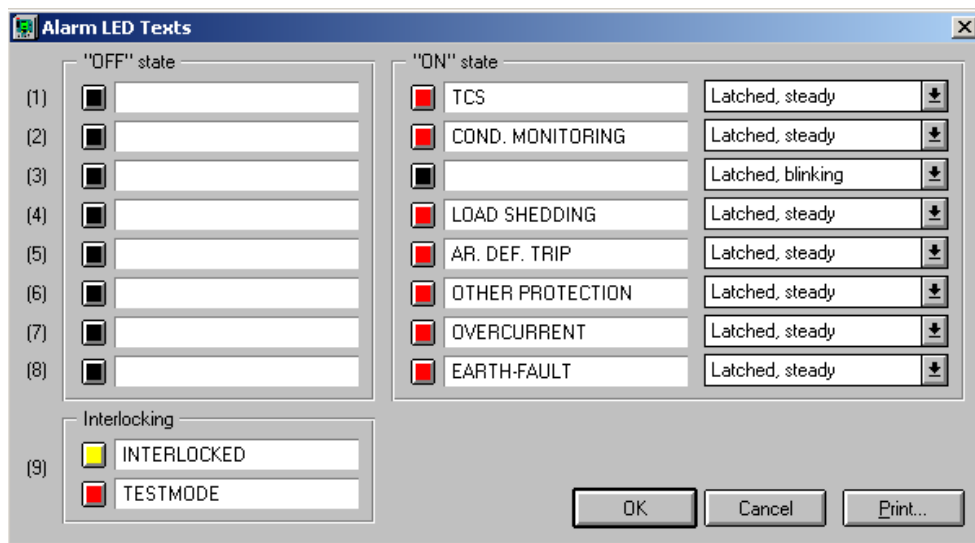

A050240

Fig. 5.1.2.2.-2 Alarm channel configuration

Interlocking LED texts can also be defined in the view illustrated above, but the interlocking LED colors cannot be changed. For the operation of the interlocking LED, refer to Section “Interlocking” on page 87.



For more information about the use of the editor, refer to the Relay Mimic Editor manual (refer to Section “Related documents” on page 10).

5.1.2.3.

LON network configuration

The LON Network Tool is used for binding network variables between RED 500 terminals. Typically, LON is used for transferring status data between the terminals for interlocking sequences running in the units, see Fig. 5.1.2.3.-1 below and Fig. 5.1.13.10.-1 on page 80.

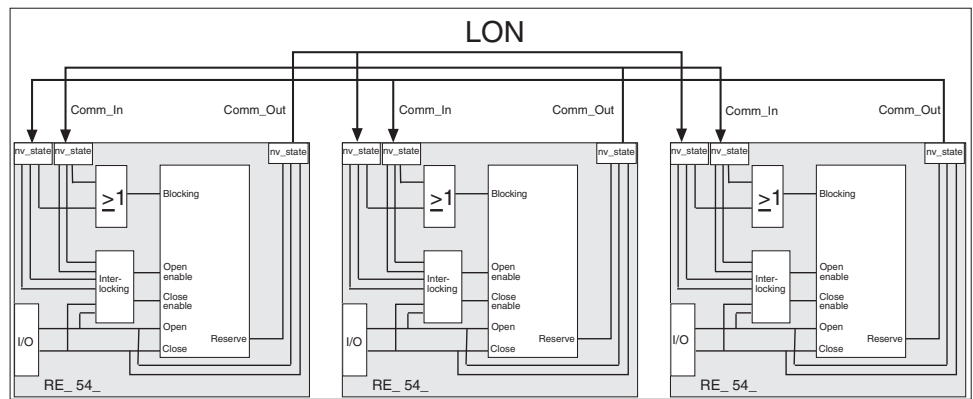

A050183

Fig. 5.1.2.3.-1 Communication between RED 500 terminals in station interlocking



For more information about the use of the tool, refer to the LNT 505 Operator’s Manual (refer to Section “Related documents” on page 10).

5.1.2.4.

DNP 3.0 and Modbus configuration

Protocol Mapping Tool (PMT) is used for DNP 3.0 and Modbus configuration. PMT is integrated in CAP 505. For more information about PMT, refer to CAP 505 Protocol Mapping Tool, Operation Manual (refer to Section “Related documents” on page 10).

5.1.2.5.

Rated frequency

The rated frequency of the feeder terminal is set in association with configuration via a dialog box in the Relay Configuration Tool. The set rated frequency cannot be changed afterwards via the HMI or serial communication, but it can be read via the global control parameter “Rated frequency” of the feeder terminal.

5.1.3. Parameters and events

The function blocks and I/O cards include a large number of parameters and events. In addition, general parameters and events are provided, such as parameters for control and communication as well as events for testing and self-supervision.

The function block specific parameters are listed in each function block description. Moreover, all parameters and events for REF 54_ are listed in the parameter and event lists. The function block descriptions as well as the parameter and event lists are included on the CD-ROM “Technical Descriptions of Functions” (refer to Section “Related documents” on page 10).

5.1.4. Parameterization

To ensure that a protection function block protects the feeder in the desired manner, the default values of parameters are to be checked and properly set before taking the function block into use.

The parameters can be set either locally over the HMI or externally via the serial communication.

5.1.4.1. Local parameterization

When the parameters are set locally via the HMI, the setting parameters can be chosen from the hierarchical menu structure. The desired language for parameter description can also be selected. Detailed information about setting and navigation is found in the RE_ 54_ Operator’s Manual.

5.1.4.2. External parameterization

The Relay Setting Tool is used for parameterization and setting the REF 54_ feeder terminals externally. The parameters can be set off-line on a PC and downloaded to the feeder terminal over a communication port. The menu structure of the setting tool, including views relating to parameterization and settings, is the same as the menu structure of the feeder terminal.



The use of the tool is instructed in the manual “LIB, CAP, SMS, Tools for Relays and Terminals, User’s Guide” (refer to Section “Related documents” on page 10).

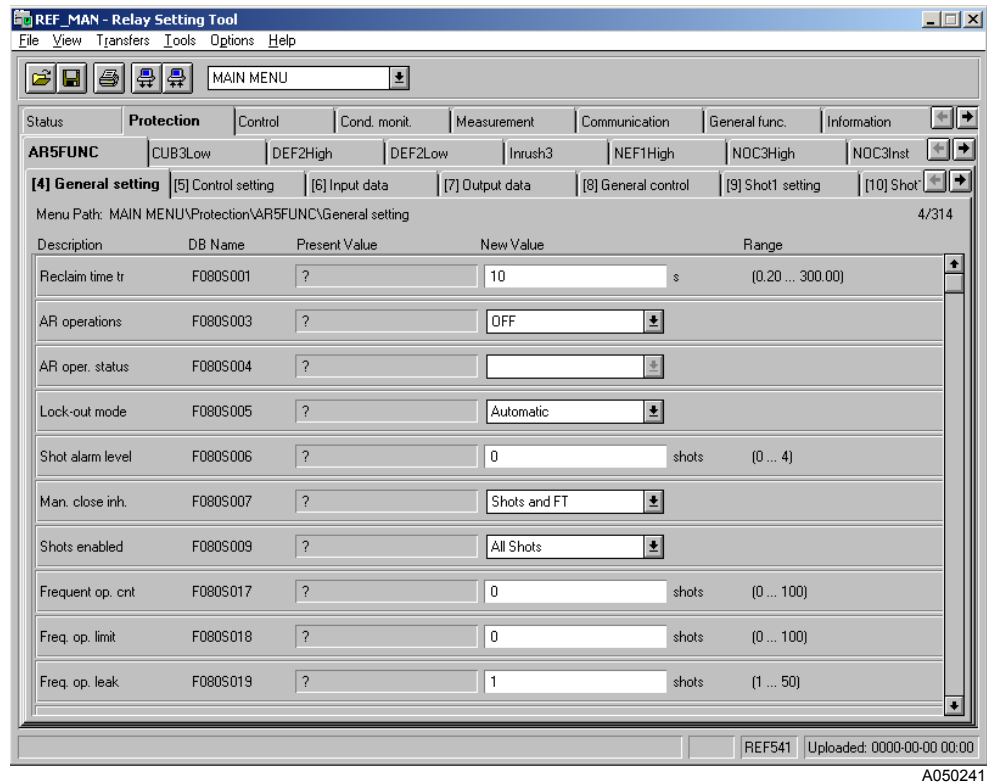

A050241

Fig. 5.1.4.2.-1 Main dialog box of the Relay Setting Tool

5.1.4.3.

Storing of parameters and recorded data

When parameter values are changed, the new values take effect immediately. However, the new parameter values as well as the recorded data are saved in a non-volatile memory only after they have been stored via the parameter “Store” in the menu Configuration/General (refer to the Operator’s Manual) or in the relay tools. Provided the storing was completed successfully, the information stored in the non-volatile memory is preserved in the memory also in case of a power interruption. During the storing procedure, it is not possible to reset the feeder terminal via the parameter “Software reset” or to load a new project.



When the values for the measuring devices (refer to sections “Scaling the rated values of the protected unit for analog channels” on page 38 and “Technical data of the measuring devices” on page 39) are changed via the HMI or the Relay Setting Tool, the new values take effect only after they have been stored via the parameter “Store” and the feeder terminal has been reset via the parameter “Software reset” in the menu Configuration/General or by using the relay command buttons “Store” and “Reset” in the Relay Download Tool.

The same applies for some communication parameters, i.e. the SPA baud rate, most Modbus parameters, the IEC_103 protocol RTD data frame parameter, the protocol selection parameters (Protocol 2 and Protocol 3 in the menu Communication/General) and the command timeout parameter in the menu Communication/General.

5.1.5. Auxiliary voltage

For its operation the REF 54_ terminal, including the external display module, requires a secured auxiliary voltage supply. The feeder terminal’s internal power supply module forms the voltages required by the feeder terminal electronics. The power supply module is a galvanically isolated (flyback-type) DC/DC converter. A green protection LED indicator on the front panel is lit when the power supply module is in operation.



The main unit and the external display module must each be provided with separate power supply from a common source.

The feeder terminal is provided with a 48-hour capacitor back-up protection¹ that enables the internal clock to keep time in case of an auxiliary power failure.

5.1.5.1. Power supply versions

There are two basic types of power supply modules available for the REF 54_ feeder terminals: type PS1/_ and type PS2/_. The module PS1/_ is used in REF 541 and REF 543 terminals. The module PS2/_ is intended for the REF 545 terminal. Both modules are available in two versions: PS1/48 V, PS1/240 V, PS2/48 V, PS2/240 V.

There are also differences in the threshold voltages of the power supply modules’ digital inputs. PS1/_ has three different alternatives for threshold voltage of the binary inputs: low, medium and high version. The threshold voltage of the low version is 18 V DC, medium version 80 V DC and high version 155 V DC. The module PS1/48 V is a low version power supply and PS1/240 V is a medium or high version. The type PS2/_ does not have binary inputs.

Table 5.1.5.1-1 Power supply modules and their rated input voltages

Power supply module	Rated input voltage of power supply	Rated input voltage of digital inputs
PS1/240 V (High)	110/120/220/240 V AC or 110/125/220 V DC	220 V DC
PS1/240 V (Medium)	110/120/220/240 V AC or 110/125/220 V DC	110/125/220 V DC
PS1/48 V (Low)	24/48/60 V DC	24/48/60/110/125/220 V DC
PS2/240 V	110/120/220/240 V AC or 110/125/220 V DC	-
PS2/48	24/48/60 V DC	-
External display module	110/120/220/240 V AC or 110/125/220 V DC	-

When REF 54_ is delivered with a fixed display module, the input voltage range of the power supply module is marked on the front panel of the feeder terminal. When the feeder terminal is provided with an external display module, the input voltage of the display module is marked on the front panel of the module and the input voltage of the main unit is marked on the side of the unit.

1. This function is only supported in the feeder terminal revisions of Release 2.0 or later, refer to Section “Revision identification” on page 105.

The external display module is only available together with a main unit equipped with the PS_/240 power supply module.

The power supply version is specified by the first letter in the order number of REF 54_ (refer to Section “Ordering Information” on page 103). The voltage range of the digital inputs is tied to the selected power supply. If a power supply version with the higher rated input voltage is selected, the feeder terminals will be delivered with digital inputs that also have the higher rated input voltage.

For further technical data of the power supply, refer to Table 5.2.1-2 on page 89.

5.1.5.2.

Low auxiliary voltage indication

The REF 54_ feeder terminal is provided with a low auxiliary voltage indication feature. The power supply module issues an internal alarm signal when a drop in the power supply voltage is detected (ACFail, active low). The alarm signal is activated if the power supply voltage falls about 10% below the lowest rated DC input voltage of the power supply module, see the following table.

Table 5.1.5.2-1 Low auxiliary voltage indication for power supplies

Rated input voltage	Low indication level
PS_/240	
• Rated input voltage 110/125/ 220 V DC	99 V DC
• Rated input voltage 110/120/220/ 240 V AC	88 V AC
PS_/48	
• Rated input voltage 24/48/60 V DC	21.6 V DC

The indication of a low auxiliary voltage (ACFail) is available in the feeder terminal configuration environment and can be connected to any signal output of the REF 54_. The auxiliary voltage indication in the feeder terminal configuration is as follows:

REF 541: PS1_4_ACFail

REF 543: PS1_4_ACFail

REF 545: PS2_4_ACFail

5.1.5.3.

Overtemperature indication

The REF 54_ feeder terminal includes an internal temperature supervision function. The power supply module issues an internal alarm signal when overtemperature has been detected inside the terminal enclosure. The alarm signal will be activated once the temperature inside the terminal enclosure increases to +78°C (+75...+83° C). Overtemperature indication is available in the feeder terminal configuration and can be connected to any signal output of the terminal. The overtemperature indication input in the feeder terminal configuration is as follows:

REF 541: PS1_4_TempAlarm

REF 543: PS1_4_TempAlarm

REF 545: PS2_4_TempAlarm

5.1.6. Analog channels

The feeder terminal measures the analog signals needed for protection, measuring, and so on via sensors or galvanically separated matching transformers. The REF 54_ feeder terminals are provided with the following matching transformers:

- 9 matching transformers: CT1, CT2, CT3, CT4, CT5, VT1, VT2, VT3, VT4

In addition to conventional matching transformers, current sensors and voltage dividers developed by ABB can be used in REF 54_ feeder terminals. The feeder terminal has 9 sensor inputs¹. A current sensor (Rogowski coil) or a voltage divider can be connected to each sensor input. The feeder terminal allows the user to configure each sensor input for the type of sensor to be used. Furthermore, the feeder terminal is provided with general measurement via sensor inputs. This allows for example temperature monitoring, provided a temperature sensor with a voltage transducer output is available.

The third letter in the four-letter extension of the order number specifies whether the feeder terminal is to be equipped with conventional matching transformers or with matching transformers and sensor inputs. (Refer to Section “Ordering Information” on page 103).

- REF541K_115AA_A /BA_A/CA_A /AA_B/BA_B
- REF541K_118AA_A /BA_A/CA_A /AA_B/BA_B
- REF543K_127AA_A/BA_A/CA_A/AA_B/BA_B
- REF543K_129AA_A /BA_A/CA_A /AA_B/BA_B
- REF545K_133AA_A/BA_A /CA_A /AA_B/BA_B

The matching transformers and sensor inputs of the feeder terminal are designed to allow either sensors or matching transformers to be used on the measuring channels 2...5 and 7...10. Should a matching transformer be used on a channel, no sensor is allowed to be used on the same channel or vice versa. On channel 1 only sensors can be used and on channel 6 only a matching transformer.

1. Feeder terminal revisions of releases prior to Release 2.0 are provided with 8 sensor channels.

Technical Reference Manual, General

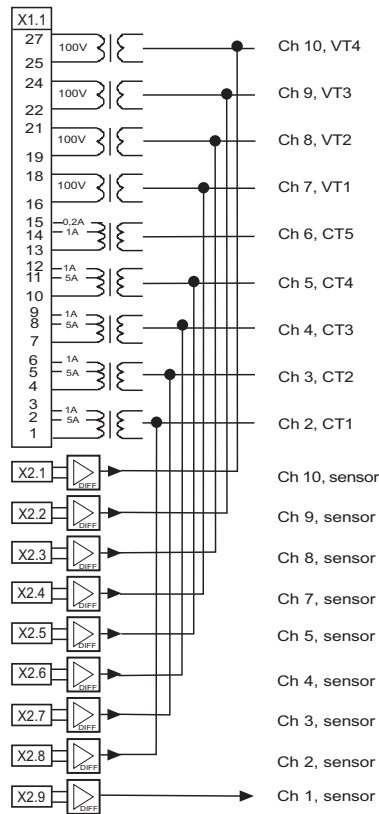

A050184

Fig. 5.1.6.-1 Analog channels with 9 matching transformers and 9 sensors

Depending on whether sensors are included or not, REF 54_ feeder terminals have 9 (without sensors) or 10 (with sensors) physical analog channels (see table below). The number of channels used depends on the feeder terminal configuration and the kind of matching transformers or sensor inputs used. Furthermore, the feeder terminal includes virtual analog channels (refer to Section “Calculated analog channels” on page 42) for calculating the neutral current, phase-to-phase voltage and residual voltage from phase currents and voltages.

Each analog channel is separately configured with the Relay Configuration Tool. Both the measuring unit for each analog channel and the type of signal to be measured are to be configured.

Table 5.1.6-1 Physical analog channels of the feeder terminals

Ch No.	Measuring units					
	Current Transformer (CT)	Voltage Transformer (VT)	Rogovski coil/-sensor (RS)	Voltage divider (VD)	General measurement	Signal type (selectable alternatives)
1			RS 1...10	VD 1...10	Gen. meas. 1...3	Not in use, I _{L1} , I _{L2} , I _{L3} , I _{L1b} , I _{L2b} , I _{L3b} , U ₁ , U ₂ , U ₃ , U _{1b} , U _{2b} , U _{3b} , U _{1c} , GE1, GE2, GE3
2	Current Transformer CT1 (I _n = 1 A/5 A)		RS 1...10	VD 1...10	Gen. meas. 1...3	Not in use, I _{L1} , I _{L2} , I _{L3} , I _{L1b} , I _{L2b} , I _{L3b} , I ₀ , I _{0b} , U ₁ , U ₂ , U ₃ , U _{1b} , U _{2b} , U _{3b} , U _{1c} , GE1, GE2, GE3
3	Current Transformer CT2 (I _n = 1 A/5 A)					
4	Current Transformer CT3 (I _n = 1 A/5 A)					
5	Current Transformer CT4 (I _n = 1 A/5 A)					
6	Current Transformer CT5 (I _n = 0.2 A/1 A)					
7		Voltage Transformer VT1 (U _n =100V/110V/115V/120V)	RS 1...10	VD 1...10	Gen. meas. 1...3	Not in use, I _{L1} , I _{L2} , I _{L3} , I _{L1b} , I _{L2b} , I _{L3b} , U ₁₂ , U ₂₃ , U ₃₁ , U _{12b} , U _{23b} , U _{31b} , U _{12c} , U ₁ , U ₂ , U ₃ , U _{1b} , U _{2b} , U _{3b} , U _{1c} , U ₀ , U _{0b} , GE1, GE2, GE3
8		Voltage Transformer VT2 (U _n =100V/110V/115V/120V)				
9		Voltage Transformer VT3 (U _n =100V/110V/115V/120V)				
10		Voltage Transformer VT4 (U _n =100V/110V/115V/120V)				

The letters b and c after the signal type are used to distinguish between signals of the same type.

5.1.6.1.

Scaling the rated values of the protected unit for analog channels

A separate scaling factor can be set for each analog channel. The factors enable differences between the ratings of the protected unit and those of the measuring device (CTs, VTs and so on) The setting value 1.000¹ means that the rated value of the protected unit is exactly the same as that of the measuring device.

When scaling factors are used, it should be noted that they affect the operation accuracy and the dynamic measuring range of the terminal. The accuracies stated in the description of each function block (see the CD-ROM “Technical Descriptions of Functions”) only apply with the default values of the scaling factors. For example, a high factor affects the operation of sensitive protection functions, such as the directional earth-fault protection.

1. Prior to Release 2.5 with two decimals only.

Technical Reference Manual, General

The scaling factor is calculated channel by channel as follows:

Scaling factor = I_{nmd} / I_{np} , where

I_{nmd}	Rated primary current of the measuring device (A)
I_{np}	Rated primary current of the protected unit connected to the channel

Example:

Rated primary current of current trafo = 500 A:	$I_{nmd} = 500 \text{ A}$
Rated current of the protected unit = 250 A:	$I_{np} = 250 \text{ A}$
Scaling factor for current channels:	$500 \text{ A} / 250 \text{ A} = 2.000^1$



The scaling factor is not used for general measurement signals connected to the analog channel.

The scaling factors for the analog channels can be set via the HMI of the feeder terminal or with the Relay Setting Tool. The HMI path for the scaling factors is: Main Menu/ Configuration/ Protected unit/ Ch 1: scaling, Ch 2: scaling...

For storing the values listed above, refer to Section “Storing of parameters and recorded data” on page 33.

5.1.6.2.

Technical data of the measuring devices

When the feeder terminal is configured, the technical data of the measuring devices is set in separate dialog boxes in the Relay Configuration Tool. The set values will affect the measurements carried out by the feeder terminal.

For storing the values listed below, refer to Section “Storing of parameters and recorded data” on page 33.

Values to be set for a current transformer:

- Rated primary current ($1...6000 \text{ A}$)¹ of the primary current transformer.
- Rated secondary current (5 A, 2 A, 1 A, 0.2 A) of the primary current transformer.
- Rated current (5 A, 1 A, 0.2 A) of the current measuring input (= rated current of the matching transformer of the feeder terminal).
- Amplitude correction factor (0.9000...1.1000) of the primary current transformer at rated current.
- Correction parameter for the phase displacement error of the primary current transformer at rated current ($-5.00^\circ...0.00^\circ$).
- Amplitude correction factor of the primary current transformer at a signal level of 1% of the rated current (0.9000...1.1000).
- Correction parameter for the phase displacement error of the primary current transformer at a signal level of 1% of the rated current ($-10.00^\circ...0.00^\circ$).

1. Prior to Release 2.5, the current range is 0...6000 A.

Values to be set for a voltage transformer:

- Rated voltage of voltage input (same as the secondary rated voltage of the primary voltage transformer connected to the voltage input, 100 V, 110 V, 115 V, 120 V).
- Rated voltage of primary voltage transformer (0.100...440.000 kV)¹.
- Amplitude correction factor of the primary voltage transformer voltage at rated voltage (0.9000...1.1000).
- Correction parameter for the primary transformer phase displacement error at rated voltage (-2.00°... 2.00°).

Values to be set for a current sensor (Rogowski coil):

- Secondary rated voltage of the current sensor used at the preset primary rated current (100...300 mV)².
- Primary rated current of the current sensor used (1...6000 A)³.
- Amplitude correction factor of the current sensor used at rated current (0.9000...1.1000).
- Correction parameter for the phase displacement error of the current sensor (-1.0000°...1.0000°)⁴.

Values to be set for a voltage divider:

- Division ratio of the voltage divider primary and secondary voltage (1...20000)⁵.
- Rated value of primary phase-to-phase voltage (0.100...440.000 kV)¹.
- Amplitude correction factor of the voltage divider (0.9000...1.1000).
- Correction parameter for the phase displacement error of the voltage divider (-1.0000°...1.0000°)⁴.

Values to be set for general measurement:⁶

- Amplitude correction factor of general measurement (-10000.00000...10000.00000).
- Correction parameter for the offset correction of general measurement (-10000.00000...10000.00000).

-
1. For Release 1.0, the voltage range is 0...150 kV. For Release 1.5 and Release 2.0, the range is 0...300 kV.
 2. Prior to Release 2.5, the voltage range is 0...300 mV.
 3. Prior to Release 2.5, the current range is 0...6000 A.
 4. Only included in the feeder terminal revisions of Release 2.0 or later, refer to Section "Revision identification" on page 105. Note that this parameter can only be set via the HMI or the Relay Setting Tool.
 5. Prior to Release 2.5, the division ratio is 0...20000.
 6. Only included in the feeder terminal revisions of Release 2.0 or later.

Technical Reference Manual, General

The measurement values stated by the manufacturer of the measuring device are used for calculating the correction parameters and factors according to the following formulas:

Current transformers

Amplitude error at current I_n (e = error in per cent)	Amplitude correction factor 1 $= 1 / (1 + e/100)$
Amplitude error at current $0.01 \times I_n$ (e = error in per cent)	Amplitude correction factor 2 $= 1 / (1 + e/100)$
Phase displacement error at current I_n (e = error in degrees)	Phase displacement error 1 = - e
Phase displacement error at current $0.01 \times I_n$ (e = error in degrees)	Phase displacement error 2 = - e

Voltage transformers

Amplitude error at voltage U_n (e = error in per cent)	Amplitude correction factor $= 1 / (1 + e/100)$
Phase displacement error at voltage U_n (e = error in degrees)	Phase displacement error = - e

Rogowski coil

Amplitude error at the whole measuring range (e = error in per cent)	Amplitude correction factor $= 1 / (1 + e/100)$
Phase displacement error at the whole measuring range (e = error in degrees)	Phase displacement error = - e

Voltage divider

Amplitude error at the whole measuring range (e = error in per cent)	Amplitude correction factor $= 1 / (1 + e/100)$
Phase displacement error at the whole measuring range (e = error in degrees)	Phase displacement error = - e

5.1.6.3. Calculated analog channels

The REF 54_ feeder terminal includes virtual channels to obtain phase-to-phase voltages, residual voltage and neutral current when sensors are used. Current sensors and voltage dividers are connected to the feeder terminal via coaxial cables. Therefore a phase-to-phase voltage connection, an open-delta connection of phase voltages or a residual connection of phase currents cannot be made. Both the amplitude and the phase angle are calculated for the virtual channels.

The virtual channel voltages and currents are numerically derived from the phase voltages and phase currents according to Table . Though primarily meant to be used with sensors, the calculated analog channels can also be used with conventional current and voltage transformers.

The virtual channels will be numbered according to the priority numbers in Table . The virtual channels used first will be numbered as 11 and the following as 12, 13 and so on. For example, U_{0s} is numbered as 11 and U_{12s} as 12, if these virtual channels are selected for use.



When sensitive earth-fault protection is needed, core balance transformers are not recommended to be replaced with the numerically derived sum of phase currents. Normally, an earth-fault setting below 10% of the rated value requires the use of a core balance transformer.

Table 5.1.6.3-1 Virtual analog channels

Virtual channel	Numeric derivation	Priority number
I_{0s}	$= -(I_{L1} + I_{L2} + I_{L3})^{1)}$	1
$I_{0bs}^{2)}$	$= -(I_{L1b} + I_{L2b} + I_{L3b})^{1)}$	2
U_{0s}	$= (U_1 + U_2 + U_3)/3$	3
$U_{0bs}^{2)}$	$= (U_{1b} + U_{2b} + U_{3b})/3$	4
$U_{12s}^{2)}$	$= (U_1 - U_2)$	5
$U_{23s}^{2)}$	$= (U_2 - U_3)$	6
$U_{31s}^{2)}$	$= (U_3 - U_1)$	7
$U_{12bs}^{2)}$	$= (U_{1b} - U_{2b})$	8
$U_{23bs}^{2)}$	$= (U_{2b} - U_{3b})$	9
$U_{31bs}^{2)}$	$= (U_{3b} - U_{1b})$	10

- 1) A minus in front of the parenthesis means, that the default direction of neutral current is assumed to be from the line to the busbar, while the normal power flow is from the busbar to the line.
- 2) This virtual channel is supported in the feeder terminal revisions of Release 2.5 or later, refer to the section "Revision identification" on page 105.

5.1.7.**Digital inputs**

The REF 541, REF 543 and REF 545 feeder terminals differ from each other regarding the number of digital inputs available.

The digital inputs of the REF 54_ feeder terminals are voltage-controlled and optically isolated. For technical data of the digital inputs, refer to Table 5.2.1-3 on page 89.

The parameters for input filtering, input inversion and pulse counters (see sections below) can be set in the Configuration menu under each I/O card (for example Configuration/BIO1/Input filtering).

The events and parameters of I/O cards are included in the event and parameter lists on the CD-ROM “Technical Descriptions of Functions” (refer to Section “Related documents” on page 10).

Table 5.1.7-1 Digital inputs available for the REF 54_

	REF 541	REF 543	REF 545
Inputs	PS1_4_BI1 ¹⁾	PS1_4_BI1 ¹⁾	BIO1_5_BI1
	PS1_4_BI2 ¹⁾	PS1_4_BI2 ¹⁾	BIO1_5_BI2
	PS1_4_BI3 ¹⁾	PS1_4_BI3 ¹⁾	BIO1_5_BI3
	BIO1_5_BI1	BIO1_5_BI1 BIO1_5_	BI4
	BIO1_5_BI2	BIO1_5_BI2 BIO1_5_	BI5
	BIO1_5_BI3	BIO1_5_BI3 BIO1_5_	BI6
	BIO1_5_BI4	BIO1_5_BI4	BIO1_5_BI7
	BIO1_5_BI5	BIO1_5_BI5 BIO1_5_	BI8
	BIO1_5_BI6	BIO1_5_BI6	BIO1_5_BI9 ¹⁾
	BIO1_5_BI7	BIO1_5_BI7	BIO1_5_BI10 ¹⁾
	BIO1_5_BI8	BIO1_5_BI8	BIO1_5_BI11 ¹⁾
	BIO1_5_BI9 ¹⁾	BIO1_5_BI9 ¹⁾	BIO1_5_BI12 ¹⁾
	BIO1_5_BI10 ¹⁾	BIO1_5_BI10 ¹⁾	BIO1_6_BI1
	BIO1_5_BI11 ¹⁾	BIO1_5_BI11 ¹⁾	BIO1_6_BI2
	BIO1_5_BI12 ¹⁾	BIO1_5_BI12 ¹⁾	BIO1_6_BI3
		BIO2_7_BI1 BIO1_6_	BI4
		BIO2_7_BI2	BIO1_6_BI5
		BIO2_7_BI3	BIO1_6_BI6
		BIO2_7_BI4 BIO1_6_	BI7
		BIO2_7_BI5	BIO1_6_BI8
		BIO2_7_BI6	BIO1_6_BI9 ¹⁾
		BIO2_7_BI7	BIO1_6_BI10 ¹⁾
		BIO2_7_BI8	BIO1_6_BI11 ¹⁾
		BIO2_7_BI9 ¹⁾	BIO1_6_BI12 ¹⁾
		BIO2_7_BI10 ¹⁾	BIO2_7_BI1
			BIO2_7_BI2
			BIO2_7_BI3
			BIO2_7_BI4
			BIO2_7_BI5
			BIO2_7_BI6

Table 5.1.7-1 Digital inputs available for the REF 54_ (Continued)

	REF 541	REF 543	REF 545
			BIO2_7_BI7
			BIO2_7_BI8
			BIO2_7_BI9 ¹⁾
			BIO2_7_BI10 ¹⁾
Digital inputs / total	15	25	34

1) These digital inputs can be programmed as either digital inputs or pulse counters, refer to Section "Pulse counters" on page 45.

5.1.7.1.

Filter time of a digital input

The filter time eliminates debounces and short disturbances on a digital input. The filter time is set for each digital input of the REF 54_ feeder terminal. The operation of input filtering is illustrated below.

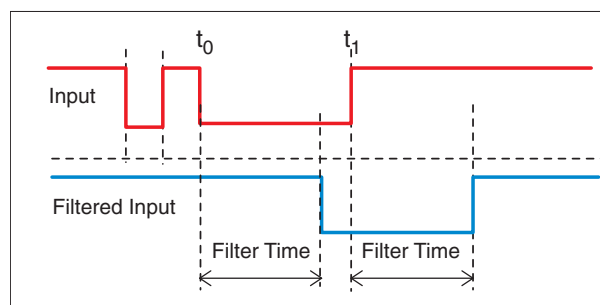

dipo_b

Fig. 5.1.7.1.-1 Filtering of a digital input

In the figure above, the input signal is named 'Input', the filter timer 'Filter Time' and the filtered input signal 'Filtered Input'. At the beginning, the input signal is at high state, the short low state is filtered and no input state change is detected. The low state starting from the time t_0 exceeds the filter time, which means that the change in the input state is detected and the time tag attached to the input change is t_0 . The high state starting from t_1 is detected and the time tag t_1 is attached.

Each digital input has a filter time parameter "Input # filter", where # is the number of the digital input of the module in question (for example Input 1 filter).

Parameter	Values	Default
Input # filter	1....15000 ms ¹⁾	5 ms

¹⁾ In the feeder terminal revisions of Release 2.5 or later. Before Release 2.5: 1...65535 ms.

5.1.7.2. Inversion of a digital input

The parameter “Input # invert” can be used to invert a digital input:

Control voltage	Input # invert	State of digital input
No	0	FALSE (0)
Yes	0	TRUE (1)
No	1	TRUE (1)
Yes	1	FALSE (0)

When the digital input is inverted, the state of the input is TRUE (1) when no control voltage is applied to its terminals. Accordingly, the input state is FALSE (0) when a control voltage is applied to the terminals of the digital input.

Parameter	Values	Default
Input # invert	0 (not inverted)	0
	1 (inverted)	

5.1.7.3. Pulse counters

Some specific digital inputs (refer to Section “Digital inputs” on page 43) of the REF 54_ feeder terminal can be programmed either as digital inputs or as pulse counters. This programming is done via the parameter “Input # mode” (in this parameter as well as in others mentioned below, # denotes the input number).

When an input operates as a pulse counter, the positive input transitions (0 -> 1) of a filtered input are counted and the counter value of “Input # counter” increases in the range 0... 2147483647. The pulse counters are updated with a period of 500 ms. The frequency range of a digital input parameterized to operate as a pulse counter is 0...100 Hz.

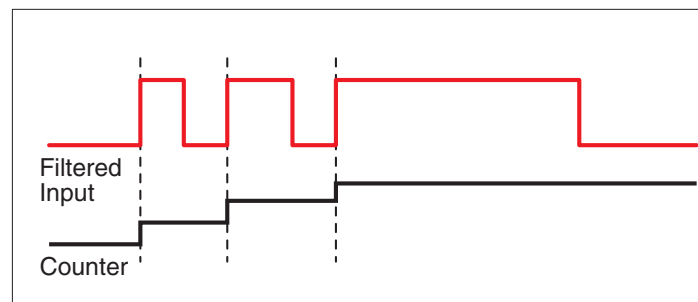

dipo2_b

Fig. 5.1.7.3.-1 Principle of pulse counter function

The parameter “Input # preset” can be used to give a counter the start value. The start value is loaded into the counter by:

- Writing the desired start value to the parameter “Input # preset”.
- Writing the value 1 to the parameter “Counter trigger”. Then all the updated values of the “Input # preset” parameters are copied to the corresponding “Input # counter” parameters.

Writing the value 2 to the “Counter trigger” parameter copies all the “Input # preset” values to the corresponding “Input # counter” parameters. Writing the value 0 clears all the counters.

Parameter	Values	Default
Input # preset	0..... 2147483647	0
Input # mode	1 = digital input 2 = counter	1
Counter trigger	0 = clear all counters 1 = load updated Input # preset values 2 = load all Input # preset values	

5.1.7.4.

Oscillation suppression

Oscillation suppression is used to reduce the load from the system when, for some unrecognized reason, a digital input starts oscillating. A digital input is regarded as oscillating if the number of valid state changes (= number of events after filtering) during 1 second is equal to or greater than¹ the set value “Input osc. level” (Oscillation level). During oscillation, the digital input is blocked (the status is invalid) and an event is generated. The state of the input will not change when it is blocked, that is, its state depends on the condition before blocking.

The digital input is regarded as non-oscillating if the number of valid state changes during 1 second is less than the set value of “Input osc. level” minus the set value of “Input osc. hyst.” (Oscillation hysteresis). Note that the oscillation hysteresis must be set lower than the oscillation level to enable the input to be restored from oscillation. When the input returns to a non-oscillating state, the digital input is deblocked (the status is valid) and an event is generated.

Parameter	Values	Default
Input osc. level	2...50 events/s	50 events/s
Input osc. hyst.	2...50 events/s	10 events/s



Unlike most parameters for digital I/O cards, the parameters “Input osc. level” and “Input osc. hyst.” can be found in the menu Configuration/General.

1. Before Release 2.5 only greater than.

5.1.7.5.**Attributes of a digital input for feeder terminal configuration**

The validity of the digital input (invalidity), the state of the input (value), the time tag for the state change (time) and the counter value of the input can be issued for each digital input by the attributes BI#IV, BI#, BI#Time and BI#Count, where # denotes the number of the input. These attributes are available in the feeder terminal configuration and can be used for different purposes.

The example below shows how the attributes of the digital input 1 (PS1_4_BI1 on PS1 module) of the feeder terminal REF 541 are named for the configuration:

PS1_4_BI1IV; digital input invalidity

PS1_4_BI1; digital input value

PS1_4_BI1Time; time tag

PS1_4_BT1Count; counter value

Invalidity (BI#IV)

When a digital input oscillates, the invalidity attribute IV changes to TRUE (1) and the input is blocked. The digital input is regarded as being blocked and oscillating if the number of state changes per second exceeds the set “Input osc. level” value (events/s).

When a digital input does not oscillate, the invalidity attribute IV changes to FALSE (0) and the input becomes operative. The digital input is regarded as being operative and non-oscillating if the number of state changes per second is less than the set “Input osc. level” value minus the set “Input osc. hyst.” value (events/s).

If the digital input is used in counter mode, IV is always TRUE (1).

Value (BI#)

Depending on the state of the digital input, the digital input value is TRUE (1) or FALSE (0). The BI# value changes on the rising or falling edge of the input. To prevent undesired state changes of the digital input due to for example switch debouncing, the change of the attribute value is delayed by the filter time.

The value attribute of the digital input is not updated when the input is programmed as counter digital input.

Time (BI#Time)

Each change (rising or falling edge) detected in the state of a digital input is time-tagged at an accuracy of ± 1 ms. The time tag represents the moment (time) of the latest input change of the value attribute. The time is not recorded until the filtering time of the state change has elapsed, which means that the filtering time does not affect the time tag value.

Count (BI#Count)

The count attribute indicates the number of positive input transitions of a filtered input. Refer to section “Pulse counters” on page 45.

The counter attribute of a digital input is not updated when the input is programmed as a normal digital input.

5.1.8. Digital outputs

The outputs of the REF 54_ feeder terminal are categorized as follows:

HSPO	High-speed power output, double-pole contact, preferred for tripping purposes and for circuit breaker and disconnect control
PO	Power output, either single-pole or double-pole contact, preferred for circuit breaker and disconnect control
SO	Signal output, either NO (Normally Open) or NO/NC (Normally Open/ Normally Closed) contact

The events and parameters of I/O cards are included in the event and parameter lists on the CD-ROM “Technical Descriptions of Functions” (refer to Section “Related documents” on page 10).

For information about terminal connections for the outputs, refer to terminal diagrams (beginning on page 94), where all the outputs are included with relay connector terminals.

For technical data of the outputs, see Table 5.2.1-6 on page 90.

Table 5.1.8-1 Digital outputs

	REF 541	REF 543	REF 545
Outputs	PS1_4_HSPO1 ¹⁾	PS1_4_HSPO1 ¹⁾	PS2_4_HSPO1 ¹⁾
	PS1_4_HSPO2 ¹⁾	PS1_4_HSPO2 ¹⁾	PS2_4_HSPO2 ¹⁾
	PS1_4_HSPO3 PS1_4_HSPO3	PS1_4_HSPO3	PS2_4_HSPO3
	PS1_4_HSPO4	PS1_4_HSPO4	PS2_4_HSPO4
	PS1_4_HSPO5	PS1_4_HSPO5	PS2_4_HSPO5
	PS1_4_SO1 PS1_4_SO1	PS1_4_SO1	PS2_4_HSPO6
	BIO1_5_SO1	BIO1_5_SO1	PS2_4_HSPO7
	BIO1_5_SO2	BIO1_5_SO2	PS2_1_HSPO8
	BIO1_5_SO3	BIO1_5_SO3	BIO1_5_SO1
	BIO1_5_SO4	BIO1_5_SO4	BIO1_5_SO2
	BIO1_5_SO5	BIO1_5_SO5	BIO1_5_SO3
	BIO1_5_SO6	BIO1_5_SO6	BIO1_5_SO4
		BIO2_7_PO1	BIO1_5_SO5
		BIO2_7_PO2	BIO1_5_SO6
		BIO2_7_PO3	BIO1_6_SO1
		BIO2_7_PO4	BIO1_6_SO2
		BIO2_7_PO5	BIO1_6_SO3
		BIO2_7_PO6	BIO1_6_SO4
			BIO1_6_SO5
			BIO1_6_SO6
			BIO2_7_PO1
			BIO2_7_PO2
			BIO2_7_PO3
			BIO2_7_PO4
			BIO2_7_PO5
			BIO2_7_PO6
Outputs / total	12	18	26

¹⁾ Trip Circuit Supervision function included

5.1.8.1.

High-speed double-pole power outputs (HSPO)

The high-speed power outputs PS1_4_HSPO1... PS1_4_HSPO5 and PS2_4_HSPO1...PS2_4_HSPO7 can be connected as double-pole outputs where the object to be controlled, for example a circuit breaker, is electrically connected between the two relay contacts, see the § below. The high-speed double-pole power output is recommended to be used for tripping purposes.



When TCS is used (see Table 5.1.8-1 on page 48), the outputs are connected as shown in Fig. 5.1.11.-1 and Fig. 5.1.11.-1 on page 64.

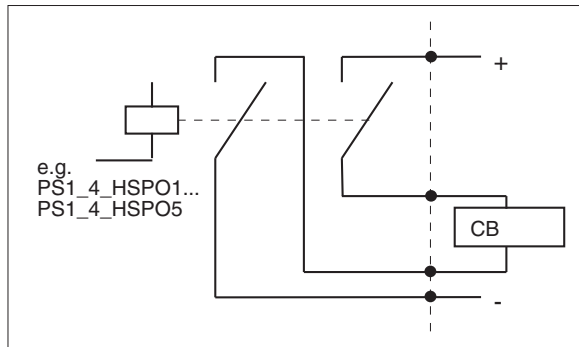

cbcoil_b

Fig. 5.1.8.1.-1 High-speed double-pole power outputs (HSPO)

The high-speed power outputs PS1_4_HSPO1... PS1_4_HSPO5 and PS2_4_HSPO1...PS2_4_HSPO7 can also be connected as single-pole power outputs where the object to be controlled, for example a circuit breaker, is electrically connected in series with the two relay contacts, see the figure below.

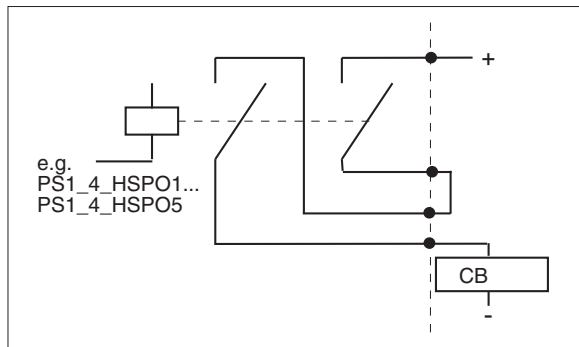

doubpole_b

Fig. 5.1.8.1.-2 High-speed single-pole power outputs (HSPO)

5.1.8.2.**Single-pole power outputs (PO) and a high-speed single-pole power output (HSPO)**

The single-pole power outputs BIO2_7_PO1 and BIO2_7_PO2 as well as the high-speed single-pole power output PS2_4_HSPO8 are outputs where the object to be controlled is connected in series with two heavy-duty output relay contacts, see the following figure. These outputs can be used for tripping purposes and for circuit breaker and disconnector control.

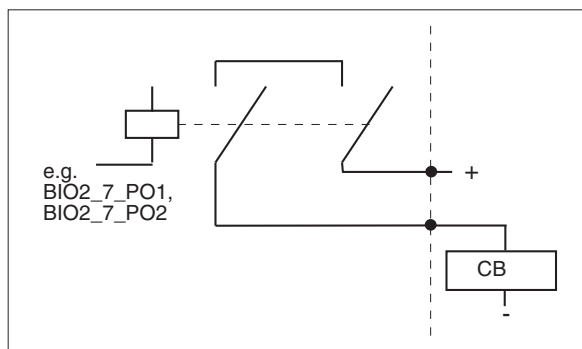

PO1conn_b

Fig. 5.1.8.2.-1 Single-pole power outputs BIO2_7_PO1 and BIO2_7_PO2, and the high-speed single-pole power output PS2_4_HSPO8

5.1.8.3.**Double-pole power outputs (PO)**

The double-pole power outputs BIO2_7_PO3... BIO2_7_PO6 are outputs where the object to be controlled, for example a circuit breaker, is electrically connected between the two relay contacts, see the following figure. These outputs can be used for tripping purposes and for circuit breaker and disconnector control.

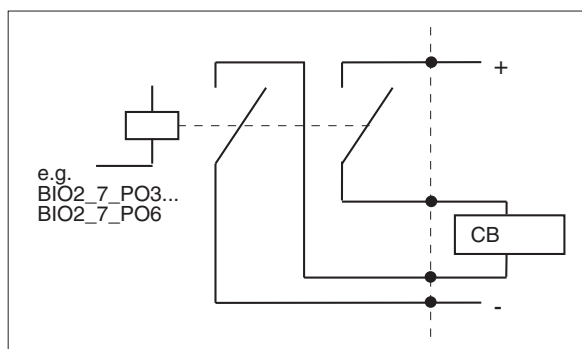

PO3conn_b

Fig. 5.1.8.3.-1 Double-pole power outputs (PO)

If the power outputs BIO2_7_PO3... BIO2_7_PO6 are used as single-pole outputs, the object to be controlled, for example a circuit breaker, is electrically connected in series with the two relay contacts to provide sufficient current breaking capacity, see the following figure.

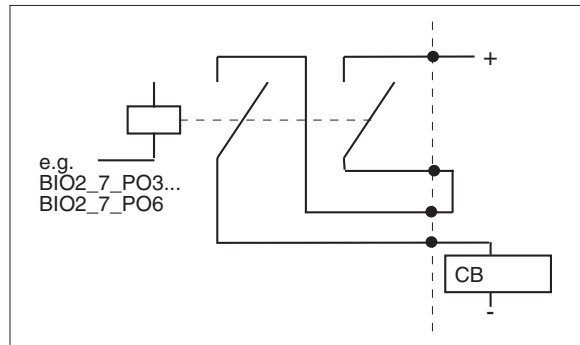

PO2conn_n

Fig. 5.1.8.3.-2 Single-pole power outputs (PO)

5.1.8.4.

Signal outputs (SO)

The signalling relay outputs (BIO1_5_SO_) are not heavy-duty outputs and thus they cannot be used for controlling for example a circuit breaker. Available relay contacts are either Normally Open or Normally Open/Normally Closed type (NO or NO/NC), see the following figure. These outputs can be used for alarming and other signalling purposes.

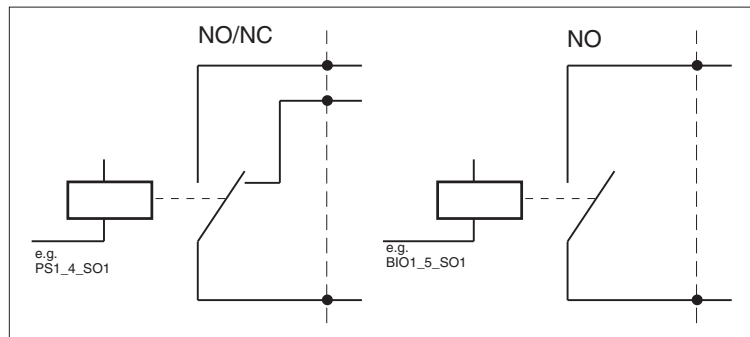

nonc_b

Fig. 5.1.8.4.-1 Signal outputs (SO)

5.1.9.

RTD/analog inputs

The REF 541 and REF 543 feeder terminals equipped with an RTD/analog module (RTD1) have eight general purpose analog inputs for DC measurement. The RTD/analog inputs are galvanically isolated from the feeder terminal power supply and enclosure. However, the inputs share a common ground.

For technical data of the RTD/analog inputs, refer to Table 5.2.1-4 on page 90.

	REF 541/REF 543 + RTD1
RTD/analog inputs	RTD1_6_AI1
	RTD1_6_AI2
	RTD1_6_AI3
	RTD1_6_AI4
	RTD1_6_AI5
	RTD1_6_AI6
	RTD1_6_AI7
	RTD1_6_AI8

The parameters for the RTD/analog inputs are included in the parameter lists on the CD-ROM “Technical Descriptions of Functions” (refer to Section “Related documents” on page 10).

5.1.9.1.

Selection of input signal type

The general purpose RTD/analog inputs accept voltage-, current- or resistance-type signals. The inputs are configured for a particular type of input signal by means of the channel-specific “Input mode” parameters that can be found in the menu Configuration/RTD1/Input #. The default value is “Off” which means that the channel is not sampled at all, and the IN+, IN- and SHUNT terminals are at high impedance state.

Parameter	Values	Default
Input mode	0 = Off	Off
	1 = Voltage	
	2 = Current	
	3 = Resistance 2W ¹⁾	
	4 = Resistance 3W ²⁾	
	5 = Temperature 2W ¹⁾	
	6 = Temperature 3W ²⁾	

1) Two-wire measurement

2) Three-wire measurement

5.1.9.2.

Selection of input signal range

For each measuring mode, a separate parameter is provided for choosing between the available measurement ranges. These channel-specific parameters, which can be found in the menu Configuration/RTD1/Input #, are named “Voltage range”, “Current range”, “Resistance range” and “Temperature range”. All range parameters can be set but only one is used. The value of the “Input mode” parameter determines which range parameter is used. The “Temperature range” parameter also defines the sensor type to be used, for example PT100.

Technical Reference Manual, General

Table 5.1.9.2-1 Measurement ranges

Parameter	Values	Default
Voltage range	0 = 0...1V	0...1 V
	1 = 0...5 V	
	2 = 1...5 V	
	3 = 0...10 V	
	4 = 2...10 V	
	5 = -5...5 V	
	6 = -10...10 V	
Current range	0 = 0...1 mA	0...1 mA
	1 = 0...5 mA	
	2 = 1...5 mA	
	3 = 0...10 mA	
	4 = 0...20 mA	
	5 = 4...20 mA	
	6 = -1...1 mA	
	7 = -2.5...2.5 mA	
	8 = -5...5 mA	
	9 = -10...10 mA	
	10 = -20...20 mA	
Resistance range	0 = 0...100 Ω	0...100 Ω
	1 = 0...200 Ω	
	2 = 0...500 Ω	
	3 = 0...1000 Ω	
	4 = 0...2000 Ω	
	5 = 0...5000 Ω	
	6 = 0...10000 Ω	
Temperature range	0 = Pt100 -45...150 $^{\circ}\text{C}$	Pt100 -45...150 $^{\circ}\text{C}$
	1 = Pt100 -45...600 $^{\circ}\text{C}$	
	2 = Pt250 -45...150 $^{\circ}\text{C}$	
	3 = Pt250 -45...600 $^{\circ}\text{C}$	
	4 = Pt1000 -45...150 $^{\circ}\text{C}$	
	5 = Pt1000 -45...600 $^{\circ}\text{C}$	
	6 = Ni100 -45...150 $^{\circ}\text{C}$	
	7 = Ni100 -45...250 $^{\circ}\text{C}$	
	8 = Ni120 -45...150 $^{\circ}\text{C}$	
	9 = Ni120 -45...250 $^{\circ}\text{C}$	
	10 = Ni250 -45...150 $^{\circ}\text{C}$	
	11 = Ni250 -45...250 $^{\circ}\text{C}$	
	12 = Ni1000 -45...150 $^{\circ}\text{C}$	
	13 = Ni1000 -45...250 $^{\circ}\text{C}$	
	14 = Cu10 -45...150 $^{\circ}\text{C}$	
	15 = Ni120US -45...150 $^{\circ}\text{C}$ ¹⁾	
16 = Ni120US -45...250 $^{\circ}\text{C}$ ¹⁾		

1) These ranges are supported only in the feeder terminal revisions of Release 2.5 or later.

5.1.9.3. Transducer supervision

The measuring signal level of each transducer is constantly supervised. If the measured signal falls more than 4% below or rises more than 4% over the specified input signal range of a particular channel, the transducer or the transducer wiring is considered to be faulty and the channel-specific invalid signal is immediately activated. The invalid signal is deactivated as soon as the transducer signal is within the valid range.

When necessary, the valid measuring range may be narrower than the default -4...104% of the selected measuring range. A narrower range can be defined by means of the parameters “Input high limit” and “Input low limit” that can be found in the menu `Configuration/RTD1/Input #`.

Parameter	Values	Default
Input low limit	-4...104%	-4%
Input high limit	-4...104%	104%

When an input is configured for resistance or temperature measurement, the internal excitation current generator forces a current pulse through the measuring circuit when the input is sampled. If the actual current level does not match the programmed level due to too high impedance in the circuit, the invalid signal is immediately activated. The invalid signal is deactivated as soon as the circuit resistance is low enough.

5.1.9.4. Signal filtering

Short disturbances on an input are eliminated by signal filtering. The filter time, which defines the step response time, is set for each transducer input of the feeder terminal by the “Filter time” parameters in the menu `Configuration/RTD1/Input #`. The filtering algorithm is a so-called median filter which shows no reaction to interference spikes but levels out directly on permanent changes.

Parameter	Values	Default
Filter time	0 = 0.4 s 1 = 1 s 2 = 2 s 3 = 3 s 4 = 4 s 5 = 5 s	5 s

5.1.9.5. Input scaling/linearization ¹

The user can scale each RTD/analog input linearly or non-linearly by constructing a separate linearization curve for each input. The name implies the typical use, that is, the linearization of not directly supported non-linear sensors. The curve consists of at least two points (for linear scaling) and up to ten points, where the x-axis of the curve is 0 to 1000 per mille of the range selected for the input, and the y-axis is the scaled absolute value of the input. The linearization curves can be enabled and disabled with the `Linear.curve` parameter in the menu `Configuration/RTD1/Input #`.

Parameter	Values	Default
Linear.curve	0=Disabled 1=Enabled	Disabled

The curve is constructed for the transformer terminal by using the Transducer Linearization Tool (TLT) in the CAP 505 relay tool package.

When the linearization curve is enabled, the `Input high limit` and `Input low limit` parameters define the scaled range instead of the range selected by the original range parameters. The range of the scaled input is defined as the range between the smallest y-axis value and the largest y-axis value.

5.1.9.6. Transducer connections

The RTD/analog inputs may be connected to a large variety of different measuring transducer types, both standardized and customer-specified types.

Three connection screws have been reserved for each channel. Further, one connection screw (analog ground) has been reserved per every two channels.

Two earth terminals (see Fig. 5.1.9.6.-1), located to the left of the connectors, are reserved for connecting the protective sheaths of the transducer input cables. The cable sheath is generally earthed in one end of the cable only.

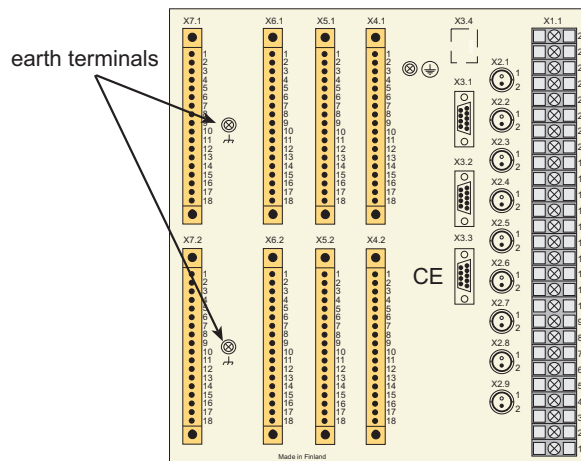
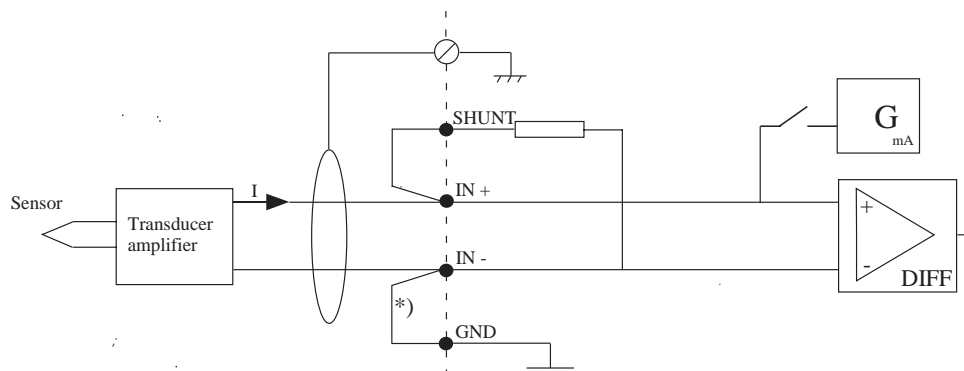

Fig. 5.1.9.6.-1 Earth terminals

1. This feature is supported in feeder terminal revisions of Release 3.0 or later.

Current transducers

When a current transducer is connected to the RTD/analog input, the SHUNT and IN+ terminals are linked together as are the GND and IN- terminals. The incoming current signal is connected to the IN+ terminal and the outgoing current signal to the IN- terminal.



curtran_b

Fig. 5.1.9.6.-2 Principle diagram for the connection of current transducers

Voltage transducers

When a voltage transducer is connected to the RTD/analog input, the GND and IN- terminals are linked together. The incoming voltage signal is connected to the IN+ terminal and the return voltage signal lead to the IN- terminal.

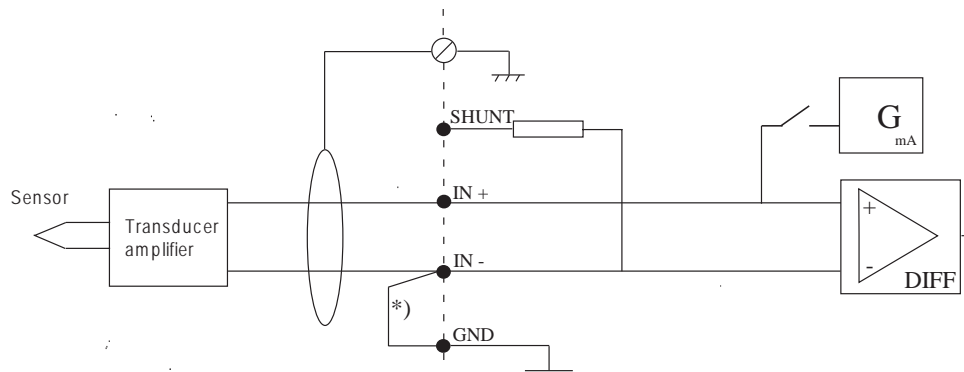

voltran_b

Fig. 5.1.9.6.-3 Principle diagram for the connection of voltage transducers

*) The GND terminals are galvanically isolated from the supply and enclosure of the feeder terminal, but they are all connected to each other, that is, they share the same potential. When several inputs are connected to single-ended signal sources that share a common ground, ground loops result if the connection GND <-> IN- is done on every input. In this situation, the connection GND <-> IN- is done on only one of the concerned RTD/analog inputs.

Resistance sensors

The resistance sensors may be connected to the RTD/analog input according to either the three-wire or the two-wire connection principle. With the three-wire measuring principle, the wire resistance is automatically compensated. The resistor, or RTD sensor, is connected across the IN+ and IN- inputs, and the - side of the resistor/RTD sensor is connected to the GND input. The leads connected to the IN+ and GND inputs must be of the same type.

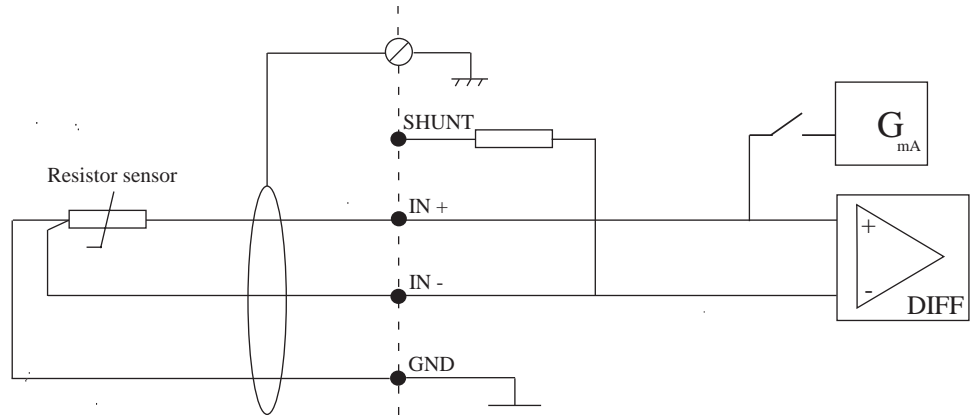

resist3w_b

Fig. 5.1.9.6.-4 Principle diagram of the three-wire connection

With the two-wire principle, the IN- and GND terminals are linked together. The resistor is connected across the IN+ and IN- inputs.

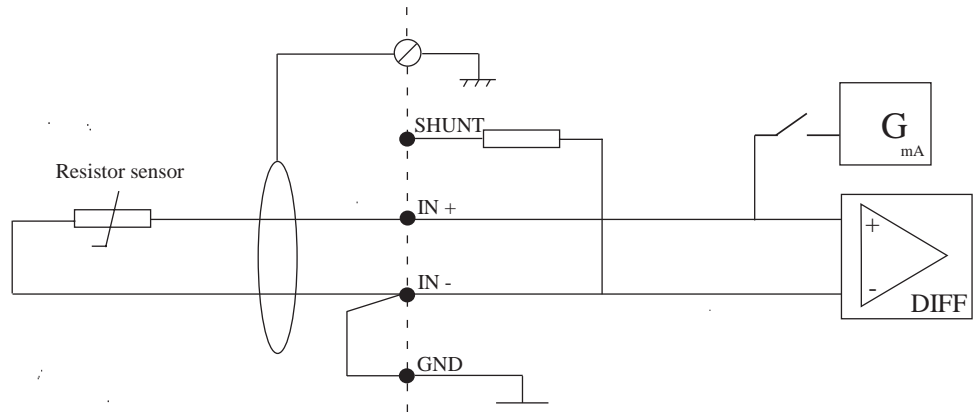

resist2w_b

Fig. 5.1.9.6.-5 Principle diagram of the two-wire connection

5.1.9.7. Attributes of an RTD/analog input for feeder terminal configuration

The value and the validity of the input can be issued for each RTD/analog input by the attributes AI# (REAL type) and AI#IV (BOOL type), where # denotes the number of the input. These attributes are available in the feeder terminal configuration and can be used for different purposes.

Value (AI#)

The AI# value represents the filtered absolute value of the physical input with the unit according to the selected measuring mode, that is, V, mA, Ω or $^{\circ}\text{C}$.

Invalidity (AI#IV)

The AI#IV attribute represents the invalidity status of the input. The attribute is set to FALSE when the value (AI#) is valid, and to TRUE when the value is invalid. The input is invalid when one or more of the following conditions are true: the measured value is outside the defined limits (see the parameters “Input high limit” and “Input low limit”), an open-loop condition is detected (only possible on resistance and temperature measuring modes) or the continuous recalibration of the module has failed. The value (AI#) is not locked when the invalid attribute is set to TRUE, that is, the invalid value is available for inspection.

5.1.9.8. RTD/analog input configuration example

The RTD/analog inputs are supported in the Relay Configuration Tool by the general measurement function blocks MEAI1...MEAI8. As an example, to monitor temperature using a PT100 sensor, the measured value of the RTD/analog input is connected to the function block by connecting the value attribute RTD1_6_AI1 to the RawAI input of the function block. The output HighAlarm is used to activate a relay contact when the temperature exceeds a preset limit. The measured temperature is displayed on the MIMIC view of the HMI by the connected MMIDATA1 function block. To avoid unnecessary activation of the relay contact in case of a fault, the corresponding invalid attribute of the RTD/analog input RTD1_6_AI1IV is connected to the IV input of the function block.

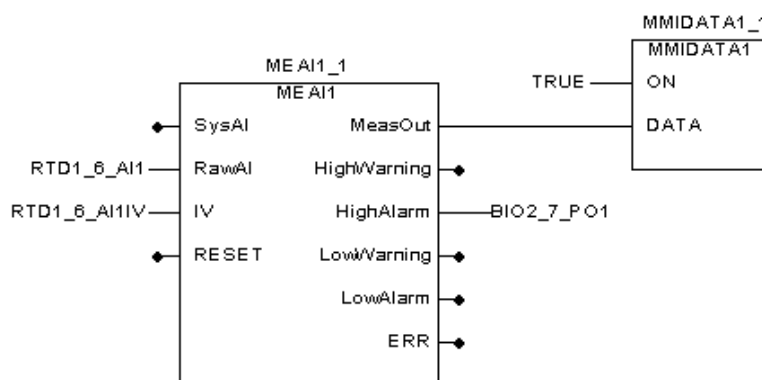

meaix1

Fig. 5.1.9.8.-1 RTD/analog input configuration example

5.1.9.9. Self-supervision

Each input sample is validated before it is fed into the filter algorithm. The samples are validated by measuring an internally set reference voltage immediately after the inputs are sampled. If the measured offset voltage deviates from the set value more than 1.5% of the measuring range, the sample is discarded. If the fault continues longer than for the set filter time, the invalid attributes of all inputs are set to TRUE to indicate a hardware fault. Should the measurement succeed later, the invalid attributes are reset to FALSE. This prevents most sudden hardware faults from affecting the measured value before the invalid attribute is set. To ensure that the specified measurement accuracy is met, a more thorough test of the hardware is performed by the continuous recalibration procedure which will catch errors that degrade the measurement accuracy.

5.1.9.10. Calibration

The RTD/analog module is calibrated at the factory. To be able to maintain the specified accuracy in spite of aging and varying temperature, the card also includes special hardware to allow self-recalibration on the field. This recalibration procedure runs continuously, even when no measurements are activated, to ensure that the card is always optimally calibrated. If the recalibration procedure fails, the reason is a hardware failure. In this case the card's measurement accuracy is no longer obtained, and the invalidity attributes of all inputs are set to TRUE. However, the card continues updating the measured input values, and if the invalidity attributes are not used in the feeder terminal configuration, the situation could go unnoticed. Should the recalibration succeed later, the invalidity attributes return to normal operation.

5.1.9.11. RTD temperature vs. resistance

For the resistance values of RTD sensors at specified temperatures, see the following table.

TEMP C°	Platinum TCR 0.00385			Nickel TCR 0.00618				Nickel TCR 0.00672	Copper TCR 0.00427
	Pt 100	Pt 250	Pt 1000	Ni 100	Ni 120	Ni 250	Ni 1000	Ni 120 US	Cu 10
-40.0	84.27	210.675	842.7	79.1	94.92	197.75	791	92.76	7.490
-30.0	88.22	220.55	882.2	84.1	100.92	210.25	841	-	-
-20.0	92.16	230.4	921.6	89.3	107.16	223.25	893	106.15	8.263
-10.0	96.09	240.225	960.9	94.6	113.52	236.5	946	-	-
0.0	100.00	250	1000	100.0	120	250	1000	120.00	9.035
10.0	103.90	259.75	1039	105.6	126.72	264	1056	-	-
20.0	107.79	269.475	1077.9	111.2	133.44	278	1112	134.52	9.807
30.0	111.67	279.175	1116.7	117.1	140.52	292.75	1171	-9	-
40.0	115.54	288.85	1155.4	123.0	147.6	307.5	1230	149.79	10.580
50.0	119.40	298.5	1194	129.1	154.92	322.75	1291	-	-
60.0	123.24	308.1	1232.4	135.3	162.36	338.25	1353	165.90	11.352
70.0	127.07	317.675	1270.7	141.7	170.04	354.25	1417	-	-
80.0	130.89	327.225	1308.9	148.3	177.96	370.75	1483	182.84	12.124
90.0	134.70	336.75	1347	154.9	185.88	387.25	1549	-	-
100.0	138.50	346.25	1385	161.8	194.16	404.5	1618	200.64	12.897
120.0	146.06	365.15	1460.6	176.0	211.2	440	1760	219.29	13.669
140.0	153.58	383.95	1535.8	190.9	229.08	477.25	1909	238.85	14.442
150.0	-	-	-	198.6	238.32	496.5	1986	-	-
160.0	161.04	402.6	1610.4	206.6	247.92	516.5	2066	259.30	15.217
180.0	168.46	421.15	1684.6	223.2	267.84	558	2232	280.77	-
200.0	175.84	439.6	1758.4	240.7	288.84	601.75	2407	303.46	-
220.0	-	-	-	259.2	311.04	648	2592	327.53	-
240.0	-	-	-	278.9	334.68	697.25	2789	353.14	-
250.0	194.07	485.175	1940.7	289.2	347.04	723	2892	-	-
260.0	-	-	-	-	-	-	-	380.31	-
300.0	212.02	530.05	2120.2	-	-	-	-	-	-
350.0	229.67	574.175	2296.7	-	-	-	-	-	-
400.0	247.04	617.6	2470.4	-	-	-	-	-	-
450.0	264.11	660.275	2641.1	-	-	-	-	-	-
500.0	280.90	702.25	2809	-	-	-	-	-	-
550.0	297.39	743.475	2973.9	-	-	-	-	-	-
600.0	313.59	783.975	3135.9	-	-	-	-	-	-

5.1.10. Analog outputs

The REF541 and REF543 feeder terminals equipped with an RTD/analog module have four general purpose 0...20 mA analog current outputs. All outputs are galvanically isolated from the supply and enclosure of the feeder terminal and from each other.

For technical data of the analog outputs, refer to Table 5.2.1-7 on page 90.

	REF541/REF543 + RTD1
Analog outputs	RTD1_6_AO1
	RTD1_6_AO2
	RTD1_6_AO3
	RTD1_6_AO4

The parameters and events for the analog outputs are included in the event and parameter lists on the CD-ROM “Technical Descriptions of Functions” (refer to Section “Related documents” on page 10).

5.1.10.1. Selection of analog output range

The outputs can be set to two different current ranges with the “Output range” parameters in the menu `Configuration/RTD1/Output #`.

Parameter	Values	Default
Output range	0 = 0...20 mA 1 = 4...20 mA	0...20 mA

5.1.10.2. Attributes of an analog output for feeder terminal configuration

The value and the validity of the output can be issued for each analog output by the attributes AO# (REAL type) and AO#IV (BOOL type), where # denotes the number of the output. These attributes are available in the feeder terminal configuration and can be used for different purposes.

Value (AO#)

The value written to AO# is transferred to a current signal at the output. The output response time is ≤ 85 ms, consisting of the software delay and the rise time of the analog output, counted from the moment when the value attribute is updated in the configuration program.

Invalidity (AO#IV)

The AO#IV attribute represents the invalidity status of the output. The attribute is set to FALSE when the value (AO#) is valid, that is, an equal amount of current is flowing through the output, and to TRUE when the value is invalid, that is, the current at the output is different from the value of AO#. When the AO#IV attribute is TRUE, this indicates one of two situations: either the current loop connected to the output is broken or the value attribute is written with a value outside the range defined by the “Output range” parameter. The transition of the AO#IV state may also generate an event. Event generation is controlled by the “Event mask” parameter found in the menu `Configuration/RTD1`.

The output behavior when the value attribute is outside the defined limits is as follows:

Output range	Value of AO#	Output current	Invalidity attribute AO#IV
0...20 mA	>20	20 mA	TRUE
	0...20	0...20 mA	FALSE
	<0	0 mA	TRUE
4...20 mA	>20	20 mA	TRUE
	4...20	4...20 mA	FALSE
	<4	0 mA	TRUE

Note that the output is also forced to 0 mA on the 4...20 mA range when the value is below the low limit. This behavior can be used to indicate a fault to the receiver.

5.1.10.3.

Analog output configuration example

The analog outputs are supported in the Relay Configuration Tool by the MEO1...MEO4 analog output function blocks. As an example, to display the measured value of neutral current on an analog gauge, the neutral current measurement block MECU1A is connected to MEO1, which in turn is connected to the RTD1_6_AO1 global variable. The output invalid signal RTD1_6_AO1IV is connected to the MMIALAR1 function block to achieve a visual indication of a fault. The MEO# function blocks contain the parameters necessary for scaling the measured value to fit the selected output range. The MEO# function blocks also limit the output change frequency to achieve a tolerable system load.

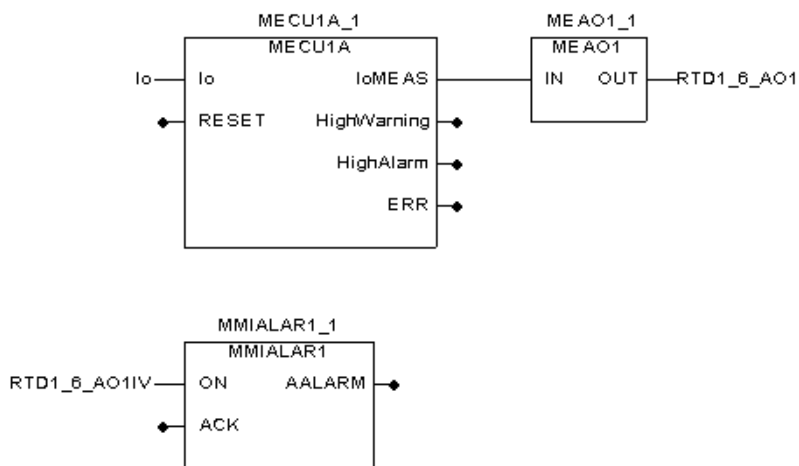

meaox1

Fig. 5.1.10.3.-1 Analog output configuration example

5.1.11. Trip circuit supervision

The trip circuit supervision inputs TCS1 and TCS2 in the REF 54_ feeder terminal consist of two functional units:

- A constant-current generator including the necessary hardware elements.
- A software-based functional unit for signalling.

The functional units are based on the CMTCS1 and CMTCS2 function blocks included in the condition monitoring category.

The supervision of the trip circuit is based on the constant-current injection principle. If the resistance of the trip circuit exceeds a certain limit, for instance due to bad contact or oxidation, or if the contact has welded, the voltage over the supervised contact falls below 20 V AC/DC (15...20V) and the supervision function of the trip circuit is activated. If the fault persists, the trip circuit supervision alarm signal ALARM is obtained once the preset delay time of the function block CMTCS_ elapses.

The input/output circuits are galvanically isolated from each other. The constant-current generator forces a 1.5 mA measuring current through the circuit-breaker trip circuit. The constant current generator is connected over the trip contact of the feeder terminal circuit. The current generator for the TCS1 is connected to the terminals X4.1/12-13 and the current generator for the TCS2 to the terminals X4.1/17-18 of the REF 54_ feeder terminal.

Under no-fault conditions, the voltage over the contact of the constant current generator must be above 20 V AC/DC.



The following instructions must be read very carefully.

Mathematically, operating condition can be expressed as:

$$U_c - (R_{ext} + R_{int} + R_s) \cdot I_c \geq 20Vac/dc$$

where

- U_c = operating voltage over the supervised trip circuit
- I_c = measuring current through the trip circuit, approximately 1.5 mA (0.99... 1.72 mA)
- R_{ext} = external shunt resistor value
- R_{int} = internal shunt resistor value, 1 k Ω
- R_s = trip coil resistance value

The resistor R_{ext} must be so calculated that the trip circuit supervision current through the resistor is low enough not to influence the trip coil of the circuit breaker. On the other hand, the voltage drop over the resistor R_{ext} must be low enough not to jeopardize the operating condition presented in the formula above.

Technical Reference Manual, General

The values in Table 5.1.11-1 are recommended for the resistor R_{ext} :

Table 5.1.11-1 Shunt resistor values for different operating voltages

Operating voltage U_c	Shunt resistor $R_{h_{ext}}$
48 V DC	1.2 k Ω , 5 W
60 V DC	5.6 k Ω , 5 W
110 V DC	22 k Ω , 5 W
220 V DC	33 k Ω , 5 W

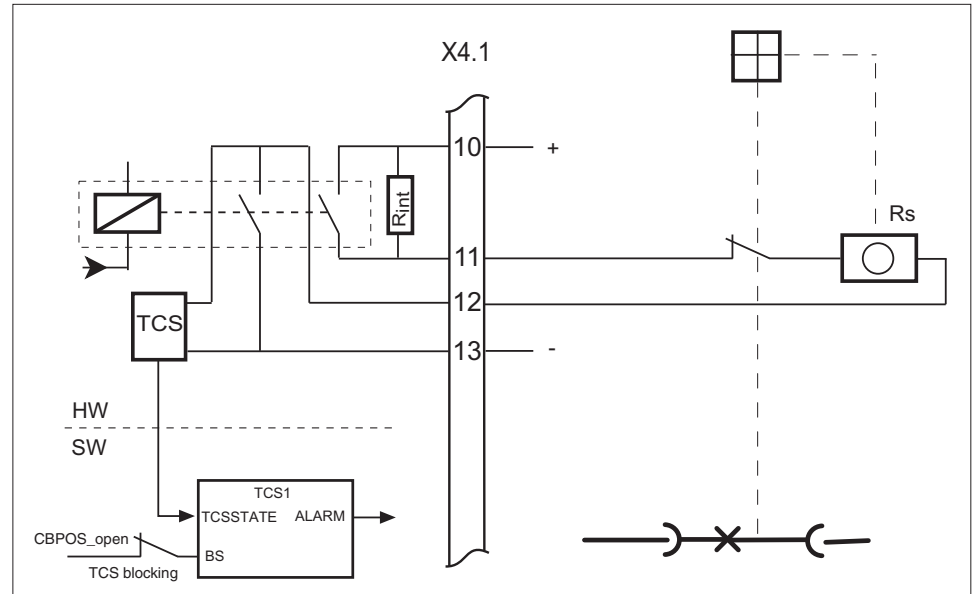

TCSclose_b

Fig. 5.1.11.-1 Operating principle of the trip-circuit supervision (TCS), without an external resistor. The TCS blocking switch is closed, blocking the TCS1 when the circuit breaker is open. The terminal numbers are related to HSPO1.

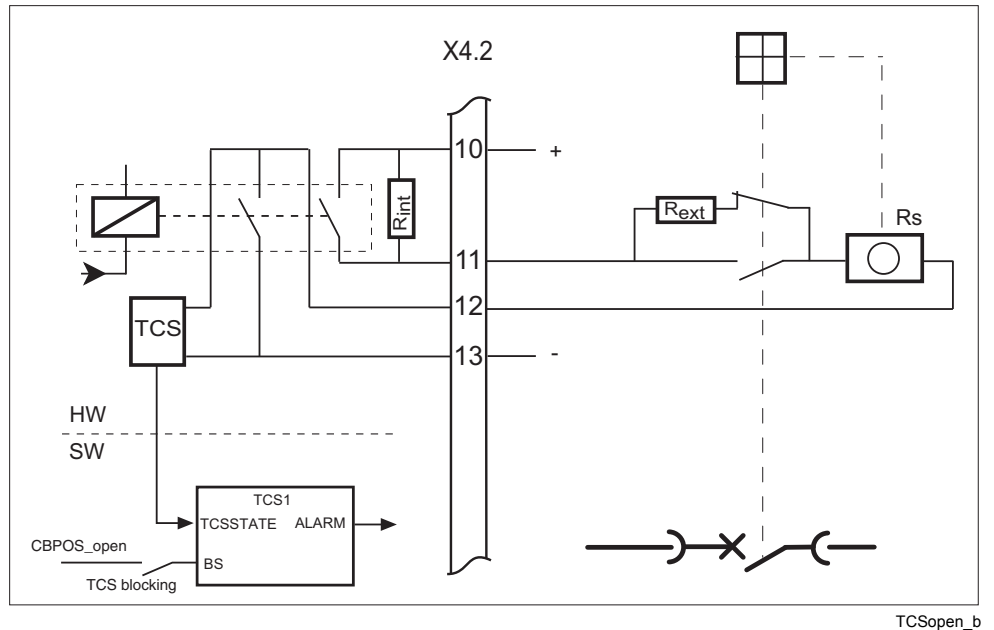

Fig. 5.1.11.-2 Operating principle of the trip-circuit supervision (TCS), with an external resistor. The TCS blocking switch is open, enabling trip-circuit supervision independent of circuit breaker position. The terminal numbers are related to HSPO1.

5.1.11.1.

Configuring the trip circuit supervision CMTCS_

The Relay Configuration Tool can be used to connect the trip circuit supervision input status signals to the function blocks CMTCS1 and CMTCS2. The configuration of the blocking signal is user-specific and can only be defined in the feeder terminal configuration. The trip circuit supervision inputs in the feeder terminal configuration are as follows:

TCS1 and TCS2 inputs in REF 541 and REF 543:

Trip Circuit Supervision 1 input	PS1_4_TCS1
Trip Circuit Supervision 2 input	PS1_4_TCS2

TCS1 and TCS2 inputs in REF 545:

Trip Circuit Supervision 1 input	PS2_4_TCS1
Trip Circuit Supervision 2 input	PS2_4_TCS2

For more information about the trip circuit supervision function, refer to the CD-ROM “Technical Descriptions of Functions”.

5.1.12.

Self-supervision (IRF)

The REF 54_ feeder terminal is provided with an extensive self-supervision system. The self-supervision system handles run-time fault situations and informs the user of faults via the HMI and LON/SPA communication. See also Table 5.2.1-12 on page 93.

5.1.12.1.**Fault indication**

The self-supervision signal output operates on the closed circuit principle. Under normal conditions the output relay is energized and the contact gap 3-5 is closed. Should the auxiliary power supply fail or an internal fault be detected, the contact gap 3-5 is opened.

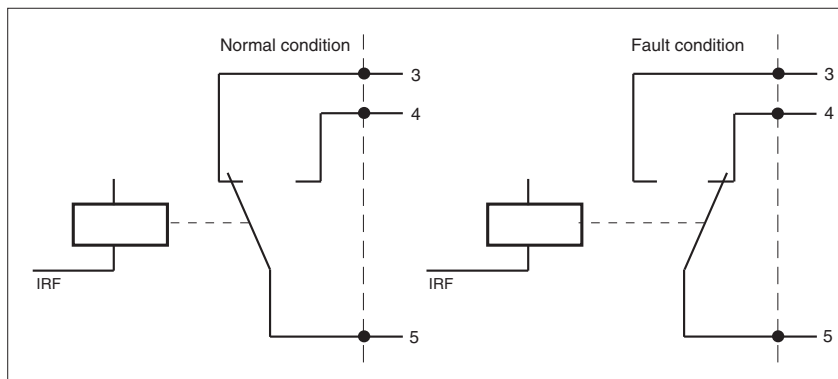

IRFOutput_b

Fig. 5.1.12.1.-1 Self-supervision output (IRF)

When a fault has been detected, the green Ready indicator starts blinking, a fault indication text is displayed on the HMI and an event 0/E57 is generated. The fault indication text on the HMI consists of two rows: a general message 'internal fault', followed by the generated IRF code of the fault as shown below¹:



irf

Fault indication has the highest priority on the HMI and can not be overrun by any other HMI indication. The fault indication text is displayed until cleared by pressing the C button for 2 seconds. Then the green READY indicator still remains blinking.

5.1.12.2.**Fault operation**

When entering IRF state the relay will take the following actions to ensure that a false trip can not be caused by the fault:

- All relay outputs will be forced to zero (released), and subsequent changes blocked.
- All virtual outputs (COMM_OUT1...32) will be written to zero, and subsequent changes blocked.
- The analog outputs will freeze at the current value.
- Event transmission will be blocked, except for IRF events E56/E57 and startup event E50.

1. Applies only to the feeder terminal revisions of Release 2.5 or later.

5.1.12.3. **Fault recovery¹**

The relay will try to recover from a fault either by restarting the module (I/O module or HMI) that reported the fault, or by restarting the whole relay. During restarting the IRF state will remain active until the internal self supervision program has determined that the relay is operating normally. If the fault is still persistent after restarting three times, the relay will be in permanent IRF state.

When returning to normal operation, the indication text will be replaced by this text: ‘internal fault *CLEARED*’, and the green READY indicator will return to steady state. In addition, an event 0/E56 is generated over the serial communication.

5.1.12.4. **Fault codes**

When an internal fault appears in REF 54_, the self-supervision system generates an IRF code that indicates the type of the fault. The fault code can be read from the feeder terminal main menu *Status/General/IRF code*. The fault code is also delivered as event data with the IRF event if LON communication is in use. The code indicates the first internal fault detected by the self-supervision system. The fault code can be read from the menu even though the relay has returned to normal operation.



Do not reset the feeder terminal before reading the IRF code. The code should be noted when overhaul is ordered. In case of a repeating IRF, send the relay to the manufacturer.

The following table gives an overview of the fault origin.

Codes	Explanation
0 ->	Faults related to a module of the feeder terminal, such as the MIMIC card, BIO/PS cards and RTD/analog module
3000 ->	Faults related to the parameter database
6000 ->	Faults related to the analog measurement inputs
7000 ->	Software faults
15000 ->	Faults related to testing

5.1.13. **Serial communication**

The feeder terminal has three serial communication ports, one on the front panel and two on the rear panel.

Serial communication port assignment

The bus communication protocol for the rear interface RS-232 (connector X3.2) is selected via the “Protocol 2” setting parameter and the bus communication protocol for the rear interface RS-485 (connector X3.3) is selected via the “Protocol 3” setting parameter. These parameters can be modified by using the local menu (*Communication/General*) or by using the Relay Setting Tool.

The following table shows supported parallel communication protocols on the front and the rear connectors of the REF 54_ feeder terminals.

1. This feature is supported in the feeder terminal revisions of Release 2.5 or later.

Connectors/Communication parameters		
X3.2/Protocol 2	X3.3/Protocol 3	Front connector
SPA (SMS)	LON	SPA
SPA (SMS)	SPA	-
IEC_103	LON (SMS)	SPA
IEC_103	SPA (SMS)	-
IEC_103	-	SPA
DNP 3.0	LON (SMS)	SPA
DNP 3.0	SPA (SMS)	-
DNP 3.0	-	SPA
Modbus	LON (SMS)	SPA
Modbus	SPA (SMS)	-
Modbus	-	SPA
IEC 61850	LON (SMS)	SPA
IEC 61850	SPA (SMS)	-
IEC 61850	-	SPA
Profibus	LON (SMS)	SPA
Profibus	SPA (SMS)	-
Profibus	-	SPA
-	SPA	SPA



Equipment connected to the rear communication ports X3.2 and X3.3 should be galvanically isolated from the terminal.

5.1.13.1.

SPA/IEC_103 communication on the rear connector X3.2

The 9-pin D-type subminiature male connector (RS-232 connection) on the rear panel connects the feeder terminal to the distribution automation system via the SPA bus or the IEC_103. The fibre-optic interface module type RER 123 is used for connecting the feeder terminal to the fibre-optic communication bus for SPA and IEC_103 protocol.

5.1.13.2.

DNP 3.0/Modbus communication on the rear connector X3.2 ¹

The 9-pin D-type subminiature male connector (RS-232 connection) on the rear panel connects the feeder terminal to the distribution automation system via the DNP 3.0 or the Modbus protocol. The interface between the feeder terminal and a RS-485 communication bus can be made through the RER 133 Bus Connection Module. The interface between the feeder terminal and an optical bus can be made through the RER 123 Bus Connection Module.

1. DNP 3.0 and Modbus communication is supported in the feeder terminal revisions of Release 3.0 or later (using RER 133) and Release 3.5 or later (using RER 123).

5.1.13.3. IEC 61850 communication by using SPA-ZC 400 on the rear connector X3.2

The 9-pin D-type subminiature male connector (RS-232 connection) on the rear panel connects the feeder terminal to the distribution automation system via the IEC 61850 protocol. In the IEC 61850 mode, the SPA-ZC 400 Bus Connection Module is needed.

In the IEC 61850 mode, the baud rate for relay port X3.2 is set to 38400. Furthermore, the mode includes a limited IEC 61850 GOOSE message support when available in SPA-ZC 400.

5.1.13.4. Profibus-DPV1 communication by using SPA-ZC 302 on the rear connector X3.2

The 9-pin D-type subminiature male connector (RS-232 connection) on the rear panel connects the feeder terminal to the distribution automation system via the Profibus protocol. The interface between the feeder terminal and Profibus can be made through the SPA-ZC 302 Gateway.

In the Profibus mode, the baud rate for relay port X3.2 is set to 38400. The SPA-CZ 302 Gateway should be set to the same baud rate. If the SPA-ZC 302 Gateway is connected to multiple terminals, the “Protocol 2” parameter should be set to SPA mode and the SPA baud rate for port X3.2 to 19200.

5.1.13.5. LON/SPA bus communication on the rear connector X3.3

The 9-pin D-type subminiature connector (RS-485 connection) on the rear panel connects the feeder terminal to the distribution automation system via the SPA bus or the LON bus. The fibre-optic interface module type RER 103 is used to connect the feeder terminal to the fibre-optic communication bus. The module RER 103 supports both SPA bus and LON bus communication.

The other communication parameters for the rear interface RS-485 are set also via the Communication menu.

5.1.13.6. Front panel optical RS-232 connection for a PC

The optical connector on the front panel isolates the PC galvanically from the feeder terminal. The front connector for the PC is standardized for ABB relay products and requires a specific opto cable (ABB art. No 1MKC950001-2). The cable is connected to the serial RS-232 port of the PC. The other communication parameters for the rear RS-485 interface are also set in the Communication menu of the REF 54_ feeder terminal.

The front panel is intended for the connection of a PC for configuring the feeder terminal with the CAP 50_ tools. The front interface uses the SPA bus protocol.

5.1.13.7. Communication parameters

SPA

The SPA bus protocol uses an asynchronous serial communication protocol (1 start bit, 7 data bits + even parity, 1 stop bit) with adjustable data transfer rate; Baud rate (default 9.6 kbps) and SPA address (slave number).

The SPA communication parameters are the same for communication via the front optical RS-232 and the rear RS-485 connectors. The SPA address is the same also for transparent SPA communication on the LON.

Parameter	Value	Default value	Explanation
SPA address	0...999	1	Slave number for communication
Baud rate	4800; 9600; 19200 bps	9600	Data transfer rate for communication
Rear connection	Connect		Activate rear SPA connection ¹⁾

1) This functionality is valid only in the feeder terminal revisions of releases prior to Release 2.0. The parameter is accessible only via serial communication. SPA communication on the front connector inhibits the rear X3.3 SPA communication and the transparent SPA communication on the LON protocol and remains inhibited for one minute after the SPA communication has stopped. It is possible to release this blocking situation by writing the value 1 to the V202 variable.

LON

Adjustable LON serial communication parameters are Subnet number, Node number and Bit rate.

Parameter	Value	Default	Explanation
Subnet number	1...255	1	LON subnet number
Node number	1...127	1	LON node number
Bit rate	78.1; 1250 kbps	1250	LON communication speed

The bit rate 1250 kbps on the LON protocol is used for the optical serial communication network using the RER 103 module connected to the X3.3 connector.

IEC_103

Adjustable IEC_103 serial communication parameters are shown in the table below.

Parameter	Value	Default	Explanation
Unit address	1...254	1	IEC_103 station address
Baud rate	9600, 19200	9600	Communication speed
Function type	0...255	160	Unit function type
Scale factor	1.2 or 2.4	1.2	Analog value scale factor
Frame type	0...17 ¹⁾	0	Measurement frame type
RTD data frame	0 or 1 ¹⁾	0	If RTD data frame is on, it is sent to class 2 data poll every second.

1) Refer to Table 9.5.-3 on page 124

The IEC_103 protocol is used for the optical serial communication network using the RER 123 module connected to the X3.2 connector.

The unit address is used for identifying the device from the protocol point of view.

For more information, see Table 5.2.1-11 on page 92.

DNP 3.0

Adjustable DNP 3.0 serial communication parameters are shown in the next table.

Parameter	Value	Default	Explanation
Unit address	0..65532	1	Address of the REF 54_ unit in the DNP 3.0 network. Must be the same as configured in the master station.
Master address	0..65532	2	Address of the master station (destination address for unsolicited responses). Must be the same as configured in the master station.
Primary data link timeout	100...10000 [ms] ¹⁾	300	This timeout is used when REF 54_ sends data using service 3 (user data with confirmation). The timeout must be set according to communication speed.
Primary data link layer retransmission count	0...100	0	Number of retransmissions on data link layer when REF 54_ sends spontaneous data.
Application layer timeout	1000...10000 [ms] ¹⁾	1000	This timeout is used when REF 54_ sends messages with confirmation request. The timeout must be set according to communication speed.
Application layer retransmission count	0...100	0	Number of retransmissions on the application layer when REF 54_ sends messages with confirmation request.
Confirmation on data link layer	0...1 [0=disabled; 1=enabled]	0	Enable/disable confirmations on data link layer.
Confirmation on application layer	0...1 [0=disabled; 1=enabled]	0	Enable/disable confirmations on application layer.
Default variation of binary input object	1...2	2	
Default variation of binary input change event object	1...3	2	
Default variation of binary output object	1...2	2	
Default variation of counter object	1...2	1	
Default variation of counter event object	1...2	1	
Default variation of analog input object	1...2	1	
Default variation of analog input event object	1...2	1	
Default variation of analog output status object	1...2	1	
Class 1 event delay	0...1000 [s]	1	Delay for spontaneous event reporting for class 1
Class 1 event. count	1...32	1	Event count for spontaneous event reporting for class 1
Class 2 event delay	0...1000 [s]	1	Delay for spontaneous event reporting for class 2

Technical Reference Manual, General

Parameter	Value	Default	Explanation
Class 2 event count	1...32	1	Event count for spontaneous event reporting for class 2
Class 3 event delay	0...1000 [s]	1	Delay for spontaneous event reporting for class 3
Class 3 event count	1...32	1	Event count for spontaneous event reporting for class 3
Unsolicited reporting mode ²⁾	0...3 [0=unsolicited responses are disabled; 1=send messages immediately; 2=first send empty UR and wait for confirmation, then send data filled URs; 3=first send empty UR and wait for confirmation, wait for enable UR from master and then send data filled URs]	0	Unsolicited messages reporting behavior
Time synchronization mode	0...2 [0=Never; 1=Periodic; 2=Startup]	2	See DNP 3.0 Remote Communication Protocol for REF 54_ manual (1MRS755260).
Baud rate	0...6 [0=300; 1=600; 2=1200; 3=2400; 4=4800; 5=9600; 6=19200]	5	Communication speed of DNP protocol
Number of stop bits	1...2	1	
Next character timeout	0...65535 [ms] ¹⁾	0	
End of frame timeout	2...65535 [ms] ¹⁾	10	
Parity	0...2 [0=None; 1=Odd; 2=Even]	0	
Silent interval	10...65535 [ms]	20	Collision detection ³⁾
Time slot width	10...65535 [ms]	10	Collision detection ³⁾
Number of time slots	1...255	8	Collision detection ³⁾
Collision detection enabled	0...1 [0=Disabled; 1=Enabled]	0	Collision detection ³⁾
Protocol mapping diagnostic parameter			DNP protocol mapping file
Protocol mapping diagnostic parameter			Total entries counter
Protocol mapping diagnostic parameter			Number of entries not in use
Protocol mapping diagnostic parameter			Number of entries with invalid, uncorrectable contents (INV)
Protocol mapping diagnostic parameter			Number of entries with corrected contents (COR)
Protocol mapping diagnostic parameter			Number of entries referring to nonexistent block (NBL)

Technical Reference Manual, General

Parameter	Value	Default	Explanation
Protocol mapping diagnostic parameter			Number of entries referring to invalid objects from existing block (NOB)
Protocol mapping diagnostic parameter			Number of entries translated into protocol mapping
Protocol mapping diagnostic parameter			Protocol mapping name
Collision counter	0..65535	0	Collision detection ³⁾
Frame error counter	0..65535	0	
Parity error counter	0..65535	0	
Overrun error counter	0..65535	0	

- 1) When using communication speeds below 1200 bits/s, be sure to set the values for parameters to values above the time it takes for one character to be sent. Note that if the values are not correctly set, the sent messages will be lost.
- 2) If parameter F503V024, Unsolicited reporting mode, is set to "0", REF 54_ responds to an Enable Unsolicited Reporting request with the Internal indication IIN2.0 (Function Code Not Supported) bit set.
- 3) See the manual DNP 3.0 Remote Communication Protocol for REF 54_ and RET 54_.

Modbus

The Modbus protocol has two serial transmission modes: ASCII and RTU. These modes define the bit contents of the message fields transmitted in the network. Adjustable Modbus serial communication parameters are shown in the table below.

Parameter	Value	Default	Explanation
Unit address	1...247	1	Address of the REF 54_ in the Modbus network. Must be same as configured in the master station.
CRC order	0/1 [0=LO/HI, 1=HI/LO]	0	The order of CRC bytes in protocol frame. Not used in ASCII mode
Protocol mode	0/1 [0=ASCII, 1=RTU]	1	Chooses whether the REF 54_ uses ASCII or RTU mode.
Password	ASCII codes	4 space characters	Password for control operations
Protocol mapping diagnostic parameter		0	Total entries counter
Protocol mapping diagnostic parameter		0	Number of entries not in use
Protocol mapping diagnostic parameter		0	Number of entries with invalid, uncorrectable contents (INV)
Protocol mapping diagnostic parameter		0	Number of entries with corrected contents (COR)
Protocol mapping diagnostic parameter		0	Number of entries referring to nonexistent block (NBL)
Protocol mapping diagnostic parameter of NOB entries		0	Number of entries referring to invalid objects from existing block (NOB)
Protocol mapping diagnostic parameter		0	Number of entries translated to operational protocol mapping
Baud rate	0...6 ^{1) 2)} [0=300 1=600 2=1200 3=2400 4=4800 5=9600 6=19200]	6	

Technical Reference Manual, General

Parameter	Value	Default	Explanation
Number of stop bits	0...2 ³⁾	1	
Next character timeout	0=Not in use, 2...65535 [ms] ¹⁾	1000 (ASCII) 0 (RTU)	
End Of Frame timeout	2...65535 [ms] ²⁾	1000 (ASCII) 2 (RTU)	
Parity	0...2 ³⁾ [0=None 1=Odd 2=Even]	2	
Number of data bits	5...8	7 (ASCII) 8 (RTU)	
Frame error counter	0...65535	0	Frame error counter ⁴⁾
Parity error counter	0...65535	0	Parity error counter ⁴⁾
Overrun error counter	0...65535	0	Overrun error counter ⁴⁾
Protocol mapping diagnostic parameter			Protocol mapping name
Protocol mapping diagnostic parameter			Modbus protocol mapping file

1) The change of Baud rate parameter value forces an automatic update of the Next character timeout parameter value to 1,5 character times. If the timeout value is lower then 2ms then it is disabled (set to 0 - not in use).

2) The change of Baud rate parameter value forces an automatic update of End Of Frame timeout parameter value to 3,5 character times.

3) The change of Parity parameter value forces an automatic update of the number of stop bits to 1, with parity used, and to 2 for parity none.

4) The counters are 16 bit cyclical counters, after reaching 0xFFFF (65535) next increment changes the value back to 0x0000. The default setting is reset to 0 at system start.

5.1.13.8.**Parallel communication support**

When SPA is used, the rear side communication is not stopped when the front connector is “active”. This enables for example uploading the disturbance records without affecting the communication to upper level.

Moreover, if LON is selected as a communication protocol and the front connector is “active”, transparent SPA write commands are not inhibited via the LON bus.¹

5.1.13.9.**System structure**

The system very often resembles the system in the following figure. The protection, control or alarm functions are implemented by using REF 54_ feeder terminals, SPACOM units or other SPA bus devices (devices connected to the system via the SPA bus). Generator or motor feeders are protected and controlled with REF 54_ feeder terminals. LON devices made by other manufacturers or other ABB companies may be used for various DI, AI and DO functions. MicroSCADA is used for remote control.

1. Parallel communication is restricted in releases prior to Release 2.0, refer to Section “Release 2.0” on page 107.

Technical Reference Manual, General

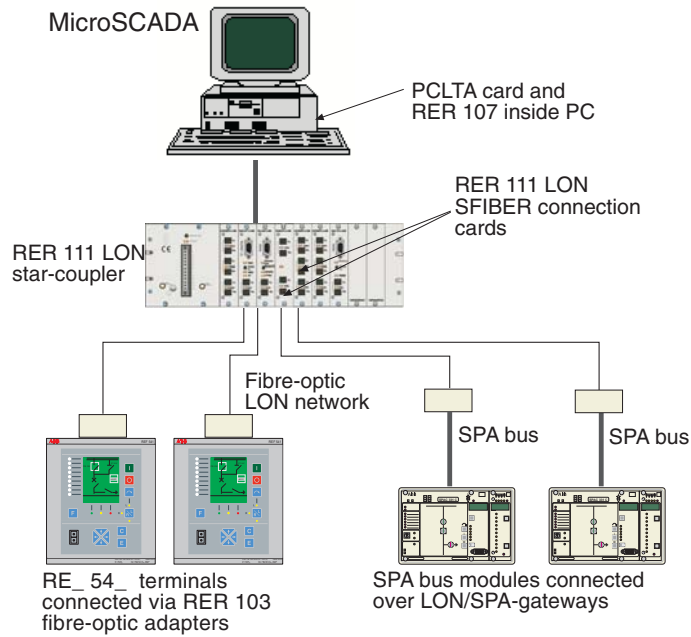

A050742

Fig. 5.1.13.9.-1 Example of a LON-based substation automation system

In the system described in the figure above, communication is usually arranged as shown in the table below.

Table 5.1.13.9-1 Communication arrangement example

Data type	REF <-> MicroSCADA	REF and LSG devices to each other
Control commands	transparent SPA bus messages	-
Events and alarms	sliding window protocol	-
State of breakers and isolators	sliding window protocol	network variables
Analog measurement values	sliding window protocol	-
Other DI, AI data	sliding window protocol	network variables
Other DO, AO data	transparent SPA bus messages	network variables
Parameter data	transparent SPA bus messages	-
SPA file transfer data	transparent SPA bus messages	-

Other supported system configurations are represented in the following figures. A LON bus and a parallel “SMS” bus connected as a SPA loop using the interface module RER 123 on connector X3.2, allows to implement the redundant SMS workstation.

Technical Reference Manual, General

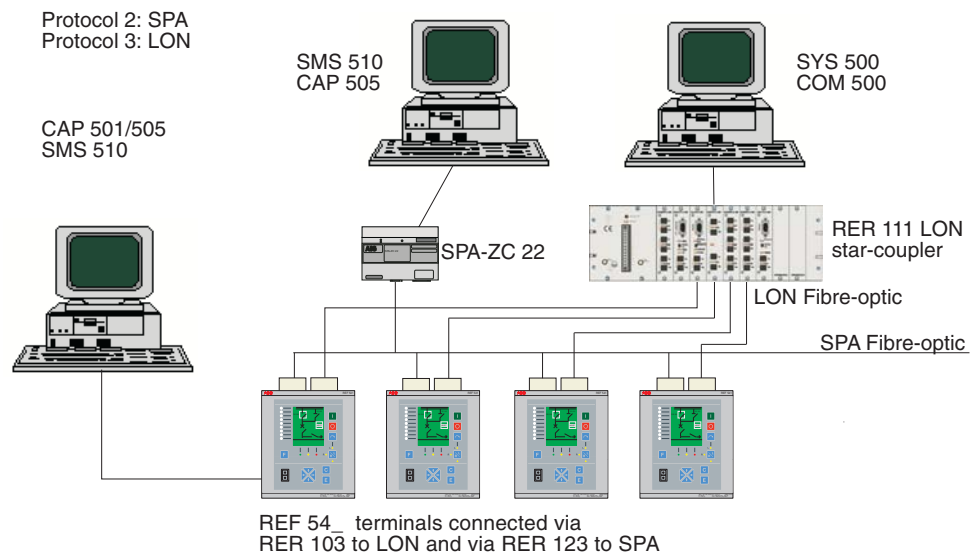

A050772

Fig. 5.1.13.9.-2 LON- and SPA-based substation automation system

The REF 54_ feeder terminals are connected to the IEC_103 master device using RER 123 on connector X3.2.

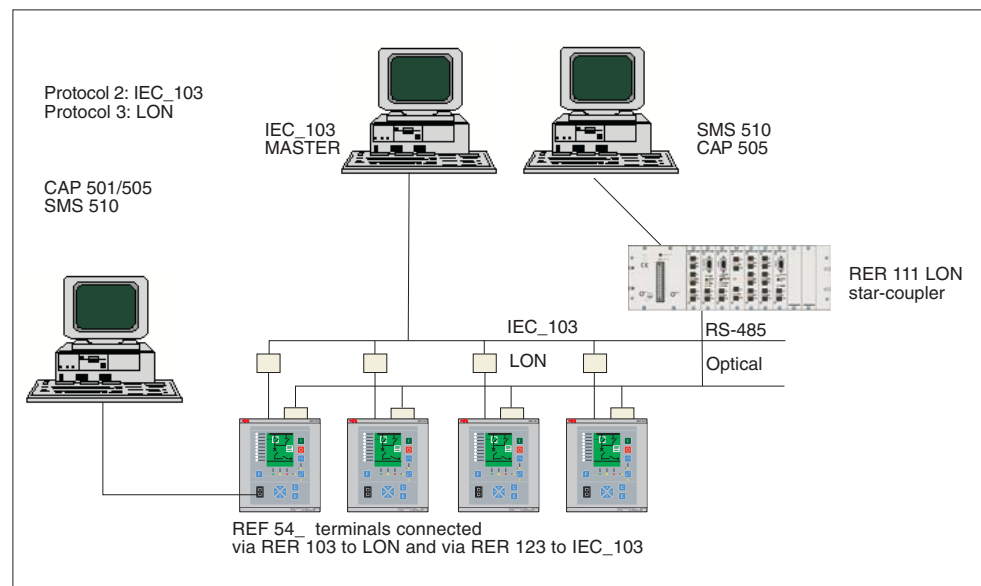

A050773

Fig. 5.1.13.9.-3 IEC_103- and LON-based substation automation system

Technical Reference Manual, General

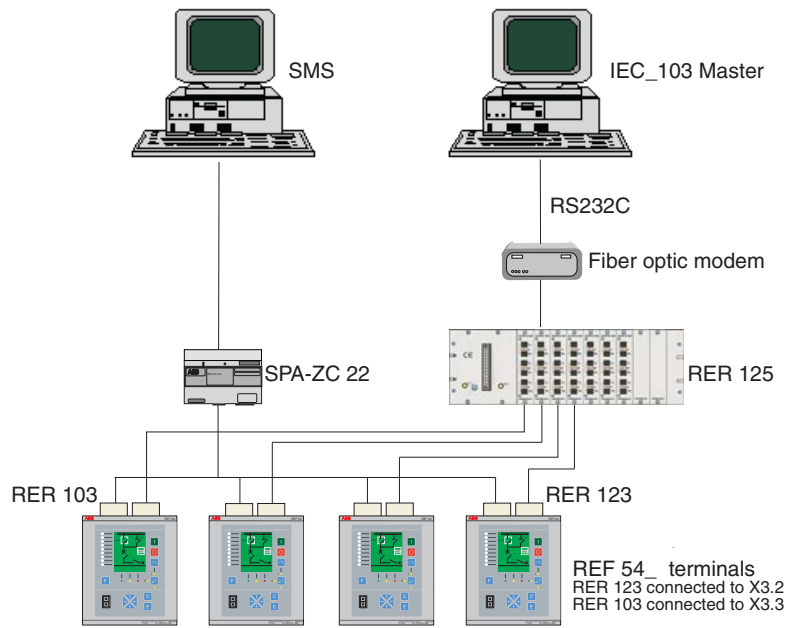

A050774

Fig. 5.1.13.9.-4 IEC_103- and SPA-based substation automation system

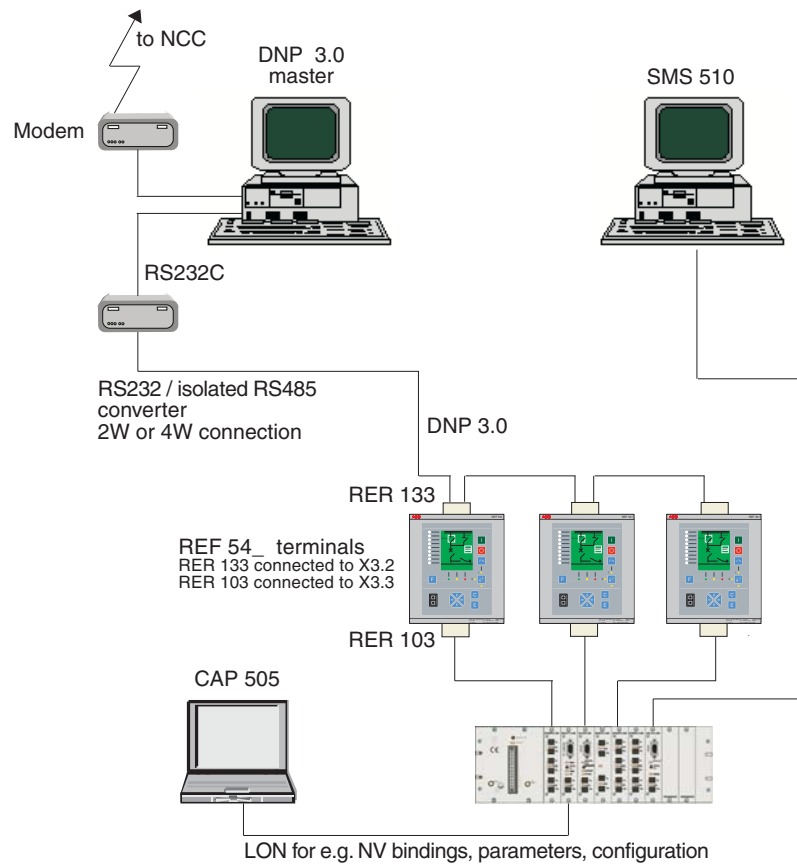

A050775

Fig. 5.1.13.9.-5 DNP 3.0- and LON-based substation automation system

Technical Reference Manual, General

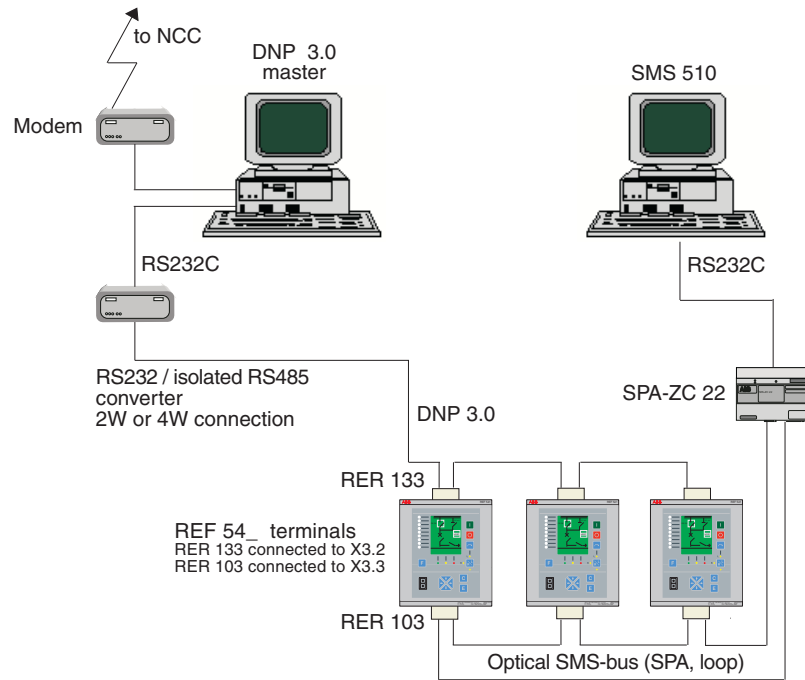

A050776

Fig. 5.1.13.9.-6 DNP 3.0- and SPA-based substation automation system

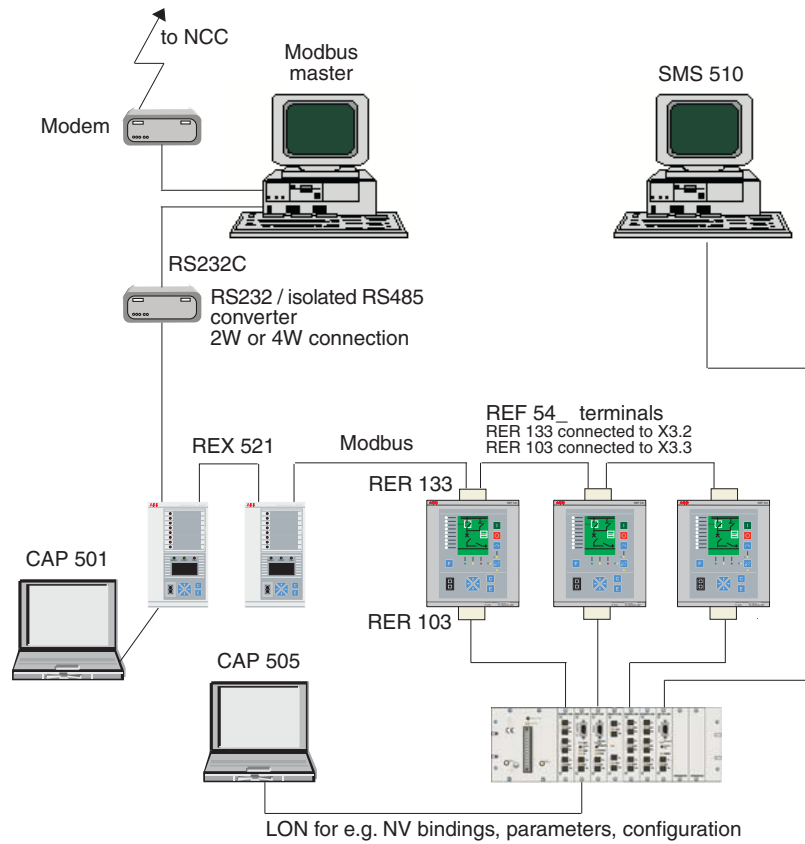

A050777

Fig. 5.1.13.9.-7 Modbus- and LON-based substation automation system

