

Effective: September 1996
Supersedes D.B. Dated December 1995
Mailed to: E, D, C/40-100C, 41-400B

Multi-Zoned Distance

Device Number: 21, 21N,
21NP, 21P,
02, 67/67N,
50/51N

REL 300 (MDAR) Numerical Transmis- sion Line Protection



BASIC SYSTEM

Standard Functions

- 100% Numerical Processing
- Three Zone Distance Relay. Zone 3 Reversible (21, 21N, 21S).
- Independent Timers for Phase and Ground (Zone 1, Zone 2 and Zone 3) (02)
- Four Impedance Units Per Zone (1 Phaseto-Phase Unit and 3 Phase-to-Ground Units)
- Inverse Time, Directional/Non-Directional (Selectable) Overcurrent Ground Characteristic (67N/51N)
- Overcurrent Supervision of Ground Distance Units (50 FD)
- High Set Overcurrent Phase and Ground Trip Units (50 HS, 50N HS)
- Power Swing Block (68)
- Close into Fault Detection and Tripping
- Unequal Pole Closing Load Pickup Logic
- Selectable Load Loss Accelerated Trip
- Zone 1 Non-Pilot Extension Scheme
- Loss of Potential Supervision Block Distance Tripping Only and/or Alarm Block All Tripping and/or Alarm

FEATURES

- Loss of Current Monitoring
- Fault Locator Function
- Unique Faulted Phase Selector for Logic Control and Targeting
- Self Check Function

- Monitoring of Voltage, Current and Power Factor Angle (Metering)
- Unique Current Change Fault Detector
- Man-Machine Interface Includes:
2-Four Character Vacuum Fluorescent Displays (With Screen Saver Blanking Feature)
6-Pushbuttons For Data Entry/Retrieval
6-LEDs For Targeting and Relay Status
Sealable Settings, Entry Pushbutton
- RS-232C Communications Interface
- 19-inch Rack Mounting - 4 Rack Units High or FT-42 Case
- 1 Ampere or 5 Ampere Current Transformer Operation
- 50/60 Hz
- Drawout Construction

Optional Functions

- Pilot System - includes additional zone of phase and ground distance (21P, 21NP) plus the following logic functions:
 - Logic for Block, Unblock, POTT, PUTT
 - Three Terminal Line Capability
 - Transient Block Capability
 - Carrier Signal Continuation
 - Weak Feed Capability
- Ft-14 Test Switches
- Single Pole Trip Logic and Trip Outputs
- Standard RS-232C Interface can be replaced with an INtegrated COMmunications (INCOM[®]) Product Operated Network Interface (PONI) when networking is desired. Networking requires a Basic Interface to Remote Ter-

terminal (BIRT) or an INCOM[®]-based Multi Access Controller (IMAC) to act as a network controller.

- Standard RS-232C Interface can be replaced with RS-232C Interfaces With IRIG-B Time Synchronization Port
- Software for Oscillographic Data Analysis (16 Events)
- 8 Programmable Output Contacts (Available With 3 Pole Trip Version Only)
- Magneto-Optic Current Transducer (MOCT) Input Interface

APPLICATION

MDAR is a numerical transmission line protection system with three or four zones of distance protection, optional pilot zone logic, metering, a fault locator and self diagnostics. All measurements and logic use microprocessor technology. MDAR is recommended for protection of transmission lines where to 1¹/₂-2 cycle relaying time is acceptable.

MDAR can be applied as a pilot or non-pilot system and includes Zone 1 extension and loss-of-load accelerated trip logic. It can be used on 2 and 3 terminal lines including weak feed terminals.

For lines where power swings can occur, MDAR includes out-of-step blocking functions. One set of blinders functions to restrict three-phase distance elements from operating on heavily loaded long lines. The phase-to-phase elements are unaffected by power swings.

In certain situations, systems operations may be enhanced by single pole tripping thus allowing load flow over the unfaulted phases. MDAR provides optional single pole tripping hardware and logic.

When the single pole trip option is not selected extra programmable output contacts may be added for indication and/or tripping functions. There are internal logic signals to choose from.

- MDAR records up to 16 fault records and provides indication and fault location.
- An RS-232/PONI provides remote communications for accessing data and remote setting changes.
- Option: oscillographic data function provides 1 cycle of pre-fault and 7 cycles of fault data for up to 16 faults.

These added data features facilitate system protection operation analysis.

- The self checking functions improve relaying reliability and availability while reducing maintenance requirements.
- Draw-out construction and optional FT test switches improve testing and maintenance functions.

DESIGN

The MDAR design is compact, flexible and easy to use. Its numerical design provides complete system protection and self supervision. The microprocessor checks itself, the peripheral circuitry, A/D converter calibration, RAM, NOVRAM and EPROM memories and the power supply. In addition it monitors the ac inputs and provides indication for LOP (Loss of Potential) and LOI (Loss of Current). The self-checking feature improves reliability by reducing or eliminating periodic maintenance requirements. MDAR combines precise measurements and years of experience.

The MDAR Operator Interface Panel offers both ease-of-use and powerful capability. There are two four-digit alphanumeric displays that show up to 62 separate settings, plus seven indicating LEDs. It is easy to access stored data and easy to input new data. In addition, MDAR provides fault designations and fault location information. The metering display shows three-phase voltage, current, load angle, and signal monitoring.

Fully digital design gives MDAR a level of flexibility uniquely capable of meeting the most complex transmission line protection requirements. The flexibility begins with three zones of phase and ground distance protection. Zones 1 and 2 are forward set, Zone 3 is optionally reversible. There is an independent pilot zone.

MDAR has a built in fault locator which indicates the distance to the fault in either miles or kilometers and in ohms. It stores fault records for up to 16 faults. Each record contains information on which MDAR units operated, fault location, prefault voltage, current and angle and fault values of voltage, current and angles.

The MDAR has eight modes of operation:

- Non pilot zone distance
- Zone 1 extension
- Blocking
- Permissive underreach transfer trip
- Permissive overreach transfer trip
- Permissive overreach transfer trip with weak feed
- Unblocking
- Unblocking with weak feed

The backup time overcurrent ground protection can be directional or non-directional. Its characteristic curve, pickup value and time dial setting

can be selected from the front panel.

MDAR has been designed to offer maximum benefits with minimum disruption to existing installations. Application is universal. MDAR accepts 1A or 5A current transformers, 50 or 60 Hertz. For pilot teleprotection systems, MDAR provides a universal channel interface. It features:

- Isolated contact inputs and outputs
- Transient block/unblock circuitry
- Three terminal line capability
- Carrier signal continuation and weak feed capability.

The dc-dc converter power supply offers exceptionally high reliability. It features a loss-of-power indicator and alarm. It provides complete protection from overvoltage and overcurrent. Power supply test points are conveniently located on the front panel. The power supply is available in three ranges:

- 48/60 Vdc
- 110/125 Vdc
- 220/250 Vdc

MDAR offers high-speed tripping. The minimum trip time is 12-14 milliseconds. Typical trip time is 22 milliseconds.

The MDAR features an optically isolated RS-232C communications port as standard. The MDAR can be easily networked with other protection and control devices in the substation by simply replacing the RS-232C interface with an optional ABB INCOM[®] interface. This allows networking of up to 2500 devices in a substation.

Operating Principles

The R-X Diagram, (Figure 1) illustrates the MDAR impedance characteristics. Zone 1 phase and ground settings are chosen to provide substantial coverage of the protected line without overreaching the next bus. A setting of 75 to 85% of the line impedance is typical. Faults occurring within the reach of the Zone 1 measurement cause direct tripping. The user can select to add a two cycle time delay to Zone 1 trip.

Zone 2 settings are chosen to assure that faults occurring on the next bus are recognized. Settings are generally chosen (independent of the Zone 1 settings), to be 120 to 150% of the line impedance. Any fault occurring on the protected line will be recognized by this Zone 2 measurement (within the fault resistance and current limitations of the relaying system). Zone 2 tripping occurs with separate phase and ground delay timers (T2P and T2G.)

There is an optional, independent pilot zone which functions with the user selected pilot logic. It is typically set to 120 to 150% of the protected line impedance. It provides high speed tripping subject to the pilot system logic and channel.

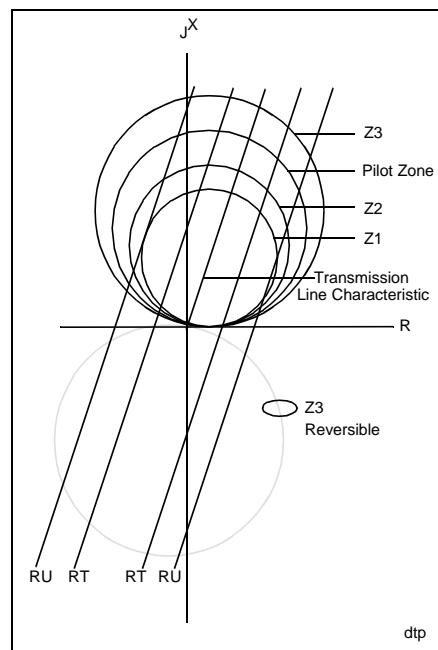

Figure 1

The Zone 3 measurement is directional, and may be chosen to respond to forward or reverse faults. The reverse sensing option is chosen for the pilot blocking system where the reverse fault carrier start function or transient block logic is required. It is set to overreach the pilot zone or opposite terminal. It is also used in conjunction with weakfeed logic. Direct tripping can be blocked or achieved via Time Delay (T3P or T3G). The forward sensing option produces time delayed backup to other devices sensing forward faults. Zone 3 is set to coordinate with adjacent terminal Zone 2 relays.

Blinder measurements (RT and RU) are available for out-of-step sensing. The inner blinder also restricts the trip zone of each of the 3-phase fault measuring units for load restriction.

Line measurement techniques applied to each zone include:

- Single-Phase-to-Ground fault detection
- Three-Phase fault detection
- Phase-to-Phase fault detection
- Phase-to-Phase-to-Ground fault detection

A unique characteristic of the MDAR system is its phase selection principle. It determines the sum of positive and negative sequence currents for each phase by a novel method which excludes the influence of pre-fault load current. From this information, the fault type can be clearly identified and a much better approximation can be obtained of the actual distance to a fault. Also by a new method requiring agreement between two measurements, the tendency toward leading-phase overreach for phase-to-phase faults is eliminated.

Single-Phase-to-Ground fault detection is accomplished by three quadrature polarized, I_0 compensated phase units ($\emptyset A$, $\emptyset B$, $\emptyset C$). Equations 1 and 2 are for operate and reference quantities respectively. The unit will produce output when the operate quantity leads the reference quantity.

$$V_{XG} - \left[I_X + \frac{Z_{0L} - Z_{1L}}{Z_{1L}} I_0 \right] Z_{CG} \quad (\text{Eq. 1})$$

$$\text{Vector}(V_Q) \quad (\text{Eq. 2})$$

where $V_{XG} = V_{AG}, V_{BG}, V_{CG}$

$I_X = I_A, I_B, I_C$

$Z_{1L}, Z_{0L} =$ positive and zero sequence line impedance

$I_0 = 1/3 (I_A + I_B + I_C)$

$Z_{CG} =$ Zone reach setting in secondary ohms.

$V_Q =$ Quadrature phase voltages, i.e., V_{CB}, V_{AC} , and V_{BA} for $\emptyset A, \emptyset B$, $\emptyset C$ units, respectively.

Three-phase fault detection is accomplished by the logic operation of one of the three ground units, plus the $3\emptyset F$ output signal from the faulted phase selector unit.

However, for a three-phase fault condition, the computation of the distance units will be:

$$V_{XG} - I_X Z_{CP} \quad (\text{Eq. 3})$$

$$\text{and } (V_Q) \quad (\text{Eq. 4})$$

where $V_{XG} = V_{AG}, V_{BG}$, or V_{CG}

$I_X = I_A, I_B$, or I_C

$Z_{CP} =$ Zone reach setting (PLTP, Z1P, Z2P, and Z3P) in secondary ohms for multi-phase faults.

$V_Q =$ Quadrature phase voltages, i.e., V_{CB}, V_{AC} , and V_{BA} for $\emptyset A, \emptyset B$ and $\emptyset C$ units, respectively.

The phase-to-phase unit responds to all phase-to-phase faults, and some single-phase-to-ground faults. Equations (5) and (6) are for operate and reference quantity, respectively. They will produce an output when the operate quantity leads the reference quantity.

$$(V_{AB} - I_{AB} Z_{CP}) \quad (\text{Eq. 5})$$

$$(V_{CB} - I_{CB} Z_{CP}) \quad (\text{Eq. 6})$$

MDAR provides high impedance ground fault detection when pilot logic is selected. A sensitive directional ground overcurrent unit supplements the pilot ground distance detection logic. It can be delayed or blocked to allow normal pilot ground operation to avoid any overtripping tendency.

Load-loss tripping entails high speed, essentially simultaneous clearing at both terminals of a transmission line for all fault types, except three-phase, without the need of a pilot channel. Any fault location on the protected circuit will be within the reach of the Zone 1 logic at one or both terminals. This causes direct tripping of the local breaker without the need of any information from the remote terminal. The remote terminal

recognizes the loss of load-current in the unfaulted phase(s), as evidence of tripping of the remote breaker. This, combined with Zone 2 distance or directional overcurrent ground fault recognition at that terminal, allows immediate tripping to take place at that terminal.

Zone 1 extension logic can be selected. In this scheme, Zone 1 assumes the Zone 2 overreach setting. Upon tripping, the reach is pulled back to a normal Zone 1 reach for 5 seconds. Use of this scheme requires the use of a high speed reclosing relay.

HARDWARE

The block diagram shows the overall arrangement of hardware in MDAR. Line voltages and currents from vt's and ct's are connected to isolating transformers, surge suppression, and anti-aliasing filters. The ac inputs are connected through a multiplexer to the analog conversion subsystem. An A/D converter places instantaneous samples of these ac signals in the microprocessor memory. Status or contact inputs are also scanned.

All relaying measurements and logic are performed by software executed in the microprocessor. The programs also handle operator interface and self-checking functions. The programs perform tripping or other control outputs through a series of contacts as shown in block diagram. The relay also includes an integral man-machine interface and a RS-232C serial port for remote communications.

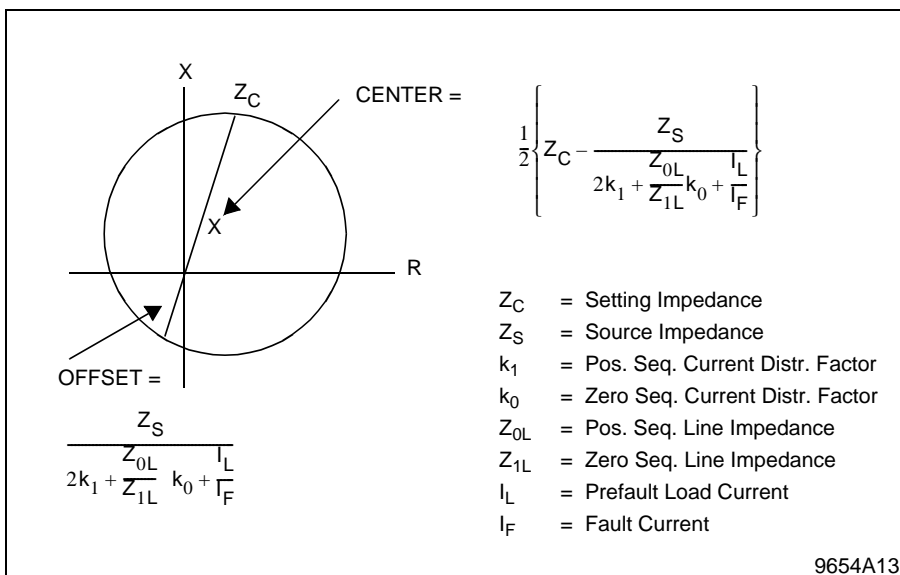

Figure 2: Single Phase-to-Ground Characteristics

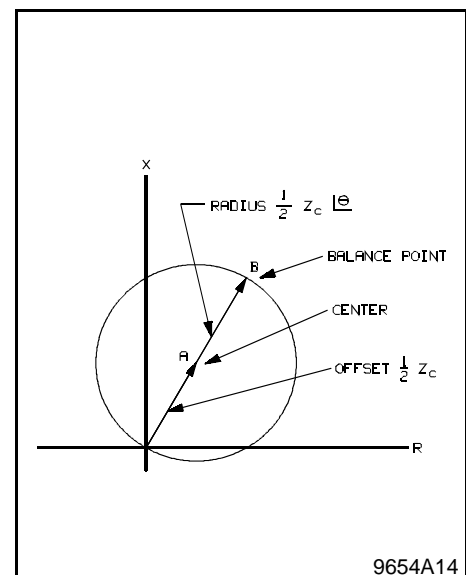

Figure 3:

DESCRIPTION OF SOFTWARE

The diagram in Figure 6 shows a simplified flow-chart for the relaying algorithms in MDAR. All algorithms are executed in a loop, as shown, which the processor repeats eight times per power cycle.

Most relaying operations are performed at all times. An important detail not shown in the flow diagram is that many of the checks are broken into small parcels, so that the whole complement of tasks is performed over a one-cycle pe-

riod eight passes through the loop. Some of the checks are done more than once each cycle.

The instantaneous sample values are converted to voltage and current phasor values using a Fourier notch-filter algorithm. An additional dc-offset correction algorithm reduces overreach errors from decaying exponential transients.

During nonfault operation, the program follows the Background Mode branch near the bottom. The processor uses its excess time to perform

hardware self checking, service the man-machine interface, and check for a disturbance in voltage or current indicating a possible fault. If a disturbance is detected, the program switches to the fault mode for several power cycles.

While operating in the fault mode, Zone 1 phase and ground measurements, pilot logic and channel control functions are executed. Fault mode operation restricts non-essential functions such as hardware self checking and servicing of the man-machine interface.

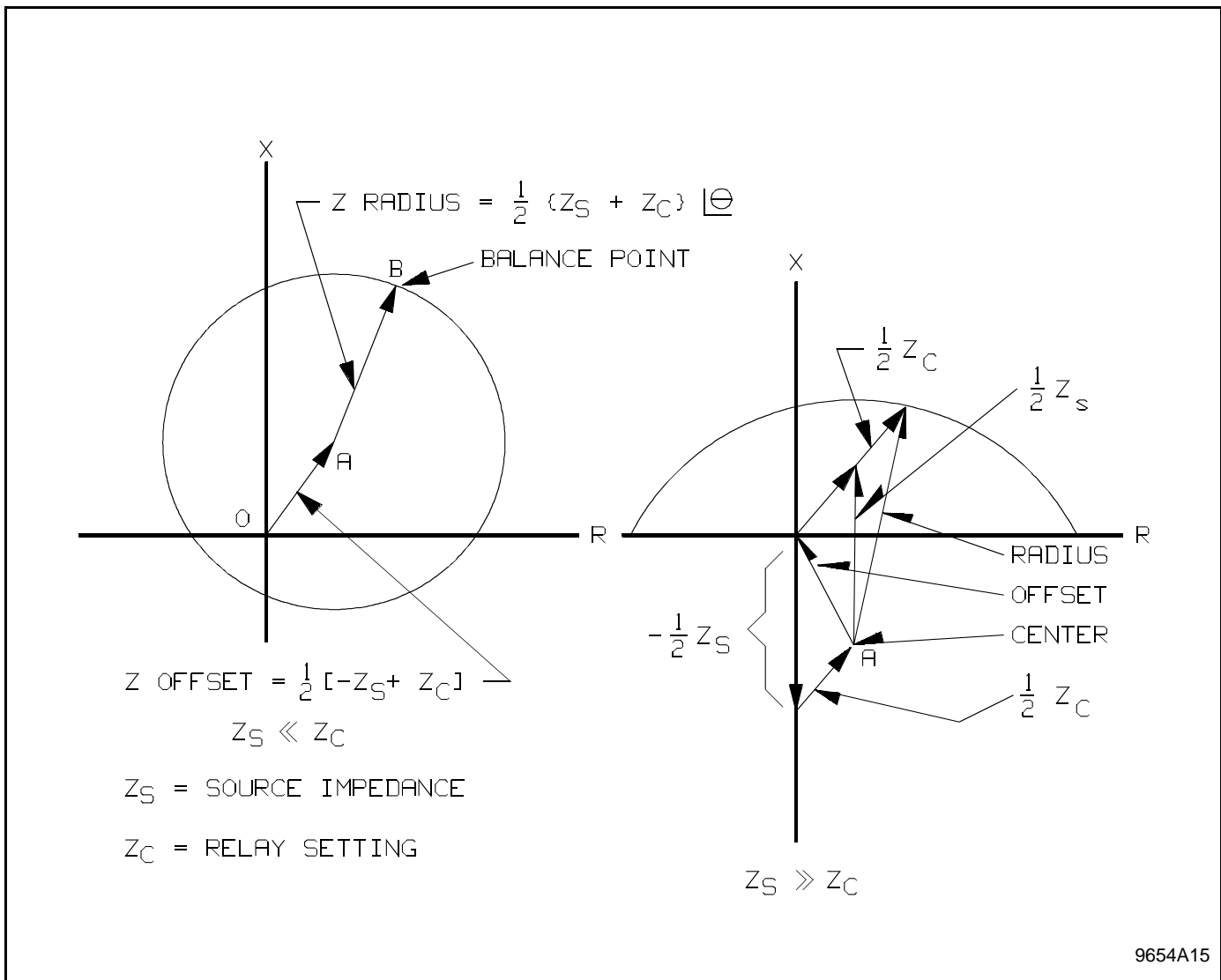

Figure 4. Mho Characteristics for Phase-to-Phase and Two Phase-to-Ground Faults (No Load Flow)

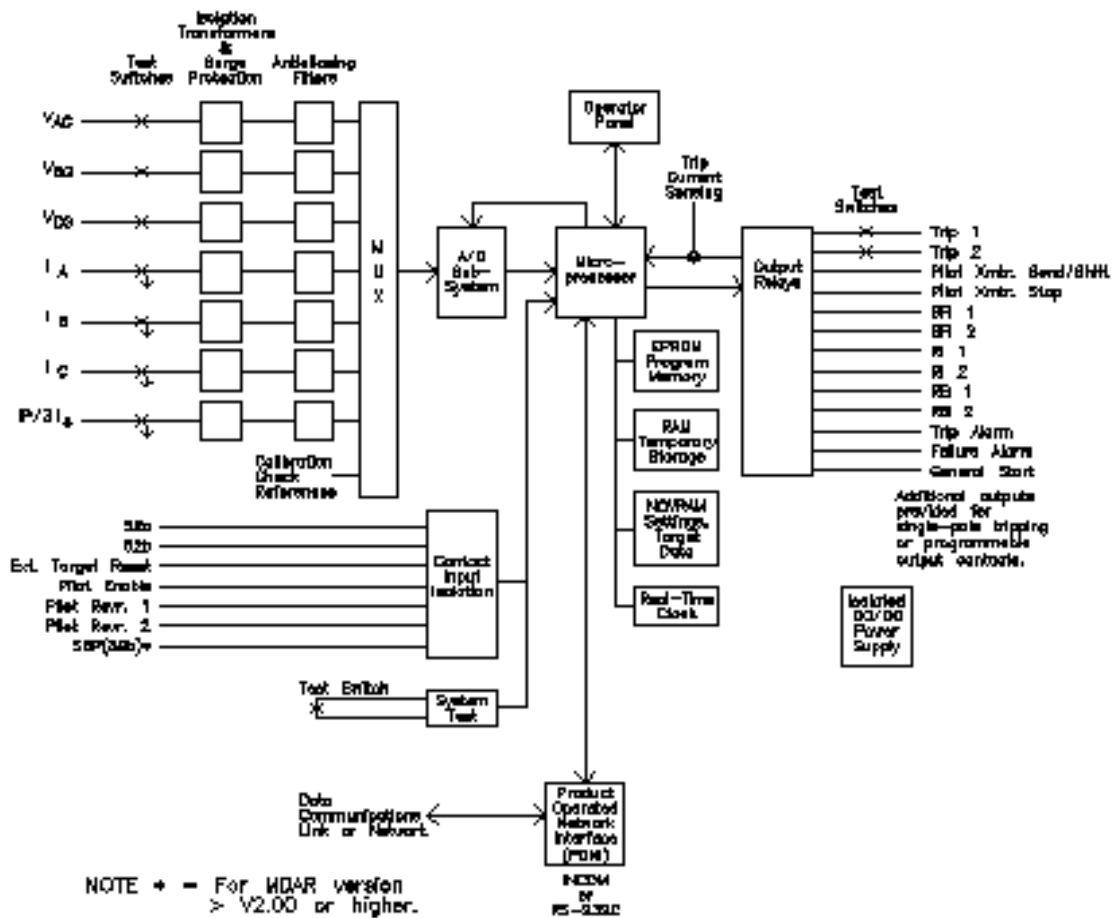

Figure 5. Simplified Block Diagram of MDAR Relay

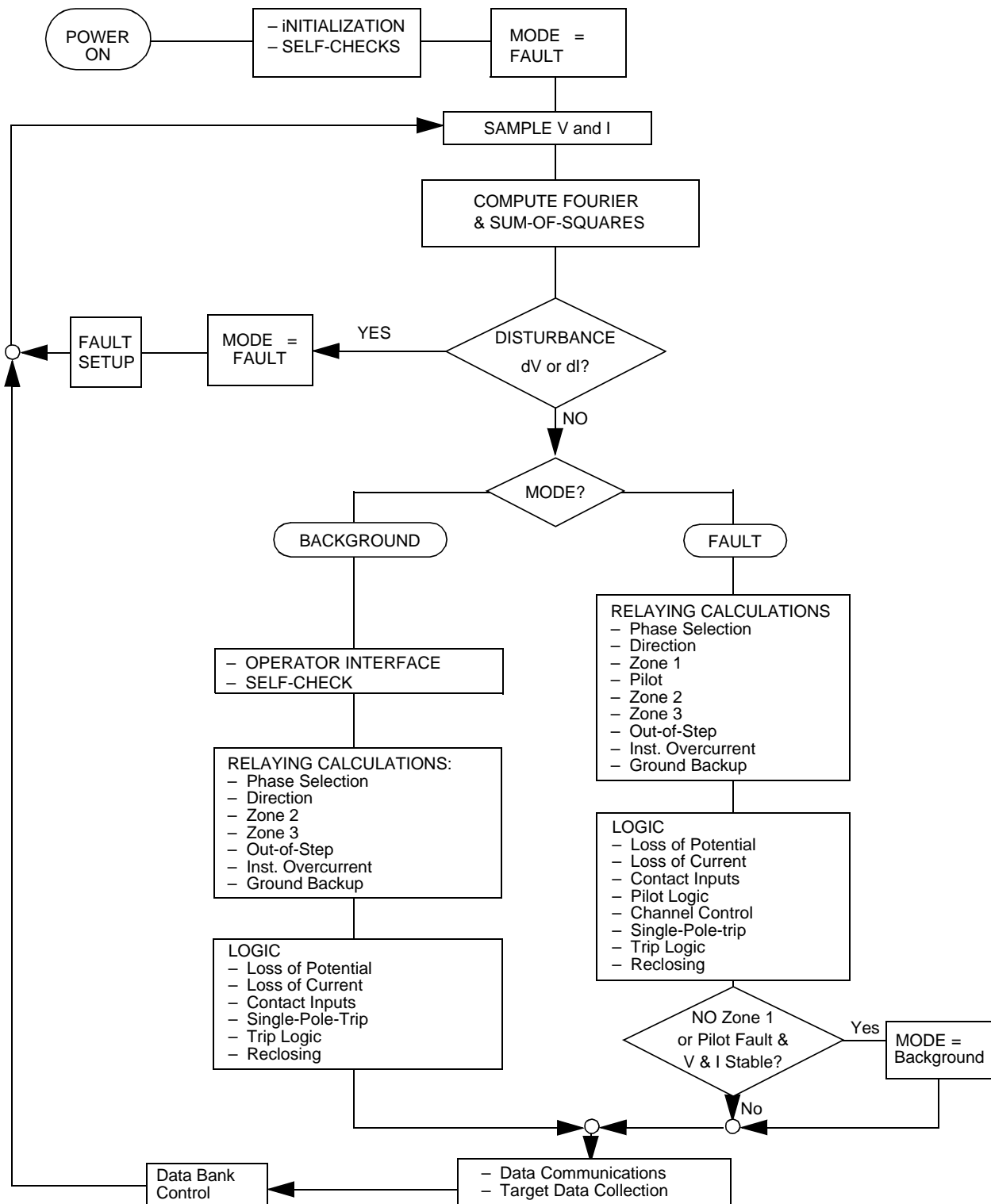

Figure 6. MDAR Relay Program Functions



Communications

ABB introduced the first intelligent family of relay communication products: WRELCOM. WRELCOM was born out of the necessity of substation devices to exchange data effectively and quickly. Through a standard phone circuit, data from modern communication-based relays and older electromechanical or solid-state relays can be obtained over the same network.

INCOM[®] (INtegrated COMmunications) defines the protocol and medium used to communicate through the network among various "INCOM[®]-based" products. The network of up to 2500 protective relays and associated devices is continually scanned by the network master device.

Network communications between protective devices is guided through the network master device which is a Basic Interface to Remote Terminal (BIRT) or an INCOM[®]-based Multi Access Controller (IMAC), which stores and organizes pertinent data, generating reports for each event. Access to this information permits intelligent decisions, such as the need to dispatch crews after a fault or relay failure.

The WRELCOM Remote Communications Program (RCP) has been written to facilitate communications with INCOM[®]-based protective relays and other network devices. It will run on any MS-DOS[®] based system. "Pull-down" menus and "Pop-up" screens are incorporated providing a user friendly man-machine interface. RCP is required to communicate with any INCOM[®] protocol relay. See I.L. 40-603 for complete details about RCP.

Functions Include:

- Relay Acknowledgment
- Relay Self-Checking Status
- Remote Settings (can be downloaded from stored files)
- Fault Record Summary
- 16 fault Records
- Metering (Voltage, Current, Phase angle, Watt Flow, Varflow, Power Factor and status of Monitoring functions)
- Intermediate Targets
- Reset Targets/LEDs
- Optional Oscillographic Data Retrieval, Listing, Plotting

Graphical Oscillographic Data display is accomplished by using the optional OSCillographic And Recording (OSCAR) software. OSCAR gives the user a method for displaying the fault information graphically, a form which is more conducive to analysis than the tabular form. OSCAR also gives the user many ways to incorporate the graphics information in hardcopy reports.

See I.L. 40-606 for complete details about OSCAR

16 Events

- 8 samples per cycle
- 1 cycle pre-trigger
- 7 cycles post-trigger
- 9 analog traces (2 ms resolution)
- 24 digital traces (2 ms resolution)

Trigger options

- Trip
- Z2 or trip
- Z2, Z3 or trip
- General start

OSCILLOGRAPHY

MDAR provides oscillographic data storage capabilities for recording system fault currents and voltages with 2 ms resolution. The information is captured with every general start and/or trip, but is only saved based on the data storing option selected. This option permits saving events for: trips only, Zone 2 initiate or trip, Zone 2 or 3 initiate or trip, or general start or trip. This allows a variable degree of system area coverage with MDAR's oscillography. Also, when the MDAR general start mode is activated longer than 7 cycles and subsequently trips, a second event second event record will be saved. The basic oscillographic functions and capabilities are shown below.

REFERENCE DOCUMENTS:

MDAR COLOR BROCHURE
MDAR RELAY SYSTEM INSTRUCTION LEAFLETS

DOCUMENT NUMBER:

B-385
I.L. 40-385.6

RCP INSTRUCTION LEAFLET
OSCAR INSTRUCTION LEAFLET

I.L. 40-603
I.L. 40-606

ACCESSORIES:

FT-14 TEST PLUG
Right Hand Plug
Left Hand Plug

STYLE NUMBER:

S# 1355D32G01
S#1355D32G02

TEST FIXTURES AND EXTENDER BOARD

Inner Chassis Test Fixture 5 A
Inner Chassis Test Fixture 1 A
Extender Board Assembly

S# 2409F39G01
S# 2409F39G02
S# 1609C55G01

SOFTWARE

Remote Communications Program (RCP)
OSCillographic And Recording (OSCAR)
COMMUNICATIONS CABLE KIT

S# SWRCP01
S# SWOSC01
S# 1504B78G01



Technical Specifications

(Pilot and Non-Pilot)

General

Operating Speed 12 milliseconds Minimum
 22 milliseconds Typical

AC Voltage Input V_{LL} @ 60 Hz 120 V_{rms}
 V_{LN} 70 V_{rms}
 V_{LL} @ 50 Hz 110 V_{rms}
 V_{LN} 63.5 V_{rms}

AC Current Input In 1 or 5 A

Maximum Permissible ac Voltage

Continuous 1.5 x Nominal
 10 Seconds 2.5 x Nominal

Maximum Permissible ac Current

Continuous 3 x In
 1 Second 100 x In

Minimum Operating Current 0.1 x In

Rated Frequency 50 or 60 Hz

DC Battery Voltages

<u>Nominal</u>	<u>Operating Range</u>
48/60 Vdc	38-70 Vdc
110/125 Vdc	88-145 Vdc
220/250 Vdc	176-290 Vdc

Burdens

dc Battery 7 Watts Normal
 30 Watts Tripping
 Voltage 0.02 VA/Phase at 70 Vac
 Current 0.15 VA/Phase at 5 A

External Connections

- Terminal blocks located on the rear of the chassis suitable for #14 square torque lugs
- Wiring to FT-14 switches suitable for #12 wire lugs

Dimensions & Weight

- (4RU) 7.0" high (177.8mm)
- Standard 19" rack 19.0" wide (482.6mm)
- 14" deep (356mm) Including terminal blocks
- 35 pounds (16 kg net)

Contact Data

- Two Breaker Trip Contacts*
- Two Breaker Failure Initiate Contacts**
- Two Reclose Initiate Contacts**
- One General Start Contact (Indicates Power System Disturbance)**
- One System Failure Alarm Contact**
- Two Trip Alarm Contacts**
- Eight Programmable Output Contacts (Optional):
 Four NO Trip Rated With FT-Switch Isolation*
 Four NO/NC (Jumper Selectable) Contacts**
- Six Single Pole Trip Contacts (Optional)*

***Trip Contacts**

- Make and carry 30 A for 1 second, 10 A continuous capability. Break 50 watts resistive or 25 watts

with L/R -.045 seconds

****Non-Trip Contacts**

- 1 A Continuous
- 0.1 A Resistive Interrupt Capability
- Supports 1000 Vac across open contacts

Ambient Temperature Range

For Operation -20°C to +60°C
 For Storage -40°C to +80°C

Insulation Test Voltage

- 2.8k Vdc, 1 minute (ANSI C37.90) (IEC-255-6)

Impulse Voltage Withstand

- 5k V Peak, 1.2x50 ms 0.5 Joule, (IEC-255-5)

Surge Withstand Voltage

- 2.5k V, 1 MHz (ANSI C37.90.1, IEC-255-6)

Fast Transient Voltage

- 4k V, 5x50 ms (IEC 801-4);
- 5k V, 10x150 ms (ANSI C37.90.1)

EMI Volts/Meter Withstand

- 25 MHz-1GHz, 10V/m Withstand (ANSI C37.90.2)

Standards:

ANSI C37.90 IEC-255-16
 IEC-255-6A BS142-1982
 IEC-255-12

Measurements

Number of Zones
 • 3 zones are standard; optional pilot adds additional zone; 3rd zone reversible

Equivalent Measurement Units

- Three variable mho phase-to-ground and one variable mho phase-to-phase impedance unit per zone.
- One three phase unit consisting of any one variable mho phase-to-ground unit operation plus a three phase fault output from the Faulted Phase Selector
- Three phase and one ground directional high set overcurrent units.
- Three phase non-directional overcurrent units for load loss trip and close-into-fault trip.
- Three phase non-directional medium set overcurrent units for phase distance supervision.
- One ground medium set non-directional overcurrent unit for ground distance supervision.
- One ground overcurrent unit for loss of current monitoring.
- One inverse time overcurrent ground unit with selectable directional or non-directional capability.
- One forward set instantaneous directional overcurrent ground unit. (Pilot logic high-resistance ground fault protection.)
- Three undervoltage units for weakfeed and loss of potential supervision.
- Three voltage change (ΔV) fault detectors.
- Four current change (ΔI) fault detectors.
- One instantaneous overcurrent unit low set.
- One reverse set instantaneous directional overcurrent ground unit (pilot carrier start, weakfeed, transient block).

Optional Single-Pole-Trip Logic and Outputs

- Single Pole Trip/Single Pole Reclose Initiate on first fault
- 3 Pole Trip/Reclose Block if reclosing on a permanent fault
- 3 Pole Trip/Reclose Block if second fault occurs during single phasing
- 3 Pole Trip on a selectable time delay limit if the system fails to reclose

Setting Ranges

CT ratio: 30-5000:1
 VT ratio: 100-7000:1

Phase & Ground Distance

Z1, Z2, Z3, Pilot Option

- 0.01-50 ohms in 0.01 ohm steps for 5 A ct
- 0.05-250 ohms in 0.05 ohm steps for 1 A ct

Zone Timers:

Independent timers for phase and ground.

Zone 1

Selectable on 2 cycles in Ver. 2.xx

Zone 2

0.1 to 2.9 seconds in 0.01 second steps

Zone 3

0.1 to 9.99 seconds in 0.01 second steps

Ohms per unit distance

0.300-1.500 in 0.001/DTYP (Km or Mi)

Inverse Time Overcurrent Ground

- Pickup 0.5-4.0 in 0.5 A increments for 5 A ct
- Pickup 0.1-0.8 in 0.1 A increments for 1 A ct
- Choice of 10 time curves
- Set for directional or non-directional operation

High set instantaneous overcurrent trip units - phase and ground.

- 2.0-150 in 0.5 A steps for 5 A ct
- 0.4-30 in 0.1A steps for 1 A ct

Mediumset and Lowset instantaneous overcurrent trip units -phase and ground

- 0.5-10 in 0.5 A steps for 5 A ct
- 0.1-2 in 0.1A steps for 1 A ct

Load Loss Current Units (I_{AL} , I_{BL} , I_{CL})

- 0.5-10 in 0.5 A steps for 5 A ct
- 0.1-2 in 0.1 A steps for 1 A ct

Out-of-Step Block

- OSB Override Timer
 400-4000 milliseconds in 16 millisecond steps
- OSB Inner Blinder
 1.0-15.0 ohms in 0.1 ohm steps
- OSB Inner Blinder
 3.0-15.0 ohms in 0.1 ohm steps

Positive/Zero Sequence Impedance Characteristic Angles

- 40 to 90 in 1.0 degree steps

Zero Sequence Compensation (ZOL/Z1)

- 0.1-7.0 in 0.1 steps

Single Phasing Limit Timer

- 300-5000 milliseconds in 50 millisecond steps

Time and Date

- Year, month, weekday, date, hour, minute

Blocking System Channel Coordination Timer

- 0-32 ms in 2 ms steps

Additional Settings

Pilot System Logic Selection

- 3 Zone Non-Pilot
- Zone 1 Extension
- POTT
- Unblock
- Block

Weakfeed Enable

Yes or No

Close Into Fault Trip

Stub Bus, Close Into Fault With Time Delay, Close into Fault or No

Load Loss Trip

Yes or No

Loss Of Potential Block

Distance Trip Only, All Trips or No



REL 300 CATALOG NUMBERING SYSTEM

**REL 300 NUMERICAL
 RELAY SYSTEM (50/60 HZ)**

TRIP

Three Pole Trip
 Single Pole Trip
 Three Pole Trip w/Programmable Contacts *

CURRENT INPUT

1A
 5A

BATTERY SUPPLY VOLTAGE

48/60 Vdc
 110/125 Vdc
 220/250 Vdc

POWER SWING BLOCK

Power Swing Block

PILOT SYSTEM/CHANNEL INTERFACE

Pilot System-Channel Interface
 Non-Pilot System, No Channel Interface

TEST SWITCHES

FT-14 Switches
 No FT-14 Switches

COMMUNICATION DEVICE

RS-232C
 RS-232C (with IRIG - B port)
 INCOM

**SOFTWARE OPTION
 (Oscillographic Data Storage STD)****

Version 2.0X
 Version 2.1X
 Version 2.2X

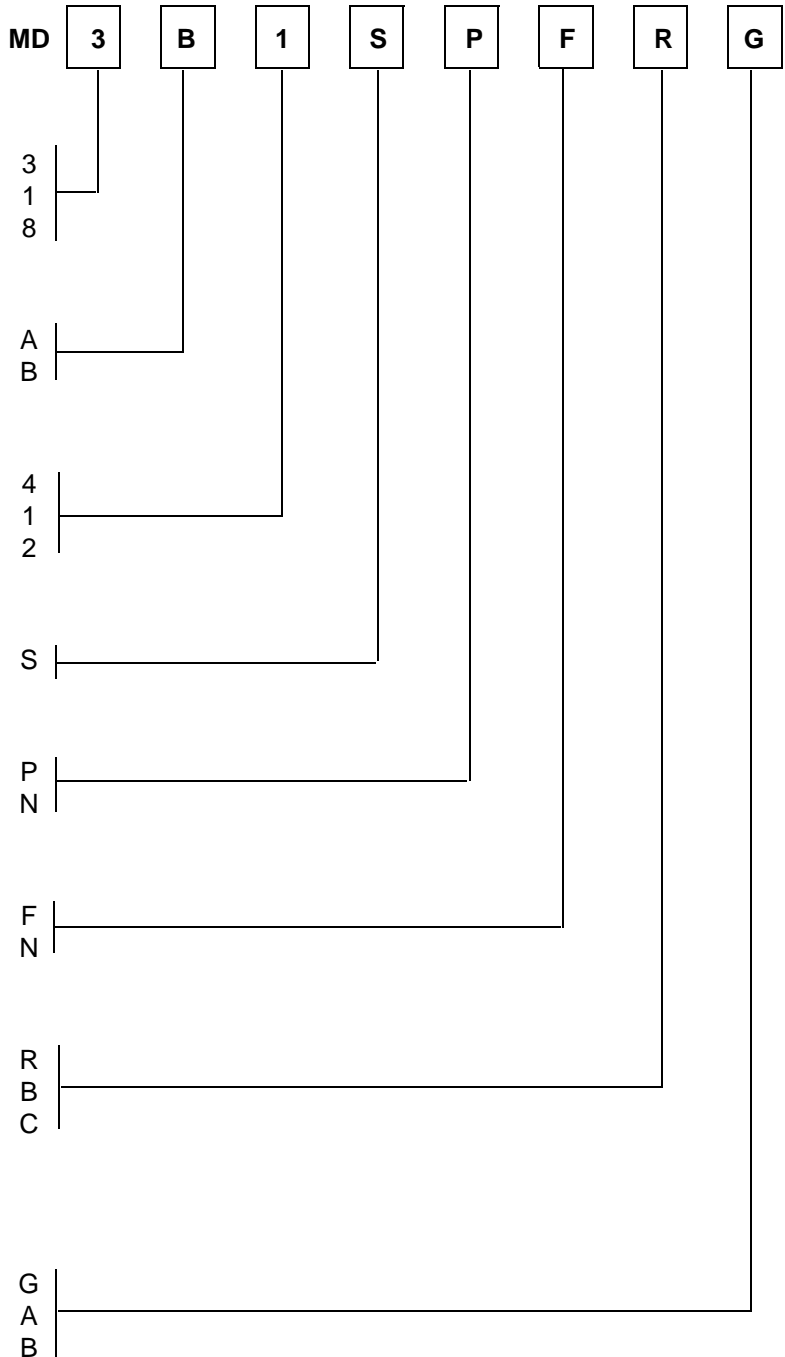

ABB Power T&D Company Inc.
 Relay Division
 4300 Coral Ridge Drive
 Coral Springs, FL 33065
 954-752-6700

V

ABB Power T&D Company Inc.
 Relay Division
 7036 Snowdrift Road, Suite 2
 Allentown, PA 18106
 610-395-7333