

# Line Differential Protection and Control RED615 Relion® 615 series

RED615 is a phase-segregated, two-end, line differential protection and control IED perfectly harmonized for utility and industrial power systems, including looped and meshed distribution networks with or without decentralized power generation. RED615 is a member of ABB's Relion® product family and a part of its 615 protection and control product series. The 615 series IEDs are characterized by their compactness and withdrawable design. Re-engineered from the ground up, the 615 series has been designed to unleash the full potential of the IEC 61850 standard for communication and interoperability of substation automation equipment.

## Application

RED615 provides phase-segregated high-speed, longitudinal differential protection for overhead line and cable feeders in utility and industry distribution networks. Three standard RED615 configurations are available, a pure line-differential protection configuration and two extended configurations with additional protection functions. Two RED615s interconnected over a communication link form an absolutely selective unit protection scheme. Protection of ring-type and meshed distribution networks generally requires unit protection solutions, also applied in radial networks containing distributed power generation.

## Protection and control

RED615 features two-stage, phase-segregated line differential protection, four-stage phase overcurrent protection, two-stage phase unbalance and loss-of-phase protection, and circuit-breaker failure protection. Further, RED615 incorporates a lockout relay and a second harmonic restraint function to identify inrush current conditions. Depending on the standard configuration chosen, the basic functionality can be extended by thermal overload protection, directional or non-directional earth-fault protection, sensitive earth-fault protection, phase



discontinuity protection, transient/intermittent earth-fault protection and three-pole multi-shot auto-reclose functions for overhead line feeders.

Besides protection RED615 also offers the functionality needed for control of one circuit breaker. To protect the IED from unauthorized access and to maintain the integrity of information, the IED has been provided with a four-level, role-based user authentication system.

## Binary signal transfer

Binary signal transfer (BST) can be used for carrying blocking and intertrip signals as well as status and position information between the local and remote end of the line. The BST functionality comprises eight binary signals, which are carried between the substations inside protection telegrams transferred over the communication link. The transfer of BST signals goes in both directions and the signal transfer time is extremely short, in the order of a few milliseconds. BST signalling and the logics of RED615 enable adaptive protection and control schemes to be engineered to create tomorrow's smart power systems.

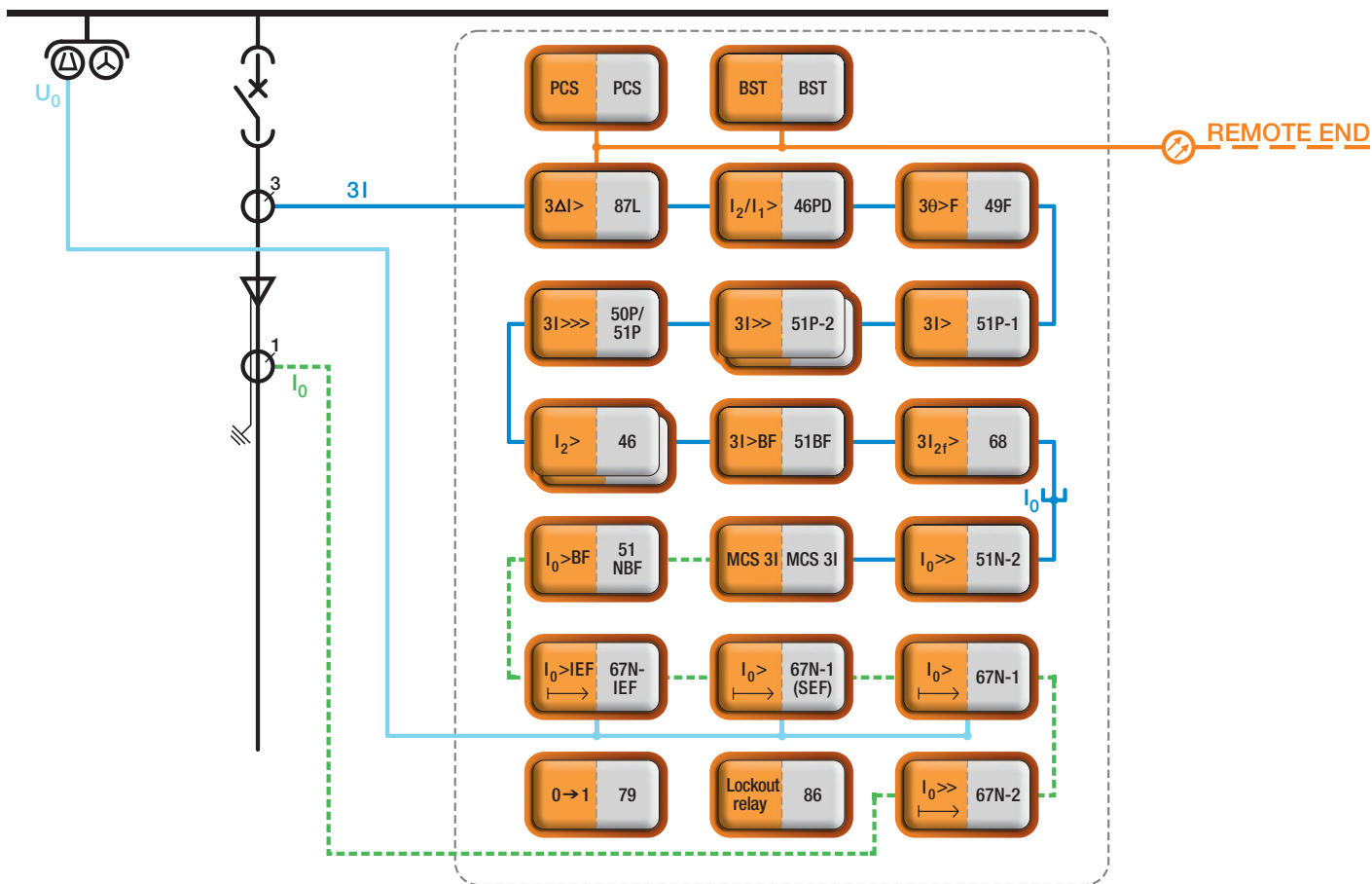

Protection function overview of RED615.

### Standardized communication

RED615 features native support for the new IEC 61850 standard for communication in substations. The IED also supports the industry standard Modbus® protocol, and the well-established DNP3 and IEC 60870-5-103 protocols.

The in-depth implementation of the IEC 61850 substation communication standard in RED615 also includes peer-to-peer communication over a substation-wide Ethernet LAN using the GOOSE-services defined by the standard.

### Protection communication supervision

The communication channel between either end of the protected line is constantly supervised. Should the communication channel be interrupted or suffer interference the fast-acting line differential protection functions will be blocked immediately. The automatic restraint affects all functions which rely on the continuous availability of the protection communication channel. The channel supervision includes recognition of missing or delayed telegrams carrying analog measurement values or binary information. The reset delay is user-selectable.

### Pre-emptive condition monitoring

To secure the operational availability of the protection, RED615 incorporates a range of monitoring and watchdog functions to supervise the hardware and software, the

communication system, the circuit-breaker trip circuit and the CTs. CT faults may cause undesired operation of the line differential protection and the phase unbalance protection. Hence, a fast-acting CT supervision system immediately blocks the operation of the line differential protection function and the phase unbalance protection function on detection of any CT signal anomaly. Depending on the chosen device configuration, the IED monitors the wear and tear of the circuit breaker, the spring charging time of the CB operating mechanism and the gas pressure of the breaker chambers. The IED also supervises the breaker travel time and the number of CB operations to provide basic information for scheduling CB maintenance.

### For more information see RED615 Product Guide.

For more information please contact:

#### ABB Oy, Distribution Automation

P.O. Box 699  
FI-65101 VAASA, Finland  
Phone: +358 10 22 11  
Fax: +358 10 22 41094

[www.abb.com/substationautomation](http://www.abb.com/substationautomation)