

Relion®

Power system protection and automation reference

Reducing substation wiring costs with IEC 61850

Reducing substation wiring costs with IEC 61850 GOOSE for earth-fault protection management under varying network operating states

ORES (Ltd) is a Belgian electricity and gas distribution grids operator in the Walloon region in southern Belgium. In the city of Liège a large project started in 2007 with the aim to revitalize the city neighborhood by creating an attractive urban centre. In the heart of the project was an exceptional architectural building that would become more than a shopping mall. To secure the distribution of electricity to the building and the 6 kV power distribution network a new switching substation was built, including ABB's Relion® 615 series IEDs. The decision to use IEC 61850 compliant substation automation IEDs paved the way to a simplified and cost efficient substation wiring contributing, an orientation towards future technologies, interoperability between products and applications, to enhance the overall substation management efficiency.

ORES is the company name of the electricity and gas distribution grids operator owned by eight regional electricity distributors in Wallonia, i.e. Ideg, IEH, IGH, Interost, Interlux, Interomosane, Sedilec and Simogel. ORES supplies some 1.4 million customers with a total of around 12 TWh of electricity a year. Currently ORES employs about 2,300 persons. The new multi-functional complex of Médiacité is situated in Longdoz in the city of Liège. Médiacité combines commerce, leisure, culture and media, and is expected to draw up to 7 million visitors a year with its 58,000 m² of shopping area, cinemas and related services.

Médiacité shopping and entertainment centre at Liège, Belgium. © Copyright G. De Kinder. Médiacité is a conception and a development made by Wilhelm & Co Group, Belgium.  Wilhelm & Co



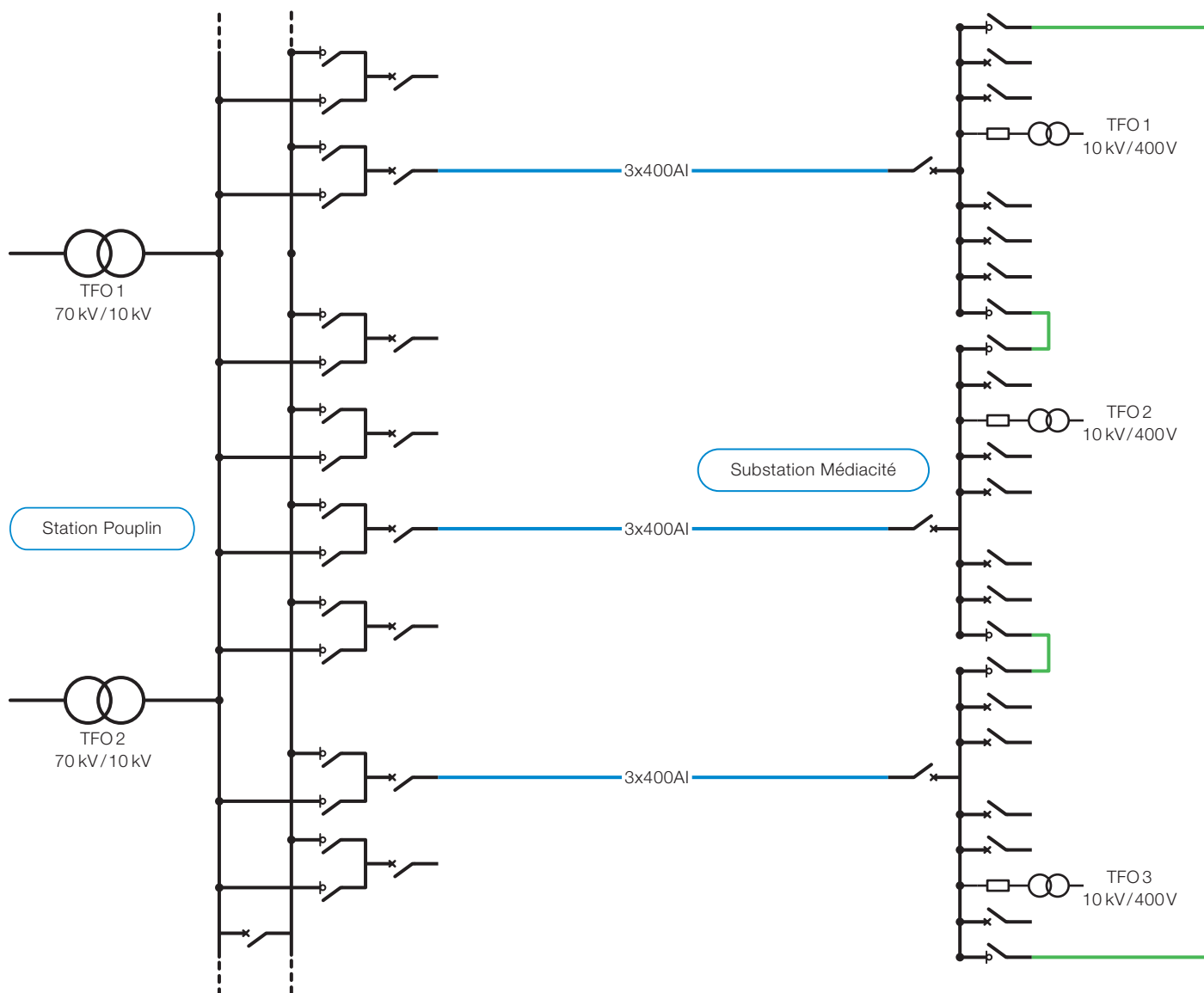

The secured power system of the Médiacité shopping and entertainment centre at Liège, Belgium. The selected power system layout focuses on maximum reliability and availability of the power supply.

Power distribution in Médiacité

The new 10 kV switching substation in the heart of Médiacité is supplied by the 70/10 kV substation of Pouplin. The Pouplin substation, provided with a double busbar system, is fed from two 70/10 kV power transformers. The supply of the Médiacité substation is secured by means of three parallel 10 kV cable feeders from the Pouplin substation. These cable feeders can be connected to either one of the two busbars at Pouplin. At Médiacité the three feeder cables supply their dedicated sections of the switchgear. Besides the new Médiacité shopping and entertainment center and the 6 kV city network the switching substation also supplies an important radio station, the supply of which is secured by multiple distribution transformers. The dedicated busbar sections can be interconnected to form a ring, which enables a secured supply from another feeder cable. Mr **Frederic de Wouters de Bouchout**, SCADA System, Remote Control and Protection Manager of ORES points out that the Walloon radio station at Médiacité is an important public service institution for the local people. The supply of the radio station must be maintained under any power system disturbance situation.

The Médiacité substation includes ABB's air insulated Uniswitch switchgear well suited for applications like shopping centres and large buildings. Furthermore, the substation incorporates the novel IEC 61850 compliant Relion® 615 series Feeder Protection and Control IEDs. The REF615 IEDs are applied for the protection and control of the three incoming feeders and their circuit breakers and the 17 outgoing feeders. In addition REF615 IEDs have been installed for protection and control purposes in the bus coupler bays.

The function of the data communication network has been secured according to the same principles as the power system network. To assure a reliable operation the networks have been designed to a uniform entity, expressing the same implementation principles throughout the application, from the primary circuit to the data communication solution. Ethernet switches are interconnected in a fibre optic loop to ensure redundancy. All other connections (protection IED to switch, switch to RTU) are carried out with a single SFTP data cable. The signals are transferred to the remote terminal unit RTU560 using the IEC 61850 protocol. The communication

between the RTU560 units and the network control centre utilizes the IEC 60870-5-104 communication protocol.

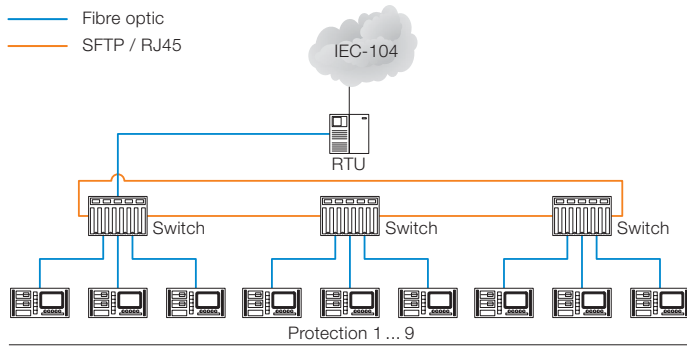

IEC 61850 LAN topology of the substation supplying Mediacité shopping and entertainment centre. CIRED 2009 Paper 0372.

IEC 61850, the substation automation standard of choice for ORES

ORES has made the decision to implement the IEC 61850 standard in all new large medium voltage distribution substations. This is a result of ORES' interest in new technology and the company's orientation towards long-term stability and less dependencies of proprietary protocols. "The reason for us to invest in IEC 61850 compliant technology is the promise to decrease dependency of proprietary standards. In all new big green field projects we will implement the IEC 61850 standard. According to ORES' investment plan for this year we have 5 to 6 new substations, which are built according to the IEC 61850 standard. As we see it at the moment, we will invest in 5 to 7 new

substations next year based on IEC 61850 compliant technology," states Mr Frederic de Wouters de Bouchout.

In Médiacité the GOOSE messaging is used for earth-fault adaptation. The protection system is adapted to the varying operating states of the network. Using GOOSE messaging the protection system is informed about changes in the network operating stage. For instance, when network changes are implemented using single-phase interruptors the unintentional operation of the earth-fault protection system is prevented by momentarily desensitizing the earth-fault protection system.

By utilizing GOOSE messaging between the IEDs, the peer-to-peer communication is inherently supervised. This will prevent the situation that the connection to an IED has been lost without the operator being aware of it. Although hardwired communication solutions have been extensively utilized throughout the field, a satisfactory supervision of the communication channels has been hard to achieve. This is where the inherent communication supervision of the IEC 61850 based GOOSE service offers a significant advantage over earlier solutions. Using GOOSE the communication supervision is a natural and integral part of the communication and using GOOSE system enhancements are easier to accomplish than with hardwired solutions.

Tangible wiring cost reductions using modern IEC 61850 technology

The IEC 61850 standard offers a range of features and benefits for protection and control applications, among them peer-to-peer communication using GOOSE. Apart from enabling fast and supervised communication, the use of

The 615 series IEDs were installed in ABB's Uniswitch switchgear.





Serge Marée and Frederic de Wouters de Bouchout of ORES.

GOOSE also enables simplified substation wiring. In practice only one Ethernet cable is required between the IEDs of a substation and an Ethernet switch to enable communication between the protection and control IEDs. This can be compared with a hardwired solution where, for each signal, a copper wire is connected from each IED to all the other IEDs in the substation. Frederic de Wouters de Bouchout noticed: "We believe that the IEC 61850 is the future standard. All the protection relay manufacturers are developing their range of IEC 61850 compliant products. The IEC 61850 technology offers a cost-efficient solution by reducing the need for hardwiring between the switchgear bays. The system flexibility in terms of expandability is a key benefit of the IEC 61850 compliant system."

According to calculations made by ORES, substantial wiring cost reductions were achieved at the Médiacité substation due to the simplified wiring enabled by the IEC 61850 based solution. IEC 61850 is a future-proof standard, which promises longevity and interoperability between devices and applications and which relies on well established Ethernet networking technology.

In addition to the reduced installation cost due to the simplified wiring, the use of the IEC 61850 standard offers flexibility and easy expandability, if the switchgear needs to be extended or modified. Signal modifications can be done without changing the wiring between the IEDs and interlocking schemes between the cubicles in existing switchgear can be added without touching the wiring. Less wiring means reduced time spent on substation engineering and commissioning.

Investment comparison between an IEC 61850 based and a traditional hardwired substation. As can be seen from the following table new technology must not necessarily be more expensive than traditional technology. CIRED 2009 Paper 0372.

Project:	IEC-104 & IEC 61850	TG80x & Protection relays without communication capability
RTU + protection	49,700.00 €	56,300.00 €
LAN (switches, wiring, ...)	7,000.00 €	0,00 €
Wiring	4,950.00 €	12,360.00 €
TOTAL	61,650.00 €	68,660.00 €
	100.00%	111.40%

Cooperation for implementation of new power system technology

Médiacité is the first IEC 61850 compliant substation installed and commissioned by ORES. When new technology is taken into use for the first time a seamless cooperation between the technology supplier and the substation operator is of particular importance. "After the first successful IEC 61850 project carried out by ORES and ABB Belgium in cooperation, the following projects will be much easier accomplish," says Mr **Serge Marée**, Remote Control and Protection Southeast Foreman of ORES.

Contact us

ABB Oy, Distribution Automation

P.O. Box 699

FI-65101 VAASA, Finland

Phone: +358 10 22 11

Fax: +358 10 22 41094

www.abb.com/substationautomation