

SPA-ZC 302

Profibus-DPV1/SPA Gateway

Installation and Commissioning Manual



1. About this manual	7
1.1. Copyrights	7
1.2. Trademarks	7
1.3. General	7
1.4. Use of symbols	7
1.5. Terminology	8
1.6. Abbreviations	8
1.7. Related documents	9
1.8. Document revisions	9
1.9. Safety information	9
2. Introduction	11
2.1. Features	11
2.2. Module parts	12
2.3. Ordering information	12
2.4. Additional support products	13
2.5. Backwards compatibility	13
3. Installation	15
3.1. Application	15
3.2. Mechanical installation	16
3.3. Electrical installation	16
3.3.1. Auxiliary power connection	16
3.3.2. Profibus DP version 1 bus interface	16
3.3.2.1. RS-485/Profibus DP version 1	16
3.3.2.2. Address selectors	17
3.3.2.3. Profibus DP communication speeds	18
3.3.3. SPA bus/configuration interface	18
3.3.3.1. Communication settings	18
3.3.3.2. SPA bus communication speeds	19
3.3.3.3. DIP switch configuration	19
3.3.3.4. RS-485/SPA bus cable	22
3.3.3.5. RS-485/SPA bus cable	22
3.3.3.6. TTL/SPA bus cable	23
3.3.3.7. RS-232/SPA bus cable	23
3.3.3.8. SPA loop	24
3.3.3.9. Configuration cable	24
3.4. Installing Profibus-DPV1/SPA Configuration Tool	24
3.4.1. System requirements	24
3.4.2. Installing the software	24
3.4.3. Uninstalling the software	25

4. Commissioning	27
4.1. Hardware set-up	27
4.2. New configuration	28
4.3. Multislave configuration	30
4.4. Downloading configurations	31
4.5. Gateway initialization	33
4.6. Time synchronization	33
4.7. In Use flags	34
5. Profibus-DPV1/SPA Gateway Configuration Tool	35
5.1. Program overview	35
5.2. Starting PCT	35
5.3. Main view	36
5.4. PCT menus	36
5.4.1. File menu	37
5.4.1.1. Open	37
5.4.1.2. Print	37
5.4.1.3. Save / Save As	37
5.4.1.4. Exit	37
5.4.1.5. Export csv	37
5.4.2. Device menu	37
5.4.2.1. Download/upload configuration (as)	38
5.4.2.2. Download/upload archive	38
5.4.2.3. Upload diagnostics	38
5.4.2.4. Clear diagnostics	38
5.4.2.5. Get firmware version	39
5.4.3. Settings	39
5.4.4. Slave menu	39
5.4.5. View	40
5.4.5.1. Refresh	40
5.4.6. Help	40
5.4.7. Configuration options	40
5.4.7.1. SPA configuration	40
5.4.7.2. Profibus configuration	41
5.4.8. Template info	42
5.4.8.1. Analog input	42
5.4.8.2. Digital input	43
5.4.8.3. Digital input, packed data type	46
5.4.8.4. Analog output	46
5.4.8.5. Digital output	47
5.4.8.6. Indirect SPA Messages	48
5.4.8.7. Scaling of messages	49
5.4.9. Message priority	50

6. Standard configuration templates	51
6.1. Module status word	51
6.2. Slave status word	52
6.3. Usage and purpose of SPA protocol events	52
6.4. Using indirect SPA messages	53
6.5. GSD file	55
6.5.1. GSD file and standard configurations	55
6.5.2. Using GSD file	55
6.6. Standard configuration templates	56
7. Technical data	57
7.1. Interfaces	57
7.2. Power supply	57
8. Maintenance and service	61
8.1. General about service	61
8.2. Custom configurations	61
8.2.1. Limitations	61
8.3. Self-diagnosis	62
8.3.1. LED indicators	62
8.4. Troubleshooting	63
8.4.1. Gateway diagnostics	63
8.4.2. Communication errors between SPA-ZC 302 and SPA slave	66

1. About this manual

1.1. Copyrights

The information in this document is subject to change without notice and should not be construed as a commitment by ABB Oy. ABB Oy assumes no responsibility for any errors that may appear in this document.

In no event shall ABB Oy be liable for direct, indirect, special, incidental or consequential damages of any nature or kind arising from the use of this document, nor shall ABB Oy be liable for incidental or consequential damages arising from use of any software or hardware described in this document.

This document and parts thereof must not be reproduced or copied without written permission from ABB Oy, and the contents thereof must not be imparted to a third party nor used for any unauthorized purpose.

The software or hardware described in this document is furnished under a license and may be used, copied, or disclosed only in accordance with the terms of such license.

Copyright © 2008 ABB Oy
All rights reserved.

1.2. Trademarks

ABB is a registered trademark of ABB Group. All other brand or product names mentioned in this document may be trademarks or registered trademarks of their respective holders.

1.3. General

This manual provides thorough information on SPA-ZC 302, which is an interface module for SPA bus protection relays providing connectivity to the Profibus DP fieldbus.

1.4. Use of symbols

This publication includes warning, caution, and information icons that point out safety related conditions or other important information. It also includes tip icons to point out useful information to the reader. The corresponding icons should be interpreted as follows:



The warning icon indicates the presence of a hazard which could result in personal injury.



The caution icon indicates important information or warning related to the concept discussed in the text. It might indicate the presence of a hazard which could result in corruption of software or damage to equipment or property.



The information icon alerts the reader to relevant facts and conditions.

Although warning hazards are related to personal injury, and caution hazards are associated with equipment or property damage, it should be understood that operation of damaged equipment could, under certain operational conditions, result in degraded process performance leading to personal injury or death. Therefore, comply fully with all warning and caution notices.

1.5. Terminology

The following is a list of terms associated with SPA-ZC302 that you should be familiar with. The list contains terms that are unique to ABB or have a usage or definition that is different from standard industry usage.

Term	Description
PCT	Profibus DP/SPA Gateway Configuration Tool
SPA	Data communication protocol developed by ABB
SPACOM	ABB product family

1.6. Abbreviations

ABS	AnyBus
ASIC	Application specific integrated circuit
Ch/Cat/Dno	SPA message format: Channel, category, data number
FCh/LCh/Cat/FDno/LDno	SPA message format: First channel, last channel, first data number, last data number
COM	Component object model
CRC	Cyclical redundancy code
DIP	Dual inline pin
DP	Data processing
GND	Ground
GSD	Geräte Stamm Datei, basic Profibus device
LED	Light-emitting diode
LSB	Least significant byte
I/O	Input/output
MSB	Most significant byte

Installation and Commissioning Manual

N/C	Not connected
NACK	Negative acknowledgement
RTD	Resistance temperature detector
SRAM	Static random access memory
TTL	Transistor-transistor logic
USB	Universal serial bus



1.7. Related documents

Name of the manual	MRS number
Standard Configuration Templates	1MRS755177
SPA-ZC 302 configuration CD	1MRS752534-MCD

1.8. Document revisions

Version	Revision number	Date	History
A	1.03.03	14.11.2003	Document created
B	2.0	16.05.2005	-Multislave support added -Packed SPA binary read support
C	2.0	16.05.2008	-Ordering information updated

1.9. Safety information

	Dangerous voltages can occur on the connectors, even though the auxiliary voltage has been disconnected.
	National and local electrical safety regulations must always be followed.
	The device contains components which are sensitive to electrostatic discharge. Unnecessary touching of electronic components must therefore be avoided.
	The frame of the device has to be carefully earthed.
	Only a competent electrician is allowed to carry out the electrical installation.
	Non-observance can result in death, personal injury or substantial property damage.
	Breaking the sealing tape on the upper handle of the device will result in loss of warranty and proper operation will no longer be guaranteed.
	Do not touch the inside of the case. The adapter case internals may contain high voltage potential and touching these may cause personal injury.

2. Introduction

The SPA-ZC 302 is an interface module for SPA bus protection relays, that provides connectivity to the Profibus DP fieldbus. The Profibus DP specification and the structure of its messages are defined in the European standard EN50170. The SPA-ZC 302 is referred to as gateway hereinafter in this document.

The mechanical and electrical connection of the gateway to relays with SPA bus interface is described in Chapter 3. Installation. Gateway programming is described in Chapter 4. Commissioning.

As a prerequisite, you should understand the communication properties of the protection relays that is to be connected to the gateway. This information is available in the manual for the protection relay in question. It is also necessary to have basic understanding of the Profibus DP master system that is going to be connected to the gateway.

2.1. Features

- Profibus DP Version 1 connectivity for devices with SPA bus interface
- Internal power supply
- Support of SPA bus interface with RS-485, RS-232 or TTL levels
- Easy-to-use configuration tool
- Library of pre-defined standard configurations
- Support of user defined SPA messages in acyclic Profibus messages
- Support of RS-485 Profibus interface
- Support of circuit breaker control operations in selected configurations
- Support for up to 16 SPA slaves
- Reading multiple binary data by using SPA (packed data read features in templates)

All relay data can be accessed through the SPA-ZC 302 gateway. If the standard configuration templates do not include needed data, contact your ABB representative.

2.2. Module parts

- 1 Profibus D-connector
- 2 SPA bus D-connector
- 3 Profibus communication LEDs
For details, see Section 8.3.1.
- 4 SPA communication LEDs
For details, see Section 8.3.1.
- 5 DIP switches
- 6 Auxiliary power connector

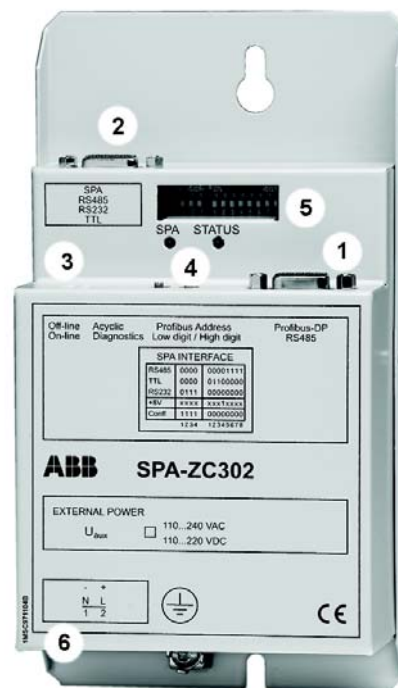

A050293

Fig. 2.2.-1 Parts of SPA-ZC 302

2.3. Ordering information

SPA-ZC 302-BA

- SPA-ZC 302 module
- Connection cable for configuring SPA-ZC 302 module and connecting SPA bus relays, for example REF 541/3/5, RET 541/3/5, REM 543/5 and SPACOM (Order number: 1MRS120541)
- Connection cable for SPA bus relays, for example REX 521, RE_610 relays and SACO annunciator units (Order number: 1MRS120539)
- Gender changer
- This manual
- SPA-ZC 302 configuration CD



With REF 541/3/5, RET 541/3/5 and REM 543/5, the following cable information must be noticed:

- SPA-ZC 302 to port X3.2 (RS-232, protocol 2). Use cable 1MRS120513-003. This has to be ordered separately.
- SPA-ZC 302 to port X3.3 (RS-485, protocol 3). Use cable 1MRS120541 included in the delivery of SPA-ZC 302.

2.4. Additional support products

In cases where the only physical connection to the SPA bus of the protection relay is an optical interface, a SPA-ZC 21 can be used to provide the necessary optical interface from the SPA-ZC 302 gateway. Which variant of SPA-ZC 21 should be used, depends on if glass or/and plastic fibers are available in the SPA bus. In addition, it is recommended to use SPA-ZC 21 and an optical loop to the relays when connecting several relays to SPA-ZC 302. For more information, contact your ABB representative.

2.5. Backwards compatibility

The new gateway contains features, such as the event channel and reading multiple binary data, affecting the configuration template format.

The gateway software version 2.0 is compatible with the old configuration template format. In this compatibility mode, it works as an older 1.03.03 device. There are two ways to activate the compatibility mode:

- You can download the old configuration template with the old PCT tool (Profibus DP/SPA Gateway Configuration Tool).
- Or you can select **Download as > v1.02** in the new PCT tool version.

The new PCT tool automatically converts and saves the old configuration template to the new format.



The new template file format is not compatible with the old PCT tool.

3. Installation

This chapter describes the mechanical installation of the SPA-ZC 302 module. It also describes the electrical configuration of the gateway for different SPA bus types and supply voltages. For additional information, refer to Chapter 7. Technical data and Chapter 8. Maintenance and service.

3.1. Application

A Profibus-DPV1/SPA gateway is used to connect SPA bus devices to the Profibus DP fieldbus.

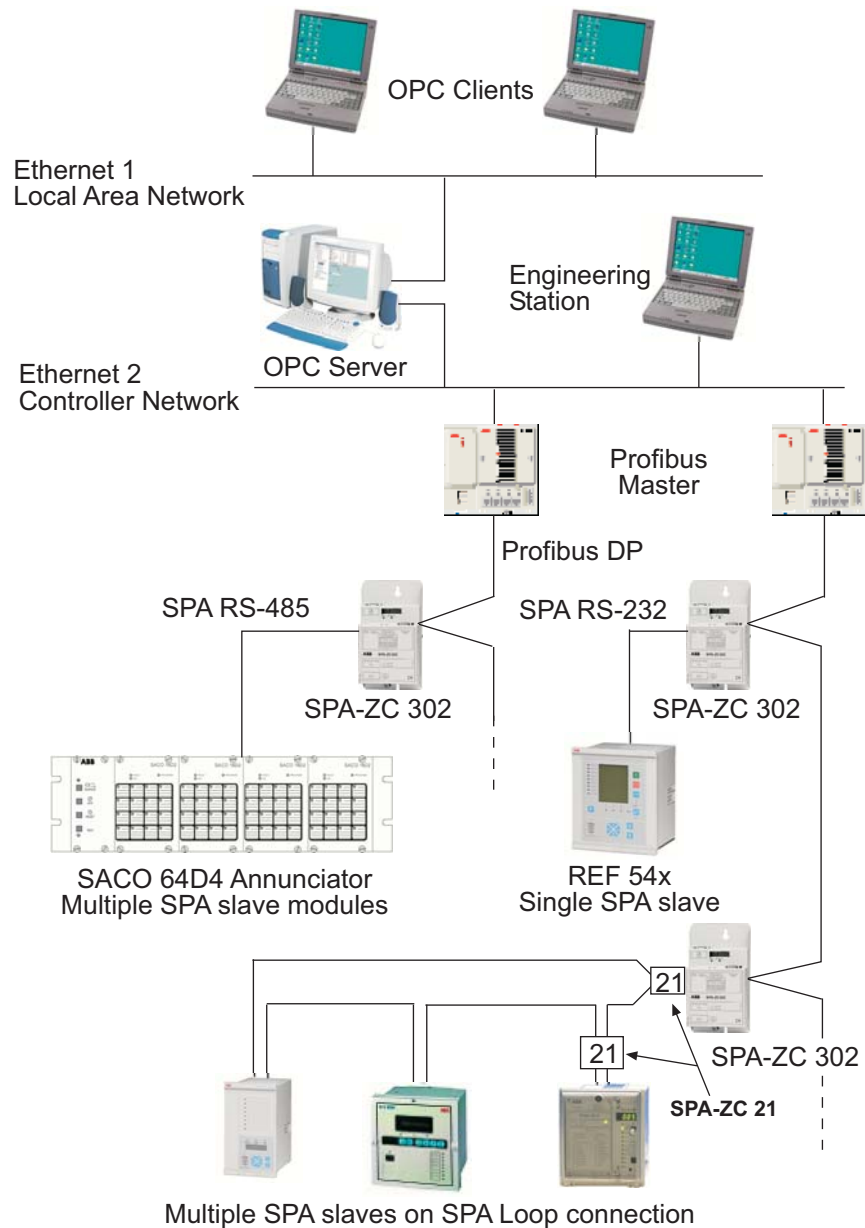

Fig. 3.1.-1 Conceptual picture of a typical system setup

A050290

Installation and Commissioning

3.2. Mechanical installation

1. Fix the module with two screws on the bottom or wall of the cubicle, near the protection relay that the module will be connected to. Notice the length of the SPA connection cable.
2. Ensure that the DIP switch configuration of the module is correct, see Section 3.3.3.3. DIP switch configuration.
3. Connect the SPA communication cable between the SPA relay and D-connector of the SPA-ZC 302, for details, see Fig. 3.1.-1. If you connect several relays, use a SPA-ZC 21 on the SPA-ZC 302's SPA port and build an optical loop connecting all the relays.
4. Connect the twisted pair cable to the Profibus D-connector of the SPA-ZC 302. The other end of the cables is connected to a Profibus DP master.



Profibus requires that the last device in the daisy chain must be terminated.

3.3. Electrical installation**3.3.1. Auxiliary power connection**

Voltage range for the external power connection (U_{aux}) is 110-240 V AC/DC.

Table 3.3.1-1 Screw terminal of U_{aux} connection

Screw terminal	AC	DC
1	N	-
2	L	+

In addition, there is an earthing screw for the protective earth conductor beside the screw terminals in the casing. Refer to Fig. 2.2.-1 for the location of the auxiliary power connectors.

3.3.2. Profibus DP version 1 bus interface

The Profibus DP version 1 bus interface of the gateway consists of the following parts:

- A 9-pin D-type sub miniature connector
- Two rotary switches for address selection
- Four LEDs for status and diagnostic purposes

3.3.2.1. RS-485/Profibus DP version 1

The Profibus DP version 1 interface is able to handle serial communication with RS-485 levels.

It is recommended to use a Profibus connector that does not cover DIP switches or status LEDs. Some of the commonly used connectors can easily be flipped to face right or left.

Installation and Commissioning

The pin numbers of the RS-485/Profibus DP version 1 bus connection are presented in Table 3.3.2.1-1.

Table 3.3.2.1-1 Profibus DP version 1 connector

Pin	Usage
Housing	Shield, connected to Power earth
1	Not connected
2	Not connected
3	B-line, Positive RxD/TxD according to RS-485 specification
4	RTS, Request to send
5	GND BUS, Isolated GND form RS-485 side
6	+5V BUS, Isolated +5V from RS-485 side
7	Not connected
8	A-line, Negative RxD/TxD according to RS-485 specification
9	Not connected

3.3.2.2.

Address selectors

The addressing of the device can be done in two ways:

- The first and easiest way is to select the slave address using the rotary switches that are located in front of the device, see Fig. 3.3.2.2.-1. Using this method, the addresses 0-99 can be selected.
- If the rotary switches are set to address 0 (zero), the slave address can be set by using the Profibus Configuration Tool (PCT), see Section 5.2. Starting PCT.

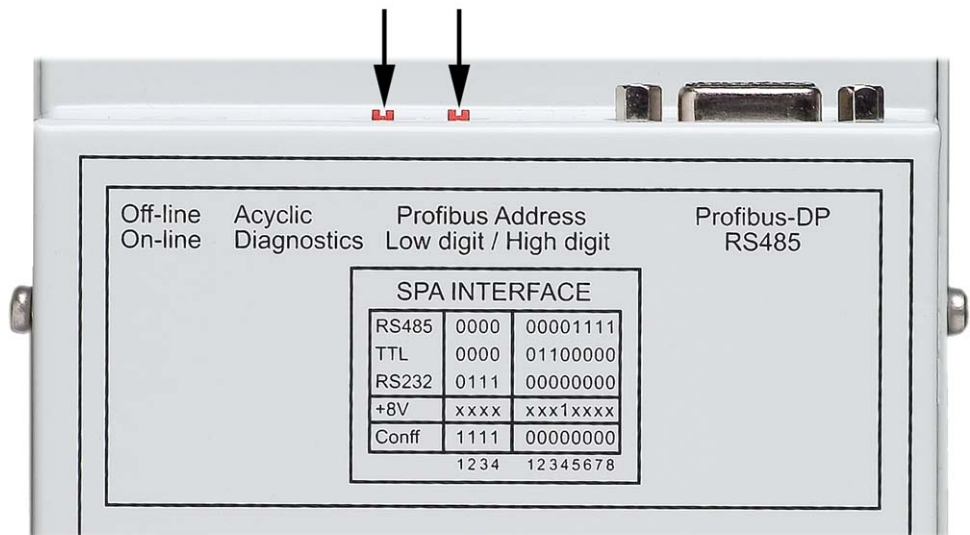

A050339

Fig. 3.3.2.2.-1 Address selectors in SPA-ZC 302

If no address is set, use the default address 125. Changing of the Profibus address requires reboot of the gateway, that is through power off/on, or by changing to application mode from the configuration mode using the A1 DIP switch, see Section 3.3.3.3. DIP switch configuration.

3.3.2.3. Profibus DP communication speeds

Table 3.3.2.3-1 Communication speeds

Baud rates supported
9.6 kbit/s
19.2 kbit/s
45.45 kbit/s
93.75 kbit/s
187.5 kbit/s
500 kbit/s
1.5 Mbit/s
3 Mbit/s
6 Mbit/s
12 Mbit/s

The communication speed is automatically detected by the gateway when it is connected to the Profibus.

3.3.3. SPA bus/configuration interface

The gateway is provided with a 9-pin D-connector. The interface types are RS-232, RS-485 or TTL. The DIP switches located on the connector board beside the D-connector are used to set signal types and supply voltage.

Table 3.3.3-1 SPA bus connector

Pin	Usage
Housing	Shield connected to power earth
1	RS-485 A-line, Negative RxD/TxD
2	RS-485 B-line, Positive RxD/TxD / RS-232C TxD / TTL RxD
3	RS-485 RTS A (-) / RS-232C RxD / TTL TxD
4	RS-485 RTS B (+)
5	Signal ground
6	Not connected
7	Signal ground
8	+5 V supply voltage source
9	+8 V supply voltage source

3.3.3.1. Communication settings

The SPA settings are 7 data bits, 1 stop bit and even parity. The SPA interface settings shall be the same regardless if RS-485, RS-232 or TTL level is used.

3.3.3.2. SPA bus communication speeds

Table 3.3.3.2-1 Communication speeds

Baud rates supported
1.2 kbit/s
2.4 kbits/
4.8 kbit/s
9.6 kbit/s
19.2 kbit/s
38.4 kbit/s

The SPA baud rates can be set through the Profibus-DPV1/SPA Configuration Tool (PCT), to match the connected relay. If several relays are connected, they all use one common baudrate.

3.3.3.3. DIP switch configuration

The SPA interface is configured by using DIP switches located beside the DSUB9 connectors. To select the correct DIP switch number, follow the instructions in Table 3.3.3.3-1 and see Fig. 3.3.3.3.-2:



For the safety, set the active DIP switches to OFF position before switching on the new settings when changing the interface type. Only one interface type must be active at a time. The state of the DIP switches can be changed without turning the power off.



The smaller group of DIP switches is referred to as group A, and the larger group as group B, see Fig. 3.3.3.3.-2.



A050336

Fig. 3.3.3.3.-1 DIP switch configurations A1-4 and B1-8

The DIP switches A1-4 and B1-8, see Fig. 3.3.3.3.-1, are described in Table 3.3.3.3-1

Installation and Commissioning

Table 3.3.3.3-1 DIP switch configurations A1-4 and B1-8

DIP switch no	Interface type	Description
B5-8	RS-485	This interface type is supported by most protection relays
B4	RS-485/ TTL/ + 8 Volt supply voltage	This interface type is used for powering additional adapters, such as SPA-ZC 21(RS-485/TTL to optical converter for the SPA bus)
B2-3	TTL level	This interface type is supported for example by the SPAJ 140 C protection relay
B1	-	DIP switch B1 is not connected
A2-4	RS-232	This interface type is necessary when configuring the gateway and is also supported by some protection relays.
A1	Configuration mode	DIP switch A1 puts the gateway into configuration mode. This switch must be ON whenever communication is required between PCT and the gateway. When this switch is ON, the RS-232 interface type shall also be selected

In the gateway version 2.0, the DIP switch configuration has changed from the version 1.03.03, see Fig. 3.3.3.3.-2 for the new ON-OFF direction.

Installation and Commissioning

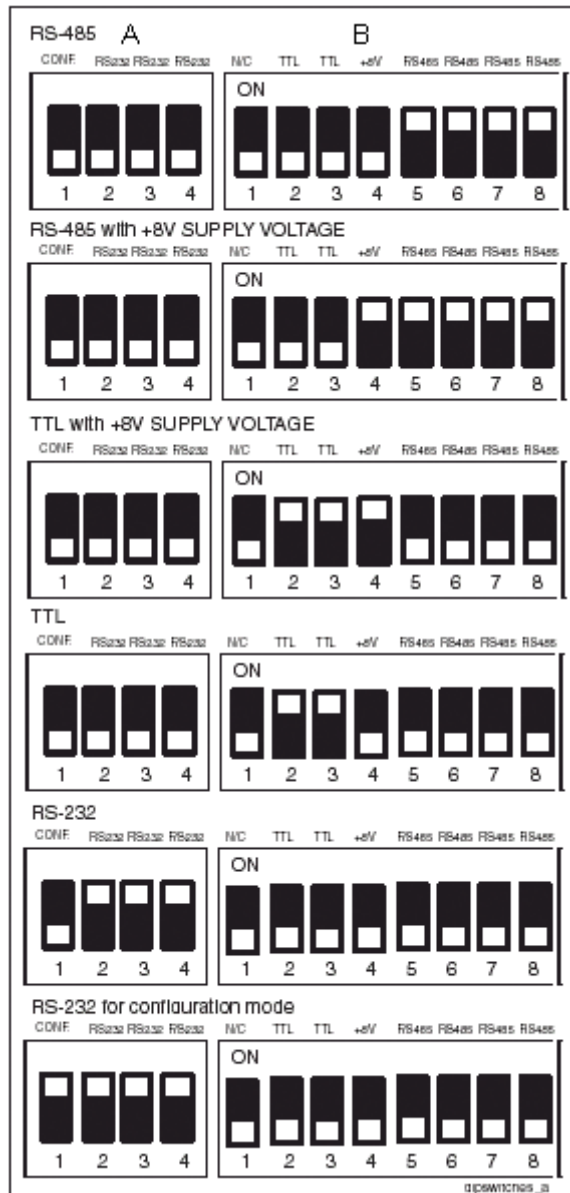

A050292

Fig. 3.3.3.3.-2 DIP switch configurations A1-4 and B1-8



If the new DIP switch configuration requires changing of communication port in the SPA slave, the Module status word indicates SPA off-line status (bit 3=1). Refer to Section 5.1. Program overview for more information about the Module status word.

With several relays in the SPA loop, you actually set the interface between SPA-ZC 21 and SPA-ZC 302, for example RS 485, and activate the +8V supply to SPA-ZC 21.

Installation and Commissioning

3.3.3.4. RS-485/SPA bus cable

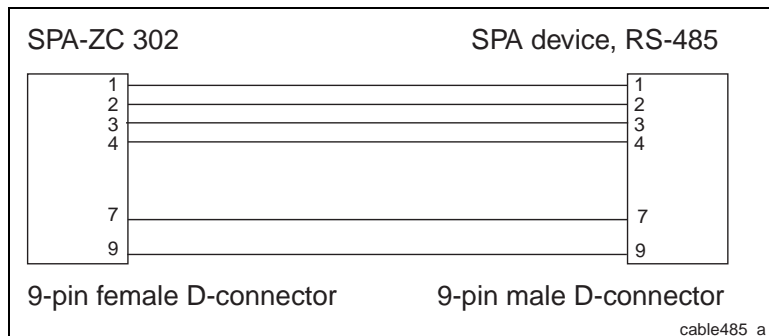
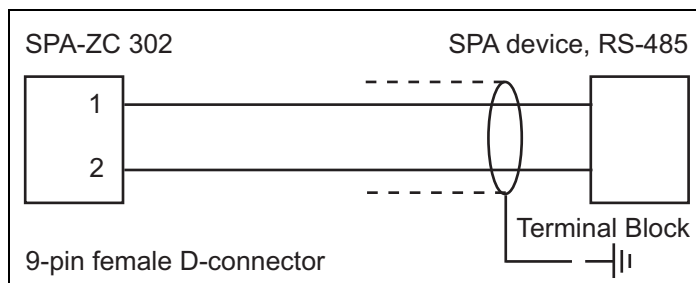

Fig. 3.3.3.4.-1 Interface cable coupling when using RS-485 (Order number:1MRS120541)

Table 3.3.3.4-1 Pin numbers of the SPA bus/RS-485 connection

Pin	Usage
1	DATA A, data signal pair, signal A (+)
2	DATA B, data signal pair, signal B (-)
3	RTS A, request to send signal pair, signal A (+)
4	RTS B, request to send signal pair, signal B (-)
7	GND, signal ground
9	+8V, optional power supply from the SPA-ZC 302

3.3.3.5. RS-485/SPA bus cable



A050352

Fig. 3.3.3.5.-1 Interface cable coupling when using RS-485 with, for example, REX 521, RE_610, SACO annunciator unit

Table 3.3.3.5-1 Pin numbers of the SPA bus/RS-485 connection

Pin	Usage
1	DATA A, data signal pair, signal A (+)
2	DATA B, data signal pair, signal B (-)

Installation and Commissioning

3.3.3.6. TTL/SPA bus cable

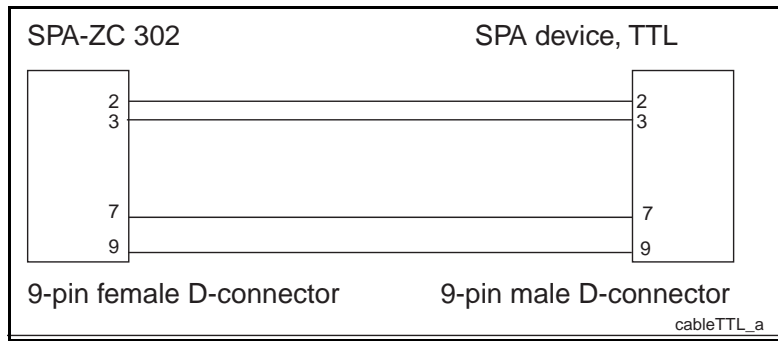

Fig. 3.3.3.6.-1 Interface cable coupling when using TTL (Order number: 1MRS120541)

Table 3.3.3.6-1 Pin numbers of the SPA bus/TTL connection

Pin	Usage
2	RXD, data from SPA bus device
3	TXD, data to SPA bus device
7	GND, signal ground
9	+8V, optional power supply from SPA-ZC 302

3.3.3.7. RS-232/SPA bus cable

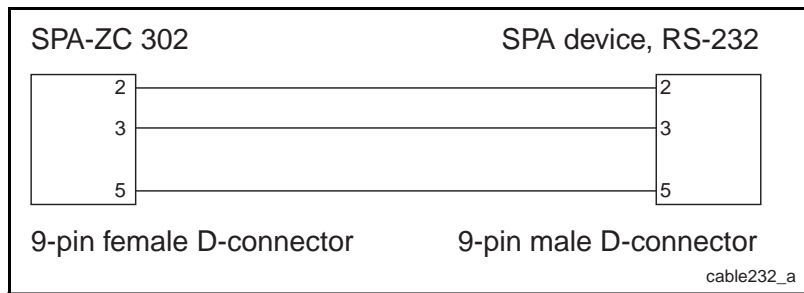

Fig. 3.3.3.7.-1 Interface cable coupling when using RS-232 (Order number: 1MRS120541)

Table 3.3.3.7-1 Pin numbers of the SPA bus/RS-232 connection

Pin	Usage
2	TXD, data to SPA bus device
3	RXD, data from SPA bus device
5	GND, signal ground

3.3.3.8. SPA loop

When you connect more than one SPA relay to the same gateway, the relays should be connected by means of an optical SPA loop, see Fig. 3.3.3.8.-1.

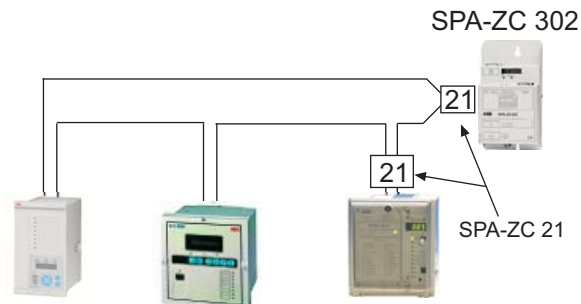

A050338

Fig. 3.3.3.8.-1 Multiple SPA slaves in SPA loop connection

3.3.3.9. Configuration cable

You can connect the gateway and the PC by using a standard straight serial cable or the SPA cable that comes with SPA-ZC 302 as a configuration cable.

3.4. Installing Profibus-DPV1/SPA Configuration Tool

3.4.1. System requirements

The Profibus-DPV1/SPA Configuration Tool (PCT) user interface requires a 32-bit version of Microsoft Windows® (Windows NT/2000/XP/98). A serial port must also be available on the PC.

Necessary proprietary cables are included in the SPA-ZC 302 configuration package, see ordering information in Section 2.3.

3.4.2. Installing the software

To install the PCT software, you need a working directory on a hard drive with full read/write access. The software can also be run directly from the CD.

The installation program will install the required files on the hard drive while giving you information about the progress. It also performs the required changes to the Windows registration for the installed files.

Insert the CD-ROM into the CD-ROM drive (for example drive D:). The installation will start automatically if the Autorun option is active on your PC. If it is not active, start the installation by selecting Run from the Start menu, and defining the command line in the Run dialog, as shown in Fig. 3.4.2.-1 below, or by double-clicking the PCT.EXE file in Windows Explorer.

Installation and Commissioning

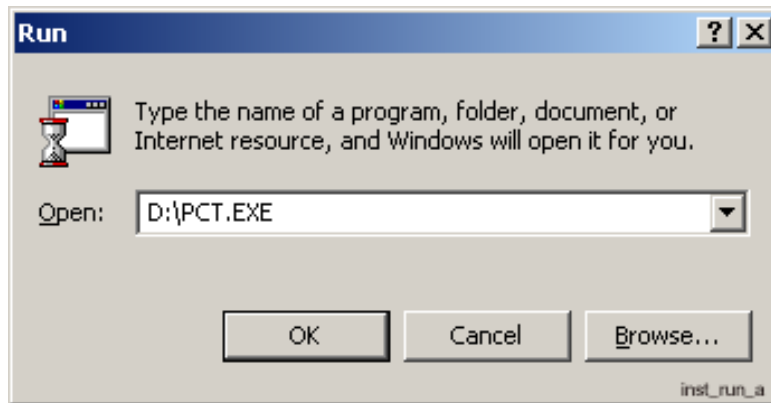

Fig. 3.4.2.-1 PCT installation

When the installation program has started, follow the step-by-step instructions given on the monitor.



To view the manuals, you can use the free Adobe Reader software. Adobe Reader 7.0 for Windows XP and Windows 2000 SP2 are included in the installation CD. To install the Reader, start the Adobe Reader installation file located in the ADOBE READER 7.0 folder on the CD. If your operating system is older than Windows XP or Windows 2000 SP2, you have to install the Reader by downloading the appropriate version for the operating system from <http://www.adobe.com>.

3.4.3.

Uninstalling the software

By using the **Add > Remove Programs** command in the Control Panel, it is possible to uninstall the software from the PC. The Control Panel is opened by selecting **Settings > Control Panel** from the Start menu.



If you uninstall the software, the gateway configuration data is removed from the computer. If you want to save the configuration data, you need to make copies before uninstalling.

4. Commissioning

This chapter describes the commissioning of the gateway by using Profibus-DPV1/SPA Configuration Tool (PCT).

The commissioning phase includes following actions in short:

1. Set the gateway to configuration mode.
2. Connect the PC containing the Profibus-DPV1/SPA Configuration Tool to the gateway.
3. Open a standard configuration and define the SPA addresses and scaling. In a multislave project, you can import several standard configurations to the different slave sections in PCT. For more information, refer to Section 4.3. Multislave configuration.
4. Save the configuration with a new name.
5. Download the configuration and, optionally, the source to the archive.
6. Connect the gateway to the protection relays and start it up.
7. Connect the gateway to the PC again and upload the configuration.
8. Verify that the appropriate In Use flags are checked.

See the following sections for details about the actions.

4.1. Hardware set-up

The gateway and the PC hardware must be connected and set up properly in order to perform a successful configuration of the gateway.

If the ordered product package is a SPA-ZC 302-AA or BA, the provided connection cable (1MRS120541) can be used for configuration purposes if a gender change adapter (female-female) is used for the PC connection.

Connect the cable between the COM port on the PC and the SPA protocol port on the gateway device. If your PC contains only USB ports, you need an USB to COM port adapter, which can be purchased from any well-equipped computer store.

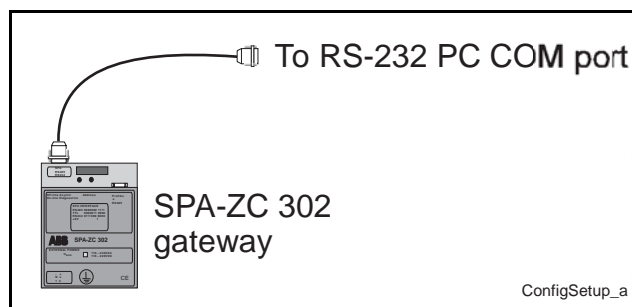

Fig. 4.1.-1 Configuration arrangement principle

The SPA protocol port setting must be set to RS-232 using the DIP switches as described in Section 3.3.3.3. DIP switch configuration.

Ensure that PCT is set to use the serial port that the cable is connected to. Check this by selecting **Settings > COM** in the main menu in PCT. For details about PCT, see Section 5.2. Starting PCT. PCT adjusts the COM port settings of the PC automatically.

4.2. New configuration

Before a new configuration is started, you have to select a standard configuration template from the configurations described in Chapter 6. Standard configuration templates. Which one you should select, depends on the requirements of the system in which the protection relay and the gateway device are installed.

When you have selected the standard configuration template, you have to define the protection relay dependent data and commission the gateway by following the instructions below:

1. Start the PCT and open the selected standard configuration template by selecting **File > Open** in the main menu. Select the wanted standard configuration template and click **Open**, or just double-click on the template you want.

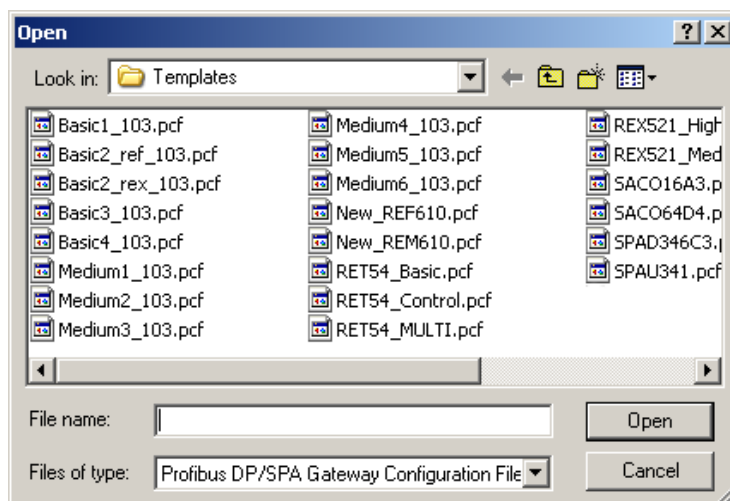

A050341

Fig. 4.2.-1 Opening the configuration template

Define the address of the SPA slave connected to the gateway by selecting **Slave > Set Address** and type in the address in the SPA Slave Address dialog, see Fig. 4.2.-2.

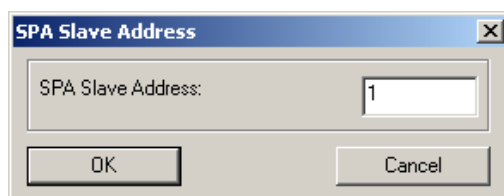

A050295

Fig. 4.2.-2 Setting the SPA Slave Address

Installation and Commissioning Manual

If the connected SPA slave is a SPACOM relay with several modules and addresses, such as SPAD 346 C or SACO 64D4, the standard configuration can have several addresses defined in it already. In this case, PCT automatically creates a tabbed page for each address or slave module.

If you do not have a suitable standard configuration or you have a standard configuration made for one of the modules, you can do as follows:

1. Open the configuration.
2. Add the slaves for each module.
3. Import the configuration again for each slave as if there were several relays connected.

Select a signal in the Template info field in the PCT and click the **Edit** button, or double-click on the signal. A dialog is opened where you can set the SPA slave address for that signal, see Fig. 4.2.-3 number 1.

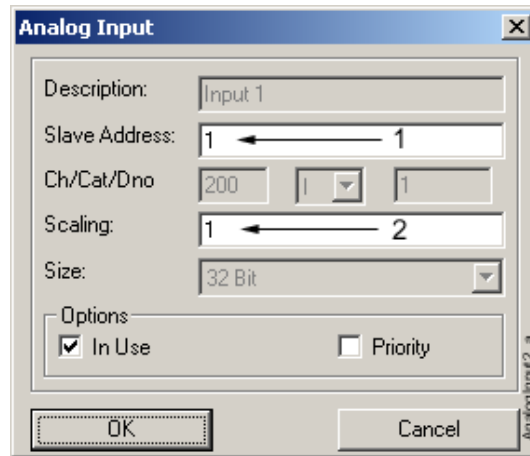

Fig. 4.2.-3 Analog Input settings

4. When you have defined the SPA slave address or several addresses, the scaling factors should be defined for necessary signals. The signals that need to be defined are pre-dominantly measurement signals that get their input from measurement transformers and sensors. Scale the necessary signals by selecting a signal in the template info section of the PCT and click the **Edit** button, or by simply double-clicking on the signal. A dialog is opened where you can define the scaling factor for that signal, see Fig. 4.2.-3 number 2. To calculate the value on the SPA bus, use the following formula:

$$\text{SPA_Value} = \frac{\text{Profibus_Value}}{(\text{parameter scaling} \times 10^{\text{Decimal_place}})}$$

To calculate the value on Profibus, use the following formula:

$$\text{Profibus_Value} = \text{SPA_Value} \times (\text{parameter scaling} \times 10^{\text{Decimal_place}})$$

The default value is 1.

5. Once you have defined a configuration, you can save, use, and re-use it to connect the same type of protection relay or a system of multiple relays to a gateway. The configuration is preferably saved on a different location on the disk, and with a different name than that of the standard configuration template.
6. Define the Profibus address by either setting the address selectors on the front of the gateway to the selected address, or by setting the selectors to zero and defining the selected Profibus address in PCT. For details, see Section 5.2. Starting PCT. To read the address selectors correctly, the gateway should be held so that the Profibus DP connector is situated on the left side of the address selectors. If the address is set by using the address selectors, the gateway must be restarted before the address takes the effect. The address selectors are marked as High Digit or Low Digit in the gateway.

4.3. Multislave configuration

If several relays are connected, you may have a ready made configuration template for the multislave system that consist of several slaves. Otherwise, you should start from the configuration template matching the first relay. Then you can add the other slaves and import the configurations to each slave.

If you open the configuration template matching the whole system, you just have to set the automatically created addresses of each slave.

If you do not have a ready made multislave configuration, do as follows:

1. Open the single slave configuration template and set the address of the first relay by selecting **Slave > Set address**, see Fig. 4.3.-1.

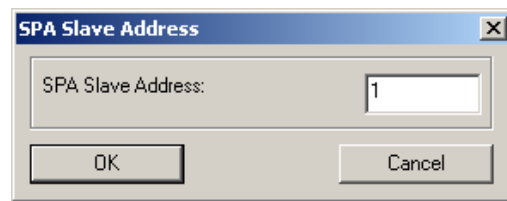

A050295

Fig. 4.3.-1 Setting SPA Slave Address

2. Select **Slave > Add** to add all the slaves in your multislave system.

When all the slaves are added, you have one tabbed page for each slave, see Fig. 4.3.-2. The first page already includes the opened configuration template and has the address that was just set.

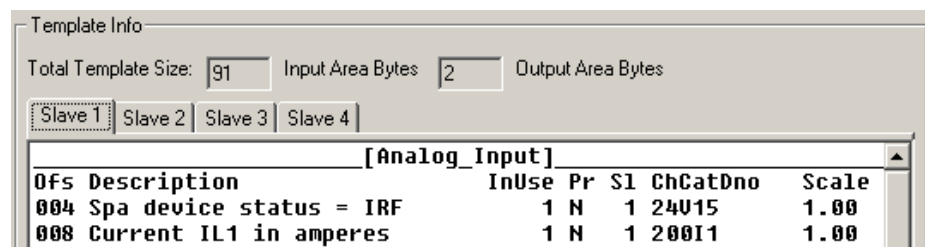

A050340

Fig. 4.3.-2 Template info field with tabbed pages for the different slaves

3. Select the next tabbed page representing the second slave.
4. Select **Slave > Import** to open a dialog for importing the configuration template, see Fig. 4.3.-3.

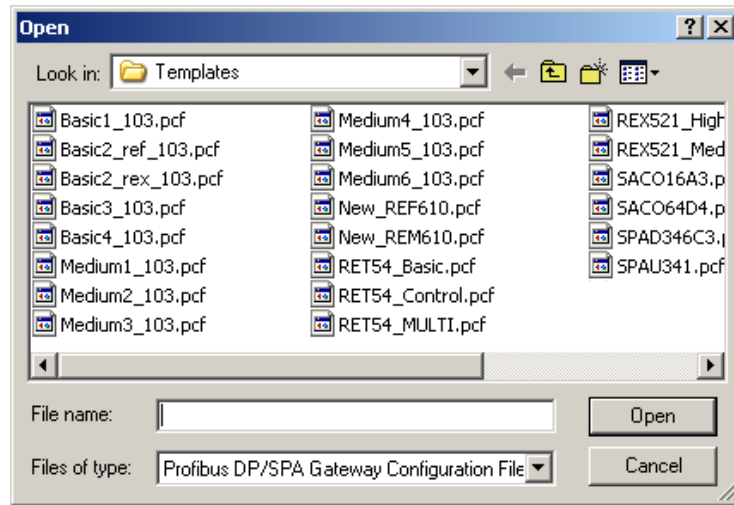

A050341

Fig. 4.3.-3 Importing the configuration template

5. In the Import dialog, select the configuration matching the second relay.
6. Select **Slave > Set address** to set the address of the second relay, see Fig. 4.3.-1.
7. Repeat these steps for all the slaves and always check the total template size while adding slaves and importing their configurations.

After each import, remove the unnecessary data items. It helps you to keep total template size under 240 bytes and removes unnecessary profibus traffic.



All the data included in the template is transferred in the profibus side, even in case the slave does not contain these specific data items.

The response time is highly dependent on the number of the connected SPA slaves and the size of the configuration. For more information, refer to Section 8.4.1. Gateway diagnostics.

When verifying signals in a multislave system, all the relays must be connected. Otherwise the In Use flags of an entire slave might be deactivated.

4.4.

Downloading configurations

When a configuration is defined, it is time to download it to the gateway by following the instructions below:

1. If you have downloaded the configuration file directly after the configuration definition described in the preceding Section 4.2. New configuration, jump to step 2. In other cases, start the PCT and open the selected standard configuration template by selecting **File > Open** in the main menu, and by double-clicking on the wanted standard configuration template name.

2. Ensure that the correct COM port is selected from the **Settings > COM** menu in PCT.
3. Also ensure that the gateway is in configuration mode. Configuration mode is enabled by using the DIP switches on the front of the gateway, see Section 3.3.3.3. DIP switch configuration.
4. Select **Device > Download** configuration in the main menu. The configuration is now downloaded and a confirmation dialog is displayed. Click **OK** to confirm the download, see Fig. 4.4.-1.

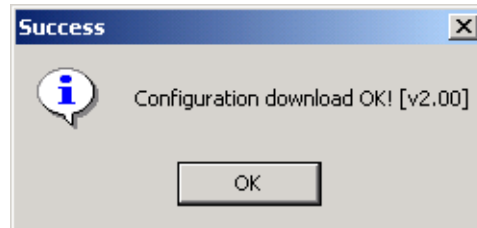

A050353

Fig. 4.4.-1 Configuration download succeeded

This step is optional but it is a good practice to also download the configuration source to the gateway. In this way the gateway always contains all the necessary data that can be used in the future. The configuration archive can be downloaded as such or compressed to a zip file. After that, select **Device > Download Archive** in the main menu and a file selection dialog is opened. Select the saved configuration that has been made for the gateway "<filename>.pcf" and click **Open**. When this is done, the archive will be downloaded to the device and the a confirmation dialog is shown, see Fig. 4.4.-2. Click **OK** to confirm the archive download. For more information on LEDs, see Section 8.4. Troubleshooting.



Fig. 4.4.-2 Archive download succeeded

The archive is stored in the device until another archive is downloaded and the new archive overwrites it.

5. In order to verify the signals that are actually read from the protection relay:
 - The configuration is uploaded after the first start-up with the protection relay connected.
 - The state of the In Use flag is checked.

For details on how to do this, see Sections Section 4.7. In Use flags.

4.5. Gateway initialization

When the gateway is set into application mode from the configuration mode by using the DIP switch, see Section 3.3.3.3. DIP switch configuration, the gateway starts to go through the configuration one parameter at a time to verify that the source parameter is available in the protection relay. If a parameter does not answer on the data request from the gateway, the In Use flag will be reset, see Section 4.6. Time synchronization.

The gateway polls only the parameters that have the In Use flag set. In the profibus side, parameters which cannot be read from the SPA device report the value 0xFF, 0xFFFF or 0xFFFFFFFF according to the size of the data, except for the values that are updated by events that have the value 0x0F.

The state of the In Use flags is stored into the non-volatile memory. This means that supply power interruption will not affect the configuration and the gateway will start up normally.

The process data is valid when the gateway mode bit indicates application mode and SPA initializing is zero. There is a separate data-valid bit for each slave. Bit 3 must be zero (SPA On-line). If bit 5 indicates a configuration warning, some of the data is invalid (unavailable). The unavailable items are reported with 0xF in the Profibus message. For the valid process data, the SPA device status (IRF) information should indicate no errors. The initial states of the digital inputs are polled from the SPA slave. After this, if declared, events are used to update the inputs.



The SPA event mask has to be open for these signals. Only one SPA master can read events from the SPA slave at a time.

4.6. Time synchronization



To enable the Time synchronization feature of the gateway, a Profibus-DPV1 master that is capable of writing acyclic messages to specific slots must be used. It is important that the protection relay does not receive time synchronization signals from more than one source.

The time synchronization feature of the gateway requires that the internal clock of the gateway is set. The gateway time is then used to synchronize the protection relay. Set the gateway clock by writing the date to slot 0 of the acyclic output and the time to slot 1 according to Table 4.6.-1.

Table 4.6.-1 Time synchronization formats

Slot	Index	Name	Size	Description	Range
0	0	Year	WORD	Year in format-yyyy-	0-9999
	4	Month	BYTE	Month in format -mm-	1-12
	5	Day	BYTE	Day in format -dd-	1-31
1	0	Milliseconds	WORD	Milliseconds in format -sss-	0-999 ¹⁾
	1	Seconds	BYTE	Seconds in format -mm-	0-59
	4	Minutes	BYTE	Minutes in format -mm-	0-59
	5	Hours	BYTE	Hours in format -hh-	0-23

1)When the gateway detects a change in this field, it will update the internal date and time counter to be used when synchronizing the SPA slave device. The time synchronization is enabled by selecting the option in PCT, for details see Section 5.4.7.1.

4.7.

In Use flags

The In Use flags, that are present on all signals, indicate if the signal is available in the protection relay.

The In Use flag can be handled in two ways:

- The gateway automatically detects what signals are present in the protection relay and sets or resets the flag accordingly.
- The flag can be set manually by setting, or resetting, the check box in the signal dialogs.

It is recommended to let the gateway determine the signals that are available in the protection relay.

If a signal is read from the protection relay, the gateway will report the actual value of the signal on Profibus. If a signal is not read from the protection relay, the gateway will report a value of 0xFF (255), 0xFFFF (65 535), or 0xFFFFFFFF (4 294 967 295) depending on the data type of the signal on Profibus.

This mechanism makes it possible to use the available standard configuration templates in a flexible way, by selecting a template that contains the necessary signals. If there are signals defined in the template that are not present in the protection relay, the maximum value for the data type of the signal is reported by default. In other cases the signal's actual value is reported.



If you do not want the 0xFFFF values to cause unnecessary traffic on the profibus side, you should remove all the parameters that could not be found in the relay from the configuration and download it again. This changes the data size on the profibus side. The master application must be updated accordingly.

5. Profibus-DPV1/SPA Gateway Configuration Tool

5.1. Program overview

With the Profibus-DPV1/SPA Gateway Configuration Tool (PCT) you can perform the following tasks:

- Download and upload the configuration file from the gateway
- Load stored configurations for the gateway
- Save configurations for the gateway
- Upload and reset SPA diagnostics
- Configure SPA protocol parameters
- Set default Profibus node address
- Set priority of SPA messages, decimal place for analog values and scaling for analog values
- Create Indirect SPA messages
- Global disabling/enabling of event polling
- Create multislave configurations by using several singleslave templates
- Remove slaves or parameters to keep the total configuration template size smaller than 240 bytes

5.2. Starting PCT

The PCT is started by clicking Start and selecting **Programs > ABB > Profibus DPV1 SPA Gateway SPA-ZC 302 > Profibus DPV1 SPA Gateway SPA-ZC 302 Configuration Tool**.

5.3. Main view

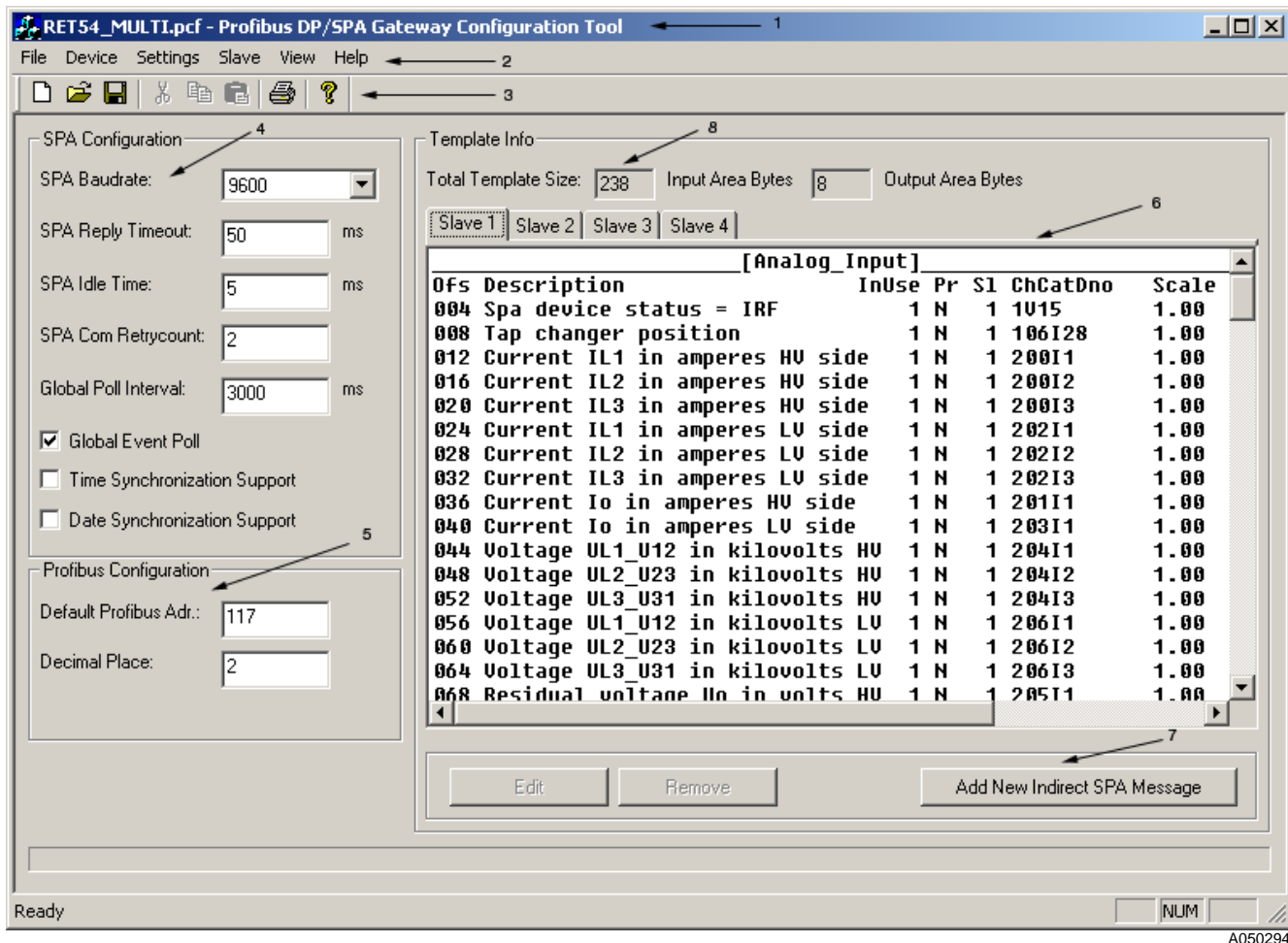

Fig. 5.3.-1 Main view of the Profibus DP/SPA Gateway Configuration Tool

The PCT main view consists of the following fields, see Fig. 5.3.-1:

1. Title Bar
2. Main Menu
3. Toolbar
4. SPA Configuration field
5. Profibus Configuration field
6. Template info field with one tabbed page for each slave
7. Indirect SPA Messages
8. Total template size field

5.4. PCT menus

This section describes the main menu, the submenus and commands that are available in PCT.

5.4.1. File menu

The File menu contains the following functions:

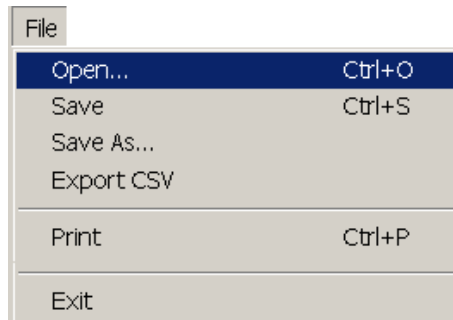

A050342

Fig. 5.4.1.-1 File menu

5.4.1.1. Open

To open a ready-made configuration file in the PCT, select **File > Open** in the main menu, or click on the corresponding icon in the toolbar. Select the wanted configuration in the dialog, and click **Open**. The selected configuration will be shown in the Template info field on the right. You can modify the configuration by selecting the signal that you want, and clicking **Edit**, or by double-clicking on the signal. For details see Section 5.4.8. Template info.

5.4.1.2. Print

To print, select **File > Print** in the file menu, or click on the print icon in the toolbar. A print dialog is opened in which you can select printing options. Confirm the dialog by clicking **OK**. To cancel, click **Cancel** to close the dialog.

5.4.1.3. Save / Save As

To save the configuration made in the PCT, select **File > Save** in the main menu or click the corresponding icon in the toolbar. If you want to give the configuration a new file name, select **File > Save as** in the main menu. Type the new name of the configuration in the field and click **Save**.

5.4.1.4. Exit

Select **File > Exit** in the main menu to exit the program. If a document with unsaved changes is open, a dialog will prompt you to save the changes first.

5.4.1.5. Export csv

To export the template file to Excel, select **File > Export csv**. The .csv format contains all the necessary information for documenting your project and can also be useful when engineering the master application.

5.4.2. Device menu

In the Device menu you can select between different download and upload alternatives or check the firmware version of the device, see Fig. 5.4.2.-1.

All operations in this menu are possible to perform only when the gateway is in configuration mode. For details, see Section 8.4. Troubleshooting.

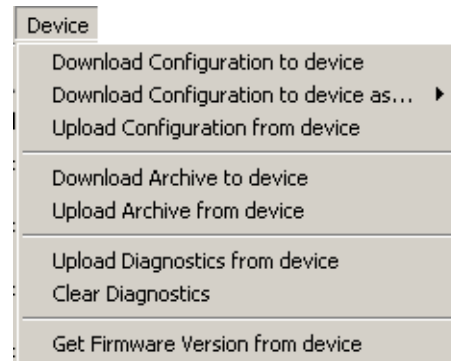

A050337

Fig. 5.4.2.-1 Device menu

5.4.2.1. Download/upload configuration (as)

To download or upload the configuration file of the gateway, select **Device > Download Configuration (as)** or **Upload Configuration** in the main menu. By selecting **Download Configuration to device as v.1.02 or 2.0**, you can download the configuration template to the old gateway version by using the new tool. For details see Section 4.4. Downloading configurations.



The old gateway does not support event channel or packed data types.

5.4.2.2. Download/upload archive

The archive is intended for storing the configuration source file of the gateway for future use. It is however recommended that the configuration is also stored in some other file for safety.

To download or upload the archive of the gateway, select **Device > Download Configuration or Upload Configuration** in the main menu. For details see Section 4.4. Downloading configurations.

5.4.2.3. Upload diagnostics

The gateway contains a supervision functionality that can be uploaded when it is necessary to verify or check the condition of the gateway. To upload, Select **Device > Upload Diagnostics** in the main menu.

5.4.2.4. Clear diagnostics

To clear and reset the diagnostics described in Section 5.4.2.3, select **Device > Clear diagnostics** in the main menu.

5.4.2.5. Get firmware version

To check the firmware version of the connected gateway, see Fig. 5.4.2.5.-1, select **Device > Get Firmware**.

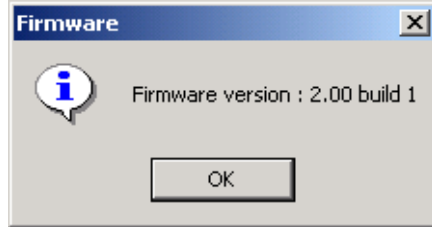

A050355

Fig. 5.4.2.5.-1 Checking the firmware version

The gateway must be in configuration mode when you get the firmware version.

5.4.3. Settings

In the Settings drop-down menu, you can select serial port COM1, COM2, COM3 or COM4.

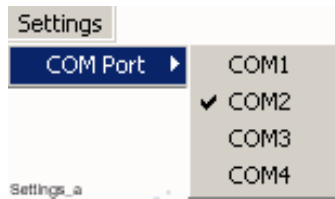
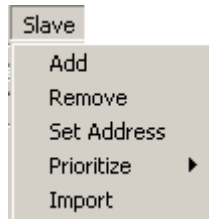

Fig. 5.4.3.-1 Settings menu

5.4.4. Slave menu

In the Slave menu, you can change the slave address for all the signals simultaneously. If you want to change the slave address for all the signals, select **Slave > Set Address** from the Slave menu, see Fig. 5.4.4.-1. For more information, see Section 4.2. New configuration and Section 4.3. Multislave configuration.



A050297

Fig. 5.4.4.-1 Slave menu

Slave Menu includes the following commands:

Add	Add a slave
Remove	Remove a slave
Set address	Set address to the added slave
Prioritize	Prioritize a certain slave, can be either on or off
Import	Import the configuration to a certain slave

5.4.5.

View

In the View drop-down menu, you can select whether to show or hide the toolbar and the status bar in the window.

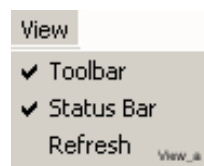

Fig. 5.4.5.-1 View menu

5.4.5.1.

Refresh

To refresh the information in the Template info field, select **View\Refresh** in the file menu, see Fig. 5.4.5.-1. The configuration file that is currently open in the Template info window is reloaded from the disk.

5.4.6.

Help

In the Help menu you will find the About function that shows general information about the PCT.

5.4.7.

Configuration options

5.4.7.1.

SPA configuration

The SPA Configuration field is found on the left hand in the main window, see Fig. 5.3.-1, number 4. Here you can select and define several options when you load an already saved configuration file, see the definitions below:

SPA Baudrate	In this drop-down box, you can select the baudrate to be used by the gateway when communicating with the protection relay. The default value is 9600 bauds.
SPA Reply Timeout	In this text field, you can define the value that will be used by the SPA gateway as a timeout value. Valid timeout values are 10 ms to 500 ms. Default value is 50 ms.
SPA Idle Time	In this text field, you can define the Idle time. Idle time is the time that the gateway will wait before sending the next SPA message when receiving the response of the previous sent SPA message. Valid Idle time values are 5 -10 ms. The default value is 5 ms.

Installation and Commissioning Manual

SPA Com Retry Count	In this text field, you can define how many times the gateway will retry sending a message when failing to get a valid response before continuing with the next message. Valid values are 1-32 times. The default value is 2.
Global Poll Interval	In this field, you can define the idle time of event based updating of digital inputs. If the SPA events are present in the SPA slave, then they are automatically polled with 100 ms interval until the SPA slave has not got anymore events. After this, the gateway checks the SPA slave event buffer with the time interval specified in this parameter. Default value is 3000 ms.
Global Event Poll	By selecting the check box, you can enable polling of SPA Events. The events will be stored into the Event buffer. When disabled, the polling of events will not be performed at all. Event functionality is used by some standard configurations for updating the state values. For details, see Section 6.3. Usage and purpose of SPA protocol events.
Time Synchronization Support	By selecting the check box, you can enable the synchronization of the SPA slave device. If it is enabled, it will be necessary to provide the gateway with the correct time. If the time synchronization is disabled, the gateway will not synchronize the SPA slave devices attached to the gateway. This function requires a Profibus DP version 1 master which is capable of index/slot addressing of acyclic messages.
Date Synchronization support	By selecting the check box, you can enable the synchronization of the SPA slave device. If it is enabled, it will be necessary to provide the gateway with the correct date. If the Date synchronization is disabled the gateway will not synchronize the SPA slave device attached to the gateway. This function requires a Profibus DP version 1 master which is capable of index/slot addressing of acyclic messages.

5.4.7.2.**Profibus configuration**

In the Profibus Configuration field in the main window, see Fig. 5.3.-1 number 5, you can modify the following options:

Default Profibus Adr.	In this text field, you can configure the default Profibus Node Address of the gateway. Valid node addresses are 1-126 for the Profibus DP Version 1 module. A value between 100-126 is recommended. Default address is 125.
Decimal Place	In this text field, you can set how many decimals shall be used when the value is passed to Profibus DP. Valid values are 0-6. Default value is 2. (Since the SPA slave devices can use 10 integer digits and 10 decimal digits, there will be a loss of precision when using too many decimals digits together with integer digits.) For details, see Section Section 5.4.8.7. Scaling of messages.

5.4.8. Template info

The Template info is shown on the right column of the main window. To open a template into the Template info field, select **File > Open** in the main menu, or click the corresponding icon in the toolbar. The template signal list shows all the signals that exist in the current configuration, see Fig. 5.3.-1, number 6. Use the scroll bar on the right to navigate downwards in the signal list.

The signal types of the SPA slave devices that will be used by the gateway are presented in square brackets in the Template info field. The signal types are the following:

- Analog Input
- Digital Input
- Analog Output
- Digital Output
- Indirect SPA Messages

The description of the signals and their settings are presented in columns in the Template info field.

Each SPA slaves' data is shown on their own tabbed pages. The total template size is shown above the tabbed pages. The maximum size is 240 input bytes or output bytes.

To configure the settings, select a signal and click **Edit**, or double-click on the signal. A dialog with configuration options will pop up. For details, see the sections below. The templates and configuration of the signals will also be described in the following sections.

5.4.8.1. Analog input

When you have opened a template with an analog input into the main window, you can configure the settings that are shown in the Template info field as follows:

1. Select the signal you want to configure and click **Edit**, or double-click on the signal.
2. A dialog is opened where you can modify the settings of that specific signal, see Fig. 5.4.8.1.-1. The fields that you cannot configure are dimmed.
3. To save the new settings, click **OK**. To cancel, click **Cancel** to discard all the changes.

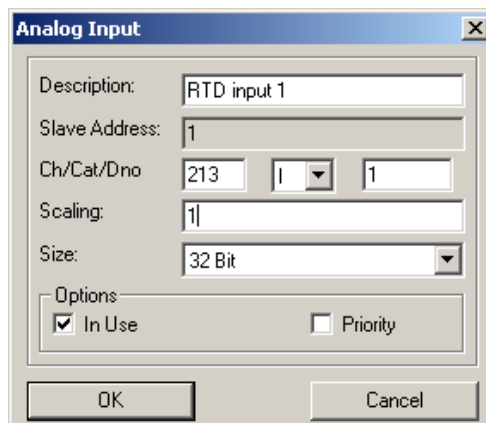

A050343

Fig. 5.4.8.1.-1 Analog Input configuration dialog

The definitions of the analog input signal settings are the following:

Signal name	Description
Slave Address	The slave address of the protection relay or unit
Ch/Cat/Dno	The Channel (Ch), Category (Cat), and the Data number (Dno) where the specific Analog values are read from the SPA slave device.
Scaling	Scaling factor, for details see Section 5.4.8.7.
Size	The size of the analog field on Profibus DP. It can be 16 bit or 32 bit, default is 32 bit. This affects the total template size.
In Use	The In Use flag indicates if the parameter was found in the connected SPA slave device during the initialization phase. In the Template info Field the In Use flag is marked with number 1. An unselected check box indicates that the parameter was not found. For details see Section 4.7. In Use flags.
Priority check box	By selecting the Priority check-box, you can define if the message should be polled more frequently than other messages. This is indicated by the letter P (prioritized) after the signal name in the Template info field. If the signal is not prioritized the letter N (normal) can be seen in the Template info field. The default is N. For details, see Section 5.4.8. Template info.

5.4.8.2.

Digital input

When you have opened a template with a digital input into the main window, you can configure its settings that are shown in the Template info field as follows:

1. Select the signal you want to configure and click **Edit**, or double-click on the signal.
2. A dialog is opened in which you can modify the settings of that specific signal, see Fig. 5.4.8.2.-1. The fields that you cannot configure are dimmed.
3. To save the new settings, click **OK**. To cancel, click **Cancel** to close the dialog to discard all changes.

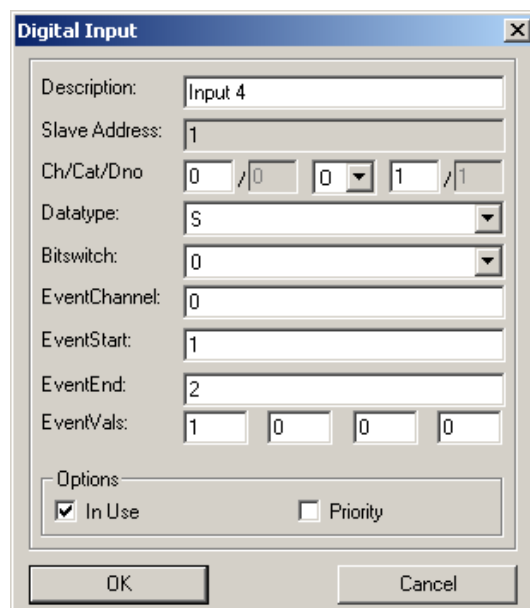

A050296

Fig. 5.4.8.2.-1 Digital Input configuration dialog

The definitions of the digital input signal settings are the following:

Signal name	Description
Slave Address	Slave address of the protection relay or unit.
Ch/Cat/Dno	Channel (Ch), Category (Cat), and the Data number (Dno) where the specific Digital values are read from the SPA slave device.
Datatype	Defines if the SPA data is treated as a single-bit (S), double-bit (D), a hexadecimal value (H) or packed (P).
Bitswitch	Defines if a single-bit is inverted or if a double-bit is swapped. (01->10, 00->00). 0= no swap, 1 =swap.
EventStart	First event to be used when matching an Event for updating the digital input.
EventEnd	Last event to be used when matching an Event for an update of the digital input. Event End cannot exceed EventStart+3, which means that the digital input can only be updated by the four following events.

Installation and Commissioning Manual

EventVals A 2-bit value to be used when updating the digital inputs when matching an Event from the range EventStart to Event End. That is, the event defined in the EventStart field gets the first value and all subsequent events up to EventEnd get the following values.

Example:

In case the settings for a digital input configuration for SPA channel 31 are the following: EventStart = 0, Event End = 1, EventVals = 0,1,0,0, then the events of the SPA slave device will update the value of the digital input to the Profibus as follows:

SPA event code	Profibus value of digital input
E0	0
E1	1

EventChannel Allows gateway to work with a device in which the parameter channel and event channel are different.

In Use The In Use flag indicates if the parameter was found in the connected SPA slavedevice during the initialization phase. In the Template info Field the In Use flag is marked with number 1. A zero indicates that the parameter was not found. For details see Section 4.7. In Use flags.

Priority check box By checking the Priority check box you can define that the message should be polled more frequently than other messages. This is indicated by the letter P (prioritized) after the signal name in the Template info field. If the signal is not prioritized the letter N (normal) can be seen in the Template info field. The default is N. For details, see Section 5.4.8. Template info.

Digital inputs can be updated in two ways:

- By matching an event read by SPA L or B command to the corresponding events defined in the digital input (EventStart to EventEnd).
- Polling values directly from SPA slave devices. These digital inputs should not have any events defined in EventStart or EventEnd. If both of these fields are zero, the digital input should be updated on a regular basis by polling the values from the SPA slave device.

5.4.8.3. Digital input, packed data type

If the datatype is P (= Packed), the SPA message format FirstCh/LastCh and FirstDno/LastDno is used. The datatype numbering of Ch and Dno has to be consecutive when the data type is packed.

The packed data type allows the gateway to read multiple binary data by using one SPA command:

- Enabling faster updating of data, which is always polled and not updated by events.
- Consuming less bytes on the profibus side.

This data is packed in 2 bytes in the profibus side. The first data is in bit number 0 and the second in bit number 1 and so forth.

5.4.8.4. Analog output

When you have opened a template with an analog output into the main window, you can configure its settings that are shown in the Template info field as follows:

1. Select the signal you want to configure and click **Edit**, or double-click on the signal.
2. A dialog is opened where you can modify the settings of that specific signal, see Fig. 5.4.8.4.-1. The fields that you cannot configure are dimmed.
3. To save the new settings, click **OK**. To cancel, click **Cancel** to discard all changes.

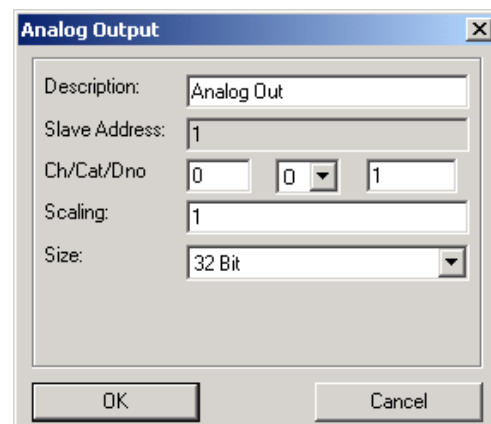

A050368

Fig. 5.4.8.4.-1 Analog Output configuration dialog

The definitions of the analog output signal settings are the following:

Description	Signal name
Slave Address	The slave address of the protection relay or unit
Ch/Cat/Dno	The Channel (Ch), Category (Cat), and the Data number (Dno) where the specific Analog values are written to the SPA slave device.
Scaling	Scaling factor, for details see Section 5.4.8.7. Scaling of messages.

Installation and Commissioning Manual

Size	16 bit or 32 bit that defines the size of the Analog field in the Profibus DP, the default is 32 bit. This affects the total template output bytes.
In Use	The In Use flag indicates if the parameter was found in the connected SPA slave device during the initialization phase. In the Template info field the in Use flag is marked with number 1. A zero indicates that the parameter was not found. For details, see Section 4.7. In Use flags.
Priority check box	By selecting the Priority check box, you can define if the message should be polled more frequently than other messages. This is indicated by the letter P (prioritized) after the signal name in the Template info field. If the signal is not prioritized, the letter N (normal) can be seen in the Template info field. The default is N. For details, see Section 5.4.8. Template info.

5.4.8.5. Digital output

When you have opened a template with a digital output into the main window you can configure its settings that are shown in the Template info field as follows:

1. Select the signal you want to configure and click **Edit**, or double-click on the signal.
2. A dialog is opened where you can modify the settings of that specific signal, see Fig. 5.4.8.5.-1. The fields that you cannot configure are dimmed.
3. To save the new settings, click **OK**. To cancel, click **Cancel** to discard all the changes.

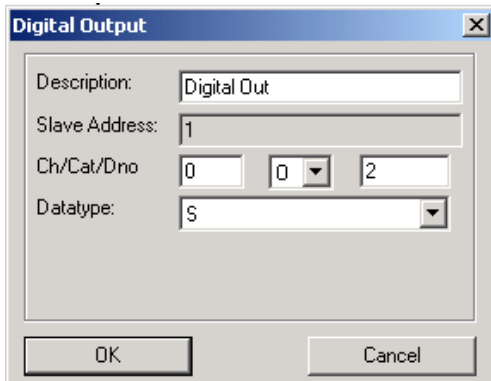

A050350

Fig. 5.4.8.5.-1 Digital Output configuration dialog

The definitions of the digital output signal settings are the following:

Description	Signal name
Slave Address	The slave address of the protection relay or unit
Ch/Cat/Dno	The Channel (Ch), Category (Cat), and the Data number (Dno) where the specific Digital values are written to the SPA slave device.
Datatype	Defines if the SPA data is treated as a single-bit (S), double-bit (D) or a hexadecimal value (H).

In Use	The In Use flag indicates if the parameter was found in the connected SPA slave device during the initialization phase. In the Template info Field the In Use flag is marked with number 1. An unchecked box indicates that the parameter was not found. For details, see Section 4.7. In Use flags.
Priority check box	By selecting the Priority check-box, you can define if the message should be polled more frequently than other messages. This is indicated by the letter P (prioritized) after the signal name in the Template info field. If the signal is not prioritized the letter N (normal) can be seen in the Template info field. The default is N. For details, see Section 5.4.8. Template info.

5.4.8.6.

Indirect SPA Messages

Indirect SPA messages are acyclic messages that are not polled cyclically but can be used at any time. Acyclic messages are primarily intended to be used for parametrization and other non-continuous operations.



For indirect SPA messages to work properly, a Profibus master with DP version 1 must be used. This is because indirect SPA messages use the acyclic properties available only from version 1 onwards.

It is possible to add and remove indirect SPA messages by clicking the buttons in the indirect SPA message field in the main window, see Fig. 5.3.-1 number 7.

To add a new indirect SPA message, click the **Add** button. An empty variable row will be added in the indirect SPA message list. To edit the new indirect SPA message, select the new message in the list and click the **Edit** button, or double-click on the signal. A dialog where you can edit the settings pops up. The PCT assigns the message number for the indirect SPA message. This message number is used when configuring the Profibus master. The numbering starts from one and it follows the row numbers of the indirect SPA messages in the PCT.

You can also remove an indirect SPA message. Select the SPA message that you want to remove and click the **Remove** button.

To configure the settings of the indirect SPA messages, do as follows:

1. Select the signal you want to configure and click the **Edit** button, or double-click on the signal.
2. A dialog is opened where you can modify the settings of that specific signal, see Fig. 5.4.8.6.-1. The fields that you cannot configure are dimmed.
3. To save the new settings, click **OK**. To cancel, click **Cancel** to discard all the changes.

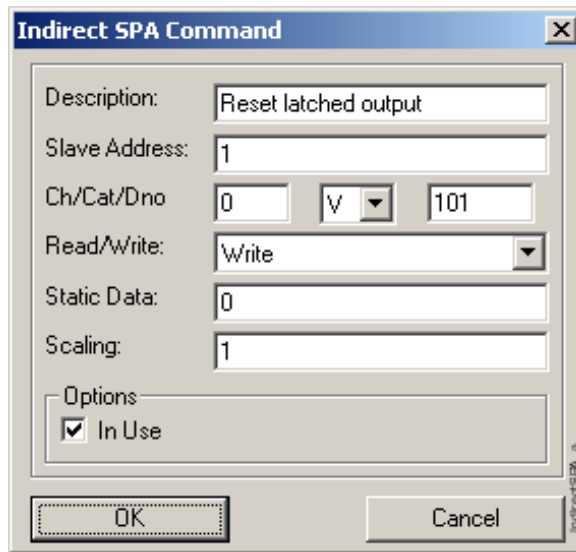

Fig. 5.4.8.6.-1 Indirect SPA Message dialog

The definitions of the Indirect SPA message settings are the following:

Description	Signal name
Slave Address	The slave address of the protection relay or unit
Ch/Cat/Dno	The Channel (Ch), Category (Cat), and the Data number (Dno) where the specific Analog values are read/written on the SPA slave device. It must be verified that the parameter (Ch/Cat/Dno) in question exists in the SPA slave.
Read/Write	Identifies the request either W (write) or to R (read). The default value is R (read).
StaticData	(Optional) Data that is assigned the write command. There can be many SPA write messages that always use the same static value for example reset commands. This is only valid for write commands. If the message is defined to be R (read), then the StaticData is ignored.
Scaling	Scaling factor, for details see Section 5.4.8.7. Scaling of messages.
In Use	The In Use flag indicates if the parameter was found in the connected SPA slave device during the initialization phase. In the Template info field the In Use flag is marked with number 1. An unselected check-box indicates that the parameter was not found. For details, see Section 4.7. In Use flags.

5.4.8.7. Scaling of messages

Scaling of values may be necessary in order to get the precision of the values that the application requires. It may also be necessary to take scaling into consideration when commands are sent from the application.

There are two means to scale values in the gateway: global scaling and parameter specific scaling.

- Global scaling is done using the decimal place setting.
- Parameter specific scaling is done for analog values in the parameter specific properties dialog.

To calculate the value on the SPA bus, use the following formula:

$$\text{SPA_Value} = \frac{\text{Profibus_Value}}{(\text{parameter scaling} \times 10^{\text{Decimal_place}})}$$

To calculate the value on Profibus, use the following formula:

$$\text{Profibus_Value} = \text{SPA_Value} \times (\text{parameter scaling} \times 10^{\text{Decimal_place}})$$

The scaling factor is configurable when you select a signal of Indirect SPA message type and click **Edit**. The default value is 1.



Scaling must be taken into account also in the Profibus master application when used in the gateway, otherwise the master will handle scaled values instead of the real values.

5.4.9.

Message priority

SPA Poll messages can be handled as prioritized messages, that is, they are polled more frequently than other messages. The priority of SPA Poll messages can be configured individually for each analog/digital input/output or a whole slave can be prioritized.

Normally, all messages will be polled once every cycle regardless their priority. Between each normal poll, a prioritized poll can be issued using a priority cycle. The priority cycle only handles prioritized messages.

Messages can be prioritized as follows:

1. Select a signal and click the **Edit** button, or double-click on the signal.
2. A signal configuration dialog will pop up, in which you can select the Priority check-box in the left corner.
3. Click **OK**. The priority will be indicated in the template signal list with the letter P directly after the name of the signal. The letter N indicates normal priority, that is the signal is not prioritized. The default is N.

To prioritize a whole slave, select **Slave > Prioritize > On**.



It is better to prioritize a group of signals, for example, an entire slave or all slaves' / single slaves' digital inputs or analog inputs.

6. Standard configuration templates

6.1. Module status word

When operating in cyclic mode, that is, polling values from the protection relay, the module status word is transferred first in every message frame. The content of this word includes the status of some important running conditions, as defined in Table 6.1.-1.

Table 6.1.-1 Module status word description

Bit	Name	Description
0	Gateway mode	0 = Gateway operates in configuration mode. 1 = Gateway operates in application mode.
1	Configuration status	0 = The configuration file is working properly. 1 = The configuration file has errors (CRC, incorrect setup detected...) or does not exist (first start-up). For more information about the errors, see Section 8.4. Troubleshooting.
2	Hardware status	0 = The gateway is working properly. 1 = Hardware failures have been detected in the gateway.
3	SPA On-line (0) / Off-line (1)	0 = Gateway is on-line. It communicates with the SPA slave device. 1 = Gateway is off-line. Communication with the SPA slave device is disconnected.
4	SPA initialized (0)/ Initializing (1)	0 = Configuration file has been initialized. 1 = Configuration file is being initialized.
5	Configuration Warning	0 = No errors detected during initialization of the configuration file. 1 = Errors were found while initializing the configuration file. The warnings do NOT prevent the gateway from its operation state. Or, errors were found when the gateway tried to read SPA parameter that does not exist in the SPA slave. Check template documentation for the list of required functions in the SPA slave. The configuration warning bit is also raised upon a NACK message from the IED connected to the SPA-ZC302. The IED sends the NACK message, for example, if the control operation access is denied or an interlock situation. The configuration warning bit is not tied to a certain write message operation, therefore a successful write operation does not clear it. Reset of the configuration warning bit is not supported.
6	-	Not defined
7	-	Reserved
8	-	Reserved
9	-	Reserved
10	Indirect SPA pending	This bit informs the state of message flow between the gateway and SPA slave. When using the Indirect SPA messaging interface, this bit informs that the current message is pending and waits for a SPA response.
11	Indirect SPA complete	This bit informs the state of message flow between the gateway and SPA slave. When using the Indirect SPA message interface, this bit informs that the current pending message is complete.
12	Indirect SPA error	This bit informs the state of message flow between the gateway and SPA slave. When using the Indirect SPA message interface, this bit informs that the current message response contains errors.
13	Reserved	Bit used internally
14	SPA slave lost events	The status information of SPA slave devices indicates that events have been lost.
15	SPA slave event buffer overflow	Overflow. The status information of SPA slave devices indicates that an event buffer overflow has occurred.



The process data is valid when the gateway mode bit indicates application mode and SPA initializing bit is zero. Bit 3 must be zero (SPA On-line). If bit 5 indicates a configuration warning, then some of the data is invalid (unavailable). The unavailable items are reported with 0xF in the Profibus message. For valid process data, the SPA device status (IRF) information should also indicate no errors and slave status bit must be set ("1") for all the connected slaves. For more information, see Section 6.2. Slave status word.

6.2.

Slave status word

A slave's status word contains information about a maximum of 16 slaves. The first bit represents the slave with the lowest SPA address. The second bit is the slave with the second lowest address and so on. When the bit indicates 1, it means that the slave is online and the data on profibus side is valid. In case of an event based data updating, the device's SPA event mask has to be open. This error situation cannot be seen from the slave status bit.



The device's SPA event mask has to be open when updating event based data. This error situation cannot be seen from the slave status bit. If the parameters cannot be read from the SPA device, the value 0xFF, 0xFFFF or 0xFFFFFFFF according to the size of the data.

6.3.

Usage and purpose of SPA protocol events

When a protection relay detects an exception in normal operation (such as a trip or a restart of the relay) an event is generated and buffered inside the protection relay, providing that the event mask has been set correctly. Events are identified on the SPA protocol as E-codes, for example E50, which indicates that the protection relay has restarted. These events can later be uploaded from the relay to a SPA protocol master. See the protection relay manual for details on triggers events.

The SPA-ZC 302 gateway contains a SPA master that is capable of uploading this information from the protection relay. When the polling of events feature is enabled in the configuration template, the SPA master transfers the information to the Profibus master as a changed state of the parameter in question.



If multiple SPA connections from a protection relay are used, the event based data should be read only to one of the connected SPA masters. The Profibus-DPV1/SPA gateway contains such a SPA master.

The event codes are also used in the gateway in a different way, such as to update the measurement value of a binary input value. This feature is used in some standard configurations concerning mainly start and trip information, and breaker state.

A single-bit and a double-bit indication uses SPA protocol events as presented in Fig. 6.3.-1 .

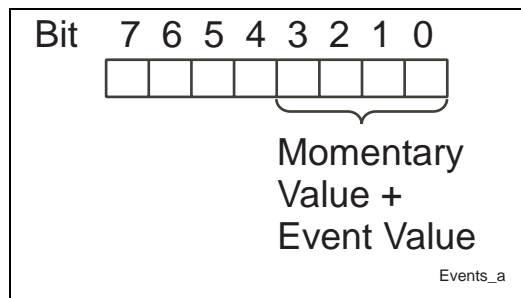

Fig. 6.3.-1 SPA protocol events structure

When the gateway goes on-line, the momentary value of a parameter is read into the low nibble of the digital input. After this, the momentary value is updated when a SPA protocol event is generated in the protection relay. This means that the Profibus master always will have a valid momentary value for the parameter in question.



If the data is not updated based on events, it is possible to lose information, if a very fast double transition occurs between two SPA poll cycles. If events are used, then all transitions are caught, but they may be delayed.

It is probable that the loss of a fast double transition is related to the speed of Profibus DP. The faster the Profibus DP master polls its slaves, the less likely it is that a double transition is lost.

The events that are supported in the standard configuration templates are listed in the SPA code column of the cyclic signal table, directly after the SPA code that provides the gateway with the initial momentary value.

6.4.

Using indirect SPA messages

It is only possible to use indirect SPA messages in Profibus DP masters that support Profibus DP version 1 or higher. The master must also be able to address a specific slot and index. Some masters may require special configuration to meet the requirements when using indirect SPA messages. It is the acyclic property defined for version 1 that enables this kind of functionality. Because the indirect SPA messages are not connected to any poll cycle, they can be used to define own SPA messages that can be read or written any time by the Profibus DP version 1 master configuration.

Typical SPA messages are defined for some of the configurations. Nothing prevents the user from adding new, changing existing or even removing SPA messages from the configuration. Therefore, the indirect SPA messages defined in the configurations shall be considered to be a best guess of what might be needed when using that particular configuration.

Indirect SPA messages are defined using the PCT, see Section 5.4.8.6. Indirect SPA Messages. In the PCT, the indirect SPA message gets an index that is later used to refer to that specific parameter. A maximum of 127 messages can be defined.

Installation and Commissioning Manual

After the configuration is downloaded and the gateway has started, the defined indirect SPA message is used by writing its assigned number (8 bit) to Query slot 15 Index 5. The value of the 7th bit in the number shall be changed in order to trigger the gateway to send the message to the SPA slave.

Example:

Assume that there is a defined indirect SPA message with number 1. When writing value 0x81 to Query slot 15 Index 5, the gateway sends the message to the SPA slave. Next time the value 0x1 shall be written into slot 15 Index 5 in order to trigger the operation.

Setting the static data to zero in the configuration enables the use of Indirect SPA value, which means that the gateway uses the value in slot 15 index 6 in the SPA command, see Section 5.4.8.6. Indirect SPA Messages.

Write the value (32 bit) to Query slot 15 Index 6 before triggering the sending. Keep in mind that this value (and the static data value) is scaled in the same way as the cyclic parameters values, see Section 5.4.8.7. Scaling of messages, for example, if the decimal place is 1 and scaling value 1 is scaled to 0.1 on SPA bus.

It is recommended to check the module status after indirect SPA messages to ensure that the message response indicates no errors.

The response to the sent indirect SPA message can be read from response slot 17.

The data is set up as follows:

SPA request status can be found in slot 17 index 0. The length of the SPA status is two bytes. See the status code in Table 6.4.-1.

If the response from the SPA device contains data, for example the value of the current measurement, it can be found in slot 17 index 1. The length of the data is four bytes.

The status word in response slot 17 can have one of the following values, see Table 6.4.-1

Table 6.4.-1 Indirect SPA messages error table

Description Error	Code	Description
No Error	0x1000	No error has occurred
SPA Slave-Checksum Error	0x8000	SPA message contains a checksum error
SPA Slave-Busy	0x8001	SPA slave is busy
SPA Slave-Input Buffer Overflow	0x8002	SPA input buffer overflowed
SPA Slave-Msg too Complicated	0x8003	Message from the master is too complicated for the slave
SPA Slave-Reserved High Lvl	0x8004	Reserved for higher level of communication
SPA Slave-Syntax Error	0x8005	Syntax Error. Incorrect message type or category etc.
SPA Slave-Missing data	0x8006	Slave does not contain all requested data in the message
SPA Slave-Impossible Address	0x8007	Addressed data is impossible to write or read
SPA Slave-Not Validated	0x8008	Data in write message not validated

Table 6.4.-1 Indirect SPA messages error table (Continued)

SPA Slave-Unknown NACK	0x8009	Undefined negative acknowledgement
SPA GW-Checksum Error	0x8100	SPA slave response contained a checksum error
SPA GW-Input Buffer Overflowed	0x8102	SPA slave response too big for GW input buffer
SPA GW-Msg too Complicated	0x8103	SPA slave response too complicated for the gateway
SPA GW-Syntax Error	0x8105	SPA slave response can not be interpreted by gateway
SPA GW-Missing data	0x8106	SPA slave response is incomplete
SPA Network Timeout	0x8200	SPA message has timed out
SPA Network Response Pause	0x8201	SPA Response Pause time is violated
SPA Slave off-line	0x8202	SPA Slave is off-line why the message is ignored

6.5.**GSD file**

For a Profibus device to be fully compliant with the Profibus specification, the vendor must provide a GSD (Geräte Stamm Datei, Basic Profibus Device Description) file for the Profibus slave device. A GSD file contains basic data about the device, such as communication parameters, that make configuration and commissioning of the device easier.

6.5.1.**GSD file and standard configurations**

The relation between the GSD file and the standard configuration templates is logical. That is, there is no strict connection between the two entities. The main issue is, however, that the size of the configuration of the gateway must match the size of the module in use. This is because the module defines the size of the data block that is copied from the Profibus slave to the master in each poll cycle, and if this size does not match, the communication will not work properly.

6.5.2.**Using GSD file**

When you have selected, completed and downloaded the configuration of the gateway, the Profibus master should be configured to accept the gateway device as a part of the Profibus network.

Because different Profibus masters are configured by using different procedures, it is strongly advised to consult the user documentation for the master in use. However, all the masters are equipped with a mechanism for use with the GSD file, which is provided by the vendor of the slave device. There are also masters using offset calculations.

When the GSD file has been inserted into the system configuration, you can select a number of modules for use. Which module should be used for which standard configuration is documented in the GSD module section in each of the standard configuration template descriptions.

6.6.**Standard configuration templates**

There are available ready-made standard configuration templates designed for the use of SPA-ZC 302 gateways. The templates can be combined to build up a multislave configuration as long as they stay below the total size limit. For more information about the templates, refer to the SPA-ZC 302 Standard Configuration Templates manual. The manual is included in the SPA-ZC 302 configuration CD.

7. Technical data

7.1. Interfaces

Profibus DP version 1 interface

- RS-485 twisted pair
- 9-pin female D-connector

SPA bus interface

- RS-232, RS-485 or TTL levels
- 9-pin female D-connector

7.2. Power supply

SPA-ZC 302

- Input voltage: 110 V...240 V AC/DC
- Output voltage (conf. with DIP switch 1.5): +8 V DC unregulated from pin 9 (RS-485, TTL)
- Supply current consumption: <80 mA

Table 7.2.-1 Environmental conditions

Specified ambient service temperature range	-10...+55°C
Transport and storage temperature range	-40...+70°C
Maximum relative humidity (without condensation)	95%

Table 7.2.-2 Environmental tests

Dry heat test according to IEC 60068-2-2	+55°C
Dry cold test according to IEC 60068-2-1	-10°C
Damp heat test according to IEC 60068-2-30	RH > 93%, 55°C, 6 cycles
Degree of protection by enclosure of the device case according to IEC 60529	IP20

Table 7.2.-3 Electromagnetic compatibility tests

The EMC immunity test level fulfils the requirements specified below		
1 MHz burst disturbance test, class III, IEC 60255-22-1	common mode	2.5 kV
	differential mode	1.0 kV
Electrostatic discharge test, class III, IEC 61000-4-2 and IEC60255-22-2	for contact discharge	6 kV
	for air discharge	8 kV

Installation and Commissioning Manual

Table 7.2.-3 Electromagnetic compatibility tests (Continued)

Radio frequency interference test	conducted, common mode IEC 61000-4-6 and IEC 60255-22-6	10 V (rms), f = 150 kHz...80 MHz
	radiated, amplitude- modulated IEC 61000-4-3 and IEC 60255-22-3	10 V/m (rms), f = 80...1000 MHz
	radiated, pulse-modulated ENV 50204	10 V/m, f = 900 MHz
Fast transient disturbance test IEC 60255-22-4 and IEC 60255-22-5	power supply	4 kV
Surge immunity test IEC 61000-4-5	power supply	4 kV, line to earth 2 kV, line to line
Power frequency (50 Hz) magnetic field IEC 61000-4-8	300 A/m continuous	
Voltage dips and short interruptions IEC 61000-4-11	30%, 10 ms 60%, 100 ms 60%, 1000 ms >90%, 5000 ms	
Electromagnetic emission tests EN 55011 and IEC 60255-25	conducted RF emission (mains terminal)	EN 55011, class A IEC 60255-25
	radiated RF emission	EN 55011, class A IEC 60255-25
CE approval	Complies with the EMC directive 89/336/EEC and the LV directive 73/23/EEC	

Table 7.2.-4 Dimensions and weight

Type	Dimensions [mm]	Weight [g]
SPA-ZC 302	197 x 104 x 50	530

Installation and Commissioning Manual

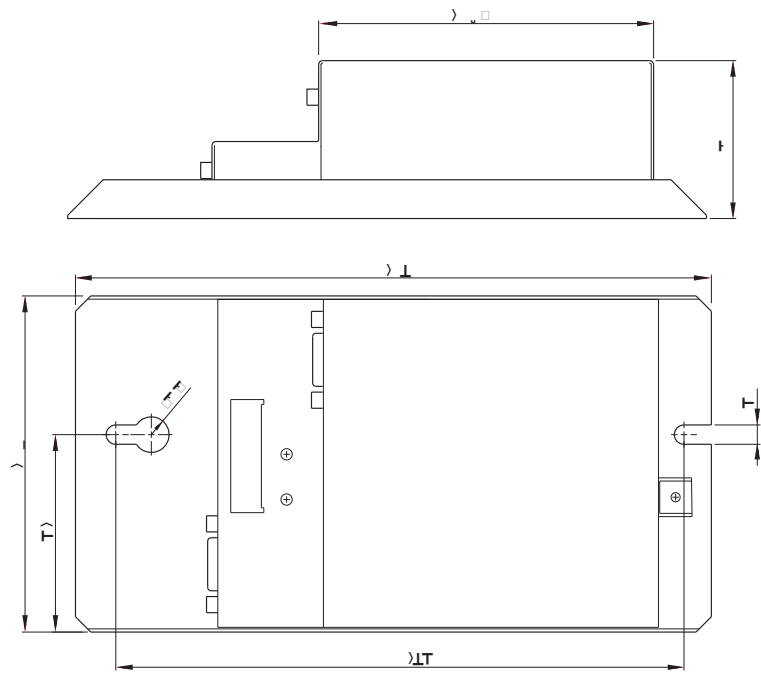

302_dim_a

Fig. 7.2.-1 Dimensions of the SPA-ZC 302 module

8. Maintenance and service

8.1. General about service

If the SPA-ZC 302 module or part of it is found to be faulty, the normal service operation is to replace the entire module. For more details, refer to the ordering information.

8.2. Custom configurations

There may arise situations when no existing configuration fulfils the requirements of the application. In these cases, our customer support organization offers service by creating new standard configuration templates. The new configuration is then included with the next release of the product CD as a standard configuration, if it is also relevant to other users.

To be able to sufficiently prepare a service request, the following procedure should be followed:

1. Look in the relevant protection relay manuals for SPA parameters that contain information that is necessary for the application.
2. Contact customer support at ABB OY, Substation Automation and send in the information.
3. Customer support will make an offer, based on the provided information.
4. If the offer is accepted, the configuration will be built, tested and documented.

The following data is required:

- What protection relay is to be supported (for example: REM543R or several relays)
- SPA parameter data of the signals wanted (for example: 48O6)
- Description of the signal (For example: Cooling time in seconds)
- The order of the parameters, in case it is important

8.2.1. Limitations

There are some limitations that affect the way the standard configurations are made:

- 244 bytes of input, 244 bytes of output or totally 416 bytes of data bandwidth is available for input or output. The reason for the limitations is limits in the Profibus protocol specification and the implementation of it. Consequence of this limitation is that it is possible to transfer only a certain amount of cyclical parameter data over Profibus from each device. It can be assumed, as a guideline, that each analog data need four bytes, and each digital data one byte of data bandwidth.



When building the multislave configurations, the total template size value in PCT is limited to 240. A warning message is displayed in PCT if the limit is exceeded.

- The larger the number of signals, the longer will the update cycle be.

8.3. Self-diagnosis

8.3.1. LED indicators

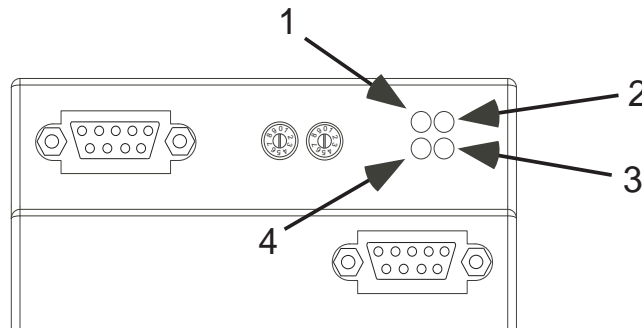

ProfibusLED_a

Fig. 8.3.1.-1 Profibus-DPV1 LED indicators

See Table 8.3.1-1 for the description of the Profibus LED indicators pictured in Fig. 8.3.1.-1 .

Table 8.3.1-1 Profibus-DPV1 LED indicator

LED no	Description	Colour	State	Indicates
1	Acyclic Traffic	Green	On	A DPV1 request is currently being executed.
			Off	No Power to the module. No DPV1 request is currently being executed.
2	Fieldbus ON-line	Green	On	Bus is on-line and data exchange is possible.
			Off	No power to the module. Bus is not on-line.
			Flashing 1 Hz	Clear mode. The Profibus master has initiated a clear command.
3	Fieldbus OFF-line	Red	On	Bus is off-line.
			Off	No power to the module. Bus is NOT off-line
4	Fieldbus Diagnostics	Red	Off	No power to the module. No diagnostics is present.
			Flashing 1 Hz	Error in configuration data.
			Flashing 2 Hz	Error in parameter data.
			Flashing 4 Hz	Error in initialising of the Profibus communication ASIC.

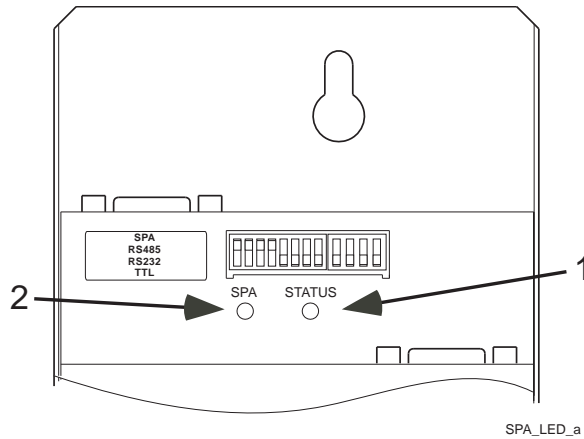

Fig. 8.3.1.-2 SPA LED indicators

See Table 8.3.1-2 for the description of the Profibus LED indicators pictured in Fig. 8.3.1.-2 .

Table 8.3.1-2 SPA LED indicator description

LED no	Description	Colour	State	Indicates
1	Module Status	Green	Off	No power to the gateway.
			Flashing 1 Hz	Power ON. Running in configuration mode.
		Red	On	Power ON. Running in application mode.
			Flashing 1 Hz	Configuration error. Test of the onboard configuration file failed (gateway not operational).
2	SPA Communication Status	Green	On	Hardware error (Flash, SRAM, ABS).
			Flashing irregular	SPA/Cfg Communication Idle.
		Red	On	Serial Message Transmission when in Application mode (Until SPA goes on-line) and when in configuration mode.
			Flashing irregular	SPA Network on-line.
			On	Serial message reception error when in both application and configuration mode (framing, parity, CRC error etc.).
	On	No SPA slave attached or cabling problem (SPA Network Offline).		

8.4. Troubleshooting

When troubleshooting the gateway, first check the LED indicators described in Section 8.3. Self-diagnosis. If there is a LED flashing, a coarse error can be located through the flashing pattern of the LED.

8.4.1. Gateway diagnostics

Detailed information about the error may be available in the diagnostics that can be uploaded from the gateway. For details about uploading, see Section 5.4.2.3. Upload diagnostics.

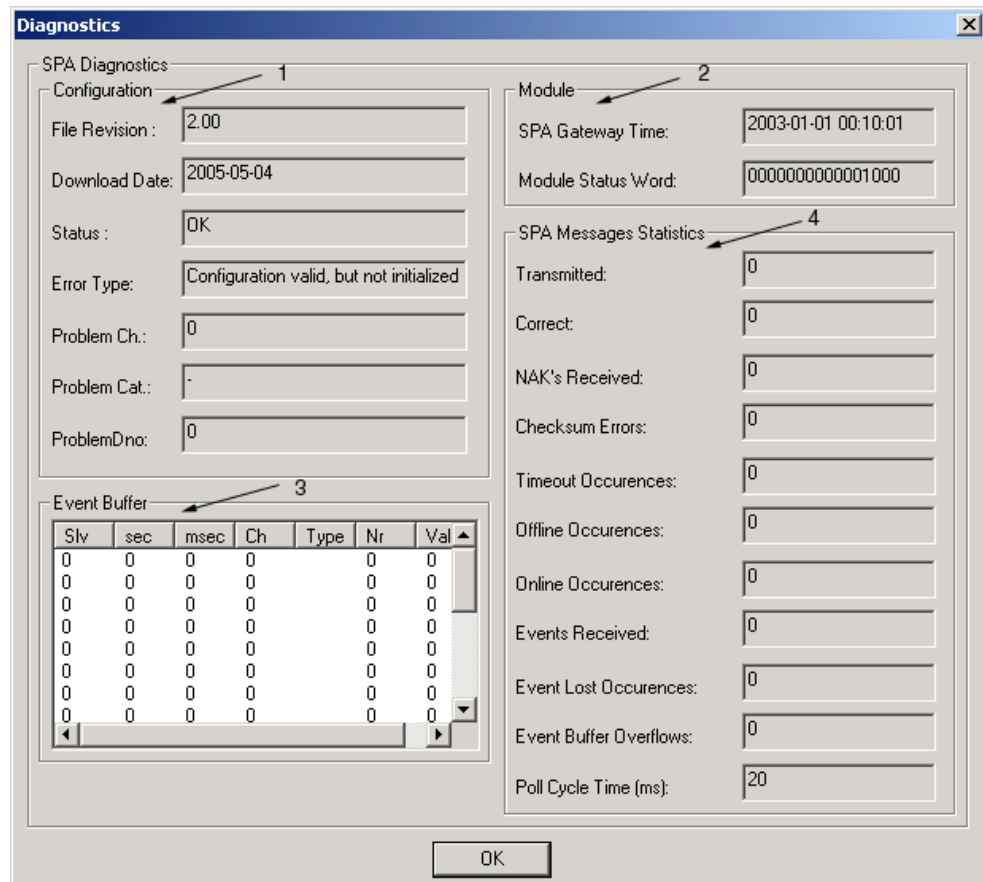

A050354

Fig. 8.4.1.-1 Diagnostics dialog

The Diagnostics dialog is divided in four different sections: 1. Configuration, 2. Module, 3. Event Buffer and 4. SPA message statistics:

1. Configuration

File revision	Revision of the configuration file used
Download date	Date when the configuration has been downloaded
Status	Status of the configuration
Error type	An error type number if an error was detected at initialization of the device, see Table 8.4.1-1 .
Problem ch	SPA channel number of the configuration problem
Problem cat	SPA category of the configuration problem
Problem Dno	SPA parameter name of the configuration problem

Table 8.4.1-1 Configuration error types

Error Type	Description
Configuration OK	No problem detected in the configuration file.
Configuration Empty	The gateway was not able to locate any configuration.
Configuration valid, but not initialised	Check that the relay is connected and SPA addresses and communication speed in the relay are correct.
CRC Failure	The gateway was not able to verify the CRC of the configuration file.
Unsupported Baudrate	The gateway was not able to use the configured baudrate.
Unsupported Reply Timeout	The gateway was not able to use the configured Reply Timeout.
Unsupported Idle Time	The gateway is not able to use the configured Idle Time.
Unsupported Retry Count	The gateway is not able to use the configured Retry Count.
Unsupported PDP Default Address	The gateway is not able to use the configured Profibus Default Address.
Unsupported Decimal Place	The gateway is not able to use the configured Decimal Place.
Analog Input Error ¹⁾	Error in one of the Analog Input settings.
Digital Input Error ¹⁾	Error in one of the Digital Input settings.
Analog Output Error ¹⁾	Error in one of the Analog Output settings.
Digital Output Error ¹⁾	Error in one of the Digital Output settings.
Indirect SPA Error ¹⁾	Error in one of the Indirect SPA settings.

¹⁾These error codes are followed by more data in the diagnostics fields, such as SPA Channel, SPA Type and SPA Dno (Parameter No) for easier location of the trouble spot. For all other error situations, these fields will be set to zero.

2. Event Buffer section

Slv	Slave address from which the event has been read
Sec	Seconds when the event occurred
Msec	Milliseconds when the event occurred
Ch	Communication channel on which the event occurred
Type	Type of event that occurred
Nr	Event number
Val	Value of the event

3. Module section

SPA Gateway Time	Set time in the gateway
Module Status Word	Status of the gateway. This word is sent to the master as the first word in each input data block. The definition of the bits is described in Section 6.1. Module status word.

4. SPA messages statistics section

Transmitted	Number of SPA messages transmitted
Correct	Number of correctly formed SPA messages

Installation and Commissioning Manual

NACK's received	Number of NACK (Negative Acknowledgement) responses received from the SPA slave
Checksum errors	Number of checksum errors detected
Timeout occurrences	Number of timeout occurrences. The timeout occurrences counter is increased when the SPA slave does not answer to the gateway in the time specified in "SPA reply timeout". If you notice this error, try to increase the SPA reply timeout.
Off-line occurrences	Number of times communication between the SPA slave and the gateway has been lost
On-line occurrences	Number of times communication between the SPA slave and the gateway has been established
Events received	Number of events received
Event lost occurrences	Number of event lost occurrences. The event lost counter is increased when the protection relay reports that it has lost events for example due to a reset.
Event buffer overflows	Number of times the event buffer has overflowed. The event buffer overflow counter is increased when the protection relay reports that an event buffer overflow has occurred. If this occurs often, check the protection relays event mask settings first, and if no errors can be found there, try to decrease the global poll interval setting, see Section 5.4.7.1. SPA configuration.
Poll cycle time	Time span in which the polled SPA parameters are updated.

8.4.2.**Communication errors between SPA-ZC 302 and SPA slave**

If there are indications of communication errors between SPA-ZC 302 and the SPA slave, you can try to change the "SPA Reply Timeout", "SPA Idle Time" and "SPA Com Retry Count" parameters. The default parameters should work without any problems with most of the SPA slave devices. If you notice SPA communication failures when checking the Diagnostic dialog of PCT, then following guidelines should be followed when changing the parameters:

- Usually, the SPA communication errors are caused by the hardware. Therefore, start by checking all cabling and hardware settings of the SPA slave and SPA-ZC 302 device. If several slaves are connected, check the SPA loop and that the connected converters are set correctly.
- If hardware setting or cabling errors are not found, try to increase "SPA Reply Timeout" and "SPA Idle Time" into their maximum values.
- If the communication is now working properly:
- Search for the minimum value for the "SPA Idle Time". A value below default value is not recommended.
- When the minimum value for the "SPA Idle Time" is found, you can repeat the same process for the SPA Reply Timeout. A value below default value is not recommended.

Installation and Commissioning Manual

- If the communication is still not working, try to increase the "SPA Com Retry Count". This might be an indication of a hardware error in the cable or in the devices. Contact your ABB representative.



ABB Oy

Distribution Automation

P.O. Box 699

FI-65101 Vaasa

FINLAND

Tel. +358 10 22 11

Fax. +358 10 224 1094

www.abb.com/substationautomation