

SPAC 310 C and SPAC 312 C Feeder Terminal

User's manual and Technical description

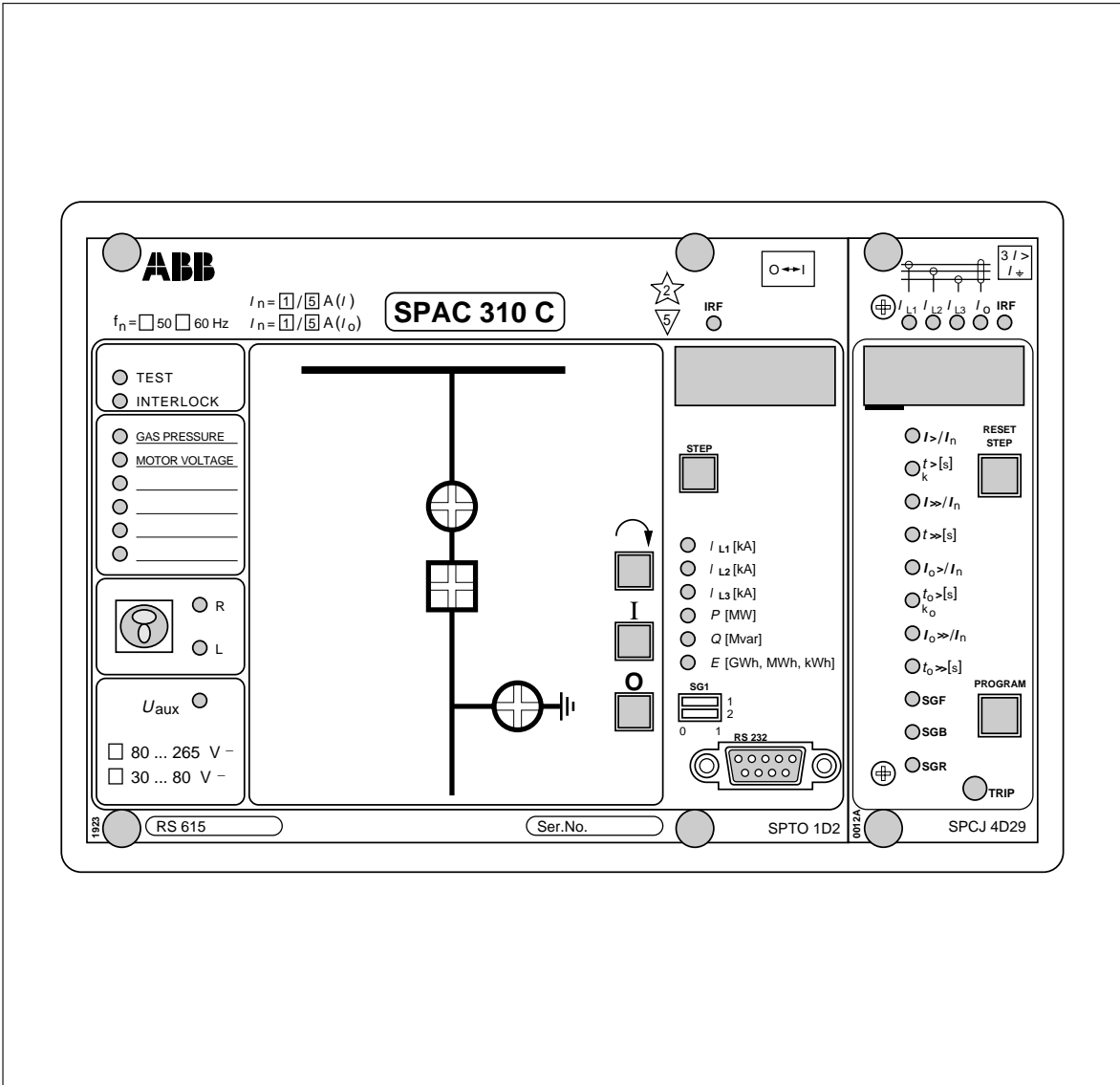

Data subject to change without notice

Contents

Features	3
Area of application	3
Description of function	5
Design	5
Protection functions	7
Control functions	8
Measurement functions	9
Serial communication	9
Auxiliary power supply	9
Application	10
Mounting and dimension drawings	10
Connection diagram	11
Intermodular control signal exchange	13
Terminals and wiring	15
Start-up	16
Technical data (<i>modified 2002-05</i>)	17
Exchange and spare parts	21
Maintenance and repairs	21
Order information	21

The user's manual for the feeder terminal SPAC 310 C/SPAC 312 C is composed of the following partial manuals:

General description	1MRS 750747-MUM EN
Control module SPTO 1D2	1MRS 750748-MUM EN
General characteristics of D-type relay modules	1MRS 750066-MUM EN
Combined overcurrent and earth-fault relay module SPCJ 4D29	1MRS 750119-MUM EN

Features	Complete field unit with definite or inverse time overcurrent and earth-fault protection	Six user-programmable binary inputs with local and remote indication
	Complete control module for local and remote control of one object	Phase current, energy, active and reactive power measurement and indication
	Local and remote status indication of maximum three objects and local or remote control of one object	Serial interface for remote control and data interchange
	User-programmable feeder level interlocking system for preventing not permitted switching operations	Continuous self-supervision for maximum reliability

Area of application

The feeder terminals SPAC 310 C and SPAC 312 C are designed to be used as cubicle-based protection and remote control interface units. In addition to protection, control and measurement functions the unit is provided with the data communication properties needed for the control of the feeder. Connection to higher level substation control equipment is carried out via a fibre-optic serial bus.

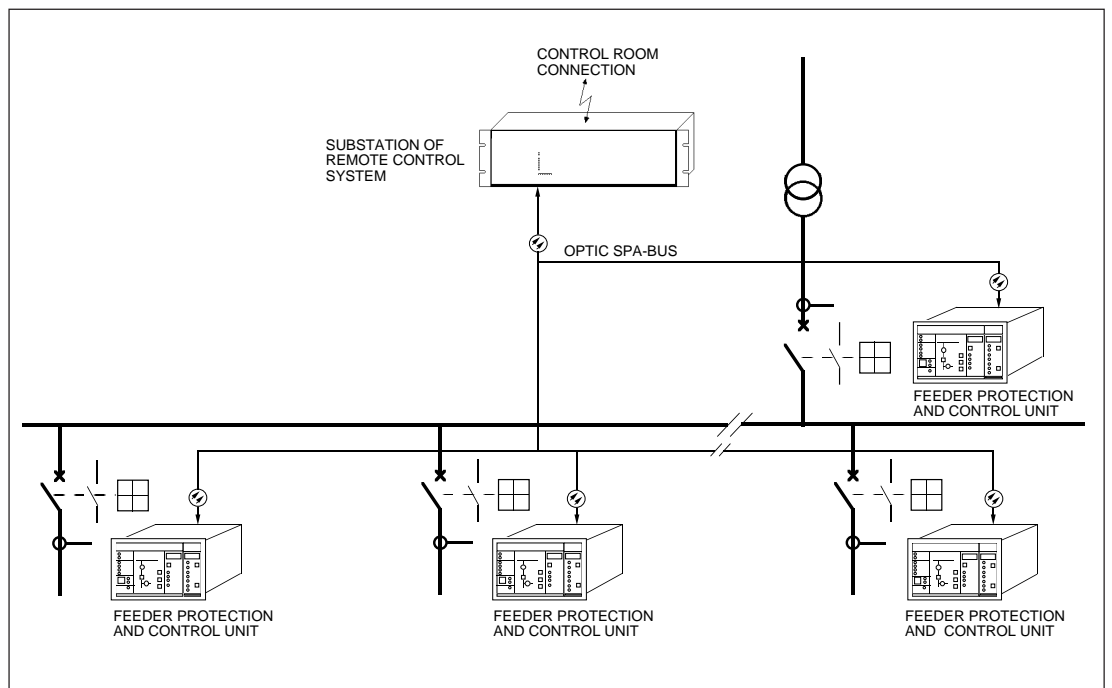

Fig. 1. Distributed protection and control system based on feeder terminals SPAC 310 C or SPAC 312 C.

The only difference between the types SPAC 310 C and SPAC 312 C is the rated current of the earth-fault protection. For SPAC 310 C it is 1 A and 5 A and for SPAC 312 C 0.2 A and 1 A.

The unit is intended for the selective short-circuit and earth-fault protection of radial feeders in solidly earthed, resistance earthed or impedance earthed power systems. The short-circuit and earth-fault protection is accomplished by a combined overcurrent and earth-fault module.

The control module included in the unit indicates locally by means of LED indicators the status of maximum three disconnectors or circuit breakers. Further the module allows status information from the circuit breaker and the disconnectors to be transmitted to the remote control system, and one object, e.g. a circuit breaker, to be opened and closed via the remote

control system. The status information and the control signals are transmitted over the serial bus. Also local control of one object is possible by using the push-buttons on the front panel of the control module.

The control module measures and indicates the three phase currents. The active and reactive power are measured over two mA-inputs. External measuring transducers are needed. Energy can be calculated on the basis of the measured power values or by using one input as an energy pulse counter. The measured values can be indicated locally and remotely as scaled values.

The overcurrent protection module also measures and records the three phase currents and the neutral current. All the measured and recorded values are indicated locally and can be transmitted to the remote control system over the SPA bus.

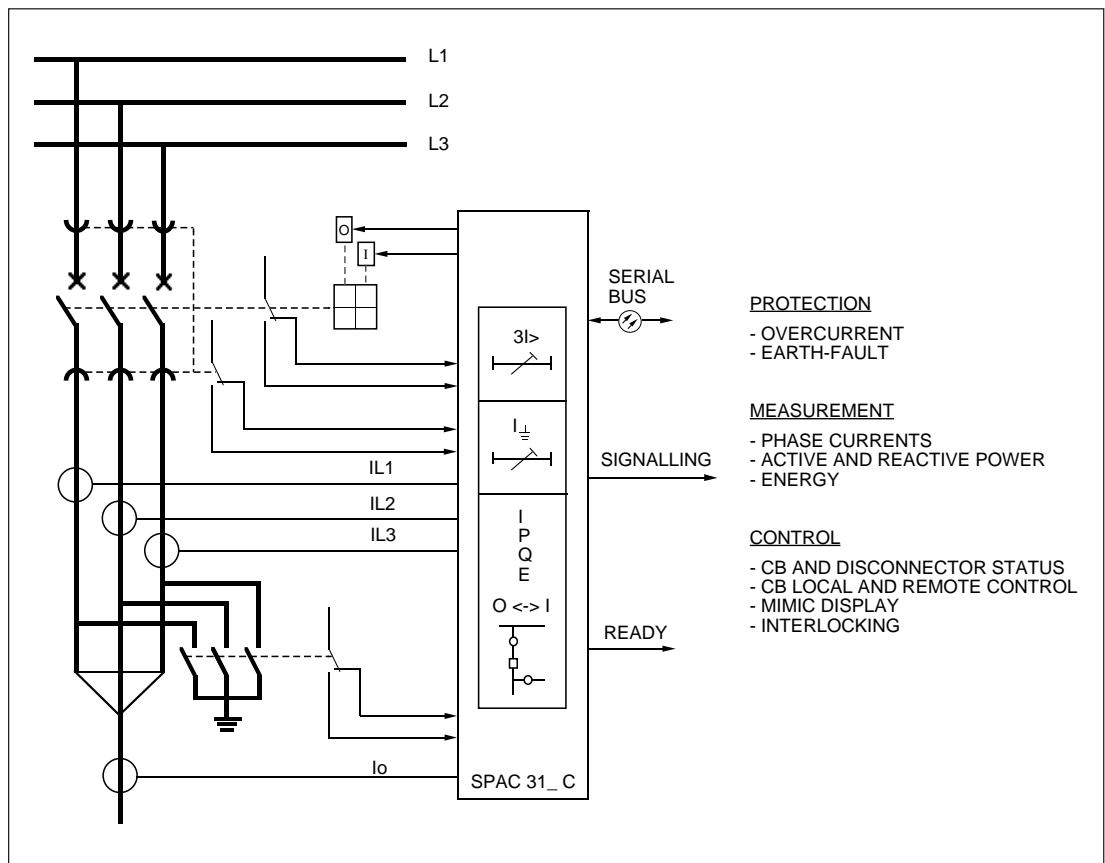

Fig. 2. Basic functions of the feeder terminal SPAC 310 C or SPAC 312 C

Description of function

The feeder terminal includes five modules. Their function is explained in the following table.

Design

Module	Function
Protection module SPCJ 4D29	Overcurrent and earth-fault protection. Measures, records and indicates locally and remotely three phase currents and neutral current.
Control module SPTO 1D2	Reads and indicates locally and remotely status data of maximum three disconnectors or circuit breakers. Reads and indicates locally and remotely maximum six external binary signals. Measures and indicates locally and remotely three phase currents, active and reactive power and energy. Transfers local or remote open and close commands for one circuit breaker.
I/O module SPTR 3B12 or SPTR 3B13	Includes 12 optically isolated binary inputs, trip and close output contacts and IRF alarm contact.
Power supply module SPGU 240A1 or SPGU 48B2	Forms the internal voltages required by the other modules.
Energizing input module SPTE 4F1 (SPAC 310 C) or SPTE 4F2 (SPAC 312 C)	Includes matching transformers and their tuning electronics for three phase currents and neutral current. Includes the motherboard with three signalling output contacts and electronics for the mA inputs.

The combined overcurrent and earth-fault protection module SPCJ 4D29 is a Euro-size (100 x 160 mm) withdrawable module.

The control module type SPTO 1D2 is also withdrawable. The control module includes two PC boards; a CPU board and a front PC board which are joined together. The I/O board SPTR 3B_ is located behind the front PC board and is fastened by screws to the front PC board.

The power supply module SPGU 240 A1 or SPGU 48 B2 is located behind the front PC board of the control module and can be withdrawn from the case after the control module has been removed.

The protection module SPCJ 4D29 is fastened to the case by means of two finger screws and the control module SPTO 1D2 by means of four finger screws. These modules are removed by

undoing the finger screws and pulling the modules out of the subrack. To be able to remove the I/O module the control module has to be withdrawn from the case and the screws of the I/O module have to be removed from the front PC board.

The energizing input module SPTE 4F1 or SPTE 4F2 is located behind the front PC board of the control module on the left side of the case. A screw terminal block, the rear plate and the mother PC board are connected to the energizing input module.

The mother PC board contains the card connectors for the plug-in modules, the detachable multi-pole connector strips of the inputs and outputs, the tuning resistors of the secondary burden of the matching transformers and the electronics of the signal outputs and mA inputs.

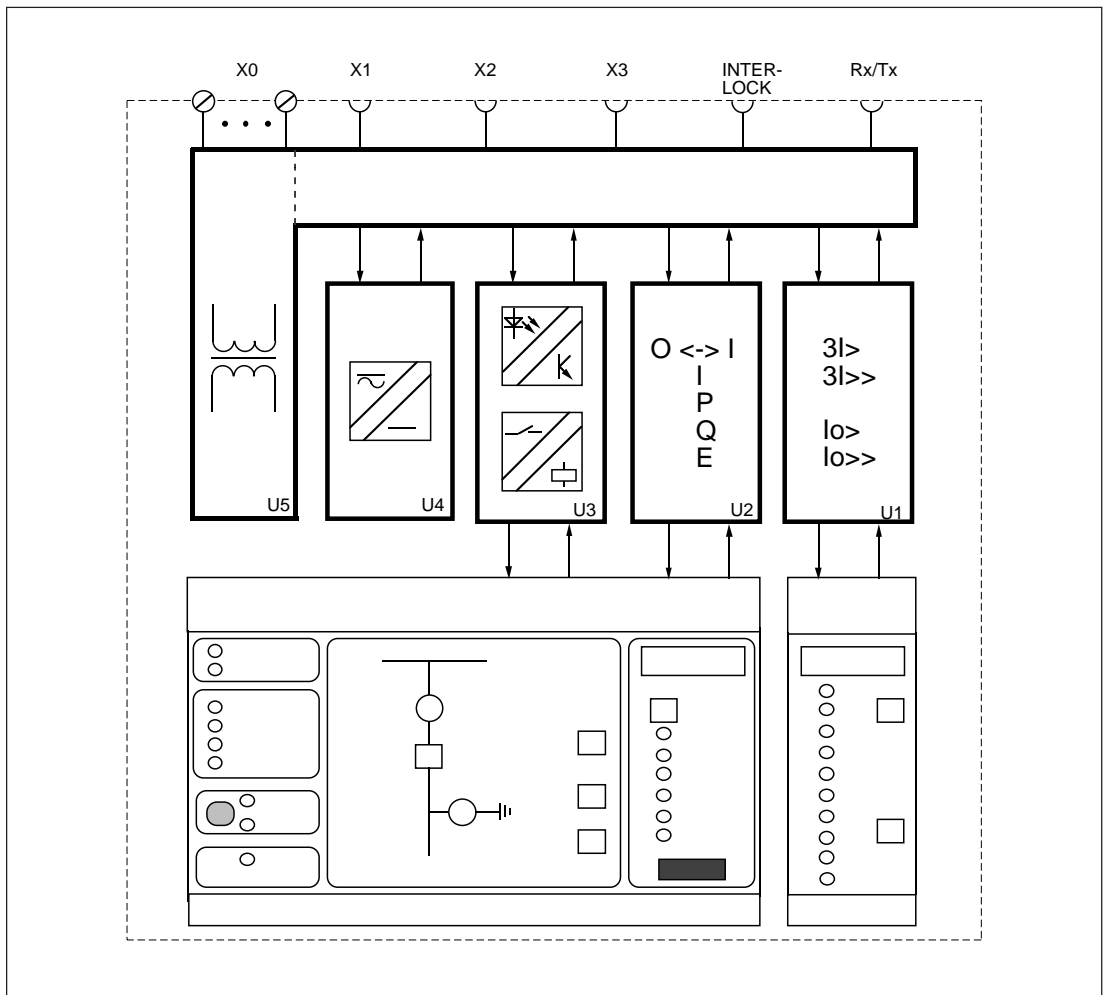

Fig. 3. Block diagram for the feeder terminals SPAC 310 C and SPAC 312 C

U1	Overcurrent and earth-fault protection module SPCJ 4D29
U2	Control module SPTO 1D2
U3	I/O module SPTR 3B12 or SPTR 3B13 for digital inputs and contact outputs
U4	Power supply module SPGU 240 A1 or SPGU 48 B2
U5	Energizing input module and motherboard SPTE 4F1 or SPTE 4F2
X0	Screw terminals
X1...X3	Multi-pole connectors
Rx/Tx	Serial communication port

The case is made of extruded aluminium profile, the collar is of cast aluminium and the cover of clear UV-stabilized polycarbonate. The collar is provided with a rubber gasket providing an IP 54 degree of protection between the case and the mounting panel.

The cover of the case contains two push-buttons which can be used for scanning through the displays of the protection and control modules.

To reset the operation indicators of the protection and to use the local control push-buttons of the control module, the cover has to be opened.

The cover is locked with two finger screws. The rubber gasket between the cover and the collar ensures that the cover, too, fulfills the IP 54 requirements. The opening angle of the cover is 145°.

<p>Protection functions</p> <p><i>Phase overcurrent protection</i></p>	<p>The overcurrent protection of the combined overcurrent and earth-fault protection module SPCJ 4D29 has two operating stages, a low-set stage and a high-set stage. The low-set stage may be given definite time or inverse definite minimum time (IDMT) characteristic, whereas the high-set stage can be given definite time characteristic only.</p> <p>The module measures the phase currents of the feeder to be protected. When one phase current exceeds the setting value of the low-set overcurrent stage, the overcurrent stage starts, simulta-</p>	<p>neously starting the corresponding timing circuit. When the set operating time has elapsed, a tripping command is delivered. Correspondingly the high-set overcurrent stage starts when the relevant setting value is exceeded. It starts its timing circuit and performs tripping when the set time has elapsed.</p> <p>The tripping of the low-set or the high-set overcurrent protection can be blocked by connecting a voltage to one binary input, input channel 8.</p>
<p><i>Neutral overcurrent protection</i></p>	<p>The combined overcurrent and earth-fault protection module SPCJ 4D29 also includes a two-stage non-directional earth-fault protection. The earth-fault protection measures the neutral current and operates in the same way as the overcurrent protection.</p>	<p>The low-set stage earth-fault protection can be given definite time or inverse definite minimum time characteristic, while the high-set earth-fault stage can be given definite time characteristic only. The tripping of the earth-fault stages can be blocked by connecting a voltage to input channel 8.</p>
<p><i>Contact outputs of the protection</i></p>	<p>The tripping signal of the feeder terminal is wired to the OPEN output. The feeder terminal has four signalling contacts, one of which is the common internal relay failure (IRF) output.</p>	<p>Three signalling outputs, SIGNAL 1...3, can be used to indicate the starting or tripping of the protection, see chapter "Intermodular control signal exchange".</p>

<p>Control functions</p> <p><i>General</i></p>	<p>The control module SPTO 1D2 is used for reading the status information of circuit-breakers and disconnectors. The module indicates the status locally by means of LED indicators and transfers the information to station level equipment via the SPA bus. The status of maximum three objects can be indicated.</p>	<p>The control module is also used for controlling one object e.g. a circuit-breaker, locally or with the opening or closing commands received over the SPA bus.</p> <p>In addition to status information the control module can read other binary data, indicate the information locally and transfer it to station level equipment. Maximum six external binary signals can be wired to SPAC.</p>
<p><i>Input channels 1...3</i></p>	<p>The control module uses input channels 1...3 to read the status information of circuit breakers and disconnectors. Each of these channels is formed by two binary inputs, one input is used for reading the open status and the other one for reading the closed status of an object. This means that the status information must be wired to SPAC as four-pole information.</p>	<p>The front panel of SPTO 1D2 has a 4x4 matrix of status indication LEDs. Simultaneously, maximum three of these LEDs can be used for status indication. The circuit breaker/disconnector configuration indicated by these LEDs is freely programmable by the user.</p> <p>One of the objects whose status is read via input channels 1...3 can be controlled. This is done by using the outputs OPEN and CLOSE.</p>
<p><i>Input channels 4...9 and 10...13</i></p>	<p>The control module can be used for reading six external and four internal binary signals. The external signals, channels 4...9, can be single contact data wired from the bay and the internal signals, channels 10...13, are startings and trippings of the protection.</p> <p>The input signal type for channels 4...13 can be programmed to be active at high state, i.e. normally open contact, or active at low state, i.e. normally closed contact.</p>	<p>The front panel has a local LED indication for the external input channels 4...9. The red LED is lit when the input is active.</p> <p>The input channels 4...13 can be used to control the outputs OPEN, CLOSE and SIGNAL 1...3. If the input channel becomes active the programmed OPEN or CLOSE output gives a pulse. The output SIGNAL 1...3 is active as long as the input is active.</p>
<p><i>Interlocking</i></p>	<p>The control module includes a feeder-based interlocking which is freely programmable by the user. When writing an interlocking program the user defines when it is allowed to give an open or close pulse for the controlled object. When an opening or closing command is given the interlocking is checked and after that the command is executed or canceled.</p>	<p>The interlocking can be programmed to be depending on the status of the four-pole input channels 1...3 and the status of input channels 4...13. The tripping signals of the protection are not influenced by the interlocking.</p> <p>To simplify start-up the feeder terminal is provided with default interlocking schemes. A default interlocking scheme is always related to a default circuit breaker / disconnector configuration.</p>
<p><i>Conditional direct output control</i></p>	<p>Normally the OPEN and CLOSE outputs are controlled by giving an open or close command. In the conditional direct output control all the outputs, i.e. OPEN, CLOSE and SIGNAL 1...3,</p>	<p>can be controlled without using an open or close command. The outputs are activated depending on a programmed logic and the status of input channels 1...3 and 4...13.</p>

Measurement functions	<p>Both the control module SPTO 1D2 and the combined overcurrent and earth-fault module SPCJ 4D29 measures analog signals.</p> <p>The combined overcurrent and earth-fault module measures the three phase currents and the neutral current. The module indicates the current values locally and can transmit the data via the SPA bus to the remote control system. The protection module always indicates the measured values as a multiple of the rated current of the relay.</p> <p>The control module measures five analog signals; three phase currents and active and reactive power. The ratio of the primary current transformers can be programmed into the control module. In that way it is possible to indicate the primary values of the phase currents.</p>	<p>The control module measures the active and reactive power via two mA inputs. External measuring transducers have to be used. The mA signals are scaled to actual MWs and Mvars and the data is indicated locally and can be transmitted to the remote control system.</p> <p>Active energy is measured in two ways; either by calculating the value on the basis of the measured power or by using input channel 7 as a pulse counter. In the latter case an external energy meter with pulse output is needed. In both cases the amount of measured energy is displayed locally and can be transmitted to the remote control system.</p>
Serial communication	<p>The feeder terminal includes two serial communication ports, one on the front panel and the other on the rear panel.</p> <p>The 9-pin RS 232 connection on the front panel is to be used for setting the feeder terminal and programming the CB/disconnector configura-</p>	<p>tion, the feeder oriented interlocking and other parameters from a terminal or a PC.</p> <p>The 9-pin RS 485 connection on the rear panel is used for connecting the feeder terminal to the SPA bus. An optional bus connection module type SPA-ZC 17 or SPA-ZC 21 is required.</p>
Auxiliary power supply	<p>For the operation of the feeder protection and control unit a secured auxiliary voltage supply is needed. The power supply module SPGU__ forms the voltages required by the measuring relay module, the control module and the input/output module.</p> <p>The power supply module is a transformer connected, i.e. galvanically isolated primary and secondary side, flyback-type DC/DC converter.</p>	<p>The primary side of the power supply module is protected with a fuse, F1, located on the PCB of the module. The fuse size is 1 A (slow).</p> <p>A green LED indicator Uaux on the front panel is lit when the power supply module is in operation. There are two versions of power supply modules available. The secondary sides are identical, only the input voltage range is different. The input voltage range is marked on the front panel of the control module.</p>

Application

Mounting and dimension drawings

The feeder terminal SPAC is housed in a normally flush-mounted case. The unit is fixed to the mounting panel by means of four mounting brackets.

A surface mounting case SPA-ZX 316 is also available.

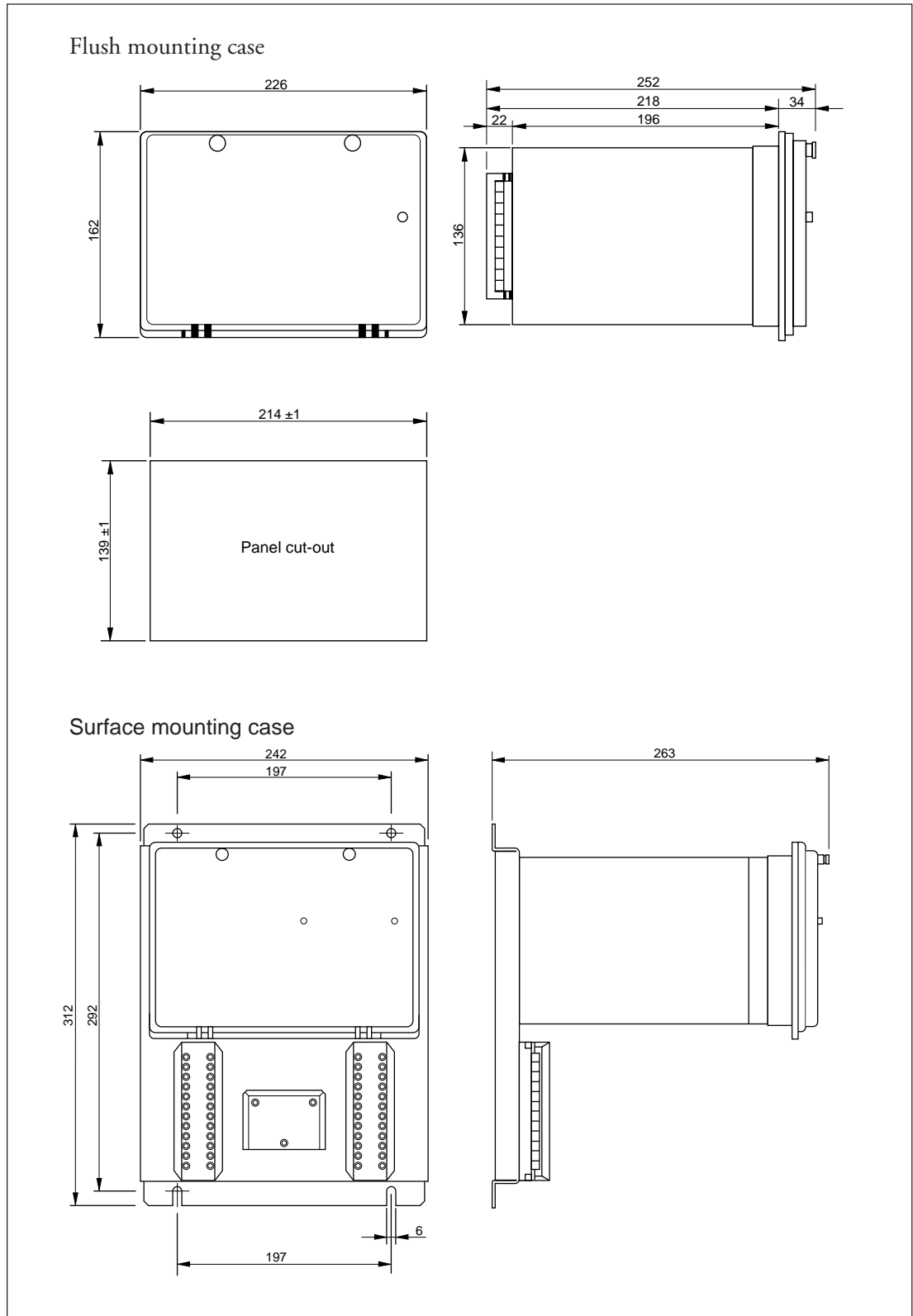

Fig. 4. Mounting and dimension drawings of feeder terminals SPAC 310 C and SPAC 312 C

Connection diagram

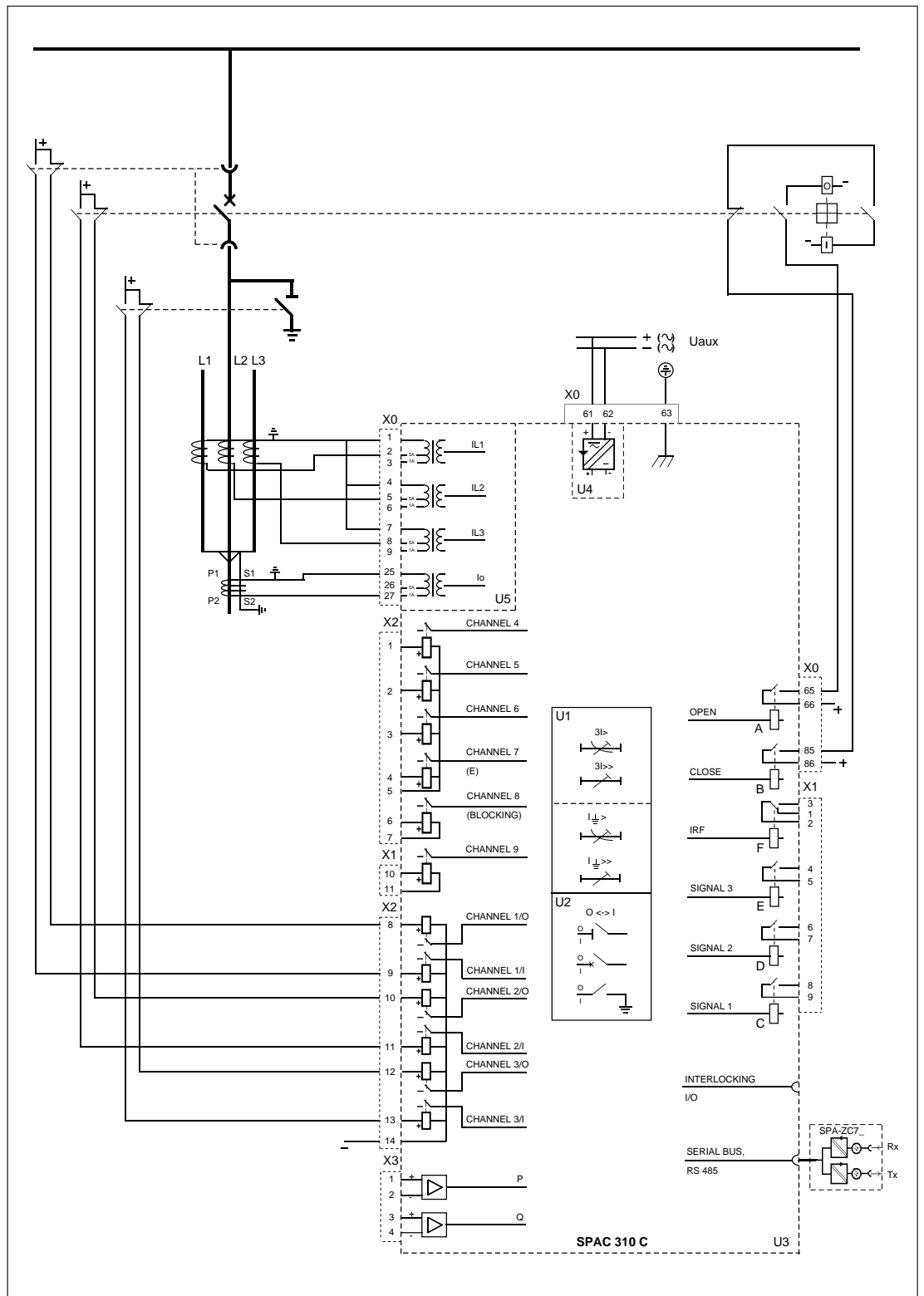

Fig. 5. Connection diagram for SPAC 310 C. In SPAC 312 C the rated neutral current for terminal numbers 25-26 is 1 A and for terminal numbers 25-27 0.2 A

Terminal numbers:

Terminal block	Terminal number	Function
X0	1-2	Current I_{L1} , 5A
	1-3	Current I_{L1} , 1A
	4-5	Current I_{L2} , 5A
	4-6	Current I_{L2} , 1A
	7-8	Current I_{L3} , 5A
	7-9	Current I_{L3} , 1A
	25-26	Neutral current I_0 , 5A in SPAC 310 C or 1A in SPAC 312 C
	25-27	Neutral current I_0 , 1A in SPAC 310 C or 0.2A in SPAC 312 C
	61-62	Auxiliary power supply. Positive voltage should be connected to terminal 61
	63	Protective earth
X0	65-66	Open output, as a default also $I_>$, $I_{>>}$, $I_{0>}$ and $I_{0>>}$ tripping signal
	85-86	Close output
X1	1-2-3	Self-supervision (IRF) signalling output. When auxiliary power is connected and the device is operating properly the contact 2-3 is closed
	4-5	Signal output 3. E.g. $I_>$ alarm, $I_{>>}$ alarm, $I_{0>}$ alarm, $I_{0>>}$ alarm (programmable), as a default alarm for $I_>$ or $I_{>>}$ trip
	6-7	Signal output 2. E.g. $I_>$ start or alarm, $I_{>>}$ start or alarm, $I_{0>}$ start or alarm, $I_{0>>}$ start or alarm (programmable), as a default no signal is connected
	8-9	Signal output 1. E.g. $I_>$ start, $I_{>>}$ start, $I_{0>}$ start, $I_{0>>}$ start (programmable), as a default $I_>$ start
X2	10-11	Input channel 9
	1-5	Input channel 4
	2-5	Input channel 5
	3-5	Input channel 6
	4-5	Input channel 7 or energy pulse counter
	6-7	Input channel 8 or blocking for protection
	8-14	Input channel 1, open status. E.g. when a circuit breaker is open there must be a voltage connected to this input
	9-14	Input channel 1, closed status. E.g. when a circuit breaker is closed there must be a voltage connected to this input
	10-14	Input channel 2, open status
	11-14	Input channel 2, closed status
X2	12-14	Input channel 3, open status
	13-14	Input channel 3, closed status
X3	1-2	mA input for the measurement of active power
	3-4	mA input for the measurement of reactive power

The channel numbers mentioned above are those used when programming the control module SPTO 1D2. When programming the control module the following codes are used for the outputs:

Output	Terminal numbers	Output code for interlocking	Output code for Conditional Direct Output Control
OPEN	X0/65-66	20	220
CLOSE	X0/85-86	21	221
SIGNAL 1	X1/8-9	22	22
SIGNAL 2	X1/6-7	23	23
SIGNAL 3	X1/4-5	24	24

Intermodular control signal exchange

The initial factory settings of the feeder terminal may have to be changed in different applications. The scheme below illustrates how the

input and output signals can be programmed to obtain the required functions for the unit.

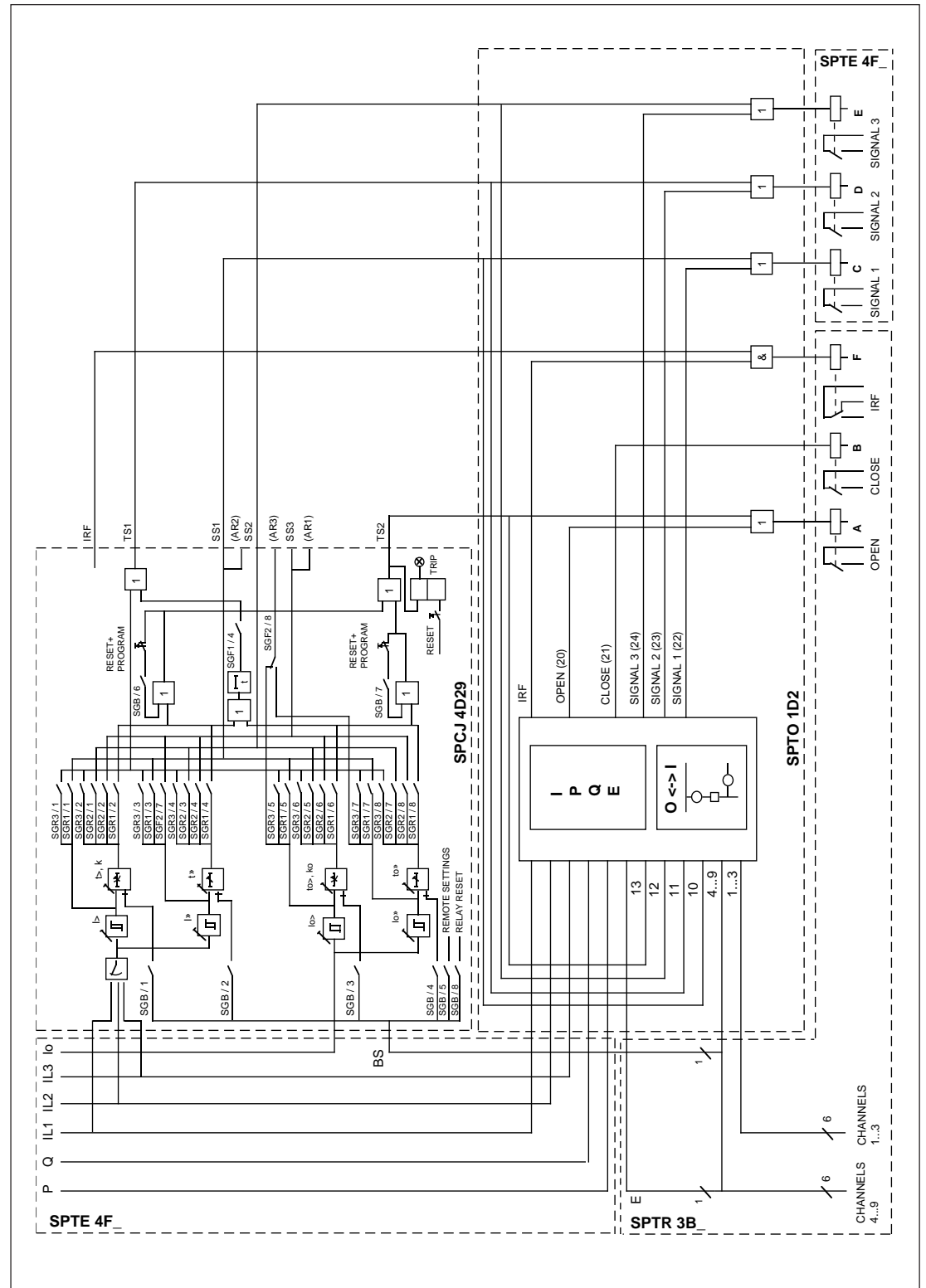

Fig. 6. Intermodular control signals of SPAC 310 C and SPAC 312 C

The following table gives the default values of the switches shown in Fig. 6.

Switch	Function	Default value
SGF1/4	Selection of breaker failure protection	0
SGF2/7	No function in SPAC 310 C or SPAC 312 C	0
SGF2/8	No function in SPAC 310 C or SPAC 312 C	0
SGB/1	Forms from a voltage connected to input 8 a blocking signal for the tripping of the I> stage	0
SGB/2	Forms from a voltage connected to input 8 a blocking signal for the tripping of the I>> stage	0
SGB/3	Forms from a voltage connected to input 8 a blocking signal for the tripping of the I ₀ > stage	0
SGB/4	Forms from a voltage connected to input 8 a blocking signal for the tripping of the I ₀ >> stage	0
SGB/5	Enables switching from protection main settings to second settings by applying a voltage to input 8	0
SGB/6	Selects a latching feature for the trip signal TS2 at overcurrent faults	0
SGB/7	Selects a latching feature for the trip signal TS2 at earth faults	0
SGB/8	Enables a remote reset of latched output relays and memorized values by means of an external control voltage on input 8	0
SGR1/1	Links the starting signal of stage I> to SIGNAL 1 output	1
SGR1/2	Links the tripping signal of stage I> to OPEN output	1
SGR1/3	Links the starting signal of stage I>> to SIGNAL 1 output	0
SGR1/4	Links the tripping signal of stage I>> to OPEN output	1
SGR1/5	Links the starting signal of stage I ₀ > to SIGNAL 1 output	0
SGR1/6	Links the tripping signal of stage I ₀ > to OPEN output	1
SGR1/7	Links the starting signal of stage I ₀ >> to SIGNAL 1 output	0
SGR1/8	Links the tripping signal of stage I ₀ >> to OPEN output	1
SGR2/1	Links the tripping signal of stage I> to SIGNAL 3 output	1
SGR2/2	No function in SPAC 310 C or SPAC 312 C	0
SGR2/3	Links the tripping signal of stage I>> to SIGNAL 3 output	1
SGR2/4	No function in SPAC 310 C or SPAC 312 C	0
SGR2/5	Links the tripping signal of stage I ₀ > to SIGNAL 3 output	0
SGR2/6	No function in SPAC 310 C or SPAC 312 C	1
SGR2/7	Links the tripping signal of stage I ₀ >> to SIGNAL 3 output	0
SGR2/8	No function in SPAC 310 C or SPAC 312 C	1
SGR3/1	Links the starting signal of stage I> to SIGNAL 2 output	0
SGR3/2	Links the tripping signal of stage I> to SIGNAL 2 output	0
SGR3/3	Links the starting signal of stage I>> to SIGNAL 2 output	0
SGR3/4	Links the tripping signal of stage I>> to SIGNAL 2 output	0
SGR3/5	Links the starting signal of stage I ₀ > to SIGNAL 2 output	0
SGR3/6	Links the tripping signal of stage I ₀ > to SIGNAL 2 output	0
SGR3/7	Links the starting signal of stage I ₀ >> to SIGNAL 2 output	0
SGR3/8	Links the tripping signal of stage I ₀ >> to SIGNAL 2 output	0

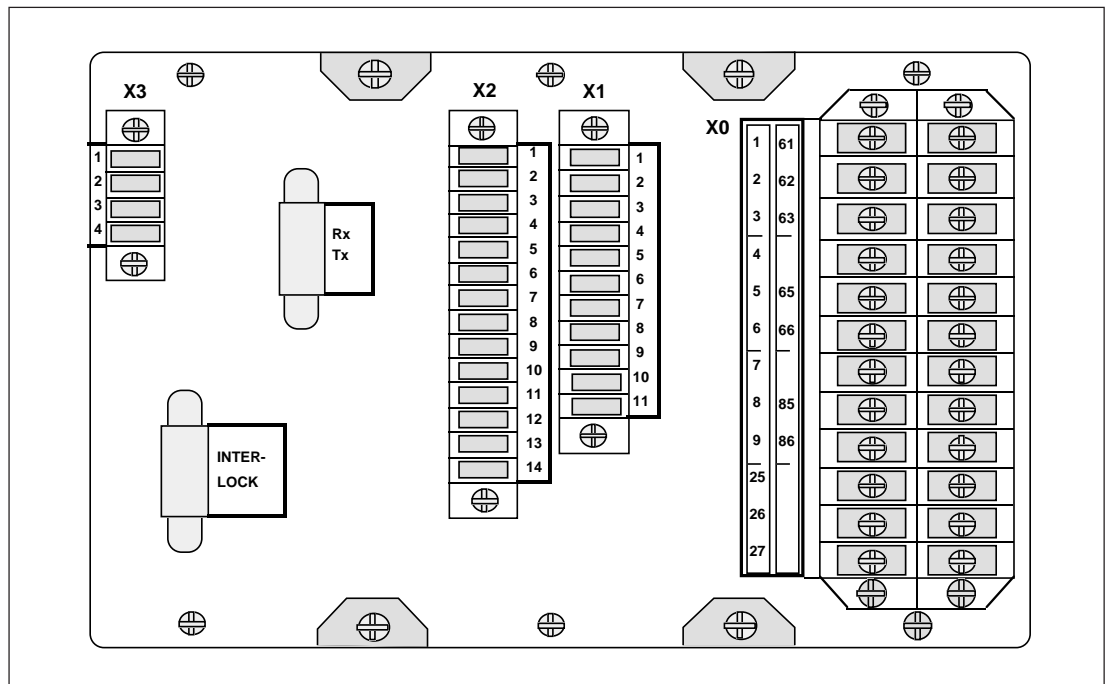

Fig. 7. Rear view of feeder terminal SPAC 310 C and SPAC 312 C

All external conductors are connected to the terminal blocks on the rear panel. Terminal block X0 consists of fixed screw terminals fastened to the energizing input module. The connectors X1...X3 are detachable multi-pole connector strips with screw terminals.

The male part of the multi-pole connector strips are fastened to the mother PC board. The female parts with accessories are delivered together with the feeder terminal. The position of the female connector part can be secured by means of fixing accessories and screws on the end of the connector.

The measuring signal inputs, auxiliary voltage supply and OPEN and CLOSE contact outputs are connected to the terminal block X0. Each terminal is dimensioned for one or two max. 2.5 mm² wires. The wires are fastened with M 3.5 Phillips cross slotted screws (recess type H). The terminal block is protected by a transparent shroud.

The signalling contact outputs are connected to the multi-pole connector X1. The input channels 1...3 and 4...8 are connected via connector X2. Input channel 9 is wired via connector X1 and the two mA inputs via connector X3. One max. 1.5 mm² wire or two max. 0.75 mm² wires can be connected to one screw terminal.

The rear panel of the feeder terminal is provided with a serial interface for the SPA bus (RS 485). Two types of bus connection modules are available. The bus connection module type SPA-ZC 21 is fitted directly to the 9-pin D-type subminiature connector. The bus connection module SPA-ZC 17 includes a connection cable with a D-type connector. Thus the connection module can be installed at a suitable place in the switchgear cubicle within the reach of the connection cable.

The 9-pole D-type subminiature connector INTERLOCK is reserved for future use.

Start-up

The start-up should be done according to the following instructions. Checks 1 and 2 have to be performed before the auxiliary power supply is switched on.

1. Voltage ranges of the binary inputs

Before connecting a voltage to input channels 1...9, check the operative voltage range of the inputs. The voltage range, U_{aux} , is marked on the front panel of the control module.

2. Auxiliary supply voltage

Before switching on the auxiliary supply voltage check the input voltage range of the power supply module. The voltage range, U_{aux} , is marked on the front panel of the control module.

3. Programming of the control module SPTO 1D2

All the non-volatile EEPROM parameters have been given default values after factory testing. The default configuration and interlocking 1 has been selected. The default parameters are explained in the manual of the control module SPTO 1D2.

If the default parameters are not satisfactory, the following parameters can be programmed:

- Configuration; default or user defined configuration
- Interlocking; default or user defined interlocking
- OPEN and CLOSE outputs; pulse lengths
- Measurements; ratio of primary current transformers, settings for active and reactive power measurement, settings for energy measurement
- Input channels 4...13; settings for polarity and output activation
- Event reporting; event masks, event delay times

The programming can be done via the front panel RS 232 connection or the rear panel RS 485 connection by using a SPA protocol. Instructions are given in the manual of the control module SPTO 1D2.

4. Settings of the protection module SPCJ 4D29

At the factory default setting values have been programmed for the protection module. All the current and time settings are at their minimum values. The default checksum values for the switchgroups are:

Switchgroup	Σ
SGF1	0
SGF2	0
SGB	0
SGR1	171
SGR2	165
SGR3	0

All tripping signals $I>$, $I>>$, $I_0>$ and $I_0>>$ are connected to the signal TS2, which controls the OPEN output. The signal SS1 which controls the SIGNAL 1 output indicates starting of the $I>$ stage. The signal SS2 which controls the SIGNAL 3 output indicates tripping of the $I>$ and $I>>$ stages

These values can be changed manually from the push-buttons on the front panel of the protection module. Also the RS 232 connection on the front panel of the control module or the RS 485 connection on the rear panel of SPAC can be used for changing the settings of the protection. In that case SPA protocol commands are used.

The exact meaning of the switchgroups is explained in the manual of the overcurrent protection module SPCJ 4D29.

Technical data
(modified 2002-05)

Energizing inputs

Rated current I_n			
- overcurrent unit of SPAC 310 C and SPAC 312 C		1 A	5 A
- earth-fault unit of SPAC 310 C		1 A	5 A
- earth-fault unit of SPAC 312 C	0.2 A	1 A	
Thermal withstand capability			
- continuous	0.8 A	4 A	20 A
- for 1s	20 A	100 A	300 A
Dynamic current withstand,			
- half-wave value	50 A	250 A	750 A
Input impedance	<750 m Ω	<100 m Ω	<20 m Ω
Rated frequency	50 Hz		
Rated frequency on request	60 Hz		

mA inputs

Terminal numbers	
- active power	X3/1-2
- reactive power	X3/3-4
Input current range	-20...0...20 mA

Binary inputs

Terminal numbers	
- channels 1...3, four-pole inputs	X2/8-14, 9-14, 10-14, 11-14, 12-14, and 13-14
- channels 4...9, single-contact inputs	X2/1-5, 2-5, 3-5, 4-5, 6-7 and X1/10-11
Input voltage range	
- input module type SPTR 3B12	80...265 V dc
- input module type SPTR 3B13	30...80 V dc
Current drain	about 2 mA

Energy pulse counter input (input channel 7)

Terminal numbers	X2/4-5
Maximum frequency	25 Hz
Input voltage range	
- input module type SPTR 3B12	80...265V dc
- input module type SPTR 3B13	30...80 V dc
Current drain	about 2 mA

Blocking input (input channel 8)

Terminal numbers	X2/6-7
Input voltage range	
- input module type SPTR 3B12	80...265V dc
- input module type SPTR 3B13	30...80 V dc
Current drain	about 2 mA

Contact outputs

Control output numbers	X0/65-66 and 85-86
- rated voltage	250 V ac or dc
- continuous carry	5 A
- make and carry for 0.5 s	30 A
- make and carry for 3 s	15 A
- breaking capacity for dc, when the control circuit time constant $L/R \leq 40$ ms at the control voltage levels 48/110/220 V dc	5 A/3 A/1 A
- control output operating mode, when operated by the control module	pulse shaping
- control pulse length	0.1...100 s
Signalling output numbers	X1/1-2-3, 4-5, 6-7 and 8-9
- rated voltage	250 V ac or dc
- continuous carry	5 A
- make and carry for 0.5 s	10 A
- make and carry for 3 s	8 A
- breaking capacity for dc, when the control circuit time constant $L/R \leq 40$ ms at the control voltage levels 48/110/220 V dc	1 A/0.25 A/0.15 A

Auxiliary supply voltage

Type of built-in power supply module and supply voltage range	
- type SPGU 240 A1	80...265 V ac or dc
- type SPGU 48 B2	18...80 V dc
Burden of auxiliary supply under quiescent/operating conditions	~10 W / ~15 W

Combined overcurrent and earth-fault module SPCJ 4D29

Low-set overcurrent stage I>	
- current setting range	0.5...2.5 x I_n
- operation modes to be selected	
- definite time operation	
- operating time $t_{>}$	0.05...300 s
- inverse definite minimum time (IDMT) mode as per IEC 60255-3 and BS 142	Extremely inverse Very inverse Normal inverse Long time inverse
- special type inverse characteristics	RI-type inverse RXIDG-type inverse
- time multiplier k	0.05...1.0
High-set overcurrent stage I>>	
- current setting range	0.5...40 x I_n and ∞
- operating time $t_{>>}$	0.04...300 s

Note!

The high-current end of any inverse time characteristic is determined by the high-set stage which, when started, inhibits the low-set stage operation. The trip time is thus equal to the set

$t_{>>}$ for any current higher than $I_{>>}$. In order to get a trip signal, the stage $I_{>>}$ must be linked to a trip output.

Low-set earth-fault stage $I_0>$	
- current setting range	0.1...0.8 x I_n
- operation modes to be selected	
- definite time operation	
- operating time $t_0>$	0.05...300 s
- inverse definite minimum time (IDMT) mode as per IEC 60255-3 and BS 142	Extremely inverse Very inverse Normal inverse Long time inverse RI-type inverse RXIDG-type inverse
- special type inverse characteristics	
- time multiplier k_0	0.05...1.0
High-set earth-fault stage $I_0>>$	
- current setting range	0.1...10 x I_n and ∞
- operating time $t_0>>$	0.05...300 s

Control module SPTO 1D2

Control functions

- status indication for maximum three objects (e.g. circuit breakers, disconnectors, earth switches)
- configuration freely programmable
- remote or local control (open and close) for one object
- feeder-based interlocking freely programmable

Measurement functions

- phase currents, measuring range 0...2.5 x I_n
- phase current measuring accuracy better than ± 1 % of I_n
- active and reactive power measurement via mA-inputs, external measuring transducers are needed
- mA measuring input current range -20...0...20 mA
- power measuring accuracy better than ± 1 % of maximum value of measuring range
- energy measurement via pulse counter input or by calculating of measured power
- local and remote reading of measured data as scaled values

Data communication

Rear panel	
Connection	RS-485, 9-pin, female
Bus connection module for rear connection	
- for plastic-core optical fibres	SPA-ZC 21C BB
- for glass-fibre optical fibres	SPA-ZC 21C MM
Bus connection module for separate mounting	
- for plastic-core optical fibres	SPA-ZC 17C BB
- for glass-fibre optical fibres	SPA-ZC 17C MM
Front panel	
- connection	RS 232, 9-pin, female
Data code	ASCII
Selectable data transfer rates	4800 or 9600 Bd

Insulation Tests *)

Dielectric test IEC 60255-5	2 kV, 50 Hz, 1 min
Impulse voltage test IEC 60255-5	5 kV, 1.2/50 μ s, 0.5 J
Insulation resistance measurement IEC 60255-5	>100 M Ω , 500 Vdc

Electromagnetic Compatibility Tests *)

High-frequency (1 MHz) burst disturbance test IEC 60255-22-1	
- common mode	2.5 kV
- differential mode	1.0 kV
Electrostatic discharge test IEC 60255-22-2 and IEC 61000-4-2	
- contact discharge	6 kV
- air discharge	8 kV
Fast transient disturbance test IEC 60255-22-4 and IEC 61000-4-4	
- power supply	4 kV
- I/O ports	2 kV

Environmental conditions

Specified ambient service temperature	-10...+55 °C
Transport and storage temperature range	-40...+70 °C
Long term damp heat withstand according to IEC 60068- 2- 3	<95%, at 40 °C for 56 d
Degree of protection by enclosure when panel mounted	IP 54
Mass of the unit	about 5 kg

*) The tests do not apply to the serial port, which is used exclusively for the bus connection module.

Exchange and spare parts	Control module	SPTO 1D2
	Combined overcurrent and earth-fault module	SPCJ 4D29
	I/O module, input voltage range 80...265 V dc	SPTR 3B12
	I/O module, input voltage range 30...80 V dc	SPTR 3B13
	Power supply module, 80...265 V ac or dc	SPGU 240 A1
	Power supply module, 18...80 V dc	SPGU 48B2
	Housing without plug in modules, SPAC 310 C	SPTK 4F1
	Housing without plug in modules, SPAC 312 C	SPTK 4F2

Maintenance and repairs

When the protection relay is operating under the conditions specified in the section "Technical data", the relay is practically maintenance-free. The relay modules include no parts or components subject to an abnormal physical or electrical wear under normal operating conditions.

If the environmental conditions at the relay operating site differ from those specified, as to temperature and humidity, or, if the atmosphere around the relay contains chemically active gases or dust, the relay ought to be visually inspected in association with the relay secondary test being performed. At the visual inspection the following things should be noted:

- Check for signs of mechanical damage on relay case and terminals
- Dust inside the relay cover or case; remove carefully by blowing pressurized air
- Rust spots or signs of erugo on terminals, case or inside the relay

If the relay fails in operation or if the operating values exceedingly differ from those of the relay specifications, the relay should be given a proper overhaul. Minor measures can be taken by personnel from the customer's company instrument work-shop but all major measures involving overhaul of the electronics are to be taken by the manufacturer. Please contact the manufacturer or his nearest representative for further information about checking, overhaul and recalibration of the relay.

Note!

Static protective relays are measuring instruments and should be handled with care and protected against moisture and mechanical stress, especially during transport.

Order information

The following information should be given when ordering feeder terminals.

1. Quantity and type designation	15 units SPAC 310 C
2. Rated frequency	$f_n = 50$ Hz
3. Auxiliary supply voltage	$U_{aux} = 110$ V dc
4. Type designation of the configuration plate	SYKK 912
5. Accessories	15 units, connection module SPA-ZC 21C BB

Four empty legend text films SYKU 997 for channel 4...9 indication are included in the feeder terminal delivery.

As different configuration plates are available for the feeder terminals SPAC 310 C and SPAC 312 C the type designation of the configuration plate should be stated in the order.

There are two parallel configuration plates for one circuit breaker/disconnector configuration; in the first type the closed status is indicated by red colour and open status by green colour, in the second type the colours are the opposite. The following standard configuration plates are available.

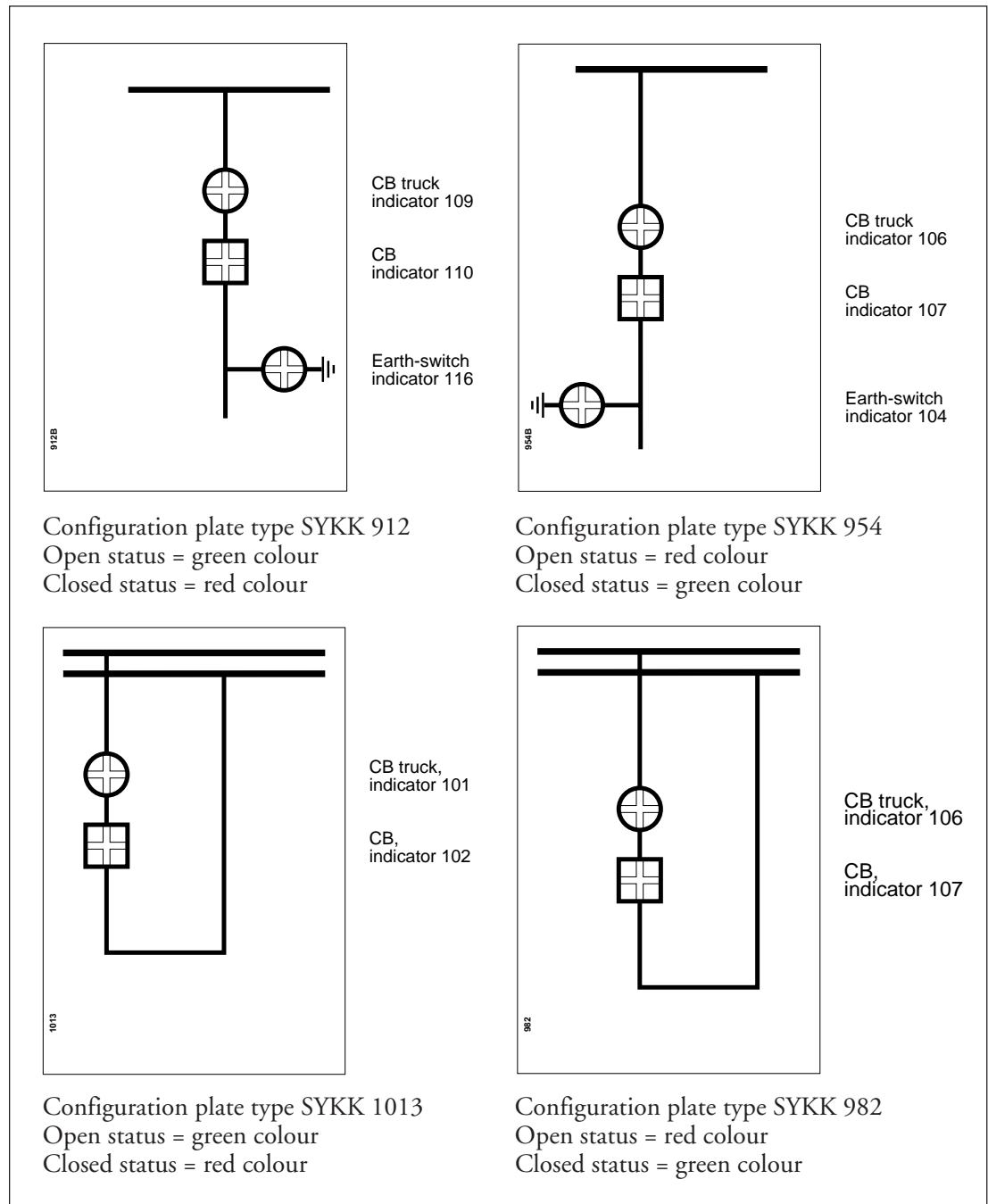

Fig. 8. Standard configuration plates for SPAC 310 C and SPAC 312 C

Note!

Regardless of the configuration plate the control module always has the default configuration and interlocking 1 when delivered.

On special request other types of configuration plates can be delivered. Figure 9 shows the LED matrix of the control module. To help design customized configuration plates the customer is requested to sketch the single line diagram of his configuration and to give his proposal for the configuration plate with the help of Fig. 9. The following instructions should be kept in mind:

- In columns 1 and 3 red LEDs are in vertical position and green LEDs in horizontal position
- In columns 2 and 4 red LEDs are in horizontal position and green LEDs in vertical position

- A circuit breaker is illustrated by a square
- A disconnector is illustrated by a circle
- When indicating closed status by red LEDs, the earth-switch should be on the right hand side, see SYKK 912
- When indicating closed status by green LEDs, the earth-switch should be on the left hand side, see SYKK 954
- When indicating closed status by red LEDs, the CB should refer to indicator No. 102 or 110
- When indicating closed status by green LEDs, the CB should refer to indicator No. 107 or 115

SPAC 31__ C CONFIGURATION	
CLIENT	
SUBSTATION	
FEEDER	
SINGLE LINE DIAGRAM	
	
NOTES	
DRAWN BY	DATE

Fig. 9. Form for sketching customized configuration plates for SPAC 310 C and SPAC 312 C. The circles of the configuration plate illustrate the LED indicators.

SPTO 1D2

Control module

User's manual and Technical description

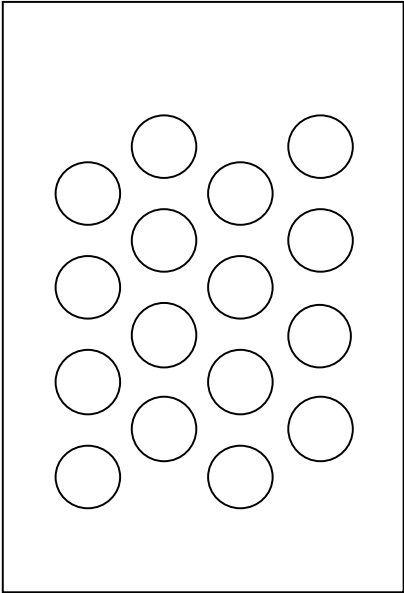
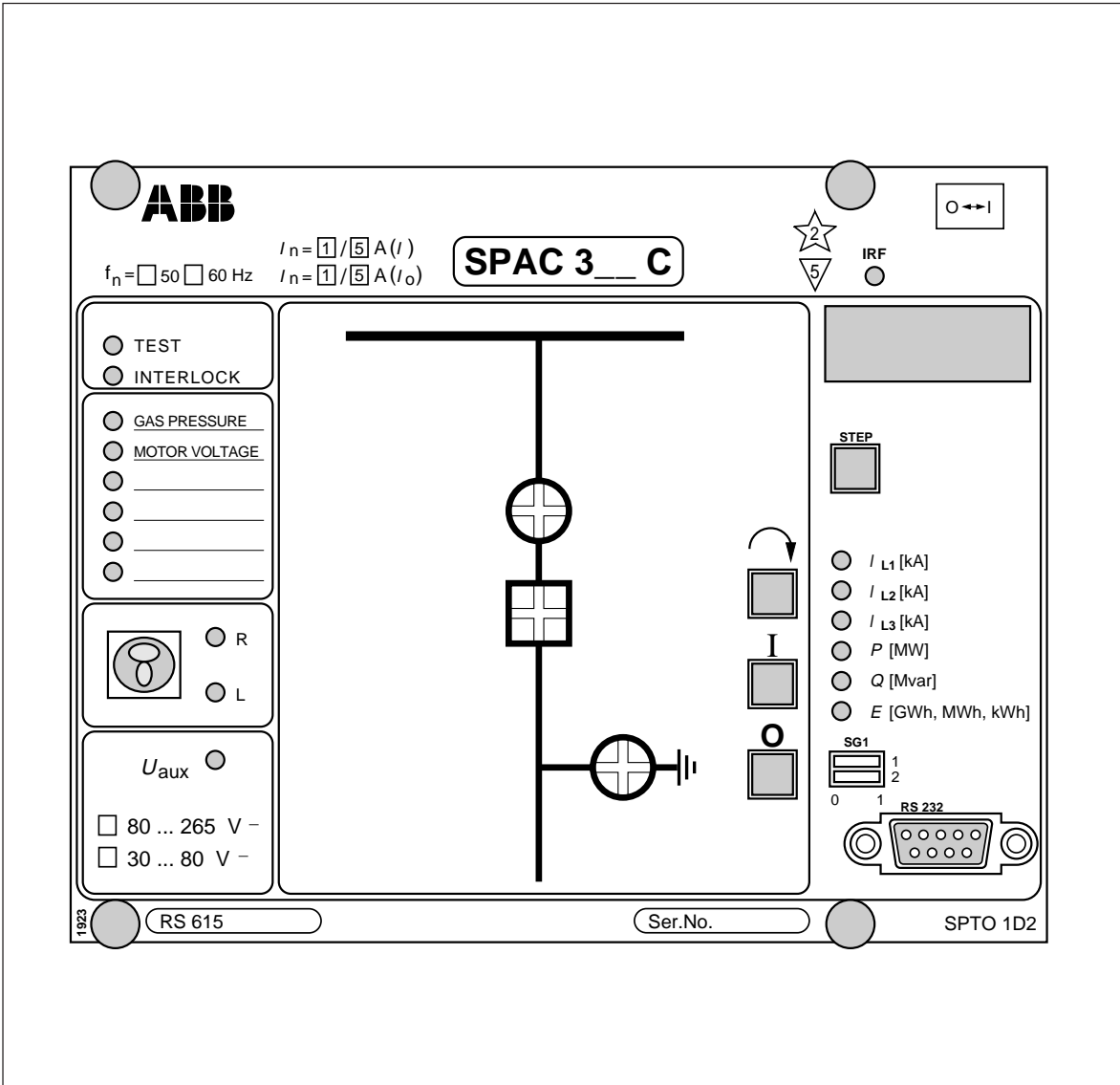

Issued 97-08-26
Version A (replaces 34 SPTO 4 EN1)
Checked
Approved

Data subject to change without notice

Contents	Description of functions	3
	Control functions	3
	Measurement functions	3
	Block diagram	4
	Front panel	5
	Object status indicators	5
	Indicators for input channels 4..9	6
	Operation indicators.....	6
	REMOTE/LOCAL key switch	6
	∩, I and O push-buttons	7
	Switchgroup SG1	7
	Display of measured values and serial communication parameters.....	7
	RS 232 interface	9
	Programming.....	10
	Configuration	10
	Interlocking	13
	Conditional Direct Output Control	16
	Input channels 4..13	17
	Outputs	18
	Scaling of measurements.....	19
	Event codes	21
	Programming quick reference	23
	Serial communication parameters	24
	Default values of the parameters	29
	Technical data	30
	Appendix 1, Default configuration and interlocking 1	31
	Appendix 2, Default configuration and interlocking 2	32
	Appendix 3, Default configuration and interlocking 10	33

Description of functions

Control functions

The control module type SPTO 1D2 reads binary input signals and indicates the status of these signals locally and remotely. The control module also performs OPEN and CLOSE commands.

The input channels 1...3 are used for reading status information of circuit breakers and disconnectors (objects). Each of these channels includes two physical inputs, one for object open and one for object closed information. The module indicates the status information locally on the front panel by means of LED indicators and transfers the information to station level equipment via the SPA bus.

The control module is able to read the status information of maximum 3 objects. The front panel has a matrix of status indication LEDs. The configuration indicated by these LEDs is freely programmable by the user.

Input channels 4...13 consist of one physical binary input. These channels are used mainly to transfer binary signals other than circuit breaker and disconnector status information over the SPA bus to the remote control system. There is a local LED indication for the input channels 4...9 on the front panel.

The control module is able to give OPEN and CLOSE commands for one object. The commands may be given by means of the local push-buttons, via the SPA bus or the input channels 4...13. The output is a pulse with programmable pulse length.

An enable signal must be given by an interlocking program before the OPEN or CLOSE output pulse can be activated. The enable signal is given on the basis of the status of input channels 1...3 and 4...13 and the programmed logic.

The signalling outputs, SIGNAL 1...3, can be used to indicate the status of input channels 4...13. The selected output is active as long as the input channel is active.

The outputs OPEN, CLOSE or SIGNAL 1...3 can be controlled by the conditional direct output control program. The program is similar to that of interlocking. The user can define when an output is to be activated. This is depending on the status of inputs 1...3 and 4...13 and the programmed logic. The output is active as long as the program gives the output signal.

Measurement functions

The control module SPTO 1D2 is able to measure three phase currents and two mA signals. The mA inputs are used for measuring active and reactive power. External measuring transducers are needed.

Input channel 7 can be used as a pulse counter for energy pulses. Energy can also be calculated on the basis of the measured power.

The measured signals can be scaled and they are indicated locally and over the SPA bus as actual values.

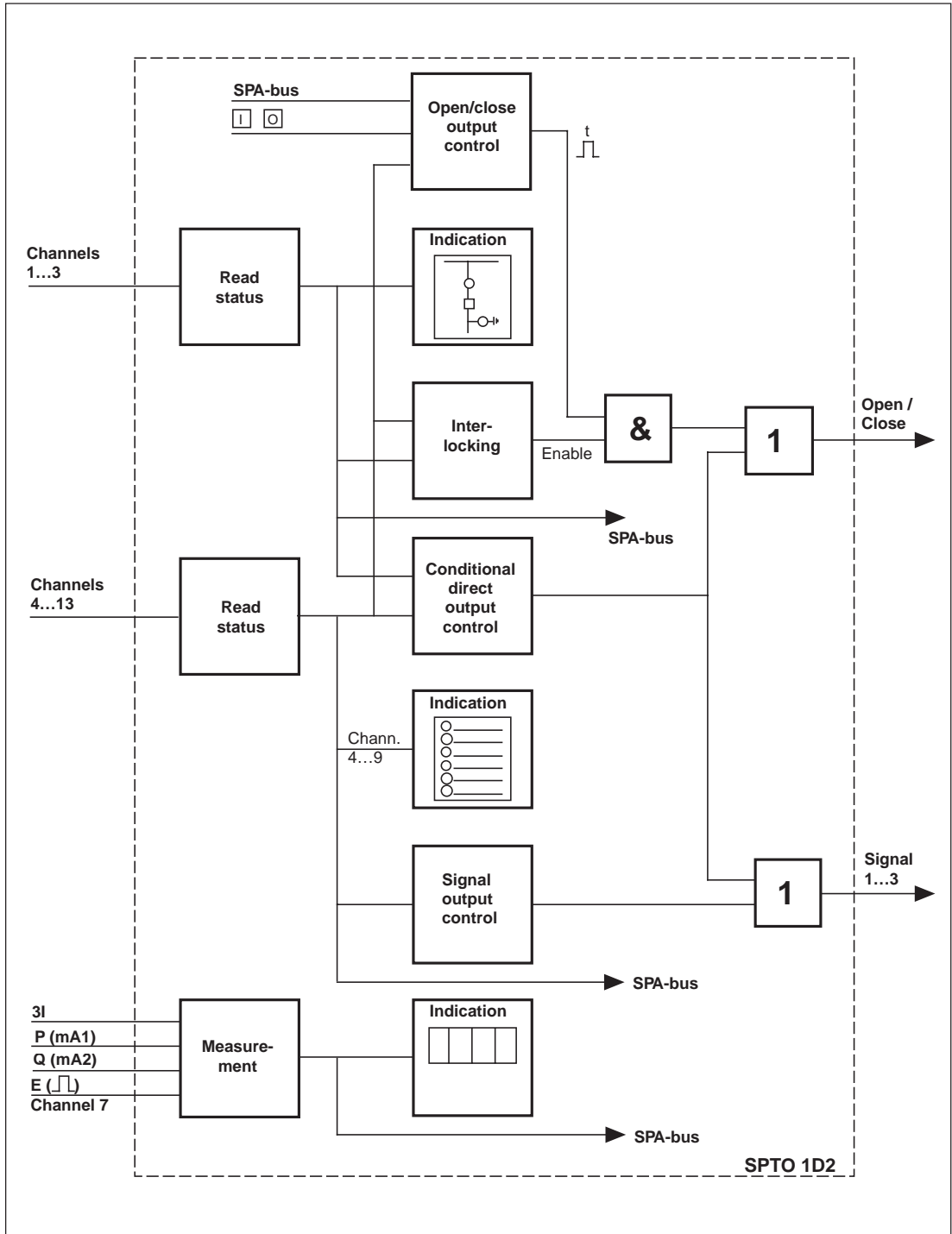

Fig. 1. Block diagram of the control module SPTO 1D2.

Front panel

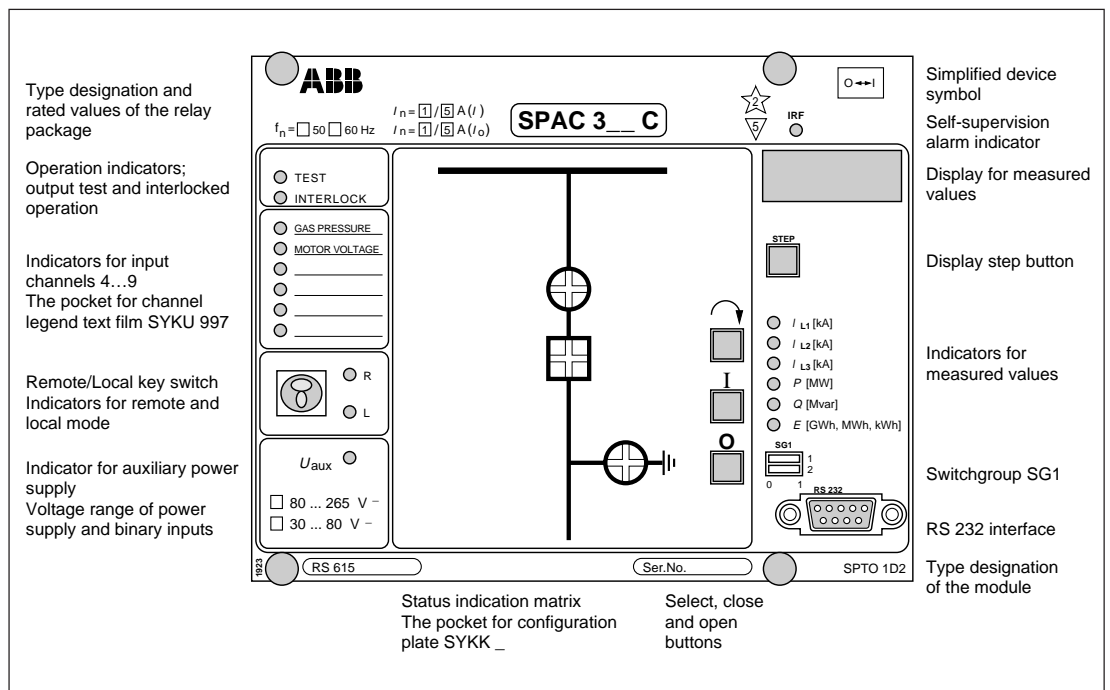

Fig. 2. Front panel of the control module SPTO 1D2 without the configuration plate SYKK__ and the channel legend text foil SYKU 997.

Object status indicators

The front panel has 16 LED indicators for local status indication. The indicators are arranged as a 4 x 4 matrix. Three of these indicators can be used simultaneously in the control module SPTO 1D2. The combination of indicators used is freely programmable by the user, see chapter "Configuration".

In front of the indicators there is a pocket for a separate plastic configuration plate type SYKK_. The bottom of the pocket is open. By changing the configuration plate and programming a new indicator combination different kinds of bays can be described.

The circuit breakers and disconnectors of the bay are shown on the configuration plate. The configuration plate has a transparent window in front of the indicators that are in use. The unused indicators are hidden.

One object indicator is composed of four LEDs, two vertical and two horizontal. Two of the LEDs are red and two are green. The red LEDs are vertical and the green LEDs horizontal in columns 1 and 3, see Fig. 6. In the columns 2 and 4 the green LEDs are vertical and the red LEDs horizontal. Due to this system both colours can be used to indicate either open or closed status.

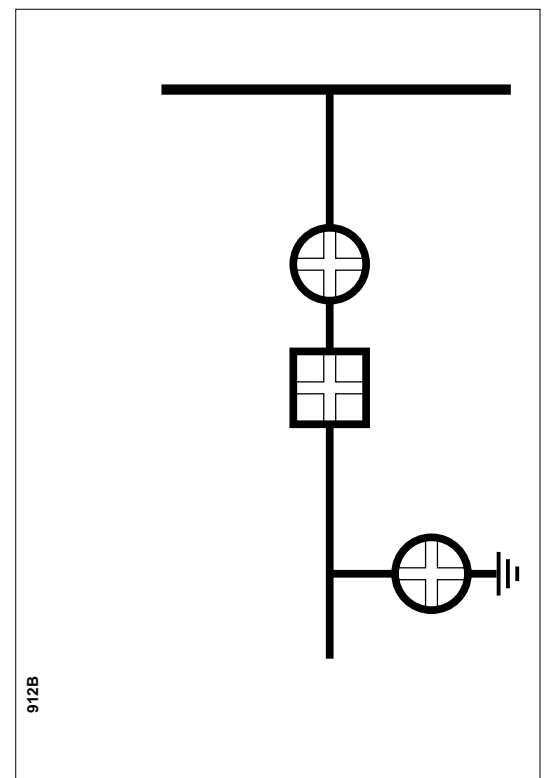

Fig. 3. Example of plastic configuration plate SYKK_. The size of the plate is 72 x 106.5 mm.

Indicators for input channels 4...9

The status of the input channels 4...9 is indicated locally on the front panel. Channel 4 refers to the upmost red indicator and channel 9 to the lowest one.

An input can be defined to be active at high state (NO contact) or active at low state (NC contact). The LED is lit when the input is active.

The indication of the active status of the input channels 4...9 can separately be programmed to be memory controlled. If an input channel

indicator is memory controlled the LED indicator remains lit until the channel is locally reset by pressing the push-buttons STEP and SELECT simultaneously or by remote control via the serial interface using the parameter S5, which is given the value 0 or 1.

The front panel has a pocket for a text legend foil, SYKU 997, on which the user can write the desired input legend text. The left side of the pocket is open. An empty text legend foil is delivered with the relay package.

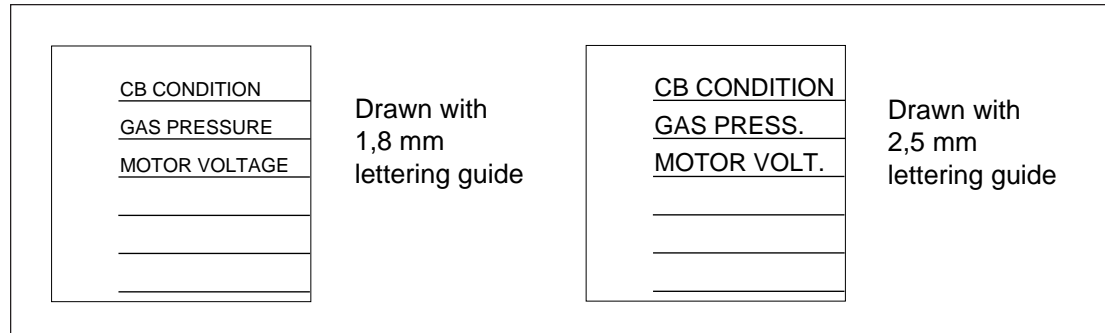

Fig. 4. Example of text legend foil SYKU 997. The foil is shown in actual size, width 33.5 mm and height 34 mm.

Operation indicators

The control module includes two red operation indicators showing the status of the module

itself. These LEDs are normally dark. The indicators have the following function:

Indicator	Function
TEST	Is lit when the switch SG1/1=1. Then the interlockings are out of use
INTERLOCK	Is lit when a local control command is given and the operation of an object is inhibited by the interlocking program. This LED can be switched off by pressing the SELECT push-button or it is automatically switched off after a timeout of about 30 seconds When the control module is in the programming mode and the interlockings are in use the indicator lights and it is switched off when the operation mode is entered or when the interlockings are set out of use.

The green indicator U_{aux} indicates that an external power supply voltage is connected and the power supply module of the unit is operating.

The input voltage range of the digital inputs and the power supply module is marked below the U_{aux} indicator.

REMOTE/LOCAL key switch

To be able to use the local OPEN and CLOSE push-buttons, the key switch must be in the position LOCAL, indicated by the yellow LED L. All remote controls via the serial communication are inhibited, but control operations via input channels 4...13 or control operations by the conditional direct output control function are allowed.

Accordingly, to be able to control an object via the serial communication, the key switch must be in the REMOTE position indicated by the yellow LED R. When the key switch is in the REMOTE position, local push-button controls are inhibited.

The key can be removed both in local and in remote position.

∩, I and O push-buttons

The local control sequence is started by pressing the push-button ∩ (SELECT). After that the LED indicator of the object which has been defined controllable starts flashing.

The closing or opening command is given by using the I (close) or O (open) push-button. Depending on the status of inputs 1...3 and 4...13 and the interlocking program logic the control module executes the selected command or turns on the INTERLOCK-LED indicating that the operation is interlocked.

If the object is closed the indicator for closed position starts flashing and if the object is open the indicator for open position starts flashing. The indicator remains flashing until a control command is given or a timeout of 10 s has elapsed.

The length of the the control output pulse can be programmed within the range 0.1...100 s.

Switchgroup SG1

Switch	Function
SG1/1	Switch SG1/1 is used to inhibit interlocking during testing When SG1/1=0, the interlockings are in use When SG1/1=1, the interlockings are not in use and the red TEST- LED is lit. All control operations are allowed. NOTE! This switch position should be used for testing purposes only!
SG1/2	Switch SG1/2 is not in use and should be in position 0.

Display of measured values and serial communication parameters

The displayed items can be stepped through by pressing the STEP push-button. The measured values are indicated by the three green digits at

the extreme right. A yellow LED indicator below the STEP push-button shows, when lit, which measured value is indicated on the display.

Indicator	Data to be displayed
I _{L1} [kA]	The measured phase current I _{L1} in actual kiloamperes. The range is 0.000...999 kA, 0.000 is indicated as .000
I _{L2} [kA]	The measured phase current I _{L2} in actual kiloamperes. The range is 0.000...999 kA, 0.000 is indicated as .000
I _{L3} [kA]	The measured phase current I _{L3} in actual kiloamperes. The range is 0.000...999 kA, 0.000 is indicated as .000
P [MW]	The measured active power in megawatts. Both positive and negative values are indicated. The positive values have no sign but the negative sign is indicated by the red digit
Q [MVar]	The measured reactive power in megavars. Both positive and negative values are indicated. The positive values have no sign but the negative sign is indicated by the red digit
E [GWh,MWh,kWh]	The measured active energy. The energy is displayed in three parts; in gigawatthours, in megawatthours and in kilowatthours

Also the serial communication parameters are indicated by the four-digit display. The address of the data to be displayed is indicated by the red digit at the extreme left of the display.

Red digit	Data to be displayed
A	Serial communication address. May have a value within the range 0...254. The default value is 99.
b	Serial communication baudrate. May have values 4.8 or 9.6 kBd. The default value is 9.6 kBd.
C	Serial communication monitor. If the device is connected to a data communicator and the communication system is operating the monitor reading is 0, otherwise the numbers 0...255 are rolling in the display

Continuous display of one measured value or automatic display switch-off after a 5 minutes timeout can be selected.

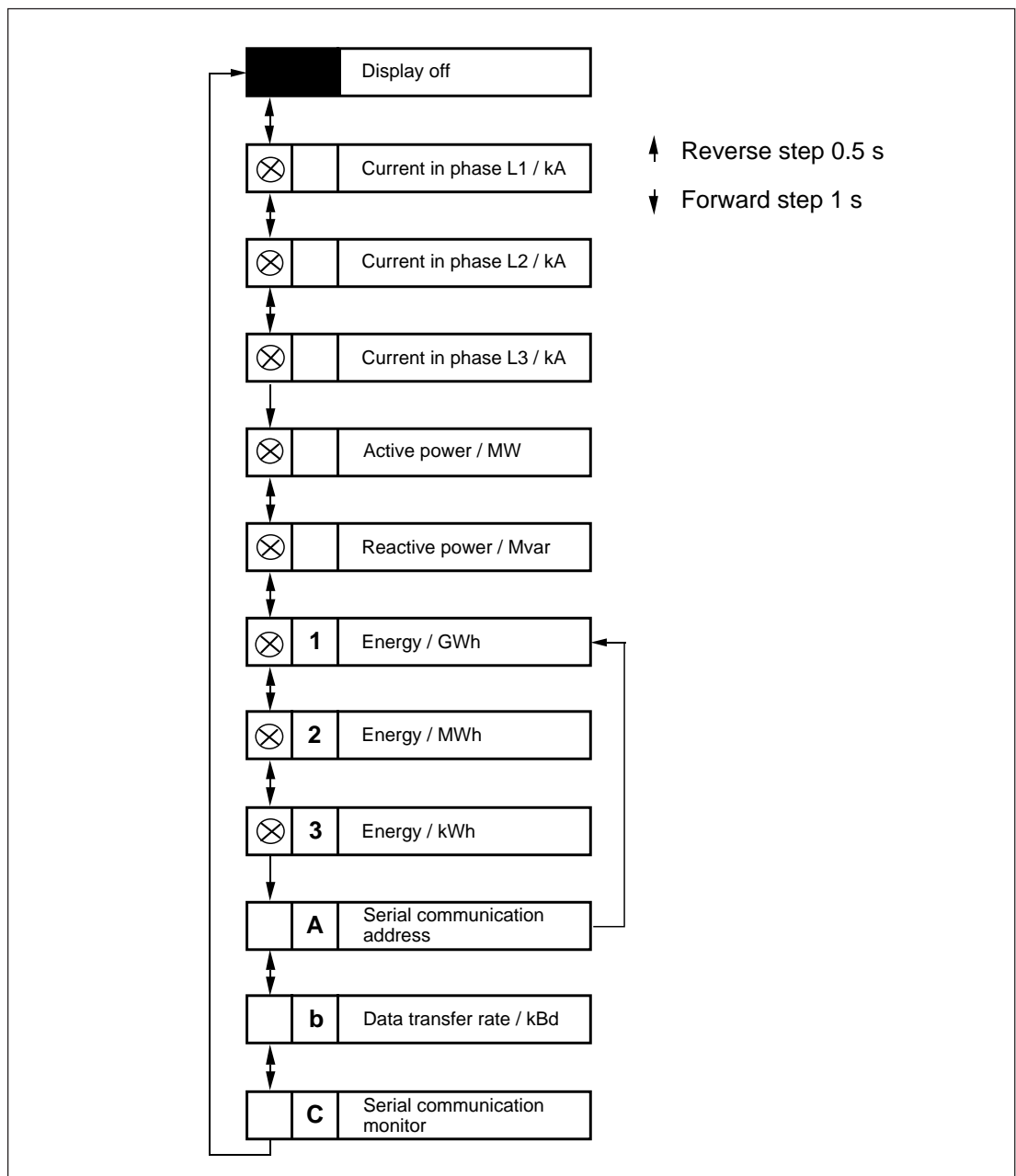

Fig. 5. Display menu of the control module SPTO 1D2.

RS 232 interface

The 9-pin RS 232 interface on the front panel is to be used for programming the control module from a terminal or a PC. The control module SPTO 1D2 supervises the serial communication of the feeder terminal. This enables protection modules of the same terminal to be set via the RS 232 interface.

If a terminal or a PC is connected to the RS 232 interface the SPA-bus interface on the rear panel of the feeder terminal is disconnected. When using the RS 232 interface, the SPA-bus protocol has to be used.

The following serial communication parameters should be used:

- Number of data bits, 7
- Number of stop bits, 1
- Parity, even
- Baudrate, 9.6 kilobauds as a default

The next table shows the signal names and pin numbers of the cable to be used between the RS 232 interface and a programming device.

RS 232 interface of SPTO 1D2		Programming device		
Signal name	Pin number 9-pin male conn.	Pin number 9-pin female conn.	Pin number 25-pin male conn.	Signal name
Data receive	2	3	2	Data transmit
Data transmit	3	2	3	Data receive
Ground	5	5	7	Ground
DSR	6	4	20	DTR

Programming

Configuration

The control module SPTO 1D2 is able to indicate the status of maximum 3 objects (circuit breakers or disconnectors) and to control (open or close) one object.

The control module can be used for different circuit breaker / disconnector / earth-switch configurations within the above mentioned limits. The configuration can be defined freely by using configuration commands explained below or by choosing a suitable default configuration. Each default configuration uses a fixed interlocking scheme.

The default configurations and interlockings are explained in the appendixes 1...3. If the configuration or the interlocking is not suitable for a certain application then both must be programmed by the user.

After factory testing the default configuration and interlocking 1 has been selected for the control module. Another default configuration is chosen by writing the configuration number for variable S100 via the SPA bus.

Normally the control module is in the run mode which means that the interlocking program is executed. When programming a configuration or selecting a new default setting the control module must be in the program mode (S198=0).

Example 1: Selection of the default configuration and interlocking 2 instead of default 1.

```
>99WS198:0:XX
; Change into program mode
>99WS100:2:XX
; Select the default 2
>99WS198:1:XX
; Change into run mode
>99WV151:1:XX
; Store the programmed parameters
```

If variable S100 is 0, the configuration is freely programmable. In this case all indicators are initially set out of use. In a freely programmable configuration, only the objects to be used must be programmed.

The three input channels 1...3 can be used to read status data of circuit breakers and disconnectors. The input channel numbers are used when programming the feeder terminal configuration.

The front panel indicators are numbered from 101 to 116. These numbers are used when programming the feeder terminal configuration. The positions and the numbers of the indicators in the matrix are shown in Fig. 6.

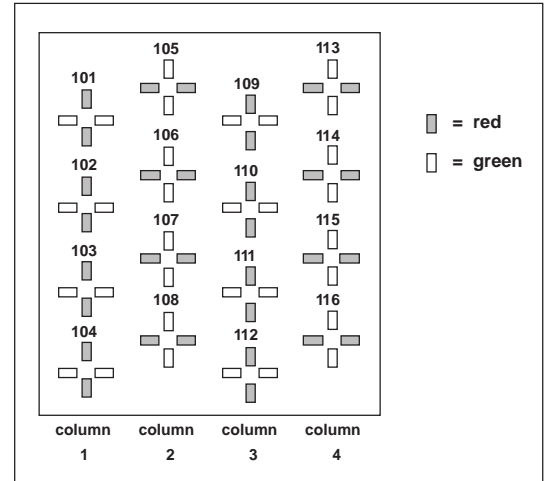

Fig. 6. Position, number and colour of the indicators on the front panel of SPTO 1D2.

The control module has two outputs, OPEN and CLOSE, for controlling one object. The control outputs have their own codes, 20 and 21, which have to be used when programming a configuration. The corresponding operation is given in the following table.

Output code	Operation
20	OPEN
21	CLOSE

For the correspondence between the input and output codes and the rear panel terminal numbers see chapter "Connection diagram" in the user's manual of the feeder terminal.

When programming a configuration an indicator number, a four-pole input number and an output code are linked together using one SPA protocol command.

The setting parameters S101...S116 which refer to the indicator numbers 101...116 are reserved for the configuration commands. As an output number either the code of OPEN output or CLOSE output can be used. Also some other parameter, such as type of object and position of open and closed status indicators, are defined in the SPA protocol command.

Example 2: Indicator 109 (S109) indicates the status read via input channel 2. Output 20 is used for opening the object which means that output 21 must be used for closing the same object. The object is a circuit breaker and the closed status is indicated by vertical red LEDs.

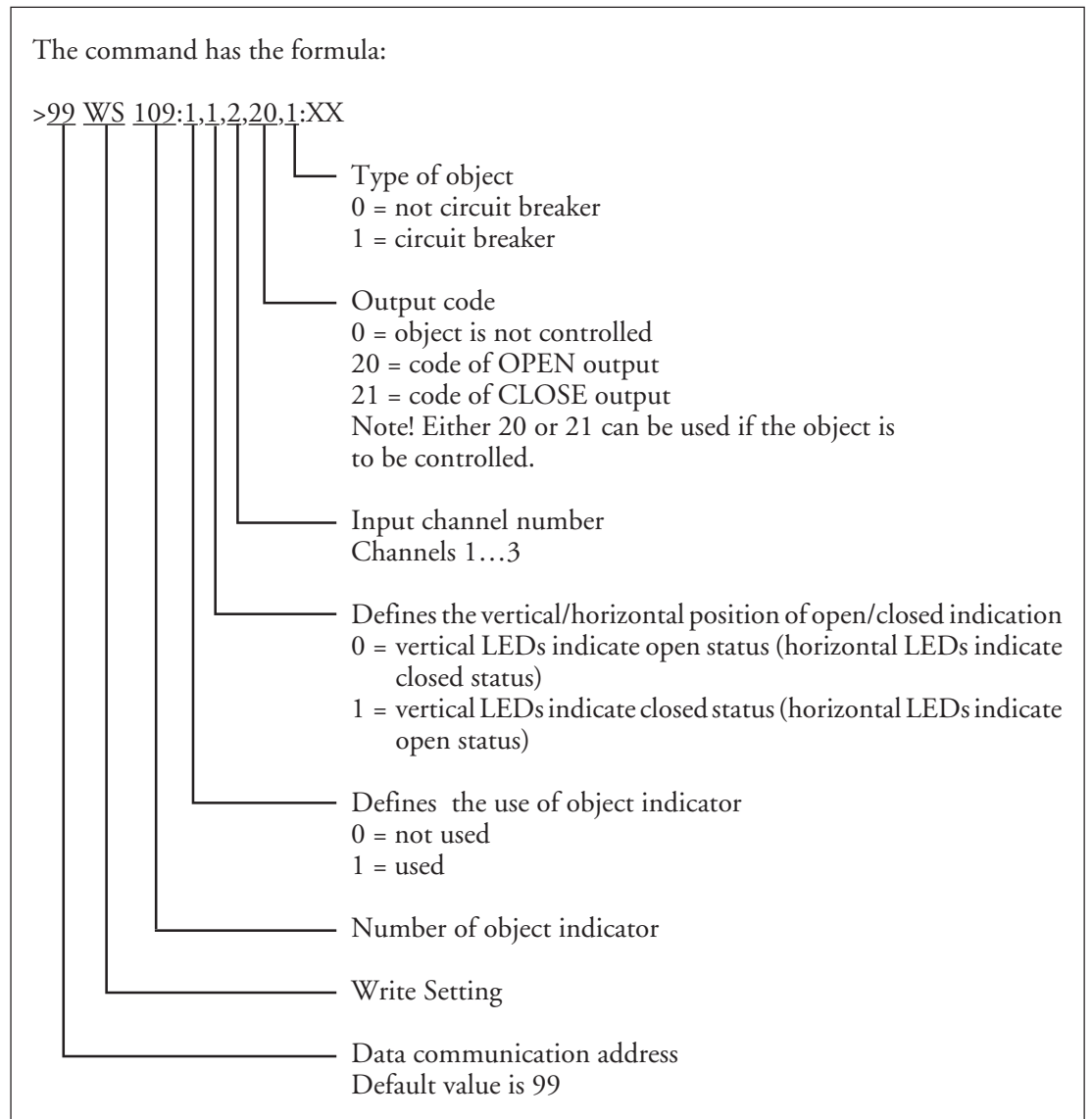

Syntax rules for programming the configuration for SPTO 1D2:

1. The programming has to be done in the program mode.
2. Maximum three objects can be configured (three settings in the range of S101...S116).
3. Only input channel numbers 1...3 are accepted. Each number can be used only once.
4. If an object indicator is not used, no other values need to be given.
5. Output code 20 or 21 can be given only once. If the output code is 0, the definition of the object (CB/other object) need not be given.
6. Only one object can be defined to be a circuit breaker.

Example 3: To program a configuration similar to the default configuration 1 (indicator 109 CB truck, indicator 110 CB and indicator 116 earth-switch), the following commands are required:

```

>99WS198:0:XX
; Change into program mode
>99WS100:0:XX
; Change into freely programmable mode
>99WS109:1,1,1,0:XX
; CB truck : vertical red LEDs indicate
closed status, input channel 1, not
controlled
>99WS110:1,1,2,20,1:XX
; Circuit breaker : vertical red LEDs
indi cate closed status, input channel 2,
controlled
>99WS116:1,1,3,0:XX
; Earth-switch : horizontal red LEDs
indicate closed status, input channel 3,
not controlled
>99WV151:1:XX
; Store the programmed parameters

```

The programmed configuration can be read indicator by indicator or with a single command.

Example 4: To read the configuration of indicators 101...116 with one command only.

```
>99RS101/116:XX
```

This command will give all the setting values of every indicator (101 to 116), including those not configured into the system. The parameters of indicators not in use are zero.

After this also the interlocking program must be written before opening or closing of the circuit breaker is possible. See Chapter "Interlocking".

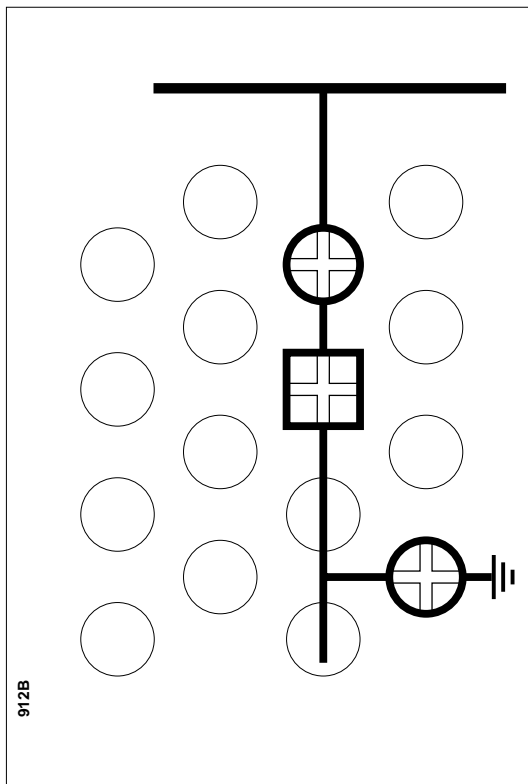

Fig. 7. Configuration programmed in the example number 3.

An interlocking program is used to inhibit the closing or opening command for a controllable object in certain situations. In practice, in the control module SPTO 1D2, the interlocking enables the control operations, i.e. everything that is not enabled by the interlocking program is inhibited.

The default configurations have their own default interlocking programs, see appendixes 1...3. If a default interlocking related to a default configuration is not suitable, both configuration and interlocking must be programmed by the user.

The interlocking system of the control module reads the status of input channels 1...3 and 4...13. The interlocking program enables the opening or closing of a controllable object but a separate open or close command must be given via the local push-buttons, the serial bus or the input channels 4...13.

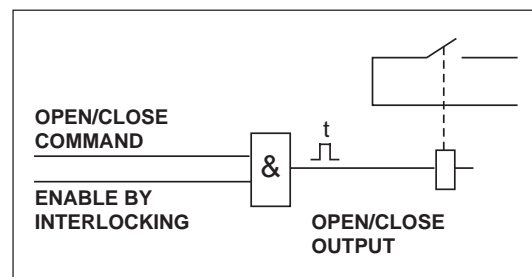

Fig. 8. Operation principle of OPEN and CLOSE outputs.

When the parameter S198 = 0, the module is in the program mode, and when the parameter S198 = 1, the module is in the run mode. In the run mode the interlocking program is executed and it cannot be changed by the operator. The operations enabled by the interlocking program can be carried out.

In the program mode the interlocking program is not executed and program changes can be done. In this mode the control of the objects is not allowed, except in the case that interlockings are completely out of use. The interlocking is programmed or a default interlocking is selected in the program mode.

The interlocking logic, when used, is always operative both in local and remote control mode and if the control commands are given via input channels 4...13. The interlocking program is executed every 20 ms. With setting S199 the interlocking can be taken completely out of use.

Example 5: In example 3 a configuration was programmed. If the interlockings are not used the programming continues with the following commands:

```
>99WS199:0:XX
; Disable interlockings
>99WV151:1:XX
; Store the programmed parameters
```

In this case when the interlockings are not programmed, the value 1 cannot be given for the parameter S198. However, the status indication and object control operate as normal because the interlockings are disabled.

The interlockings are programmed via the SPA bus using the language according to the DIN 19239 standard. The structure of a program command is:



OPERATION is a logic command
OPERAND is a code of an input or an output or a number of a temporary or a special register

The following logic commands are used:

LOAD	Reads the status of an input or a register
LOADN	Reads the inverted status of an input or a register
AND	And operation
ANDN	And not operation
OR	Or operation
ORN	Or not operation
OUT	Writes to an output or a register
END	End of the program

For inputs 1...3 a separate operand code is defined for each status, open, closed or undefined. The activated status of inputs 4...13 can be used as an operand in the logic.

In SPTO 1D2 the following operand values can be used with operations LOAD, LOADN, AND, ANDN, OR, ORN :

- 1...3 = input channel number
; Code of an input, if the status "closed" should be used
- 101...103 = input channel number + 100
; Code of an input, if the status "undefined" should be used
- 201...203 = input channel number + 200
; Code of an input, if the status "open" should be used
- 4...13 = input channel number
; Code of an input, if the status "active" should be used
- 70...89 ; Number of a temporary register
- 60 and 61 ; Number of a special register
- 62 ; Position information of the L/R key switch

In SPTO 1D2 the following operand values can be used with operation OUT:

- 20 or 21 ; Code of an output
- 70...89 ; Number of a temporary register

The input channel numbers and the output codes are those defined when programming the configuration.

The two special registers, 60 and 61, have constant values; register 60 is always zero (0) and register 61 one (1). Register 62 is used for position information of the L/R key switch; register 62 is one (1) when the L/R key switch is in REMOTE position and zero (0) when the key switch is in LOCAL position. The registers 70...89 are used as temporary data storage during the interlocking program execution.

Example 6: How to store the result of a logic operation into a temporary register.

```
>99WM200:LOAD 201:XX
; Read the open status of an object wired
to the input 1
>99WM201:AND 202:XX
; Read the open status of an object wired
to the input 2
>99WM202:OUT 70:XX
; Write the result of the logic operation
into register 70
```

After these commands register 70 is 1, if both objects are open.

Example 7: How to use input channels 4...13 in the logic.

```
>99WM200:LOAD 1:XX
; Read the closed status of an object wired
to input 1
>99WM201:AND 4:XX
; Read the active status of input channel 4
>99WM202:OUT 20:XX
; Enable output 20
```

After these commands the OPEN output (code 20) is enabled if object 1 is closed and input channel 4 is activated.

Syntax rules for programming the interlocking for SPTO 1D2:

1. The interlockings have to be programmed in the program mode.
2. With the interlocking program the operator defines when the opening and closing of an object is allowed.
3. The setting parameters M200...M300 are used. A setting parameter is equal to the row number of the interlocking program.
4. The program always begins at M200 and must not include empty lines.
5. The program always begins with the command LOAD or LOADN.
6. The last command of the program must be END.
7. One operand can be used only once with the OUT command.
8. Before the LOAD and LOADN commands, except for the first command, the OUT command should be used.
9. Before the END command an OUT command should be used.

Example 8: Programming of an interlocking logic. This example is related to example 3, the circuit breaker is to be controlled.

The following rules are given for the interlocking:

- Opening of the circuit breaker is always allowed.
- Closing of the circuit breaker is allowed when the CB truck is in the isolating position or in the service position and the earth-switch is open.

Instead of these written interlocking conditions, a logic diagram can be used:

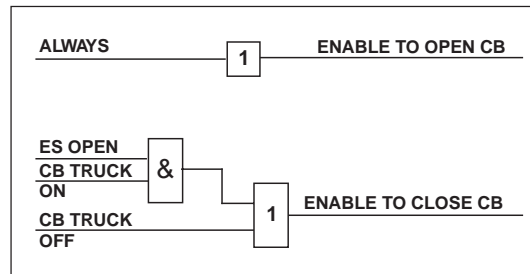

Fig. 9. Simple logic diagram for the interlocking logic for example 8

Below a detailed logic diagram is drawn.

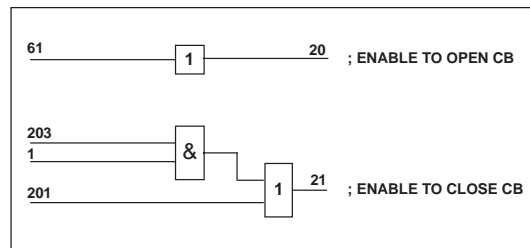

Fig. 10. Detailed logic diagram of the interlocking logic for example 8

The actual commands are written on the basis of the detailed logic diagram. As a default the program area M200...M301 is filled with END commands. The interlocking commands given by the operator are written over these END commands.

A configuration was programmed in example 3. If the interlockings described above are taken into use the programming continues with the following commands.

```
>99WM200:LOAD 61:XX
; Read the value of special register 61
; (the value is always 1)
>99WM201:OUT 20:XX
; Always enable the open command of
; the CB
>99WM202:LOAD 1:XX
; Read the closed status of the CB truck
>99WM203:AND 203:XX
; Read the open status of the earth-switch
>99WM204:OR 201:XX
; Read the open status of the CB truck
>99WM205:OUT 21:XX
; Enable the close command of the CB
>99WM206:END:XX
; End of interlocking program

>99WS198:1:XX
; Change interlocking program into run
; mode
>99WS199:1:XX
; Enable interlockings
>99WV151:1:XX
; Store the programmed parameters
```

The program is automatically compiled, when changing back into the run mode. If there are syntax errors in the program, the compiling will not be passed and the interlocking stays in the program mode. First the syntax errors must be corrected and then the interlocking system can be changed into the run mode.

The interlocking program can be by-passed in two ways;

- For testing purposes the switch SG1/1 on the front panel can be turned on. Then the interlocking program is interrupted and opening/closing of an object is always enabled.
- If the interlocking logic is to be taken out of use permanently, then variable S199 can be set to 0. Then the opening or closing of an object is always enabled.

The interlocking system does not affect the tripping signal of the protection.

Conditional Direct Output Control

The Conditional Direct Output Control logic controls the outputs OPEN, CLOSE and SIGNAL1...3. Outputs not used for controlling an object or for signalling the activation of inputs 4...13 can be controlled by the Conditional Direct Output Control function.

The outputs are activated on the basis of the programmed logic and the status of input channels 1...3 and 4...13. The controlled output remains active as long as the statuses of the inputs which caused the operation do not change.

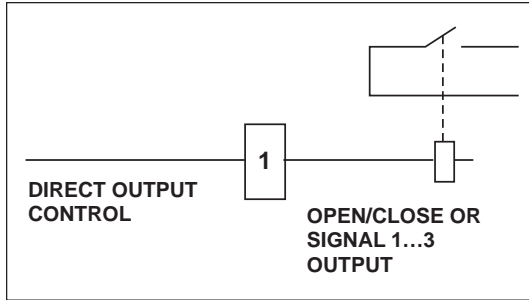

Fig. 11. Operation principle of Conditional Direct Output Control.

The programming principles and the program structure of the Conditional Direct Output Control are the same as those of the interlocking logic. The differences between these two logic programs are;

- The codes of OPEN and CLOSE outputs
- The outputs SIGNAL1...3 can be controlled by the Conditional Direct Output Control program.

The output codes are:

Output code	Definition
220	OPEN
221	CLOSE
22	SIGNAL 1
23	SIGNAL 2
24	SIGNAL 3

The Direct Output Control program is written after the interlocking program by using the SPA protocol commands M200...M300. These two programs have a common END command.

Example 9: An interlocking logic was programmed in example 8. In this example a Conditional Direct Output Control logic is added for SIGNAL 3 output.

The SIGNAL 3 output will be activated when:

- The CB truck is in the isolated position and input channel 4 is activated

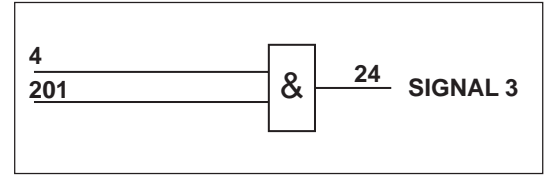

Fig. 12. Detailed logic diagram of the Conditional Direct Output Control logic for the example number 9.

The described Conditional Direct Output Control logic is effectuated with the following commands.

```

...
; Interlocking logic command lines
M200...M205
>99WM206:LOAD 201:XX
; Read the open status of the CB truck
>99WM207:AND 4:XX
; Read the active status of input 4
>99WM208:OUT 24:XX
; Activate the SIGNAL3 output
>99WM209:END:XX
; End of program

>99WS198:1:XX
; Change the program into run mode
>99WS199:1:XX
; Effectuate the program
>99WV151:1:XX
; Store the programmed parameters

```

Input channels 4...13

The input channels 4...13 are used to read binary signals other than circuit breaker and disconnect status information. The binary signals can be external contact signals or internal binary signals, e.g. starting and tripping signals of protective relay modules. For the definition of internal and external signals see chapter "Intermodular control signal exchange" in the user's manual of the feeder terminal.

The status of the binary inputs 4...13 can be read via the serial bus. The status of the input channels 4...9 is also indicated locally by LEDs on the front panel. A LED is lit when the corresponding input becomes active and the LED is switched off when the corresponding input becomes inactive.

Each input channel can be defined to be active at high state or at low state by using parameter S2. The high state activity means that an input is considered to be active if there is a voltage connected to the corresponding external input or if a protective relay module has activated its output signal. Low state activity is the opposite to high state activity. As a default all the inputs are active at high state.

The following features are related to input channels 4...13:

- Events are formed by status changes
- The channels can be used to activate the OPEN or CLOSE output pulse
- The channels can be used to inhibit the OPEN or CLOSE output pulse
- The channels can be used to activate one of the outputs SIGNAL1...3
- The channels may be included in the interlocking program logic
- The channels may be included in the Conditional Direct Output Control logic
- Channel 7 can be used as an energy pulse counter, see chapter "Scaling of measurements".

When using an input channel one signal output (SIGNAL1...3) and one control output (OPEN or CLOSE) can be activated simultaneously. Accordingly one signal output can be activated and one control output inhibited simultaneously. The output to be activated or inhibited is defined by parameters S3 and S4.

The position of the R/L keyswitch is without significance when the control outputs (OPEN or CLOSE) are controlled via inputs 4...13, but a check with the blocking logics is always made before a control action.

If an input channel is defined to control a signal output, the output is activated as long as the input is active. The length of the opening and closing pulse is defined by the SPA bus variables V5 and V6 respectively and they are not depending on the input pulse length.

Example 10: Programming of input 8. The programming can be done in the run mode.

```
>99W8S2:1:XX
; Define input 8 to be active at high state
>99W8S3:22:XX
; Configure input 8 to activate the SIGNAL1 output
>99W8S4:20:XX
; Configure input 8 to activate the OPEN output pulse
>99WV151:1:XX
; Store the programmed parameters
```

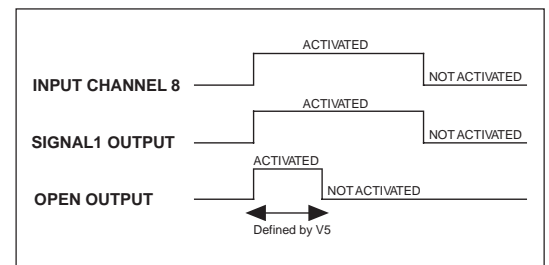

Fig. 13. Operation of outputs SIGNAL1 and OPEN when input channel 8 in example 10 is activated.

If an input channel is used for inhibiting a control command the opening or closing of an object is inhibited as long as the input is active. If the interlockings are out of use (S199=0), the input channels 4...13 cannot be used to inhibit the OPEN and CLOSE outputs.

If the input 7 is operating as an energy pulse counter, it cannot be used for other purposes. As a default the input channels 4...13 are operating in a general input mode, but are not activating or inhibiting any outputs.

The control module SPTO 1D2 has five outputs: three signal outputs (SIGNAL1...3) and two control outputs (OPEN and CLOSE). For programming the outputs are coded in the following way:

Output	Output code	Remarks
OPEN	20	For configuration and interlocking
OPEN	220	For Conditional Direct Output Control
CLOSE	21	For configuration and interlocking
CLOSE	221	For Conditional Direct Output Control
SIGNAL1	22	
SIGNAL2	23	
SIGNAL3	24	

The OPEN and CLOSE outputs can be controlled in four ways:

- Locally by using the OPEN and CLOSE push-buttons
- Remotely by commands over the serial bus
- Remotely via the binary inputs 4...13, see chapter "Input channels 4...13"
- By the Conditional Direct Output Control logic, see chapter "Conditional Direct Output Control"

To define the object to be controlled via the outputs OPEN and CLOSE, see chapter "Configuration".

When using the three first ways of operation the OPEN and CLOSE outputs give pulses. Before the output is activated the interlocking logic must enable the operation.

The pulse lengths for opening and closing outputs are defined with the SPA bus variables V5 and V6. The definitions have to be made only for the channel on which the object to be controlled is located. As a default the object to be controlled is located on channel 2.

The pulse length can be set in the range 0.1...100 s with a time resolution of 0.1 s. As a default the values for V5 and V6 of channel 2 are 0.1 s.

Example 11: The pulse lengths can be programmed in the run mode. In default configuration 1 the object to be controlled is defined to be a CB in channel 2. To change the open and close pulse lengths from 0.1 s the following SPA bus commands are used:

```
>99W2V5:0.5:XX
; Set the open pulse length to 0.5 seconds
>99W2V6:0.2:XX
; Set the close pulse length to 0.2 seconds
>99WV151:1:XX
; Store the programmed parameters
```

The open and close commands are given via the serial communication to the channel on which the object is located. The OPEN and CLOSE outputs can be controlled via the serial communication by using two different procedures:

- Direct control: An output command is given by using the parameter O1. When the parameter has been given the value 0 (open) or 1 (close) the corresponding output pulse is delivered, if enabled by the interlocking.
- Secured control: First an output is set into a state of alert by using parameter V1 for opening and parameter V2 for closing. After that the corresponding output command is executed by using parameter V3. The output pulse is given if the interlocking enables it. The state of alert is cancelled after the execute command. The state of alert can also be cancelled by using parameter V4.

When the Conditional Direct Output Control logic is used for controlling the OPEN and CLOSE output, the output is activated as long as the statuses of the inputs which have caused the operation remain unchanged.

The operation of outputs OPEN and CLOSE can be inhibited in two ways:

- By the interlocking program logic, see chapter "Interlocking"
- By input channels 4...13, see chapter "Input channels 4...13"

The outputs SIGNAL1...3 can be controlled in two ways:

- By input channels 4...13, see chapter "Input channels 4...13"
- By the Conditional Direct Output Control logic, see chapter "Conditional Direct Output Control"

The control module SPTO 1D2 includes a self-supervision system which has its own output, IRF. The output is active when auxiliary power is connected and the self-supervision system has not detected any fault. The output signal goes low if the auxiliary power supply is switched off or a permanent fault is detected. The self-supervision output is connected to the common IRF output of the feeder terminal.

Scaling of measurements

The control module is able to measure three phase currents, active and reactive power and energy. The phase currents are measured via the 1 A or 5 A current inputs of the feeder terminal. For measuring active and reactive power the module includes two mA-inputs. The output signals of external measuring transducers are wired to these two inputs. Energy can be measured in two ways; by using input 7 as a pulse counter or integrating the measured power. If the pulse counter is used an external energy meter with a pulse output is needed.

Phase currents

The three phase currents are displayed locally and transferred in actual kiloamperes via the serial bus. To be able to do this the current measurement must be scaled. The scaling is based on the entered rated current of the primary side of the primary current transformer.

Example 12: Scaling of the phase current measurement.

The nominal current of the primary side of the primary current transformers is 400 A. The current must be given in amperes. The scaling factor is 400.00.

```
>99WS9:400.00:XX
; Set scaling factor S9 to 400.00
>99WV151:1:XX
; Store the programmed parameters
```

The scaling factor can be programmed within the range 0.00...10000.00. The default value of variable S9 after factory testing is 200.00.

Active and reactive power

The value of the active power is displayed locally and transferred in actual megawatts via the serial bus. Correspondingly the value of the reactive power is displayed locally and transferred in actual megavars via the serial bus. Both negative and positive power values can be measured.

The power measurement is enabled or disabled by means of parameter S91. As a default power measurement is disabled (S91=0). The input signal range of the mA-inputs is -20...20 mA.

The following setting parameters are used for scaling the inputs:

- S12 = Low limit of the mA signal related to active power, sign
- S13 = High limit of the mA signal related to active power, sign
- S14 = Low limit of the mA signal related to reactive power, sign
- S15 = High limit of the mA signal related to reactive power, sign
- S16 = Value of active power corresponding to the mA signal at low limit, sign
- S17 = Value of active power corresponding to the mA signal at high limit, sign
- S18 = Value of reactive power corresponding to the mA signal at low limit, sign
- S19 = Value of reactive power corresponding to the mA signal at high limit, sign

After the power measurement has been enabled the low and high limits of the mA signals are given and then the corresponding values of active and reactive power.

Example 13: The scale of the measured active power ranges from -50 to 135 MW and the corresponding mA range is -20...20 mA.

```
>99WS91:1:XX
; Enable power measurement
>99WS12:-20:XX
; Set low limit of the mA signal
>99WS13:+20:XX
; Set high limit of the mA signal
>99WS16:-50.00:XX
; Set value of power corresponding to
the mA signal -20 mA
>99WS17:+135.00:XX
; Set value of power corresponding to
the mA signal 20 mA
>WV151:1:XX
; Store the programmed parameters
```

Example 14: The scale of the measured reactive power ranges from 0 to 2.2 Mvar and the corresponding mA range is 4...20 mA.

```
>99WS91:1:XX
; Enable power measurement
>99WS14:+4:XX
; Set the low limit of the mA signal
>99WS15:+20:XX
; Set the high limit of the mA signal
>99WS18:+0.00:XX
; Set the value of power corresponding
to the mA signal 4 mA
>99WS19:+2.20:XX
; Set the value of the power corresponding
to the mA-signal 20 mA
>99WV151:1:XX
; Store the programmed parameters
```

The scaled active and reactive power can be transmitted to the remote control system as SPA-bus variables V3 and V4 for the active power and reactive power respectively.

Energy

Input channel 7 can be used for counting energy pulses. The measured energy is displayed locally by three digits in three parts; in kilowatthours, in megawatthours and in gigawatthours. Correspondingly, the energy value can be read via the serial bus in three parts with maximum three digits (parameters V8...V10) but also in one part in kilowatthours with maximum nine digits (parameter V5). Before the pulse counter can be used the energy measurement must be enabled by variable S92. As a default energy is not measured (S92=0).

The following parameters must be defined for channel 7:

S1 = definition of channel 7
 0 = general ON/OFF input (default)
 1 = pulse counter without local indication with front panel LED
 2 = pulse counter with local indication with front panel LED

S2 = pulse direction
 0 = negative pulse
 1 = positive pulse (default)

The following parameters must be defined for channel 0:

S3 = definition of kWh value per pulse, range 0.01...1000 kWh per pulse. Default value is 1.

Example 15: Measurement of energy via the pulse counter.

```
>99WS92:1:XX
; Enable energy measurement
>99WS3:5:XX
; Set energy value 5 kWh per pulse
>99W7S1:1:XX
; Set input 7 as a pulse counter without
local indication
>99W7S2:1:XX
; Set a positive polarity of pulses
>99WV151:1:XX
; Store the programmed parameters
```

The energy can also be integrated by using the measured active and reactive power. In this case the measured active energy in one direction is displayed locally whereas the measured active and reactive energy can be read in both directions via the serial bus.

The integration is used automatically if the energy measurement is enabled by parameter S92 but input channel 7 is not defined as a pulse counter.

Example 16: Measurement of energy by integrating the measured power. Initially the measurement of power must be enabled and scaled, see examples 13 and 14.

```
>99WS92:1:XX
; Enable energy measurement
>99WV151:1:XX
; Store the programmed parameters
```

Event codes

Over the SPA bus substation level data communicator can read the event data, change in status, produced by the control module SPTO 1D2. The events are represented by the event codes e.g. E1...E11. The control module transmits its event data in the format:

<time> <channel number><event code>

where time = ss.sss (seconds and parts of second)
channel number = 0...13
event code = E1...E54, depending on the channel

Most of the event codes and the events represented by these may be included in or excluded from the event reporting by writing an event mask (V155) to the module. The event mask is a binary number coded to a decimal number. Each channel (0...13) has its own event mask.

Each event code is represented by a number. An event mask is formed by multiplying the number either by 1, which means that event is included in the reporting, or by 0, which means that event is not included in the reporting, and finally adding up the results of multiplications.

Example 17: Calculation of the event mask.

Channel	Event code	Event	Number representing the event	Event factor	Result of multiplication
2	E1	Change in status: xx ->10 (open)	1	x 1	= 1
2	E2	Change in status: xx ->01 (close)	2	x 1	= 2
2	E3	Change in status: xx ->11 (undefined)	4	x 0	= 0
2	E4	Change in status: xx ->00 (undefined)	8	x 1	= 8
2	E5	OPEN output activated	16	x 1	= 16
2	E6	OPEN output reset	32	x 0	= 0
2	E7	CLOSE output activated	64	x 1	= 64
2	E8	CLOSE output reset	128	x 0	= 0
2	E9	Output activation inhibited	256	x 1	= 256
2	E10	Output activation fault	512	x 0	= 0
2	E11	Attempt to activate an output without open/close selection	1024	x 0	= 0
Event mask V155 for channel 2					347

The event mask V155 of channel 0 and channels 4...13 may have a value within the range 0...15 and the event mask of channels 1...3 within the range 0...2047. The default values are shown in the next table.

Channels 1...13 have a setting S20, which enables or inhibits the event reporting of the corresponding channel. The default value is 0, which means that event reporting is allowed according to event mask.

The settings S10...S13 for channels 1...3 and settings S10 and S11 for channels 4...13 define the event delays. The event delays are used for filtering out unwanted events when status data is changing. An event code is generated only if the status data is stable for a longer time than the corresponding delay time, e.g. the event code E4 "change in status: xx -> 00" can be filtered out when the status of an object is changing from open to close and vice versa. The time marking of a delayed event is the actual event time added with the delay time.

The control module has the following event codes:

Channel	Code	Event	Number representing event	Default value of event factor
0	E1	Key switch to LOCAL position	1	1
0	E2	Key switch to REMOTE position	2	1
0	E3	Output test switch SG1/1 ON	4	0
0	E4	Output test switch SG1/1 OFF	8	0

V155 = 3

1...3	E1	Change in status; xx -> 10 (open)	1	1
1...3	E2	Change in status; xx -> 01 (closed)	2	1
1...3	E3	Change in status; xx ->11 (undefined)	4	0
1...3	E4	Change in status; xx ->00 (undefined)	8	0
1...3	E5	OPEN output activated	16	1
1...3	E6	OPEN output reset	32	0
1...3	E7	CLOSE output activated	64	1
1...3	E8	CLOSE output reset	128	0
1...3	E9	Output activation inhibited 1)	256	1
1...3	E10	Output activation fault 2)	512	1
1...3	E11	Trying to activate an output without open/close selection 3)	1024	1

V155 = 1875

4...13	E1	Input channel activated	1	1
4...13	E2	Input channel reset	2	1
4...13	E3	SIGNAL1...3 output activated	4	0
4...13	E4	SIGNAL1...3 output reset	8	0

V155 = 3

0	E50	Restarting	*	-
0	E51	Overflow of event register	*	-
0	E52	Temporary disturbance in data communication	-	-
0	E53	No response from the module over the data communication	*	-
0	E54	The module responds again over the data communication	*	-

0 not included in the event reporting

1 included in the event reporting

* no code number

- cannot be programmed

In the SPACOM system the event codes E52...E54 are formed by the station level control data communicator.

- 1) Event E9, output activation inhibited, is given when the operation is inhibited by the interlocking program or by an input channel 4...13.
- 2) Event E10, output activation fault, is given if the status of the controlled object does not change during the time of the output pulse.
- 3) Event E11, attempt to activate an output without an open/close selection, is given when a secured control is made in a situation where the state of alert has not been defined.

If all the parameters are programmed at the same time the following instructions should be used when changing between program and run mode and when storing the parameters.

As a default the parameters related to interlocking and configuration have the following values:

S100 = 1
Default configuration and interlocking 1
S198 = 1
The interlocking program is in run mode
S199 = 1
Interlockings are in use

The following examples illustrate the programming.

Example 18: Select another configuration and interlocking than default 1.

```
>99WS198:0:XX  
    ; Change into program mode  
>99WS100:2:XX  
    ; Select the default 2  
>99WS198:1:XX  
    ; Change into run mode  
.  
    ; Change other parameters  
.  
.  
>99WV151:1:XX  
    ; Store the programmed parameters
```

Example 19: Select a user defined configuration and interlocking.

```
>99WS198:0:XX  
    ; Change into program mode  
>99WS100:0:XX  
    ; Change into freely programmable mode  
>99WS101:...  
    ; Configuration commands  
.  
.  
.  
>99WM200:...  
    ; Interlocking program  
.  
.  
.  
>99WS198:1:XX  
    ; Change into run mode  
.  
    ; Change other parameters  
.  
.  
>99WV151:1:XX  
    ; Store the programmed parameters
```

Serial communication parameters

Apart from the event codes the substation level data communicator is able to read, over the SPA-bus, all input data (I-data) of the module, setting values (S-data), information recorded in

the memory (V-data), and some other data. Further, part of the data can be altered by commands given over the SPA-bus.

Data	Channel	Code	Data direction	Values
Current in phase L1 (x I _n)	0	I1	R	0.00...2.50 x I _n
Current in phase L2 (x I _n)	0	I2	R	0.00...2.50 x I _n
Current in phase L3 (x I _n)	0	I3	R	0.00...2.50 x I _n
Active power (bits)	0	I4	R	-1023...1023 bits
Reactive power (bits)	0	I5	R	-1023...1023 bits
Current in phase L1 (A)	0	I6	R	0...9999 A
Current in phase L2 (A)	0	I7	R	0...9999 A
Current in phase L3 (A)	0	I8	R	0...9999 A
Status of an object	1...3	I1	R	0 = undefined (inputs 00) 1 = closed 2 = open 3 = undefined (inputs 11)
Closed status of an object	1...3	I2	R	0 = not closed 1 = closed
Open status of an object	1...3	I3	R	0 = not open 1 = open
Status of inputs 4...13	4...13	I1	R	0 = not active 1 = active
Direct output write	1...3	O1	W	0 = open 1 = close
Open select (secured operation)	1...3	V1	RW	0 = non select 1 = select
Close select (secured operation)	1...3	V2	RW	0 = non select 1 = select
Execute selected open/close operation	1...3	V3	W	1 = execute selected operation
Cancel selected open/close operation	1...3	V4	W	1 = cancel selected operation
Open pulse length	1...3	V5	RW(e)	0.1...100.0 s
Close pulse length	1...3	V6	RW(e)	0.1...100.0 s
Execute selected open/close operation (common addr. 900)	0	V251	W	1 = execute all selected operations
Cancel selected open/close operations (common addr. 900)	0	V252	W	1 = cancel all selected operations
kWh value per pulse	0	S3	RW(e)	0.01...1000 kWh per pulse
Position of switch SG1/1	0	S6	R	0 = operation position (SG1/1=0) 1 = interlockings off (SG1/1=1)
Object indication mode	0	S7	RW(e)	0 = continuous display 1 = automatic switch-off after 10 min.
Display indication mode	0	S8	RW(e)	0 = continuous display 1 = automatic switch-off after 5 min.

Data	Channel	Code	Data direction	Values
Scaling of current measurement	0	S9	RW(e)	0.00...10000.00
Low limit for mA signal of active power	0	S12	RW(e)	-20...+20 mA
High limit for mA signal of active power	0	S13	RW(e)	-20...+20 mA
Low limit for mA signal of react. power	0	S14	RW(e)	-20...+20 mA
High limit for mA signal of react. power	0	S15	RW(e)	-20...+20 mA
Active power corresponding to the mA signal at low limit	0	S16	RW(e)	- 999.99...+999.99
Active power corresponding to the mA signal at high limit	0	S17	RW(e)	- 999.99...+999.99
Reactive power corresponding to the mA signal at low limit	0	S18	RW(e)	- 999.99...+999.99
Reactive power corresponding to the mA signal at high limit	0	S19	RW(e)	- 999.99...+999.99
Power measurement	0	S91	RW(e)	0 = no power measurement 1 = power is measured
Energy measurement	0	S92	RW(e)	0 = no energy measurement 1 = energy is measured
Configuration and interlocking	0	S100	RW(e)	0 = freely programmable configuration and interlocking program 1 = default 1 2 = default 2 10 = default 10
Configuration of objects (format; value 1, value 2, input No, output No, value 3)	0	S101 : S116	RW(e)	- value 1; 0 = indicator not used 1 = indicator used - value 2; 0 = vertical LEDs indicate open status 1 = vertical LEDs indicate closed status - input number; 1...3=input number 1...3 - output number; 0 = not controlled object 20 or 21 = outputs 20 and 21 used - value 3; 0 =object other than a CB 1 = object is a CB
Program/run mode selection	0	S198	RW(e)	0 = program mode 1 = run mode
Interlocking selection	0	S199	RW(e)	0 = no interlockings 1 = interlockings in use 2 = for future use

Data	Channel	Code	Data direction	Values
Interlocking and Conditional Direct Output Control program (format; operation, operand)	0	M200 : M300	RW(e)	operation = LOAD, LOADN AND, ANDN OR, ORN OUT END operands for interlocking = status closed (1...3) or active (4...13) status undefined (101...103) status open (201...203) No. of output (20 or 21) No. of memory (70...89) operands for Conditional Direct Output Control = status closed (1...3) or active (4...13) status undefined (101...103) status open (201...203) No of output (22...24, 220 or 221) No of memory (70...89)
Event delay; —>10 (open)	1...3	S10	RW(e)	0.0, or 0.1...60.0 s
Event delay; —>01 (close)	1...3	S11	RW(e)	0.0, or 0.1...60.0 s
Event delay; —>11 (undefined)	1...3	S12	RW(e)	0.0, or 0.1...60.0 s
Event delay; —>00 (undefined)	1...3	S13	RW(e)	0.0, or 0.1...60.0 s
Use of input 7	7	S1	RW(e)	0 = general mode 1 = pulse counter without indication 2 = pulse counter with indication
Operation direction of inputs 4...13	4...13	S2	RW(e)	0 = active at low state 1 = active at high state
Signal output activation by inputs 4...13	4...13	S3	RW(e)	0 = no SIGNAL output 22 = SIGNAL1 output is activated 23 = SIGNAL2 output is activated 24 = SIGNAL3 output is activated
Operation of OPEN and CLOSE outputs by inputs 4...13	4...13	S4	RW(e)	0 = no activation or inhibit output 20 = activate OPEN output 21 = activate CLOSE output 120 = inhibit OPEN output 121 = inhibit CLOSE output

Data	Channel	Code	Data direction	Values
Memory controlled function of the indicators of the binary inputs	4...9	S5	RW(e)	0 = not memory controlled 1 = memory controlled
Event delay; —>activated	4...13	S10	RW(e)	0.0, or 0.1...60.0 s
Event delay; —>reset	4...13	S11	RW(e)	0.0, or 0.1...60.0 s
Event reporting	1...13	S20	RW(e)	0 = event reporting enabled 1 = event reporting inhibited
Active power (MW)	0	V3	R	-999.99...+999.99 MW
Reactive power (Mvar)	0	V4	R	-999.99...+999.99 Mvar
Active energy (kWh)	0	V5	RW	0...999999999 kWh
Status of the local/remote key switch	0	V6	R	0 = local 1 = remote
Active energy (kWh)	0	V8	RW	0...999 kWh
Active energy (MWh)	0	V9	RW	0...999 MWh
Active energy (GWh)	0	V10	RW	0...999 GWh
Active energy; reversed (kWh)	0	V11	RW	0...999 kWh
Active energy; reversed (MWh)	0	V12	RW	0...999 MWh
Active energy; reversed (GWh)	0	V13	RW	0...999 GWh
Reactive energy (kvarh)	0	V14	RW	0...999 kvarh
Reactive energy (Mvarh)	0	V15	RW	0...999 Mvarh
Reactive energy (Gvarh)	0	V16	RW	0...999 Gvarh
Reactive energy; reversed (kvarh)	0	V17	RW	0...999 kvarh
Reactive energy; reversed (Mvarh)	0	V18	RW	0...999 Mvarh
Reactive energy; reversed (Gvarh)	0	V19	RW	0...999 Gvarh
Data store into EEPROM	0	V151	W	1 = store, takes about 5 s
Load default values after EEPROM failure	0	V152	RW(e)	0 = enable to load default values 1 = inhibit to load default values
Event mask	0	V155	RW(e)	0...15
Event mask	1...3	V155	RW(e)	0...2047
Event mask	4...13	V155	RW(e)	0...15
Activation of self-supervision output	0	V165	W	0 = reset 1 = activate
Internal fault code	0	V169	R	Fault code
Data communication address	0	V200	RW(e)	1...255
Data transfer rate	0	V201	RW(e)	4800, 9600
Program version symbol	0	V205	R	E.g. 054 A

Data	Channel	Code	Data direction	Values
Type designation of the module	0	F	R	SPTO 1D2
Reading of event register	0	L	R	Time, channel number and event code
Re-reading of event register	0	B	R	Time, channel number and event code
Reading of module status information	0	C	R	0 = normal state 1 = module been subject to automatic reset 2 = overflow of event register 3 = events 1 and 2 together
Resetting of module status information	0	C	W	0 = resetting
Time reading and setting	0	T	RW	0.000...59.999 s

R = Data which can be read from the unit

W = Data which can be written to the unit

(e) = Data which has to be stored into EEPROM (V151) after having been changed

The data transfer codes L, B, C and T have been reserved for the event data transfer between the module and the station level data communicator.

The event register can be read by the L command only once. Should a fault occur e.g. in the data transmission, it is possible, by using the B command, to re-read the contents of the event register once read by means of the L command. When required, the B command can be repeated.

Default values of the parameters

The parameters stored in the EEPROM have been given default values after factory testing. All the default values have been stored in the EEPROM by pressing the push-buttons STEP and SELECT at the same time as the auxiliary

power supply was connected. The push-buttons have to be pressed until the display is lit.

The following table gives the default values of the parameters.

Parameter	Channel	Code	Default value
Open pulse length	2	V5	0.1 s
Close pulse length	2	V6	0.1 s
kWh value per pulse	0	S3	1 kWh per pulse
Object indication mode	0	S7	0 = continuous display
Display indication mode	0	S8	0 = continuous display
Scaling of current measurement	0	S9	200.00
Low limit of mA-signal of active power	0	S12	+4 mA
High limit of mA-signal of active power	0	S13	+20 mA
Low limit of mA-signal of react. power	0	S14	+4 mA
High limit of mA-signal of react. power	0	S15	+20 mA
Active power corresponding to the mA-signal at low limit	0	S16	+0.00
Active power corresponding to the mA-signal at high limit	0	S17	+999.99
Reactive power corresponding to the mA-signal at low limit	0	S18	+0.00
Reactive power corresponding to the mA-signal at low limit	0	S19	+999.99
Power measurement	0	S91	0 = no power measurement
Energy measurement	0	S92	0 = no energy measurement
Configuration and interlocking	0	S100	1 = default configuration and interlocking 1
Configuration of objects	0	S101 : S116	default configuration 1, see appendix 1
Program/run mode selection	0	S198	1 = run mode
Interlocking selection	0	S199	1 = interlockings in use
Interlocking program	0	M200 : M300	default interlocking 1, see appendix 1
Event delay; —>10 (open)	1...3	S10	0.0 s
Event delay; —>01 (close)	1...3	S11	0.0 s
Event delay; —>00, —>11	1 and 3	S12	10.0 s
Event delay; —>00, —>11	2	S12	0.2 s
Use of input 7	7	S1	0 = general mode
Operation direction of inputs 4...13	4...13	S2	1 = active at high state
Signal output activation by inputs 4...13	4...13	S3	0 = no signal output
Operation of OPEN and CLOSE outputs by inputs 4...13	4...13	S4	0 = no activation or inhibit
Memory controlled function of the indicators of the binary inputs	4...9	S5	0 = not memory controlled

Parameter	Channel	Code	Default value
Event delay; —>activated	4...13	S10	0.0 s
Event delay; —>reset	4...13	S11	0.0 s
Event reporting	1...13	S20	0 = event reporting enabled
Load default values after EEPROM failure	0	V152	1 = inhibited
Event mask	0	V155	3
Event mask	1...3	V155	1875
Event mask	4...13	V155	3
Data communication address	0	V200	99
Data transfer rate	0	V201	9600

Technical data

Control functions

- status indication for maximum 3 objects, e.g. circuit breakers, disconnectors, earth switches
- configuration freely programmable by the user
- remote or local control (open and close) for one object
- output pulse length programmable, 0.1...100.0 s
- 10 other binary inputs to read contact data other than status information
- feeder oriented interlocking freely programmable, the 3 status inputs and 10 other binary inputs may be included
- the 10 binary inputs may be used to operate the OPEN and CLOSE outputs
- three signal outputs, can be controlled by the 10 binary inputs

Measurements

- measurement of three phase currents
- phase current measuring range $0...2.5 \times I_n$
- phase current measuring accuracy better than $\pm 1\%$ of I_n
- two mA inputs for measuring active and reactive power
- mA input range -20...20 mA, can be limited by programming
- power measuring accuracy better than $\pm 1\%$ of maximum value of measuring range
- one pulse counter input for energy pulse counting, maximum frequency 25 Hz
- energy can also be calculated on the basis of measured power
- all measured values can be scaled to actual primary values
- local display or remote reading of measured values

Appendix 1

Default configuration and interlocking 1

Default configuration and interlocking 1 is selected by giving variable S100 the value 1. The other parameters have the values given in the chapter "Default values of the parameters"

Configuration

The configuration has three objects, a circuit breaker, a circuit breaker truck and an earth-switch. The close state is indicated with red colour and the open state with green colour. The following inputs, indicators and outputs are used:

- Circuit breaker;
 - input channel 2, indicator 110, controlled by OPEN (20) and CLOSE (21) output
- Circuit breaker truck;
 - input channel 1, indicator 109, not controlled
- Earth-switch;
 - input channel 3, indicator 116, not controlled

The configuration commands are:

S109:1,1,1,0,0
 S110:1,1,2,20,1
 S116:1,0,3,0,0

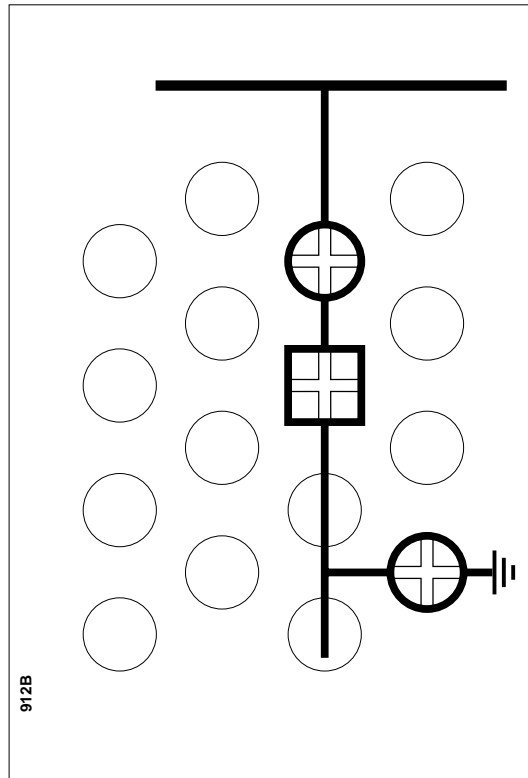

Fig. 14. Default configuration 1.

Interlocking

The following rules apply for interlocking:

- The CB can always be opened.
- The CB can be closed if the CB truck is in the isolated position or if the CB truck is in the service position and the earth-switch is open.

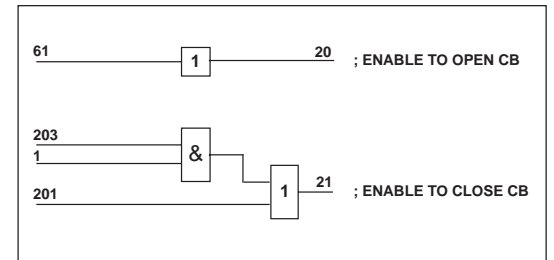

Fig. 15. Logic diagram for the default interlocking 1.

The interlocking program has the following formula:

M200:LOAD 61
 M201:OUT 20
 M202:LOAD 1
 M203:AND 203
 M204:OR 201
 M205:OUT 21
 M206:END

Appendix 2

Default configuration and interlocking 2

Default configuration and interlocking 2 is selected by giving variable S100 the value 2. The other parameters have the values given in the chapter "Default values of the parameters"

Configuration

The configuration has three objects, a circuit breaker, a circuit breaker truck and an earth-switch. The close state is indicated with red colour and the open state with green colour. The following inputs, indicators and outputs are used:

- Circuit breaker;
 - input channel 2, indicator 110, controlled by OPEN (20) and CLOSE (21) output
- Circuit breaker truck;
 - input channel 1, indicator 109, not controlled
- Earth-switch;
 - input channel 3, indicator 116, not controlled

The configuration commands are:

S109:1,1,1,0,0
 S110:1,1,2,20,1
 S116:1,0,3,0,0

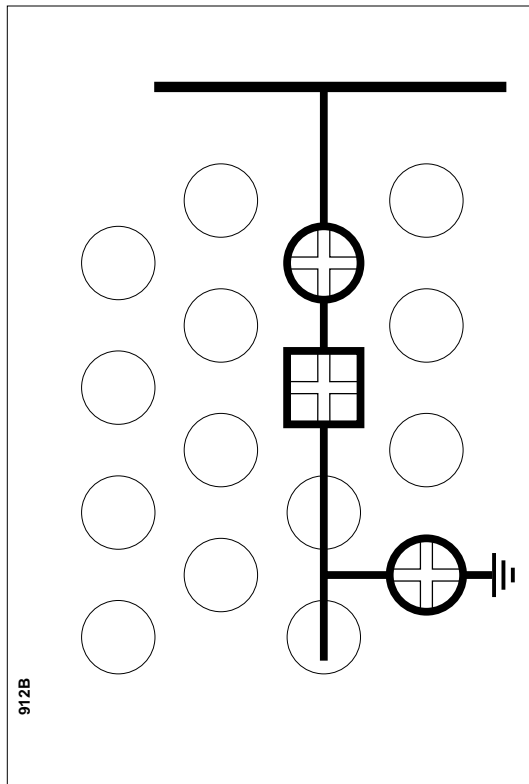

Fig. 16. Default configuration 2.

Interlocking

The following rules apply for interlocking:

- The CB can always be opened.
- The CB can be closed if the CB truck is in service position, the CB is open and the earth-switch is open.

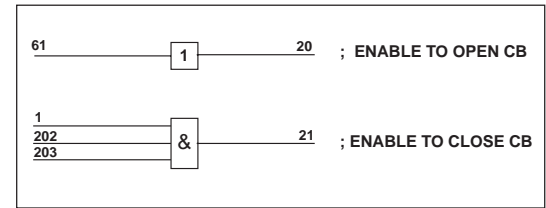

Fig. 17. Logic diagram for the default interlocking 2.

The interlocking program has the following formula:

```
M200:LOAD 61
M201:OUT 20
M202:LOAD 1
M203:AND 202
M204:AND 203
M205:OUT 21
M206:END
```

Appendix 3

Default configuration and interlocking 10

Default configuration and interlocking 10 is selected by giving variable S100 the value 10. The other parameters have the values given in the chapter "Default values of the parameters".

Configuration

The configuration has three objects, a circuit breaker, a circuit breaker truck and an earth-switch. The close state is indicated with green colour and the open state with red colour. This default is the same as default 1, but the colours of the object indicators are reversed. The following inputs, indicators and outputs are used:

- Circuit breaker;
 - input channel 2, indicator 107, controlled by OPEN (20) and CLOSE (21) output
- Circuit breaker truck;
 - input channel 1, indicator 106, not controlled
- Earth-switch;
 - input channel 3, indicator 104, not controlled

The configuration commands are:

S106:1,1,1,0,0
 S107:1,1,2,20,1
 S104:1,0,3,0,0

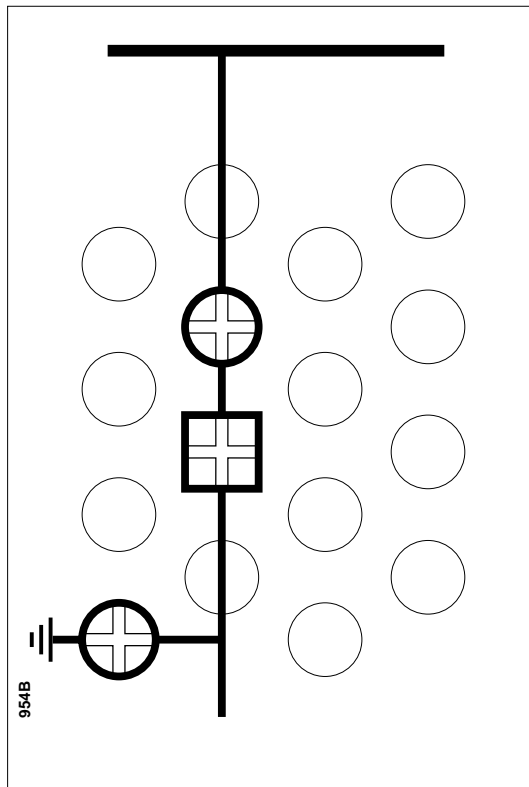

Fig. 18. Default configuration 10.

Interlocking

The interlocking is defined with the following rules:

- The CB can always be opened.
- The CB can be closed if the CB truck is in the isolated position or if the CB truck is in the service position and the earth-switch is open.

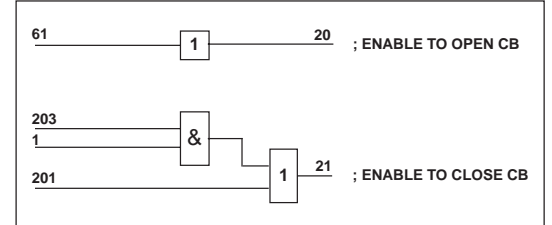

Fig. 19. Logic diagram for the default interlocking 10.

The interlocking program has the following formula:

```
M200:LOAD 61
M201:OUT 20
M202:LOAD 1
M203:AND 203
M204:OR 201
M205:OUT 21
M206:END
```

General characteristics of D-type relay modules

User's manual and Technical description

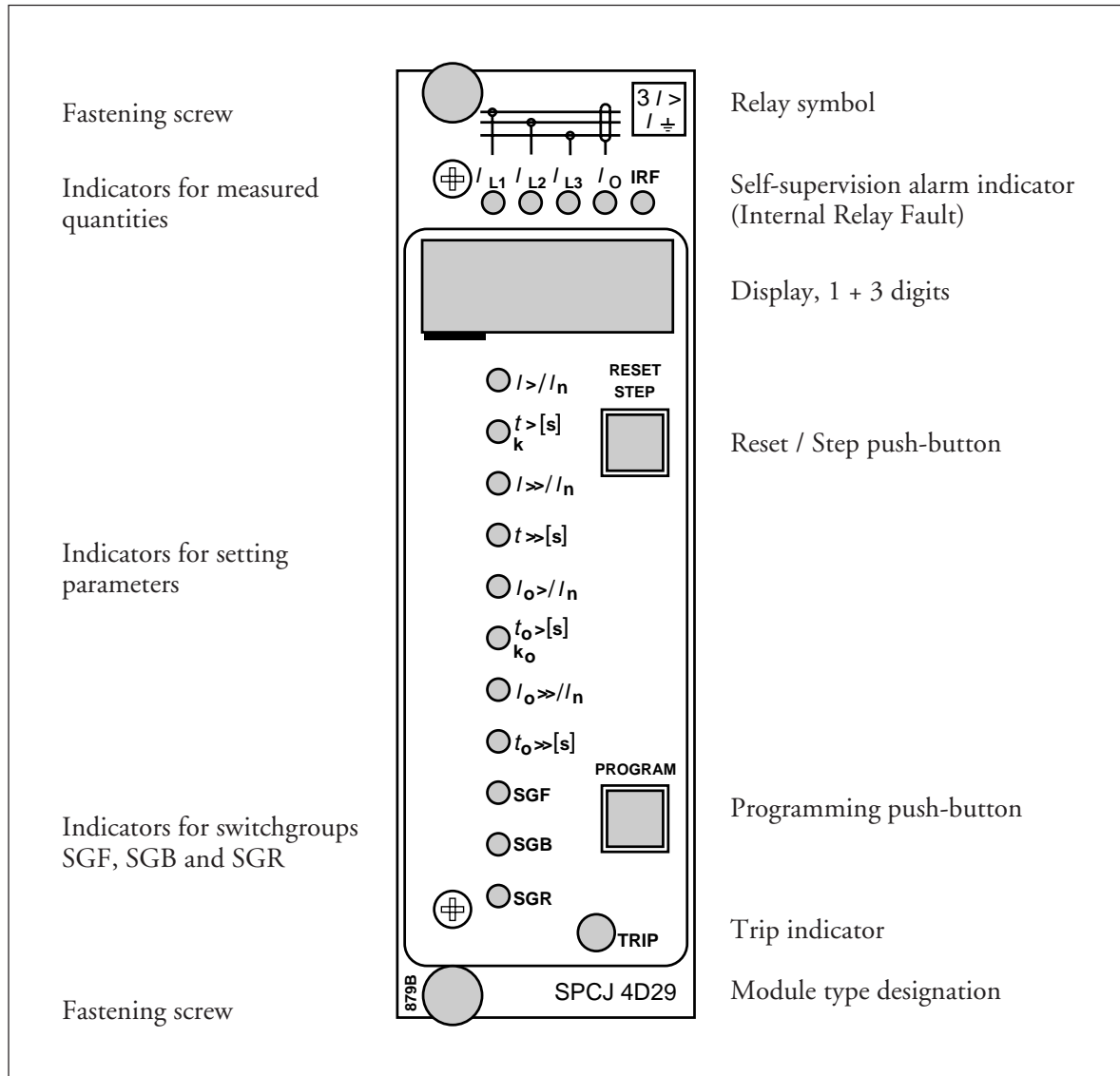

General characteristics of D type relay modules

Data subject to change without notice

Contents

Front panel lay-out	1
Control push buttons	3
Display	3
Display main menu	3
Display submenus	3
Selector switchgroups SGF, SGB, SGR	4
Settings	4
Setting mode	4
Example 1: Setting of relay operation values	7
Example 2: Setting of relay switchgroups	9
Recorded information	11
Trip test function	12
Example 3: Forced activation of outputs	13
Operation indicators	15
Fault codes	15

Control push-buttons	<p>The front panel of the relay module contains two push buttons. The RESET / STEP push button is used for resetting operation indicators and for stepping forward or backward in the display main menu or submenus. The PROGRAM push button is used for moving from a</p>	<p>certain position in the main menu to the corresponding submenu, for entering the setting mode of a certain parameter and together with the STEP push button for storing the set values. The different operations are described in the subsequent paragraphs in this manual.</p>
Display	<p>The measured and set values and the recorded data are shown on the display of the protection relay module. The display consists of four digits. The three green digits to the right show the measured, set or recorded value and the leftmost red digit shows the code number of the register. The measured or set value displayed is indicated by the adjacent yellow LED indicator on the front panel. When a recorded fault value is being displayed the red digit shows the number of the corresponding register. When the display functions as an operation indicator the red digit alone is shown.</p>	<p>When the auxiliary voltage of a protection relay module is switched on the module initially tests the display by stepping through all the segments of the display for about 15 seconds. At first the corresponding segments of all digits are lit one by one clockwise, including the decimal points. Then the center segment of each digit is lit one by one. The complete sequence is carried out twice. When the test is finished the display turns dark. The testing can be interrupted by pressing the STEP push button. The protection functions of the relay module are alerted throughout the testing.</p>
Display main menu	<p>Any data required during normal operation are accessible in the main menu i.e. present measured values, present setting values and recorded parameter values.</p> <p>The data to be shown in the main menu are sequentially called up for display by means of the STEP push button. When the STEP push button is pressed for about one second, the display moves forward in the display sequence. When the push button is pressed for about 0.5 seconds, the display moves backward in the display sequence.</p>	<p>From a dark display only forward movement is possible. When the STEP push button is pushed constantly, the display continuously moves forward stopping for a while in the dark position.</p> <p>Unless the display is switched off by stepping to the dark point, it remains lit for about 5 minutes from the moment the STEP push button was last pushed. After the 5 minutes' time-out the display is switched off.</p>
Display submenus	<p>Less important values and values not very often set are displayed in the submenus. The number of submenus varies with different relay module types. The submenus are presented in the description of the concerned protection relay module.</p> <p>A submenu is entered from the main menu by pressing the PROGRAM push button for about one second. When the push button is released, the red digit of the display starts flashing, indicating that a submenu has been entered. Going from one submenu to another or back to the main menu follows the same principle as when moving from the main menu display to another;</p>	<p>the display moves forward when the STEP push button is pushed for one second and backward when it is pushed for 0.5 seconds. The main menu has been re-entered when the red display turns dark.</p> <p>When a submenu is entered from a main menu of a measured or set value indicated by a LED indicator, the indicator remains lit and the address window of the display starts flashing. A submenu position is indicated by a flashing red address number alone on the display without any lit set value LED indicator on the front panel.</p>

Selector switch-groups SGF, SGB and SGR

Part of the settings and the selections of the operation characteristic of the relay modules in various applications are made with the selector switchgroups SG_. The switchgroups are software based and thus not physically to be found in the hardware of the relay module. The indicator of the switchgroup is lit when the checksum of the switchgroup is shown on the display. Starting from the displayed checksum and by entering the setting mode, the switches can be set one by one as if they were real physical switches. At the end of the setting procedure, a checksum for the whole switchgroup is shown. The checksum can be used for verifying that the switches have been properly set. Fig. 2 shows an example of a manual checksum calculation.

When the checksum calculated according to the example equals the checksum indicated on the display of the relay module, the switches in the concerned switchgroup are properly set.

Switch No	Pos.		Weight	Value
1	1	x	1	= 1
2	0	x	2	= 0
3	1	x	4	= 4
4	1	x	8	= 8
5	1	x	16	= 16
6	0	x	32	= 0
7	1	x	64	= 64
8	0	x	128	= 0
Checksum			Σ	= 93

Fig. 2. Example of calculating the checksum of a selector switchgroup SG_.

The functions of the selector switches of the different protection relay modules are described in detail in the manuals of the different relay modules.

Settings

Most of the start values and operate times are set by means of the display and the push buttons on the front panel of the relay modules. Each setting has its related indicator which is lit when the concerned setting value is shown on the display.

In addition to the main stack of setting values most D type relay modules allow a second stack of settings. Switching between the main settings

and the second settings can be done in three different ways:

- 1) By command V150 over the serial communication bus
- 2) By an external control signal BS1, BS2 or RRES (BS3)
- 3) Via the push-buttons of the relay module, see submenu 4 of register A.

Setting mode

Generally, when a large number of settings is to be altered, e.g. during commissioning of relay systems, it is recommended that the relay settings are entered with the keyboard of a personal computer provided with the necessary software. When no computer nor software is available or when only a few setting values need to be altered the procedure described below is used.

The registers of the main menu and the submenus contain all parameters that can be set. The settings are made in the so called setting mode, which is accessible from the main menu or a submenu by pressing the PROGRAM push button, until the whole display starts flashing. This position indicates the value of the parameter before it has been altered. By pressing the PROGRAM push button the programming sequence moves forward one step. First the rightmost digit starts flashing while the rest of the display is steady. The flashing digit is set by means of the STEP push button. The flashing

cursor is moved on from digit to digit by pressing the PROGRAM push button and in each stop the setting is performed with the STEP push button. After the parameter values have been set, the decimal point is put in place. At the end the position with the whole display flashing is reached again and the data is ready to be stored.

A set value is recorded in the memory by pressing the push buttons STEP and PROGRAM simultaneously. Until the new value has been recorded a return from the setting mode will have no effect on the setting and the former value will still be valid. Furthermore *any attempt to make a setting outside the permitted limits for a particular parameter will cause the new value to be disqualified and the former value will be maintained.* Return from the setting mode to the main menu or a submenu is possible by pressing the PROGRAM push button until the green digits on the display stop flashing.

NOTE! During any local man-machine communication over the push buttons and the display on the front panel a five minute time-out function is active. Thus, if no push button has been pressed during the last five minutes, the relay returns to its normal state automatically. This means that the display turns dark, the relay escapes from a display mode, a programming routine or any routine going on, when the relay is left untouched. This is a convenient way out of any situation when the user does not know what to do.

Before a relay module is inserted into the relay case, one must assure that the module has been given the correct settings. If there however is

any doubt about the settings of the module to be inserted, the setting values should be read using a spare relay unit or with the relay trip circuits disconnected. If this cannot be done the relay can be set into a non-tripping mode by pressing the PROGRAM push button and powering up the relay module simultaneously. The display will show three dashes "---" to indicate the non-tripping mode. The serial communication is operative and all main and submenus are accessible. In the non-tripping mode unnecessary trippings are avoided and the settings can be checked. *The normal protection relay mode is entered automatically after a timeout of five minutes or ten seconds after the dark display position of the main menu has been entered.*

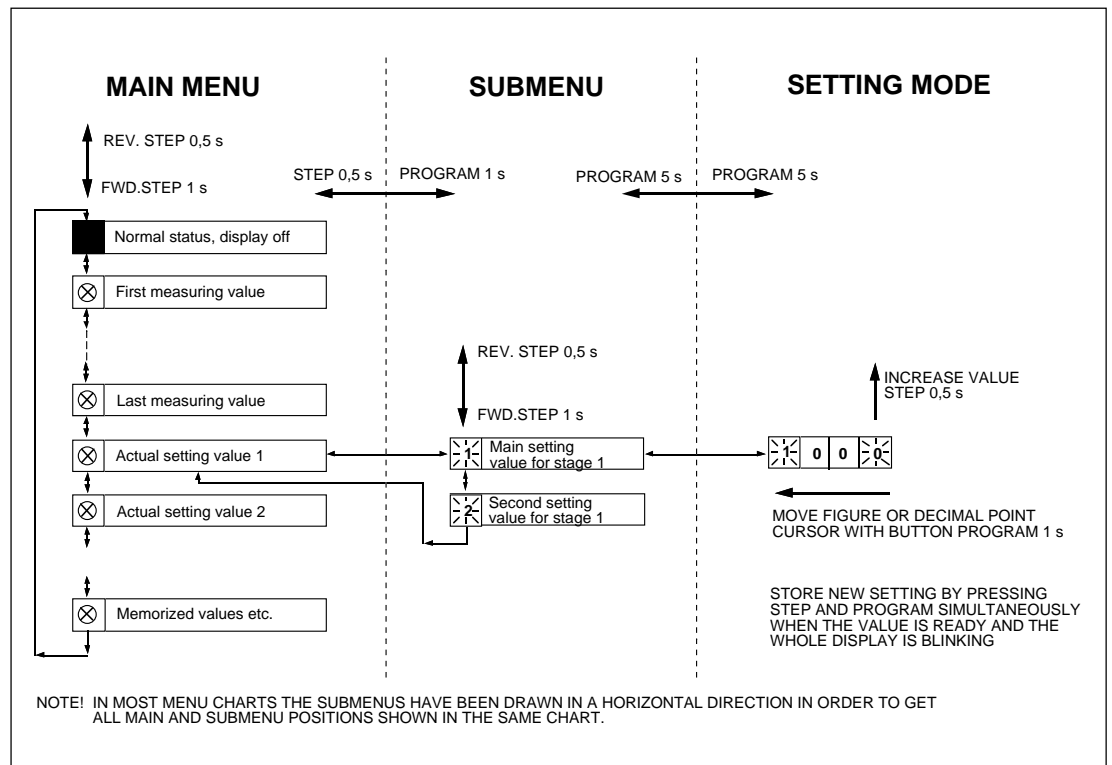

Fig.3. Basic principles of entering the main menus and submenus of a relay module.

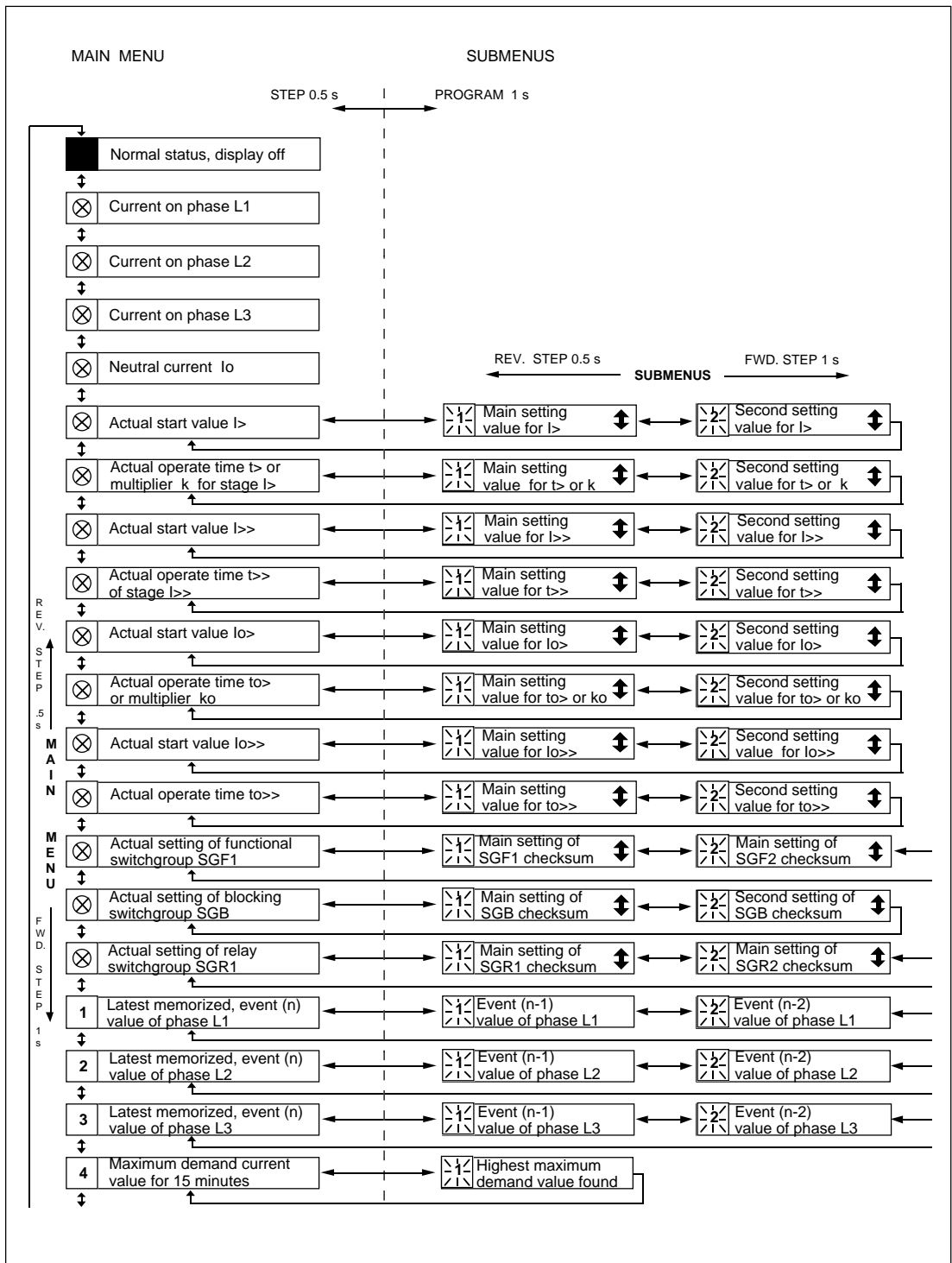

Fig. 4. Example of part of the main and submenus for the settings of the overcurrent and earth-fault relay module SPCJ 4D29. The settings currently in use are in the main menu and they are displayed by pressing the STEP push button. The main menu also includes the measured current values, the registers 1...9, 0 and A. The main and second setting values are located in the submenus and are called up on the display with the PROGRAM push button.

Example 1

Operation in the setting mode. Manual setting of the main setting of the start current value $I>$ of an overcurrent relay module. The initial value

for the main setting is $0.80 \times I_n$ and for the second setting $1.00 \times I_n$. The desired main start value is $1.05 \times I_n$.

a) Press push button STEP repeatedly until the LED close to the $I>$ symbol is lit and the current start value appears on the display.

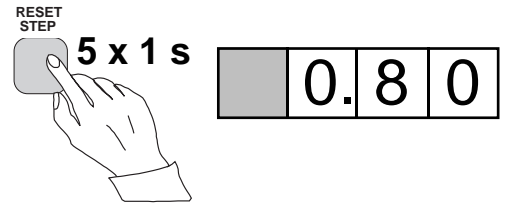

b) Enter the submenu to get the main setting value by pressing the PROGRAM push button more than one second and then releasing it. The red display digit now shows a flashing number 1, indicating the first submenu position and the green digits show the set value.

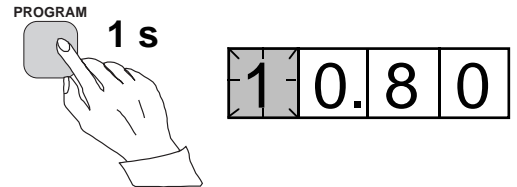

c) Enter the setting mode by pressing the PROGRAM push button for five seconds until the display starts flashing.

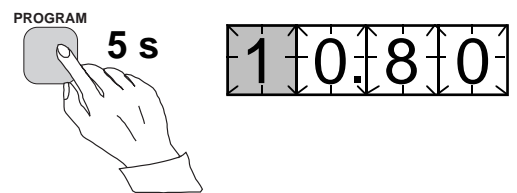

d) Press the PROGRAM push button once again for one second to get the rightmost digit flashing.

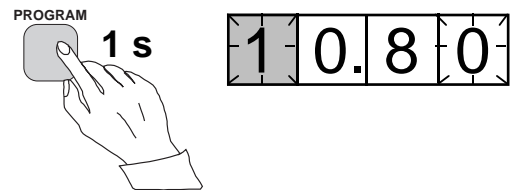

e) Now the flashing digit can be altered. Use the STEP push button to set the digit to the desired value.

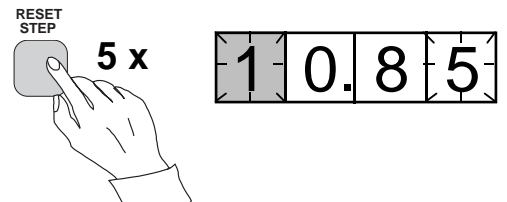

f) Press the PROGRAM push button to make the middle one of the green digits flash.

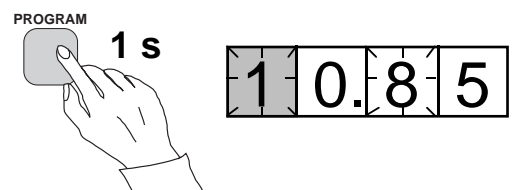

g) Set the middle digit with of the STEP push button.

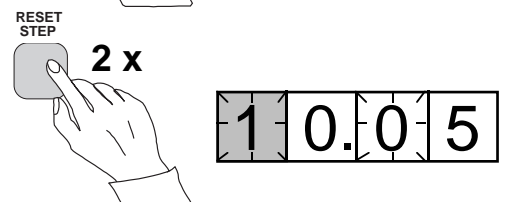

h) Press the PROGRAM push button to make the leftmost green digit flash.

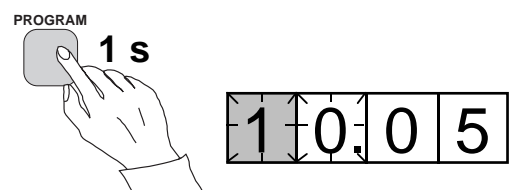

i) Set the digit with the STEP push button.

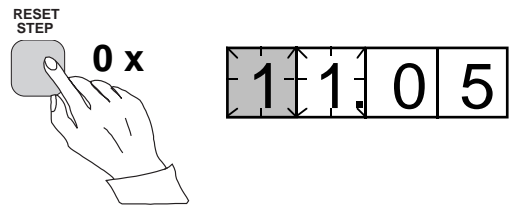

j) Press the PROGRAM push button to make the decimal point flash.

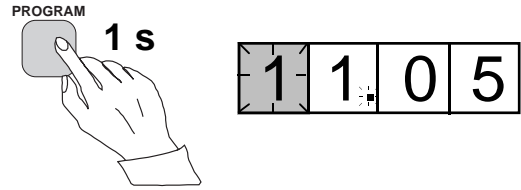

k) If needed, move the decimal point with the STEP push button.

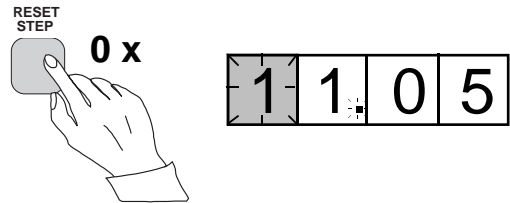

l) Press the PROGRAM push button to make the whole display flash. In this position, corresponding to position c) above, one can see the new value before it is recorded. If the value needs changing, use the PROGRAM push button to alter the value.

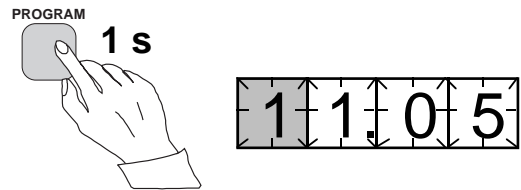

m) When the new value has been corrected, record it in the memory of the relay module by pressing the PROGRAM and STEP push buttons simultaneously. At the moment the information enters the memory, the green dashes flash once in the display, i.e. 1 - - -.

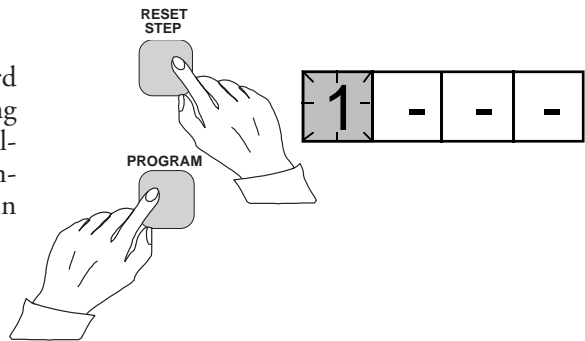

n) Recording of the new value automatically initiates a return from the setting mode to the normal submenu. Without recording one can leave the setting mode any time by pressing the PROGRAM push button for about five seconds, until the green display digits stop flashing.

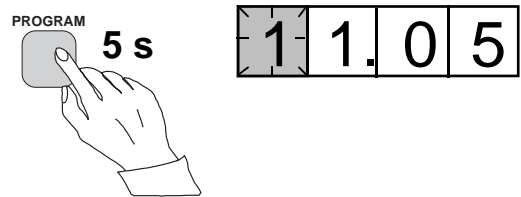

o) If the second setting is to be altered, enter submenu position 2 of the setting I> by pressing the STEP push button for approx. one second. The flashing position indicator 1 will then be replaced by a flashing number 2 which indicates that the setting shown on the display is the second setting for I>.

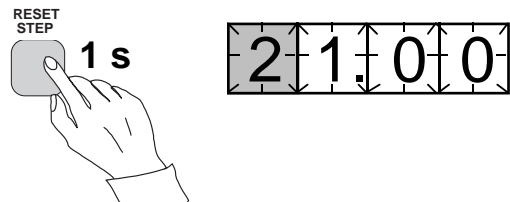

Enter the setting mode as in step c) and proceed in the same way. After recording of the requested values return to the main menu is obtained by pressing the STEP push button

until the first digit is switched off. The LED still shows that one is in the I> position and the display shows the new setting value currently in use by the relay module.

Example 2

Operation in the setting mode. Manual setting of the main setting of the checksum for the switchgroup SGF1 of a relay module. The initial value for the checksum is 000 and the switches

SGF1/1 and SGF1/3 are to be set in position 1. This means that a checksum of 005 should be the final result.

a) Press push button STEP until the LED close to the SGF symbol is lit and the checksum appears on the display.

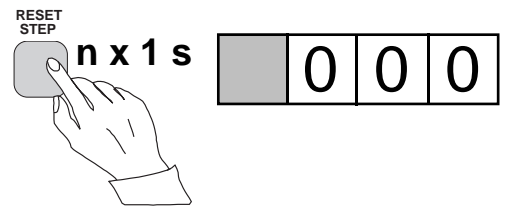

b) Enter the submenu to get the main checksum of SGF1 by pressing the PROGRAM push button for more than one second and then releasing it. The red display now shows a flashing number 1 indicating the first submenu position and the green digits show the checksum.

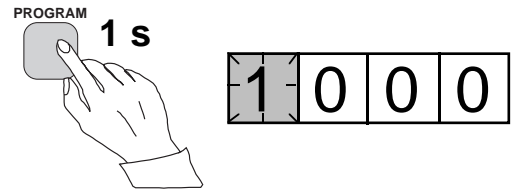

c) Enter the setting mode by pressing the PROGRAM push button for five seconds until the display starts flashing.

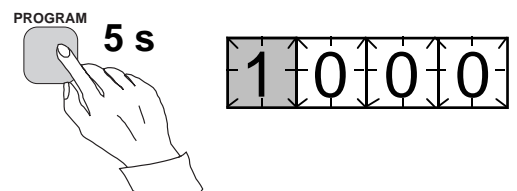

d) Press the PROGRAM push button once again to get the first switch position. The first digit of the display now shows the switch number. The position of the switch is shown by the rightmost digit.

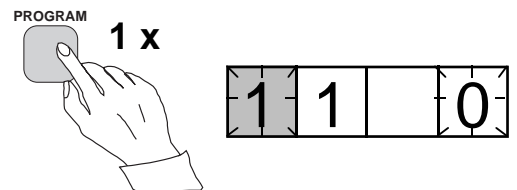

e) The switch position can now be toggled between 1 and 0 by means of the STEP push button and it is left in the requested position 1.

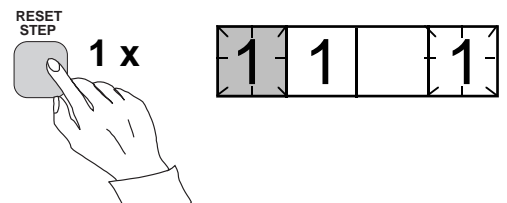

f) When switch number 1 is in the requested position, switch number 2 is called up by pressing the PROGRAM push button for one second. As in step e), the switch position can be altered by using the STEP push button. As the desired setting for SGF1/2 is 0 the switch is left in the 0 position.

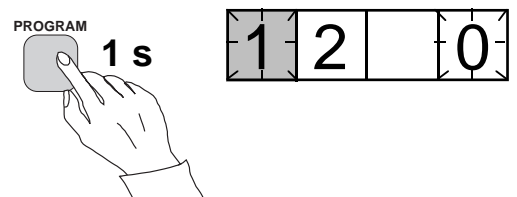

g) Switch SGF1/3 is called up as in step f) by pressing the PROGRAM push button for about one second.

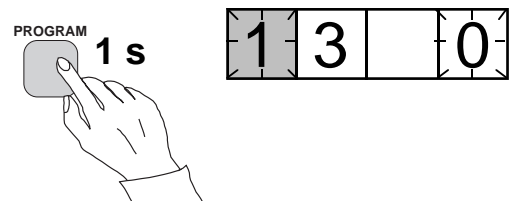

h)
The switch position is altered to the desired position 1 by pressing the STEP push button once.

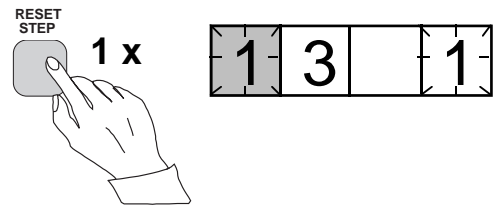

i)
Using the same procedure the switches SGF 1/4...8 are called up and, according to the example, left in position 0.

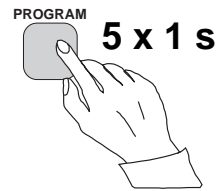

j)
In the final setting mode position, corresponding to step c), the checksum based on the set switch positions is shown.

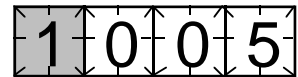

k)
If the correct checksum has been obtained, it is recorded in the memory by pressing the push buttons PROGRAM and STEP simultaneously. At the moment the information enters the memory, the green dashes flash in the display, i.e. 1 - - -. If the checksum is incorrect, the setting of the separate switches is repeated using the PROGRAM and STEP push buttons starting from step d).

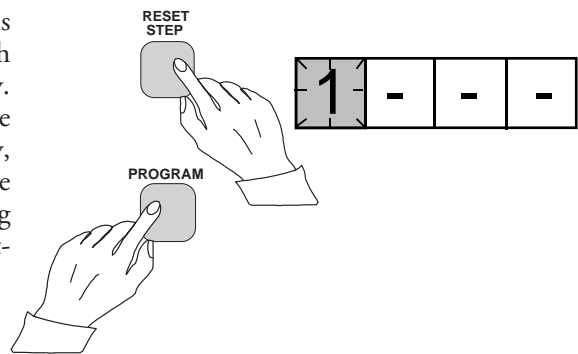

l)
Recording the new value automatically initiates a return from the setting mode to the normal menu. Without recording one can leave the setting mode any time by pressing the PROGRAM push button for about five seconds, until the green display digits stop flashing.

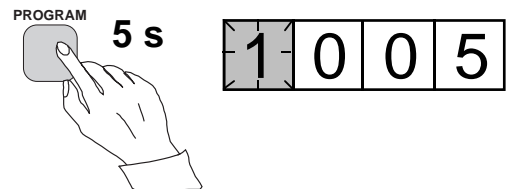

m)
After recording the desired values return to the main menu is obtained by pressing the STEP push button until the first digit is turned off. The LED indicator SGF still shows that one is in the SGF position and that the display shows the new checksum for SGF1 currently in use by the relay module.

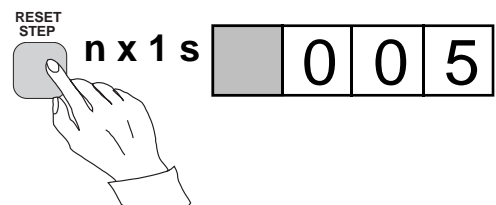

Recorded information

The parameter values measured at the moment when a fault occurs or at the trip instant are recorded in the registers. The recorded data, except for some parameters, are set to zero by pressing the push buttons STEP and PROGRAM simultaneously. The data in normal registers are erased if the auxiliary voltage supply to the relay is interrupted, only the set values and certain other essential parameters are maintained in non-volatile registers during a voltage failure.

The number of registers varies with different relay module types. The functions of the registers are illustrated in the descriptions of the different relay modules. Additionally, the system front panel of the relay contains a simplified list of the data recorded by the various relay modules of the protection relay.

All D type relay modules are provided with two general registers: register 0 and register A.

Register 0 contains, in coded form, the information about e.g. external blocking signals, status information and other signals. The codes are explained in the manuals of the different relay modules.

Register A contains the address code of the relay modul which is required by the serial communication system.

Submenu 1 of register A contains the data transfer rate value, expressed in kilobaud, of the serial communication.

Submenu 2 of register A contains a bus communication monitor for the SPAbus. If the protection relay, which contains the relay module, is linked to a system including a control data communicatoe, for instance SRIO 1000M and the data communication system is operating, the counter reading of the monitor will be zero. Otherwise the digits 1...255 are continuously scrolling in the monitor.

Submenu 3 contains the password required for changing the remote settings. The address code, the data transfer rate of the serial communication and the password can be set manually or via the serial communication bus. For manual setting see example 1.

The default value is 001 for the address code, 9.6 kilobaud for the data transfer rate and 001 for the password.

In order to secure the setting values, all settings are recorded in two separate memory banks within the non-volatile memory. Each bank is complete with its own checksum test to verify the condition of the memory contents. If, for some reason, the contents of one bank is disturbed, all settings are taken from the other bank and the contents from here is transferred to the faulty memory region, all while the relay is in full operation condition. If both memory banks are simultaneously damaged the relay will be set out of operation, and an alarm signal will be given over the serial port and the IRF output relay

Trip test function

Register 0 also provides access to a trip test function, which allows the output signals of the relay module to be activated one by one. If the auxiliary relay module of the protection assembly is in place, the auxiliary relays then will operate one by one during the testing.

When pressing the PROGRAM push button for about five seconds, the green digits to the right start flashing indicating that the relay module is in the test position. The indicators of the settings indicate by flashing which output signal can be activated. The required output function is selected by pressing the PROGRAM push button for about one second.

The indicators of the setting quantities refer to the following output signals:

Setting I>	Starting of stage I>
Setting t>	Tripping of stage I>
Setting I>>	Starting of stage I>>
Setting t>>	Tripping of stage I>>
etc.	
No indication	Self-supervision IRF

The selected starting or tripping is activated by simultaneous pressing of the push buttons STEP and PROGRAM. The signal remains activated as long as the two push buttons are pressed. The effect on the output relays depends on the configuration of the output relay matrix switches.

The self-supervision output is activated by pressing the STEP push button 1 second when no setting indicator is flashing. The IRF output is activated in about 1 second after pressing of the STEP push button.

The signals are selected in the order illustrated in Fig. 4.

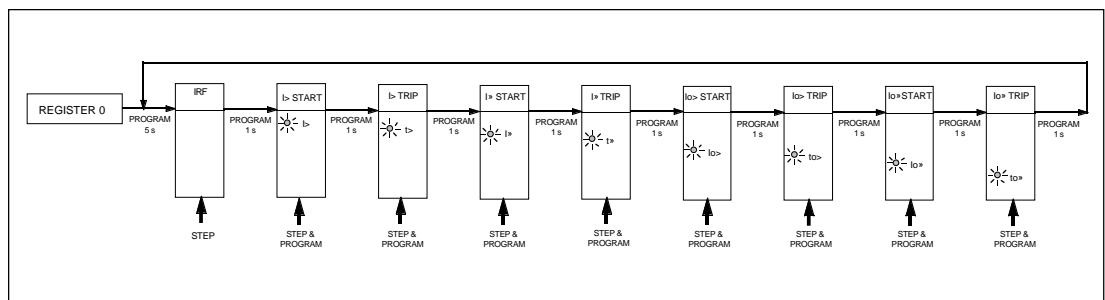

Fig. 5. Sequence order for the selection of output signals in the Trip test mode

If, for instance, the indicator of the setting t> is flashing, and the push buttons STEP and PROGRAM are being pressed, the trip signal from the low-set overcurrent stage is activated. Return to the main menu is possible at any stage of the trip test sequence scheme, by pressing the PROGRAM push button for about five seconds.

Note!

The effect on the output relays then depends on the configuration of the output relay matrix switchgroups SGR 1...3.

Example 3

Trip test function. Forced activation of the outputs.

- a)
Step forward on the display to register 0.

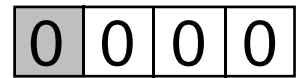
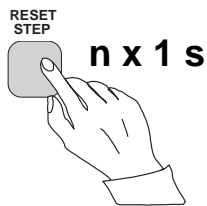

- b)
Press the PROGRAM push button for about five seconds until the three green digits to the right.

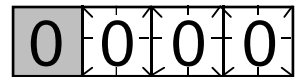
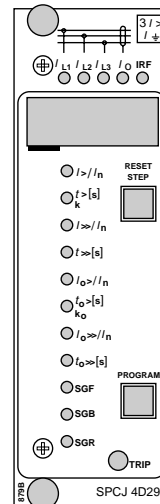

- c)
Hold down the STEP push button. After one second the red IRF indicator is lit and the IRF output is activated. When the step push button is released the IRF indicator is switched off and the IRF output resets.

- d)
Press the PROGRAM push button for one second and the indicator of the topmost setting start flashing.

- e)
If a start of the first stage is required, now press the push-buttons PROGRAM and STEP simultaneously. The stage output will be activated and the output relays will operate according to the actual programming of the relay output switchgroups SGR.

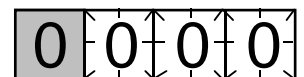
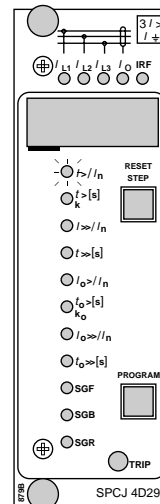
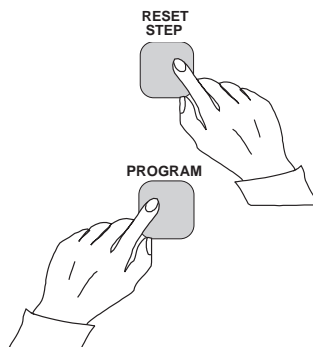

f)
To proceed to the next position press the PROGRAM push button for about 1 second until the indicator of the second setting starts flashing.

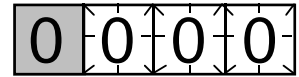
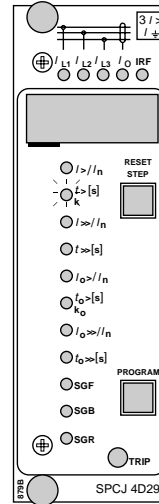
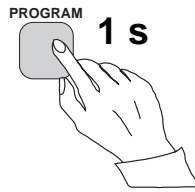

g)
Press the push buttons PROGRAM and STEP simultaneously to activate tripping of stage 1 (e.g. the I> stage of the overcurrent module SPCJ 4D29). The output relays will operate according to the actual programming of the relay switchgroups SGR. If the main trip relay is operated the trip indicator of the measuring module is lit.

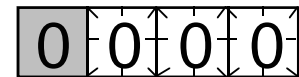
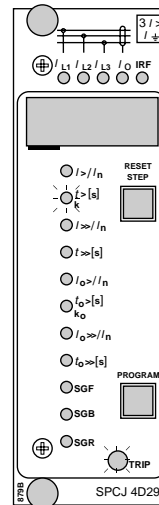
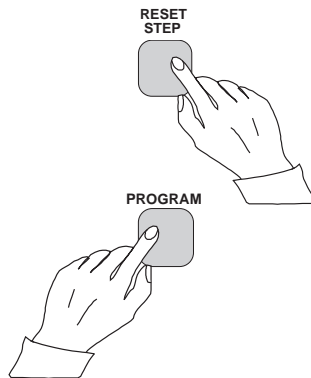

h)
The starting and tripping of the remaining stages are activated in the same way as the first stage above. The indicator of the corresponding setting starts flashing to indicate that the concerned stage can be activated by pressing the STEP and PROGRAM buttons simultaneously. For any forced stage operation, the output relays will respond according to the setting of the relay output switchgroups SGR. Any time a certain stage is selected that is not wanted to operate, pressing the PROGRAM button once more will pass by this position and move to the next one without carrying out any operation of the selected stage.

It is possible to leave the trip test mode at any step of the sequence scheme by pressing the PROGRAM push button for about five seconds until the three digits to the right stop flashing.

Operation indication

A relay module is provided with a multiple of separate operation stages, each with its own operation indicator shown on the display and a common trip indicator on the lower part of the front plate of the relay module.

The starting of a relay stage is indicated with one number which changes to another number when the stage operates. The indicator remains glowing although the operation stage resets. The

indicator is reset by means of the RESET push button of the relay module. An unreset operation indicator does not affect the function of the protection relay module.

In certain cases the function of the operation indicators may deviate from the above principles. This is described in detail in the descriptions of the separate modules.

Fault codes

In addition to the protection functions the relay module is provided with a self-supervision system which continuously supervises the function of the microprocessor, its program execution and the electronics.

Shortly after the self-supervision system detects a permanent fault in the relay module, the red IRF indicator on the front panel is lit. At the same time the module puts forward a control signal to the output relay of the self-supervision system of the protection relay.

In most fault situations a fault code, indicating the nature of the fault, appears on the display of

the module. The fault code, which consists of a red figure "1" and a three digit green code number, cannot be removed from the display by resetting. When a fault occurs, the fault code should be recorded and stated when service is ordered. When in a fault mode, the normal relay menus are operative, i.e. all setting values and measured values can be accessed although the relay operation is inhibited. The serial communication is also operative making it possible to access the relay information also from a remote site. The internal relay fault code shown on the display remains active until the internal fault possibly disappears and can also be remotely read out as variable V 169.

SPCJ 4D29

Overcurrent and earth-fault relay module

User's manual and Technical description

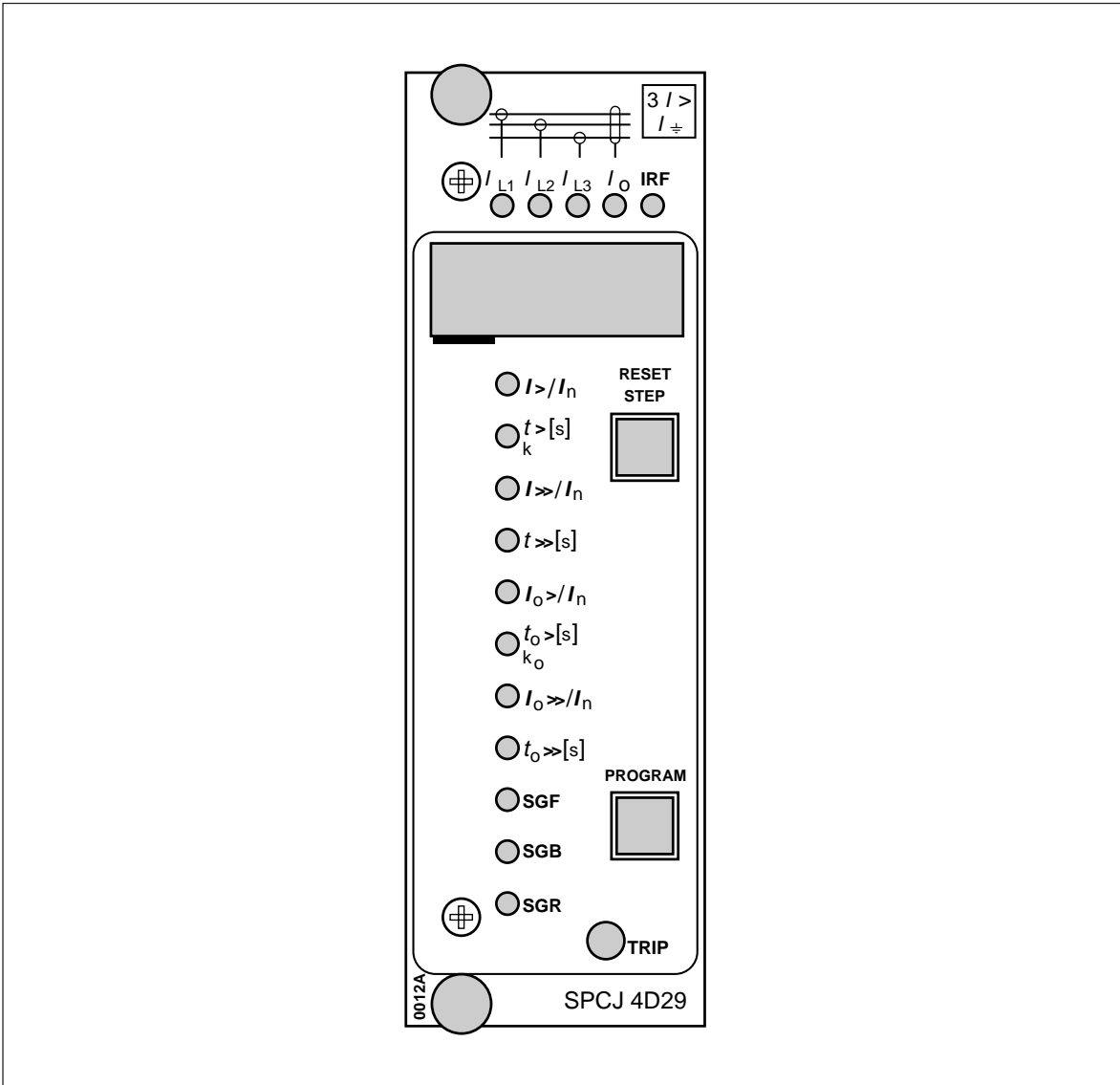

SPCJ 4D29

Combined overcurrent and earth-fault relay module

Data subject to change without notice

Contents	Features	2
	Description of function	3
	Block diagram	5
	Front panel	6
	Start and operation indicators	7
	Settings	8
	Selector switches	9
	Measured data	13
	Recorded information	14
	Menu and register chart	16
	Time/current characteristic (<i>modified 2002-05</i>)	18
	Technical data	26
	Serial communication parameters	27
	Fault codes	34

Features	Low-set phase overcurrent stage $I_{>}$ with definite time or inverse time characteristic	Six time/current curve sets at inverse time characteristic of the overcurrent stage $I_{>}$ and the earth-fault stage $I_{0>}$
	High-set phase overcurrent stage $I_{>>}$ with instantaneous function or definite time characteristic	Digital display of measured and set values and data sets recorded at the moment of relay operation
	Low-set earth-fault stage $I_{0>}$ with definite time or inverse time characteristic	Parametrization of the module by push-buttons on the front panel or via the serial port using a portable PC and a suitable software
	High-set earth-fault stage $I_{0>>}$ with definite time characteristic	Continuous hardware and software supervision including auto-diagnosis

Description of function

Phase overcurrent unit

The phase overcurrent unit of the relay module SPCJ 4D29 is designed for single-phase, two-phase or three-phase overcurrent protection. It includes two overcurrent stages, i.e. a low-set overcurrent stage $I_{>}$ and a high-set overcurrent stage $I_{>>}$.

The low-set or high-set phase overcurrent stage starts if the current on one or several of the phases exceeds the set start current value of the stage concerned. When the stage starts it generates a start signal SS1 or TS1 and simultaneously the digital display on the front panel indicates starting. If the overcurrent situation lasts long enough to exceed the set operate time, the stage operates and generates a trip signal TS2. At the same time the operation indicator is lit with red light. The red operation indicator remains lit although the stage resets. The indicator is reset by pushing the RESET push-button. By proper configuration of the output relay switchgroups an additional auxiliary trip signal TS1 can be obtained.

The operation of the low-set phase overcurrent stage $I_{>}$ or the high-set phase overcurrent stage $I_{>>}$ can be blocked by routing a blocking signal BS to the unit. The blocking configuration is set with switchgroup SGB.

The operation of the low-set phase overcurrent stage can be based on definite time or inverse time characteristic. The operation characteristic is selected with the SGF1/1...3 switches. At definite time operation characteristic the operate time $t_{>}$ is set in seconds within the range, 0.05...300 s. When the inverse time operation characteristic (IDMT) is selected, four internationally standardized and two complementary time/current curves are available. The selector switches SGF1/1...3 are also used for selecting the desired operation characteristic.

Note!

The maximum continuous current carrying capacity of the energizing inputs is $4 \times I_n$, which must be observed when relay settings are calculated.

Note!

At inverse time characteristic the effective setting range of the low-set overcurrent stage is $0.5 \dots 2.5 \times I_n$, although start current settings within the range $2.5 \dots 5.0 \times I_n$ can be set on the relay. At inverse time characteristic any start current setting above $2.5 \times I_n$ of the low-set stage will be regarded as being equal to $2.5 \times I_n$.

Note!

The operation of the low-set stage based on inverse time characteristic will be blocked by starting of the high-set stage. Then the operate time of the overcurrent unit is determined by the set operate time of the high-set stage at heavy fault currents.

The setting range of the operate time $t_{>>}$ of the high-set phase overcurrent stage is 0.04...300 s.

The operate signal of the two overcurrent stages is provided with a latching feature (switch SGB/6) which means that the operate signal TS2 is kept high after an operation, although the overcurrent stage resets. The latched TS2 signal is reset by pushing the RESET and PROGRAM push-buttons simultaneously or via the serial port using the command V101, see also chapter "Selector switches".

The set start current value $I_{>>}$ of the high-set phase overcurrent stage can be doubled automatically on connection of the protected object to the network, i.e. at starting. In this way the start current of the high-set phase overcurrent stage can be given a lower value than the level of the connection inrush current. The automatic doubling function is selected with switch SGF1/5. The starting, which activates the doubling function, is defined as a situation where the phase currents rise from a value below $0.12 \times I_{>}$ to a value exceeding $1.5 \times I_{>}$ in less than 60 ms. The function stops when the currents fall below $1.25 \times I_{>}$.

The setting range of the start current of the high-set phase overcurrent stage is $0.5 \dots 40 \times I_n$. When the high-set stage is given a start current setting in the lower end of the setting range, the relay module will contain two almost identical overcurrent stages. This enables the overcurrent unit of the SPCJ 4D29 module to be used, for example, in two-stage load shedding applications.

The high-set phase overcurrent stage can be set out of operation with switch SGF2/5. When the high-set stage is set out of operation the display shows "- - -", indicating that the start current setting is infinite.

Earth-fault unit	<p>The non-directional earth-fault unit of the relay module SPCJ 4D29 is a single-pole earth-fault unit. It contains two earth-fault stages, i.e. a low-set earth-fault stage $I_{0>}$ and a high-set earth-fault stage $I_{0>>}$.</p> <p>The low-set or high-set earth-fault stage starts, if the measured current exceeds the set start current value. When the stage starts it generates a start signal SS1 or TS1 and simultaneously the digital display on the front panel indicates starting. If the earth-fault situation lasts long enough to exceed the set operate time, the stage operates and generates a trip signal TS2. At the same time the operation indicator TRIP is lit with red light. The red operation indicator remains lit although the stage resets. The indicator is reset by pushing the RESET push-button. By proper configuration of the output relay switchgroups an additional auxiliary trip signal TS1 can be obtained.</p> <p>The operation of the low-set earth-fault stage $I_{0>}$ or the high-set earth-fault stage $I_{0>>}$ can be blocked by routing a blocking signal BS to the earth-fault unit. The blocking configuration is set with switchgroup SGB.</p> <p>The operation of the low-set earth-fault stage can be based on definite time or inverse time characteristic. The operation characteristic is selected with the SGF/6...8 switches. At definite time operation characteristic the operate time $t_{0>}$ is directly set in seconds within the</p>	<p>range, 0.05...300 s. When the inverse time operation characteristic (IDMT) is selected, four internationally standardized and two complementary time/current curves are available. The selector switches SGF1/ 6...8 are also used for selecting the desired operation characteristic.</p> <p>The setting range of the operate time $t_{0>>}$ of the high-set earth-fault stage is 0.05...300 s.</p> <p>Note! The operation of the low-set stage based on inverse time characteristic will be blocked by starting of the high-set stage. Then the operate time of the earth-fault unit is determined by the set operate time of the high-set stage at heavy fault currents.</p> <p>The operate signal of the two earth-fault stages is provided with a latching feature (switch SGB/7) which means that the operate signal TS2 is kept high after an operation, although the earth-fault stage resets. The TS2 signal is reset by pushing the RESET and PROGRAM push-buttons simultaneously or via the serial port using the command V101, see chapter "Selector switches", page 9.</p> <p>The high-set earth-fault stage can be set out of operation with switch SGF2/6. When the high-set stage is set out of operation the display shows " - - - ", indicating that the start current setting is infinite.</p>
Circuit breaker failure protection unit	<p>The relay module features a circuit breaker failure protection (CBFP) unit. The CBFP unit generates a trip signal via TS1 after a set operate time 0.1...1 s, following the main trip signal TS2, if the fault has not been cleared before the set operate time has elapsed. The output contact of the CBFP unit is normally used for tripping</p>	<p>an upstream circuit breaker. The CBFP unit can also be used for tripping via redundant trip circuits of the same circuit breaker, if the circuit breaker is provided with two trip coils. The circuit breaker failure protection unit is alerted/ set out of operation with switch SGF1/4.</p>
Remote setting	<p>The relay can be given two sets of setting values, the main settings and the second settings. Switching between main settings and second settings can be done in three different ways, i) with a</p>	<p>command V150 via the serial port, ii) with a command via the external control input BS or manually by changing a parameter in submenu 4 of register A.</p>

Block diagram

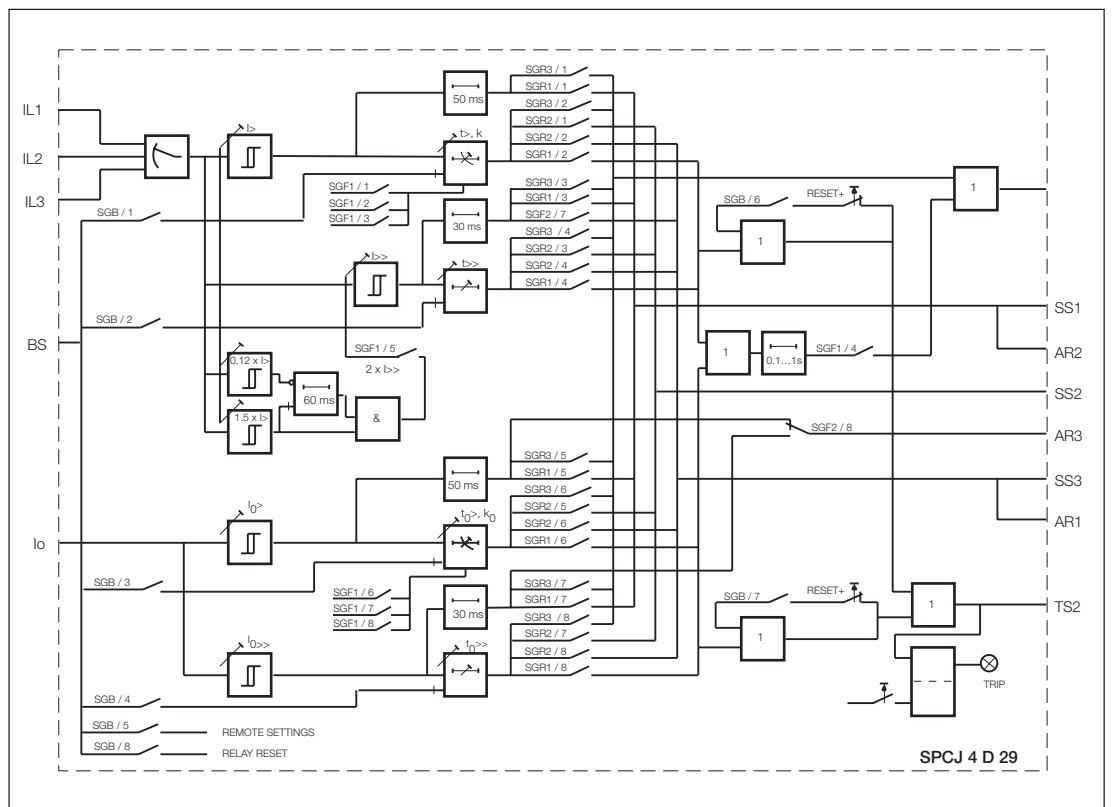

Fig. 1. Block diagram for the combined overcurrent and earth-fault relay module SPCJ 4D29.

I_{L1}, I_{L2}, I_{L3}	Energizing currents
I_0	Residual current
BS	External control signal
SGF1...2	Selector switchgroup SGF for operational relay functions
SGB	Selector switchgroup SGB for special relay functions
SGR1...3	Selector switchgroups SGR for configuration of output relays
TS1	Start signal 1 or auxiliary trip signal configured with switchgroup SGR3
SS1	Start signal configured with switchgroup SGR1
SS2	Trip signal 1 configured with switchgroup SGR2
SS3	Trip signal 2 configured with switchgroup SGR2
TS2	Trip signal configured with switchgroup SGR1
AR1, AR2, AR3	Start signals to possible external optional auto-reclose relays
TRIP	Red operation (trip) indicator

Note!

All input and output signals of the relay module are not necessarily wired to the terminals of a particular relay. The signals wired to the termi-

nals of a particular protection relay are shown in the signal diagram in the general part of the relay manual.

Front panel

Indicators for the measured phase currents I_{L1} , I_{L2} , I_{L3} and the residual current I_0

Indicator for the start current of the $I>$ stage
 Indicator for the operate time $t>$ or time multiplier k of the $I>$ stage

Indicator for the start current of the $I>>$ stage
 Indicator for the operate time of the $I>>$ stage

Indicator for the start current of the $I_0>$ stage
 Indicator for the operate time $t_0>$ or time multiplier k_0 of the $I_0>$ stage

Indicator for the start current of the $I_0>>$ stage
 Indicator for the operate time of the $I_0>>$ stage

Indicator for the checksum of switchgroups SGF1...2

Indicator for the checksum of switchgroup SGB

Indicator for the checksum of switchgroups SGR1...3

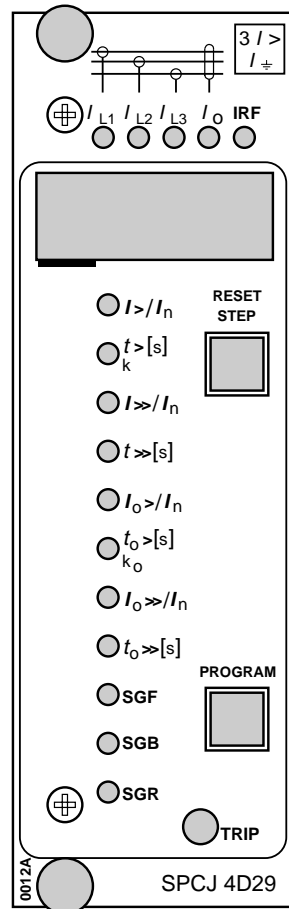
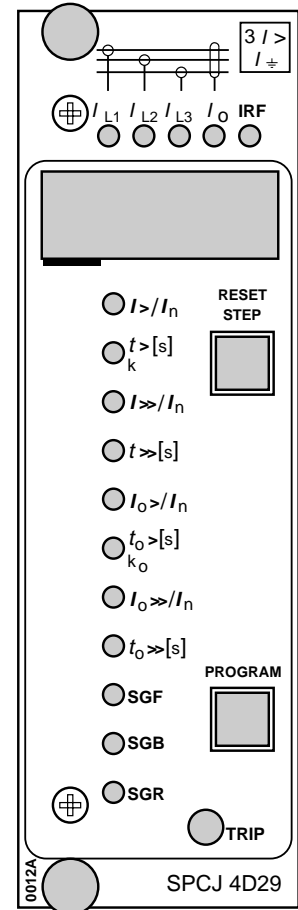

Relay module symbol

Self-supervision alarm indicator

Digital display

Reset and display step push-button

Selector push-button

TRIP indicator

Type designation of the module

Fig. 2. Front panel of the combined overcurrent and earth-fault relay module SPCJ 4D29.

Start and operation indicators

Both overcurrent stages have their own start indicators and operation indicators shown as figures on the digital display. Further, all the protection stages share a common red LED indicator marked "TRIP" which is located in the lower right corner of the front panel and which is lit on operation of a stage.

The figure on the display indicating starting or operation remains lit when the current stage resets, thus indicating which protection stage

has operated. The start or operation indicators are reset by pushing the RESET push-button. The function of the relay module is not affected by an unreset indicator. If the starting of a stage is short enough not to cause an operation of the relay, the start indication is normally self-reset when the stage resets. By means of switches SGF2/1...4 the start indicators can be configured for manual resetting. The following table shows a guide to the start and trip indicators of the relay module.

Indication	Explanation
1	I> START = the low-set stage I> of the overcurrent unit has started
2	I> TRIP = the low-set stage I> of the overcurrent unit has operated
3	I>> START = the high-set stage I>> of the overcurrent unit has started
4	I>> TRIP = the high-set stage I>> of the overcurrent unit has operated
5	I ₀ > START = the low-set stage I ₀ > of the earth-fault unit has started
6	I ₀ > TRIP = the low-set stage I ₀ > of the earth-fault unit has operated
7	I ₀ >> START = the high-set stage I ₀ >> of the earth-fault unit has started
8	I ₀ >> TRIP = the high-set stage I ₀ >> of the earth-fault unit has operated
9	CBFP = the circuit breaker failure protection has operated

When one of the protection stages of the relay module operates, the indicators for the energizing current of the module show the faulty phase, i.e. in which phase(s) the current has exceeded the set start value of the stage (so called phase fault indication). If, for instance, the operation indicator "2" of the low-set stage is lit, as are the indicators I_{L1} and I_{L2} also, the relay operation has been caused by overcurrent on the L1 and L2 phases. The fault indications are reset by pushing the RESET push-button.

The self-supervision alarm indicator IRF indicates, when lit, that the self-supervision system has detected a permanent internal relay fault. The indicator is lit with red light shortly after a fault has been detected. At the same time the relay module generates a control signal to the output relay of the self-supervision system IRF. Additionally, in most fault cases, an auto-diagnostic fault code showing the nature of the fault appears on the display. The fault code, consists of a red figure one (1) and a green code number. When a fault code is obtained it should be recorded for statistical and maintenance purposes.

Settings

The setting values are shown by the right-most three digits of the display. When lit, the LED indicators on the front panel adjacent to the symbol of the setting quantity shows the quantity currently being displayed.

$I_{>}/I_n$	Start current of the $I_{>}$ stage as a multiple of the rated current of the used energizing input. Setting range $0.5 \dots 5.0 \times I_n$ at definite time characteristic and $0.5 \dots 2.5 \times I_n$ at inverse time characteristic. Note! At inverse time characteristic any setting above $2.5 \times I_n$ will be regarded as being equal to $2.5 \times I_n$.
$t_{>}$	Operate time of the $I_{>}$ stage expressed in seconds, at definite time characteristic (SGF1/1-2-3 = 0-0-0). Setting range 0.05...300 s.
k	Time multiplier of the $I_{>}$ stage at inverse time characteristic. Setting range 0.05...1.00.
$I_{>>}/I_n$	Start current of the $I_{>>}$ stage as a multiple of the rated current of the used energizing input. Setting range $0.5 \dots 40.0 \times I_n$. Additionally the setting "infinite" (displayed as n - - -) can be selected with switch SGF2/5, which means that the high-set stage $I_{>>}$ is out of operation.
$t_{>>}$	Operate time of the $I_{>>}$ stage expressed in seconds. Setting range 0.04...300 s.
$I_{0>}/I_n$	Start current of the $I_{0>}$ stage as a multiple of the rated current of the used energizing input. Setting range $0.1 \dots 0.8 \times I_n$.
$t_{0>}$	Operate time of the $I_{0>}$ stage, expressed in seconds, at definite time characteristic (SGF1/6-7-8 = 0-0-0). Setting range 0.05...300 s.
k_0	Time multiplier k_0 of the $I_{0>}$ stage at inverse time characteristic. Setting range 0.05...1.00.
$I_{0>>}/I_n$	Start current of the $I_{0>>}$ stage as a multiple of the rated current of the used energizing input. Setting range $0.1 \dots 10.0 \times I_n$. Additionally the setting "infinite" (displayed as n - - -) can be selected with switch SGF2/6, which means that the earth-fault stage $I_{0>>}$ is out of operation.
$t_{0>>}$	Operate time of the $I_{0>>}$ stage expressed in seconds. Setting range 0.05...300 s.

Further, the checksums of switchgroups SGF1, SGB and SGR1 are shown on the display when the indicators adjacent to the switchgroup symbols on the front panel are lit. The checksums for switchgroups SGF2, SGR2 and SGR3 are found in the submenus under the main menu of

the first switchgroup. For further information, see chapter "Menus and registers". An example of how the checksum can be calculated manually is given in manual "General characteristics of D type relay modules..

Selector switches

Additional functions required in various applications are selected with switchgroups SGF, SGB and SGR indicated on the front panel. The numbering of the switches, 1...8, and the switch positions 0 and 1 are shown when the switch-

groups are set. Under normal service conditions only the checksums are shown. Switchgroups SGF2, SGR2 and SGR3 are found in the sub-menus of the main menus of switchgroups SGF and SGR.

Function switch-group SGF1

Switch	Function																																													
SGF1/1 SGF1/2 SGF1/3	<p>Switches SGF1/1...3 are used for selecting the characteristic of the low-set overcurrent stage I>, i.e. definite time operation characteristic or inverse definite minimum time (IDMT) characteristic. At IDMT characteristic the switches are also used for selecting the required current/time characteristic for the stage.</p> <table border="1"> <thead> <tr> <th>SGF1/1</th> <th>SGF1/2</th> <th>SGF1/3</th> <th>Characteristic</th> <th>Time or curve set</th> </tr> </thead> <tbody> <tr> <td>0</td> <td>0</td> <td>0</td> <td>Definite time</td> <td>0.05...300 s</td> </tr> <tr> <td>1</td> <td>0</td> <td>0</td> <td>IDMT</td> <td>Extremely inverse</td> </tr> <tr> <td>0</td> <td>1</td> <td>0</td> <td>IDMT</td> <td>Very inverse</td> </tr> <tr> <td>1</td> <td>1</td> <td>0</td> <td>IDMT</td> <td>Normal inverse</td> </tr> <tr> <td>0</td> <td>0</td> <td>1</td> <td>IDMT</td> <td>Long-time inverse</td> </tr> <tr> <td>1</td> <td>0</td> <td>1</td> <td>IDMT</td> <td>RI-characteristic</td> </tr> <tr> <td>0</td> <td>1</td> <td>1</td> <td>IDMT</td> <td>RXIDG-characteristic</td> </tr> <tr> <td>1</td> <td>1</td> <td>1</td> <td>---</td> <td>(Long-time inverse)</td> </tr> </tbody> </table>	SGF1/1	SGF1/2	SGF1/3	Characteristic	Time or curve set	0	0	0	Definite time	0.05...300 s	1	0	0	IDMT	Extremely inverse	0	1	0	IDMT	Very inverse	1	1	0	IDMT	Normal inverse	0	0	1	IDMT	Long-time inverse	1	0	1	IDMT	RI-characteristic	0	1	1	IDMT	RXIDG-characteristic	1	1	1	---	(Long-time inverse)
SGF1/1	SGF1/2	SGF1/3	Characteristic	Time or curve set																																										
0	0	0	Definite time	0.05...300 s																																										
1	0	0	IDMT	Extremely inverse																																										
0	1	0	IDMT	Very inverse																																										
1	1	0	IDMT	Normal inverse																																										
0	0	1	IDMT	Long-time inverse																																										
1	0	1	IDMT	RI-characteristic																																										
0	1	1	IDMT	RXIDG-characteristic																																										
1	1	1	---	(Long-time inverse)																																										
SGF1/4	<p>Circuit breaker failure protection (CBFP).</p> <p>When SGF1/4 = 1 the trip signal TS2 will start a timer which will generate a delayed operate signal via TS1, if the fault has not been cleared before the operate time has elapsed.</p> <p>When switch SGF1/4 = 0 the circuit breaker failure protection is out of operation.</p>																																													
SGF1/5	<p>Automatic doubling of the set start current of the high-set overcurrent stage I>> when the protected object is energized.</p> <p>When SGF1/5 = 0, no doubling of the start current setting of stage I>> is obtained. When SGF1/5 = 1, the start current setting of stage I>> doubles automatically. The doubling feature makes it possible to give the high-set stage a setting value below the connection inrush current level.</p>																																													
SGF1/6 SGF1/7 SGF1/8	<p>Switches SGF1/6...8 are used for selecting the operation characteristic of the low-set earth-fault stage I₀>, i.e. definite time characteristic or inverse definite minimum time (IDMT) characteristic. At inverse definite minimum time characteristic the switches are also used for selecting the current/time characteristic of the stage.</p> <table border="1"> <thead> <tr> <th>SGF1/6</th> <th>SGF1/7</th> <th>SGF1/8</th> <th>Characteristic</th> <th>Time or curve</th> </tr> </thead> <tbody> <tr> <td>0</td> <td>0</td> <td>0</td> <td>Definite time</td> <td>0.05...300 s</td> </tr> <tr> <td>1</td> <td>0</td> <td>0</td> <td>IDMT</td> <td>Extremely inverse</td> </tr> <tr> <td>0</td> <td>1</td> <td>0</td> <td>IDMT</td> <td>Very inverse</td> </tr> <tr> <td>1</td> <td>1</td> <td>0</td> <td>IDMT</td> <td>Normal inverse</td> </tr> <tr> <td>0</td> <td>0</td> <td>1</td> <td>IDMT</td> <td>Long-time inverse</td> </tr> <tr> <td>1</td> <td>0</td> <td>1</td> <td>IDMT</td> <td>RI-characteristic</td> </tr> <tr> <td>0</td> <td>1</td> <td>1</td> <td>IDMT</td> <td>RXIDG-characteristic</td> </tr> <tr> <td>1</td> <td>1</td> <td>1</td> <td>IDMT</td> <td>Not in use (long-time inverse)</td> </tr> </tbody> </table>	SGF1/6	SGF1/7	SGF1/8	Characteristic	Time or curve	0	0	0	Definite time	0.05...300 s	1	0	0	IDMT	Extremely inverse	0	1	0	IDMT	Very inverse	1	1	0	IDMT	Normal inverse	0	0	1	IDMT	Long-time inverse	1	0	1	IDMT	RI-characteristic	0	1	1	IDMT	RXIDG-characteristic	1	1	1	IDMT	Not in use (long-time inverse)
SGF1/6	SGF1/7	SGF1/8	Characteristic	Time or curve																																										
0	0	0	Definite time	0.05...300 s																																										
1	0	0	IDMT	Extremely inverse																																										
0	1	0	IDMT	Very inverse																																										
1	1	0	IDMT	Normal inverse																																										
0	0	1	IDMT	Long-time inverse																																										
1	0	1	IDMT	RI-characteristic																																										
0	1	1	IDMT	RXIDG-characteristic																																										
1	1	1	IDMT	Not in use (long-time inverse)																																										

On delivery from the factory all switches SGF1 are set at zero, i.e. the checksum for SGF1 is 0.

Function switch-
group SGF2

Switch	Function
SGF2/1 SGF2/2 SGF2/3 SGF2/4	<p>Switches SGF2/1...4 are used for selecting the operation characteristic of the start indicators of the different stages. When the switches are in position 0 the start signals are all automatically reset when the fault is cleared. To give the indicator of a stage the hand reset mode of operation, the corresponding switch is set in position 1:</p> <p>SGF2/1 = 1 equals manual reset mode for the start indication of stage I> SGF2/2 = 1 equals manual reset mode for the start indication of stage I>> SGF2/3 = 1 equals manual reset mode for the start indication of stage I₀> SGF2/4 = 1 equals manual reset mode for the start indication of stage I₀>></p>
SGF2/5	<p>Operation of the high-set phase overcurrent stage I>>.</p> <p>When SGF2/5 = 0 the high-set stage I>> is alerted When SGF2/5 = 1 the high-set stage I>> is out of operation and the display shows " _ _ _ "</p>
SGF2/6	<p>Operation of the high-set earth-fault stage I₀>>.</p> <p>When SGF2/6 = 0 the high-set stage I₀>> is alerted When SGF2/6 = 1 the high-set stage I₀>> is out of operation and the display shows " _ _ _ "</p>
SGF2/7	<p>Start signal of the high-set stage I>> to the auto-reclose signal output AR1.</p> <p>When SGF2/7 = 1, the start signal of the I>> stage is routed to output AR1.</p> <p>Note! Outputs AR1 and SS3 are interconnected and they always carry the same signal. Therefore, if AR1 is used for starting auto-reclose functions, SS3 cannot be used for any other purpose.</p> <p>When SGF2/7 = 0, the start signal of the I>> stage is not routed to output AR1 nor SS3. Thus the signal output SS3 is available for other purposes.</p>
SGF2/8	<p>Start signal of the low-set stage I₀> or high-set stage I₀>> to auto-reclose signal output AR3.</p> <p>When SGF2/8 = 0 the start signal from the I₀> stage is routed to output AR3 When SGF2/8 = 1 the start signal from the I₀>> stage is routed to output AR3</p>

When the relay is delivered from the factory the SGF2 switches are set at zero, i.e. the checksum for SGF2 is 0.

Blocking or control signal configuration switchgroup SGB

Switch	Function
SGB/1 SGB/2 SGB/3 SGB/4	<p>Switches SGB/1...4 are used for routing an external blocking signal BS to one or more of the protection stages of the relay module. When the switches all are in position 0 no stage is blocked.</p> <p>When SGB/1 = 1 the I> stage is blocked by the external control signal BS When SGB/2 = 1 the I>> stage is blocked by the external control signal BS When SGB/3 = 1 the I₀> stage is blocked by the external control signal BS When SGB/4 = 1 the I₀>> stage is blocked by the external control signal BS</p>
SGB/5	<p>Selection of main settings or second settings with an external control signal BS or via the serial interface using command V150.</p> <p>When SGB/5 = 0 the settings can be controlled via the serial port but not via the external control input BS When SGB/5 = 1, the settings can be controlled via the external control input. The main values are enforced when the control input is not energized and the second settings are enforced when the control input is energized.</p> <p>Note! When the application includes switching between main and second settings, it should be noted that switch SGB/5 must have the same position in the main set of settings and the second set of settings. Otherwise a conflict situation might occur when the settings are switched by external control or via the serial port.</p>
SGB/6	<p>Latching of the trip signal TS2 of the phase overcurrent unit.</p> <p>When SGB/6 = 0 the trip signal returns to its initial state (= the output relay drops off), when the energizing signal causing the operation falls below the set start current. When SGB/6 = 1 the trip signal is latched (= the output relay remains picked up after operation), although the energizing signal falls below the start current. The trip signal is to be manually reset by pushing the push-buttons RESET and PROGRAM simultaneously. ¹⁾</p>
SGB/7	<p>Latching of the trip signal TS2 of the earth-fault unit.</p> <p>When SGB/7 = 0 the trip signal returns to its initial state (= the output relay drops off), when the measuring signal causing the operation falls below the set start current. When SGB/7 = 1 the trip signal is latched (= the output relay remains picked up after operation), although the energizing signal falls below the start current. The trip signal is to be manually reset by pushing the push-buttons RESET and PROGRAM simultaneously. ¹⁾</p>
SGB/8	<p>Remote resetting of a latched output relay and memorized values.</p> <p>When the output TS2 has been given the latching mode with switch SGB/6 or SGB/7, a remote reset can be performed using the external control input BS, when switch SGB/8 =1.</p>

When the relay is delivered from the factory the SGB switches are set at zero, i.e. the checksum for SGB is 0.

¹⁾ From the program versions 037F or 056A and later versions an additional feature has been incorporated into the relay module SPCJ 4D29. When the latching function is used the latched output can be reset by pushing the PROGRAM button alone, in which case the stored information of the module is not erased.

Output relay matrix
switchgroups SGR1,
SGR2 and SGR3

SGR1	The switches of switchgroup SGR1 are used to select the start and operate signals to be routed to outputs SS1 and TS2.
SGR2	The switches of switchgroup SGR2 are used for routing the operate signals of the protection stages to the outputs SS2 and SS3.
SGR3	The switches of switchgroup SGR3 are used to route the start and operate signals to the start or auxiliary trip output TS1. Note! If the circuit breaker failure protection has been taken in use with switch SGF1/4, it will also occupy the TS1 output.

Switch number	Function	Factory setting	Checksum value
SGR1/1	When SGR1/1 = 1, the start signal of the I> stage is routed to SS1	1	1
SGR1/2	When SGR1/2 = 1, the operate signal of the I> stage is routed to TS2	1	2
SGR1/3	When SGR1/3 = 1, the start signal of the I>> stage is routed to SS1	0	4
SGR1/4	When SGR1/4 = 1, the operate signal of the I>> stage is routed to TS2	1	8
SGR1/5	When SGR1/5 = 1, the start signal of the I ₀ > stage is routed to SS1	0	16
SGR1/6	When SGR1/6 = 1, the operate signal of the I ₀ > stage is routed to TS2	1	32
SGR1/7	When SGR1/7 = 1, the starting signal of the I ₀ >> stage is routed to SS1	0	64
SGR1/8	When SGR1/8 = 1, the operate signal of the I ₀ >> stage is routed to TS2	1	128
Checksum for the factory settings of switchgroup SGR1			171

SGR2/1	When SGR2/1 = 1, the operate signal of the I> stage is routed to SS2	1	1
SGR2/2	When SGR2/2 = 1, the operate signal of the I> stage is routed to SS3	0	2
SGR2/3	When SGR2/3 = 1, the operate signal of the I>> stage is routed to SS2	1	4
SGR2/4	When SGR2/4 = 1, the operate signal of the I>> stage is routed to SS3	0	8
SGR2/5	When SGR2/5 = 1, the operate signal of the I ₀ > stage is routed to SS2	0	16
SGR2/6	When SGR2/6 = 1, the operate signal of the I ₀ > stage is routed to SS3	1	32
SGR2/7	When SGR2/7 = 1, the operate signal of the I ₀ >> stage is routed to SS2	0	64
SGR2/8	When SGR2/8 = 1, the operate signal of the I ₀ >> stage is routed to SS3	1	128
Checksum for the factory settings of switchgroup SGR2			165

Switch number	Function	Factory setting	Checksum value
SGR3/1	When SGR3/1 = 1, the start signal of the I> stage is routed to TS1	0	1
SGR3/2	When SGR3/2 = 1, the trip signal of the I> stage is routed to TS1	0	2
SGR3/3	When SGR3/3 = 1, the start signal of the I>> stage is routed to TS1	0	4
SGR3/4	When SGR3/4 = 1, the trip signal of the I>> stage is routed to TS1	0	8
SGR3/5	When SGR3/5 = 1, the start signal of the I ₀ > stage is routed to TS1	0	16
SGR3/6	When SGR3/6 = 1, the trip signal of the I ₀ > stage is routed to TS1	0	32
SGR3/7	When SGR3/7 = 1, the start signal of the I ₀ >> stage is routed to TS1	0	64
SGR3/8	When SGR3/8 = 1, the trip signal of the I ₀ >> stage is routed to TS1	0	128
Checksum for the factory settings of switchgroup SGR3			0

Measured data

The measured current values are shown by the three right-most digits of the display. The value displayed at the present time is indicated by a LED indicator on the front panel.

Indicator	Measured data
I _{L1}	Line current on phase L1 as a multiple of the rated current I _n of the used energizing input (0...63 x I _n).
I _{L2}	Line current on phase L2 as a multiple of the rated current I _n of the used energizing input (0...63 x I _n).
I _{L3}	Line current on phase L3 as a multiple of the rated current I _n of the used energizing input (0...63 x I _n).
I ₀	Residual current as a multiple of the rated current I _n of the used energizing input (0...21 x I _n).

Recorded information

The left-most red digit shows the address of the register and the right-most three digits the recorded value.

The // symbol in the text indicates that the item following the symbol is found in a submenu.

Register/ STEP	Recorded information
1	Phase current I_{L1} displayed as a multiple of the rated current of the used input of the overcurrent unit. If the overcurrent unit starts or operates, the current value at the moment of operation is recorded in a memory stack. Any new operation adds a new value to the stack and moves the old values one place forward. Five values are memorized. If a sixth value is recorded, the oldest value is lost.
2	Phase current I_{L2} measured as a multiple of the rated current of the used input of the overcurrent unit. If the overcurrent unit starts or operates, the current value at the moment of operation is recorded in a memory stack. Any new operation adds a new value to the stack and moves the old values one place forward. Five values are memorized. If a sixth value is recorded, the oldest value is lost.
3	Phase current I_{L3} measured as a multiple of the rated current of the used input of the overcurrent unit. If the overcurrent unit starts or operates, the current value at the moment of operation is recorded in a memory stack. Any new operation adds a new value to the stack and moves the old values one place forward. Five values are memorized. If a sixth value is recorded, the oldest value is lost.
4	Maximum demand current value for a period of 15 minutes expressed in multiples of the rated current I_n of the used energizing input and based on the highest phase current. // Highest maximum demand current value recorded after the last relay reset.
5	Duration of the last start situation of the $I>$ stage as a percentage of the set operate time $t>$ or at IDMT characteristic the calculated operate time. At any new start the time counter starts from zero. Five start times are memorized. If a sixth start occurs the oldest start time is lost. When the concerned stage has operated, the counter reading is 100. // Number of starts of the low-set overcurrent stage $I>$, $n(I>) = 0...255$.
6	Duration of the last start situation of the $I>>$ stage as a percentage of the set operate time $t>>$. At any new start the time counter starts from zero. Five start times are memorized. If a sixth start occurs the oldest start time is lost. When the concerned stage has operated, the counter reading is 100. // Number of starts of the high-set overcurrent stage $I>>$, $n(I>>) = 0...255$.
7	Neutral current I_0 displayed as a multiple of the rated current of the used energizing input of the earth-fault unit. If the earth-fault unit starts or operates, the current value at the moment of operation is recorded in a memory stack. Any new operation adds a new value to the memory stack and moves the old values forward one place. Five values are memorized - if a sixth value is recorded, the oldest value will be lost.
8	Duration of the latest start situation of stage $I_0>$ as a percentage of the set operate time $t_0>$ or in IDMT operation characteristic the calculated operate time. At any new start the time counter starts from zero. Five start times are memorized. If a sixth start is recorded the oldest start time is lost. When the concerned stage has operated, the counter reading is 100. // Number of starts of the high-set overcurrent stage $I_0>$, $n(I_0>) = 0...255$.
9	Duration of the latest start situation of stage $I_0>>$ as a percentage of the set operate time $t_0>>$. At any new start the time counter starts from zero. Five start times are memorized. If a sixth start is recorded the oldest start time will be lost. When the concerned stage has operated, the counter reading is 100. // Number of starts of the high-set earth-fault stage $I_0>>$, $n(I_0>>) = 0...255$.

Register/ STEP	Recorded information
0	<p>Display of blocking signals and other external control signals. The right-most digit indicates the state of the blocking input of the module. The following states may be indicated: 0 = no blocking signal 1 = blocking or control signal BS active.</p> <p>The function of the external control signal on the relay unit is determined by the settings of switchgroup SGB</p> <p>From register "0" the TEST mode can be reached. In the TEST mode the start and trip signals of the relay module can be activated one by one. For further details see description "General characteristics of D type relay modules".</p>
A	<p>The address code of the protection relay module, required by the serial communication system. The address code is set at zero when no serial communication is to be used. The submenus of this register include the following settings or functions.</p> <ul style="list-style-type: none"> - 1st submenu. Selection of data transfer rate for the communication system. Selectable values 4800 Bd or 9600 Bd. - 2nd submenu. Bus communication monitor. If the relay is connected to bus communication unit, e.g. type SRIO 1000M, and the communication system is working properly, the monitor shows the value zero. When the communication system is out of operation the values 0...255 scroll in the monitor. - 3rd submenu. Password for allowing remote changing of setting values. The password must always be given via the serial port. - 4th submenu. Selection of main settings versus second settings. - 5th submenu. Setting of the operate time of the circuit breaker failure protection unit.
-	<p>Display dark. By pushing the STEP push-button the beginning of the display sequence is reached.</p>

Registers 1...9 are erased by pushing the RESET and PROGRAM push-buttons simultaneously. The contents of the registers are also erased if the auxiliary power supply of the module is interrupted. The address code of the relay module, the data transfer rate of the serial communication system, the password and the status of the main/second setting bank switch are not erased by a voltage failure. Instructions for setting the address and the data transfer rate are given in manual "General characteristics of D type relay modules".

tion system, the password and the status of the main/second setting bank switch are not erased by a voltage failure. Instructions for setting the address and the data transfer rate are given in manual "General characteristics of D type relay modules".

Menu and register chart

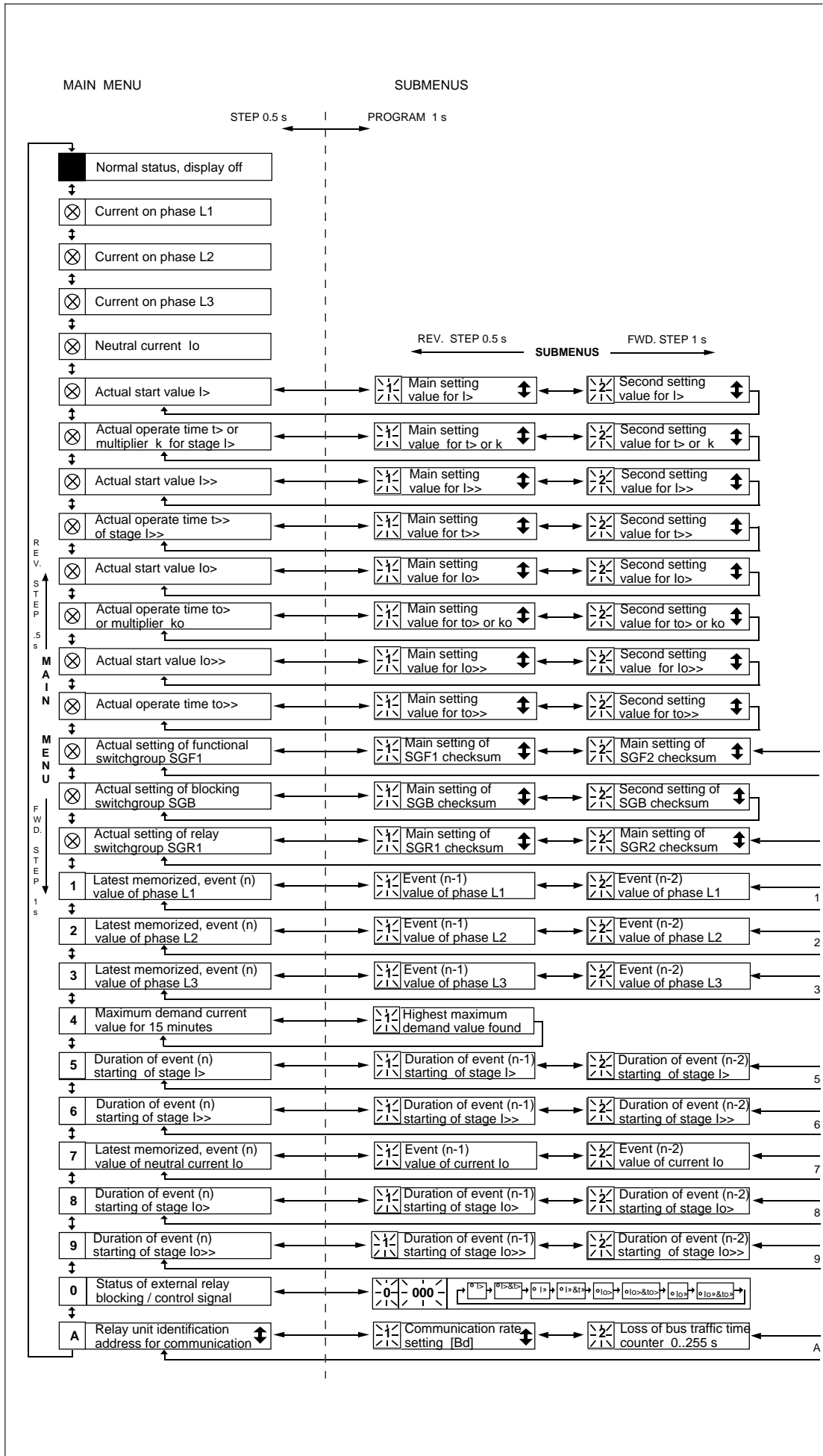

The procedures for entering a submenu or a setting mode and the method of performing the settings and the use of the TEST mode are

described in detail in the manual "General characteristics of D type relay modules". A short form guide to the operations is shown below.

Desired step or setting operation	Push-button	Action
Forward step in main menu or submenu	STEP	Push for more than 0.5 s
Rapid scan forward in main menu	STEP	Keep pushing
Reverse step in main menu or submenu	STEP	Push less than about 0.5 s
Entering submenu from main menu	PROGRAM	Push for 1 s (Active on release)
Entering or leaving setting mode	PROGRAM	Push for 5 s
Increasing value in setting mode	STEP	
Moving the cursor in setting mode	PROGRAM	Push for about 1 s
Storing a value in setting mode	STEP&PROGRAM	Push simultaneously
Erasing of memorized values and resetting of latched output relays	STEP&PROGRAM	
Resetting of latched output relays	PROGRAM	Note! Display must be off

Note! All parameters which can be set in the setting mode are indicated with the symbol \updownarrow .

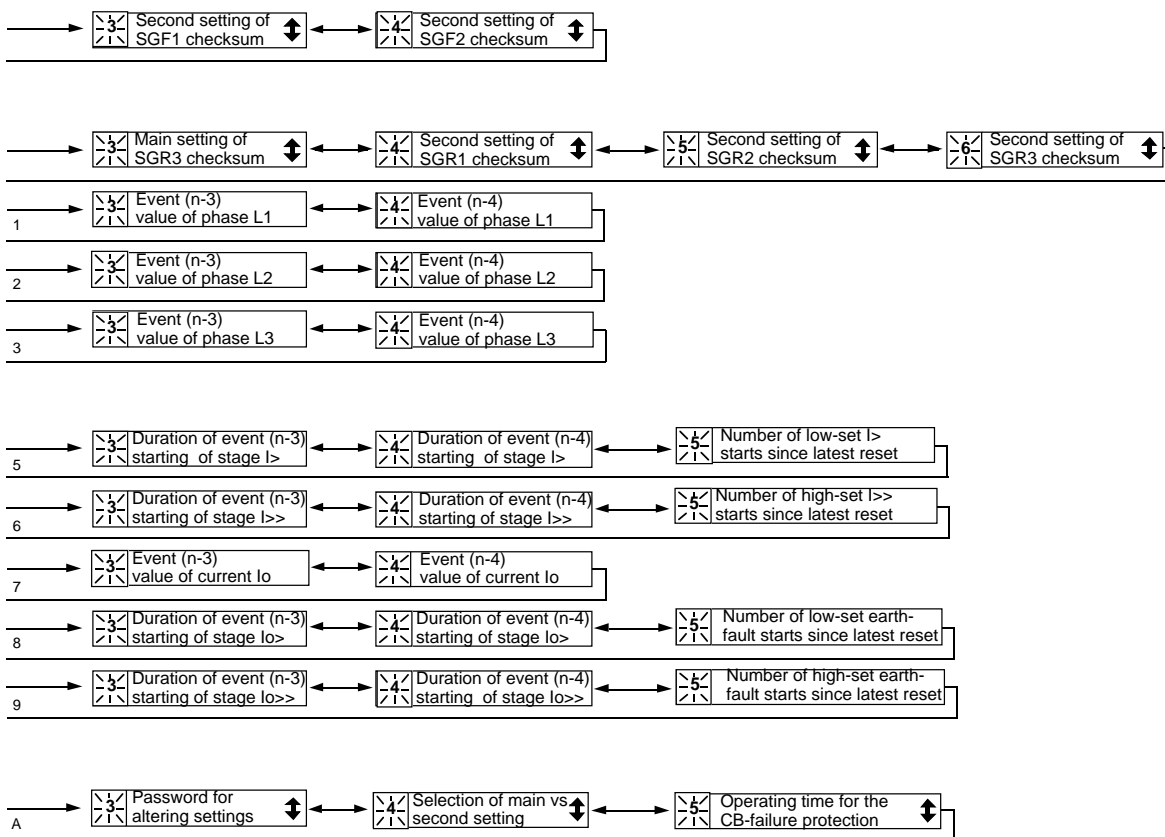

Time/current characteristic
(modified 2002-05)

The operation of the low-set overcurrent stage I_> and the low-set earth-fault stage I_{0>} is based on definite time or inverse time characteristic, as selected by the user. The operation characteristic is selected with switches 1...3 of switchgroup SGF1 for the overcurrent stage I_> and with switches SGF1/6...8 for the earth-fault stage I_{0>} (see chapter "Selector switches", page 7).

When IDMT characteristic has been selected, the operate time of the stage will be a function of the current; the higher the current, the shorter the operate time. The stage includes six time/current curve sets - four according to the BS 142 and IEC 60255 standards and two special curve sets, named RI type and RXIDG type, according to ABB standards.

IDMT characteristic

Four standard curves named extremely inverse, very inverse, normal inverse and long-time inverse are available. The relationship between current and time complies with the BS 142.1966 and IEC 60255-3 standards and can be expressed as follows:

$$t [s] = \frac{k \times \beta}{\left(\frac{I}{I_{>}}\right)^{\alpha} - 1}$$

where

t = operate time in seconds

k = time multiplier

I = measured current value

I_> = set start current value

The relay includes four time/current curve sets according to BS 142.1966 and IEC 60255-3.

The slope of the time/current curve sets is determined by the constants α and β as follows:

Slope of the time/current curve set	α	β
Normal inverse	0.02	0.14
Very inverse	1.0	13.5
Extremely inverse	2.0	80.0
Long-time inverse	1.0	120.0

According to the standard BS 142.1966 the normal current range is defined as 2...20 times the set start current. Additionally the relay must start at the latest when the current exceeds 1.3 times the set start current, when the time/current characteristic is normal inverse, very inverse or extremely inverse. At long-time inverse characteristic, the normal range is 2...7 times the set start current and the relay must start when the current exceeds 1.1 times the setting.

The following requirements with regard to operate time tolerances are specified in the standard (E denotes accuracy in per cent, - = not specified):

I/I _{>}	Normal inv.	Very inv.	Extremely inv.	Long-time inv.
2	2.22 E	2.34 E	2.44 E	2.34 E
5	1.13 E	1.26 E	1.48 E	1.26 E
7	-	-	-	1.00 E
10	1.01 E	1.01 E	1.02 E	-
20	1.00 E	1.00 E	1.00 E	-

In the defined normal current ranges, the inverse-time stages of the overcurrent and earth-fault unit SPCJ 4D29 comply with the tolerances of class 5 for all time/current curves.

The time/current curves specified in the BS-standards are illustrated in Fig. 3, 4, 5 and 6.

Note.

The actual operate time of the relay, presented in the graphs in Fig. 3...6, includes an additional filter and detection time plus the operate time of the trip output relay. When the operate time of the relay is calculated using the mathematical expression above, these additional times of about 30 ms in total have to be added to the time received.

<p>RI-type characteristic</p>	<p>The RI-type characteristic is a special characteristic used mainly in combination with existing mechanical relays. The characteristic is based on the following mathematical expression:</p> $t [s] = \frac{k}{0.339 - 0.236 \times \frac{I_{>}}{I}}$	<p>where</p> <p>t = operate time in seconds k = time multiplier I = measured phase current I> = set start current</p> <p>The graph of the characteristic is shown in Fig.7.</p>
<p>RXIDG-type characteristic</p>	<p>The RXIDG-type characteristic is a special characteristic used mainly for earth-fault protection, where a high degree of selectivity is needed also for high-resistance faults. With this characteristic, the protection relay need not to be directional and the scheme can operate without a pilot communication.</p>	<p>The characteristic is based on the following mathematical expression:</p> $t [s] = 5.8 - 1.35 \times \log_e \left(\frac{I}{k \times I_{>}} \right)$ <p>where</p> <p>t = operate time in seconds k = time multiplier I = measured phase current I> = set start current</p> <p>The graph of the characteristic is shown in Fig. 8.</p>
<p><i>Note!</i></p>	<p>If the set start current exceeds $2.5 \times I_n$, the maximum permitted continuous current carrying capacity of the energizing inputs ($4 \times I_n$) must be observed.</p> <p>At inverse time characteristic the effective setting range of the low-set overcurrent stage is $0.5 \dots 2.5 \times I_n$, although start current settings within the range $2.5 \dots 5.0 \times I_n$ can be set on the relay. At inverse time characteristic any start</p>	<p>current setting above $2.5 \times I_n$ of the low-set stage will be regarded as being equal to $2.5 \times I_n$.</p> <p>The operation of the low-set stage based on inverse time characteristic will be blocked by starting of the high-set stage. Then the operate time of the overcurrent or earth-fault unit is determined by the set operate time of the high-set stage at heavy fault currents.</p>

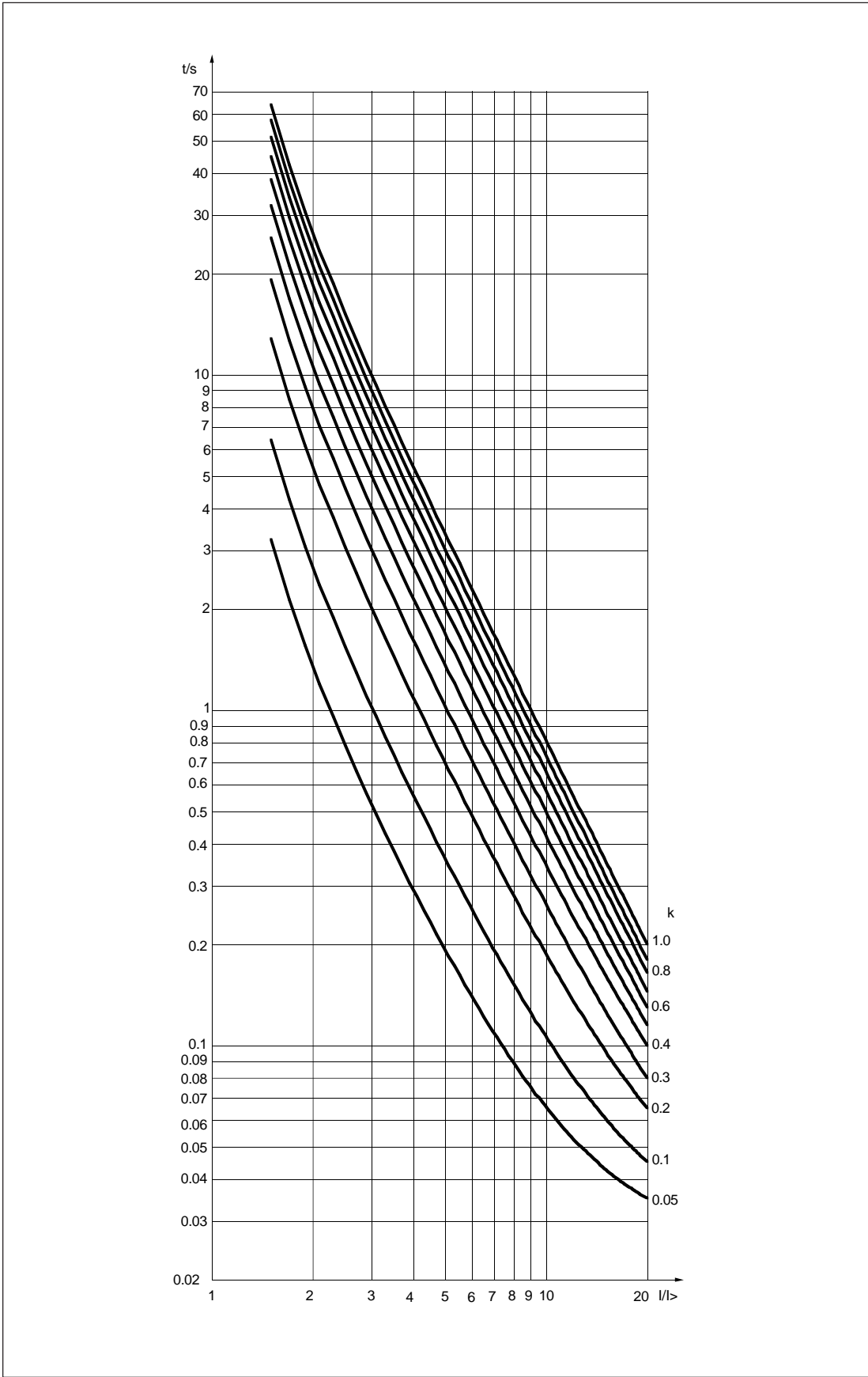

Fig. 3. Extremely inverse-time characteristics of the overcurrent and earth-fault unit SPCJ 4D29.

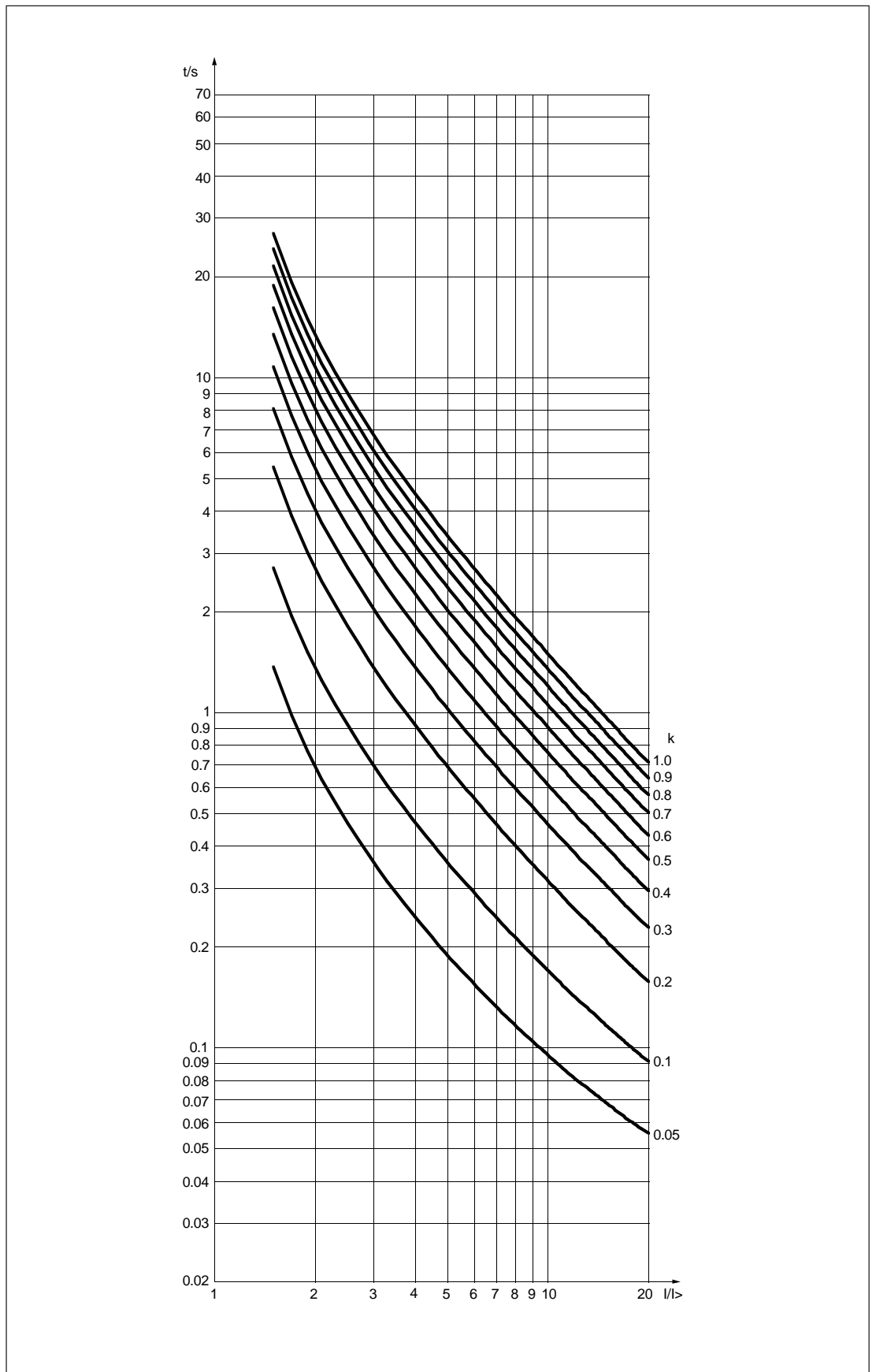

Fig. 4. Very inverse-time characteristics of the overcurrent and earth-fault unit SPCJ 4D29.

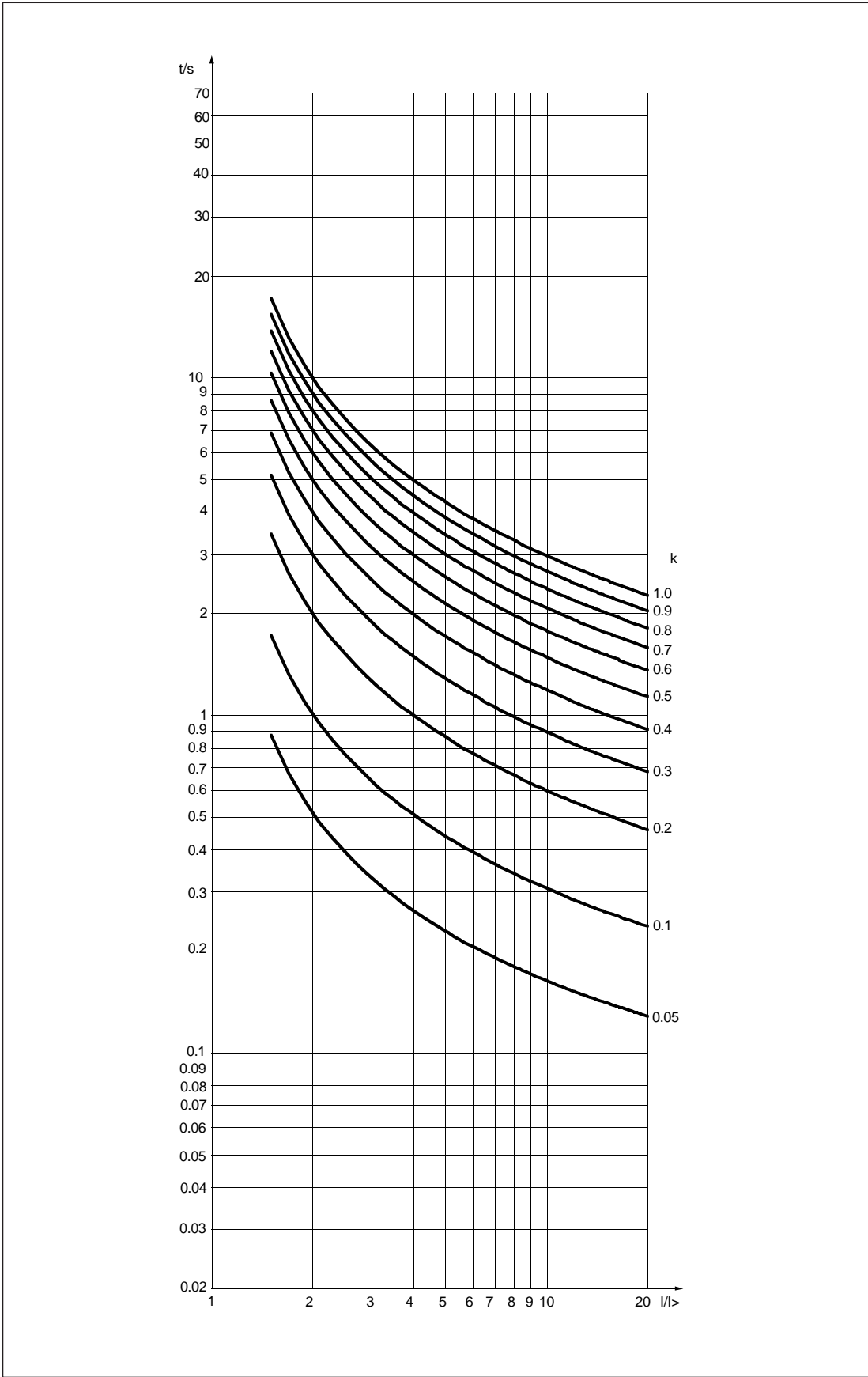

Fig. 5. Normal inverse-time characteristics of the overcurrent and earth-fault unit SPCJ 4D29.

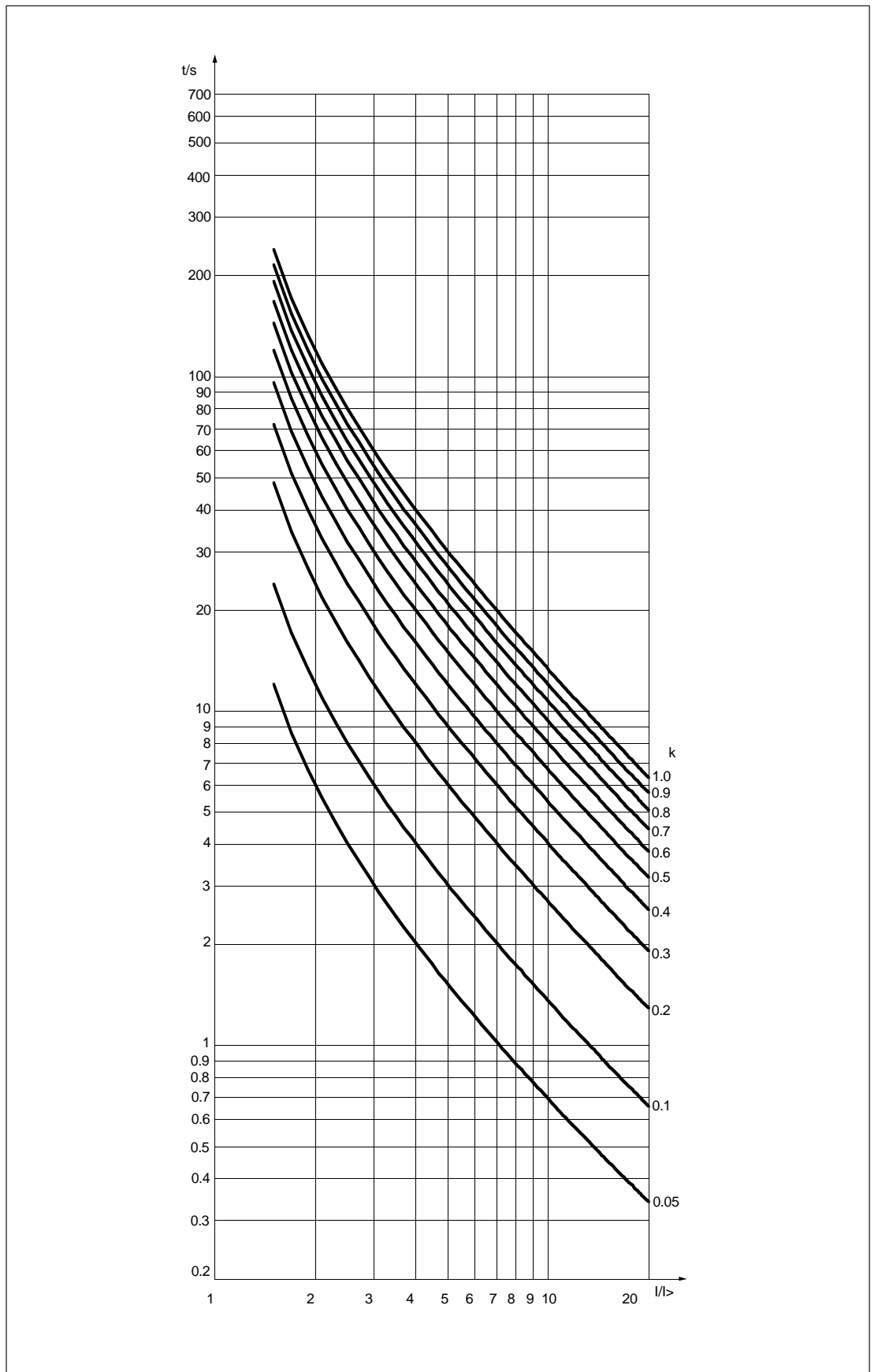

Fig. 6. Long-time inverse-time characteristics of the overcurrent and earth-fault unit SPCJ 4D29.

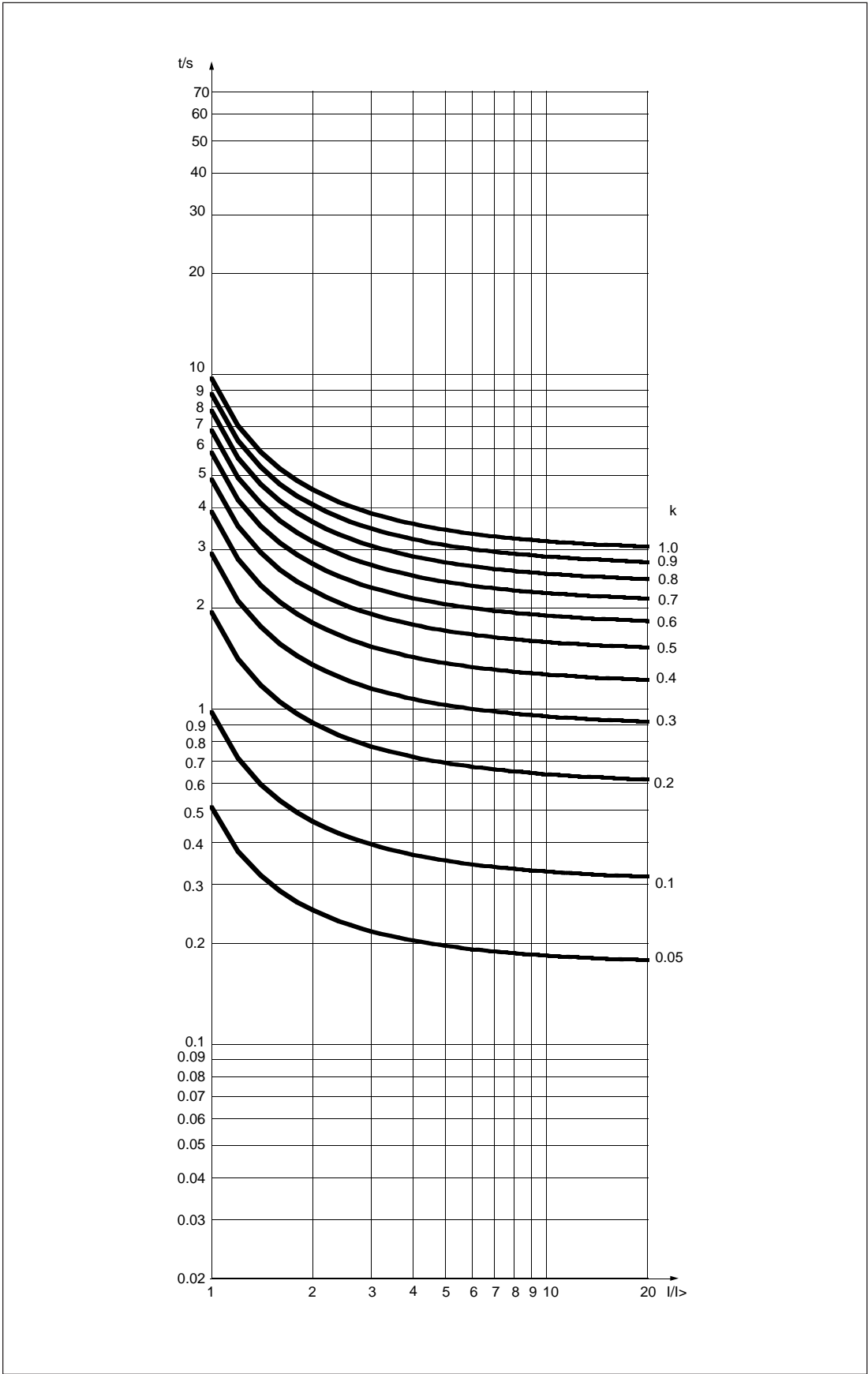

Fig. 7. RI-type inverse-time characteristics of the overcurrent and earth-fault unit SPCJ 4D29.

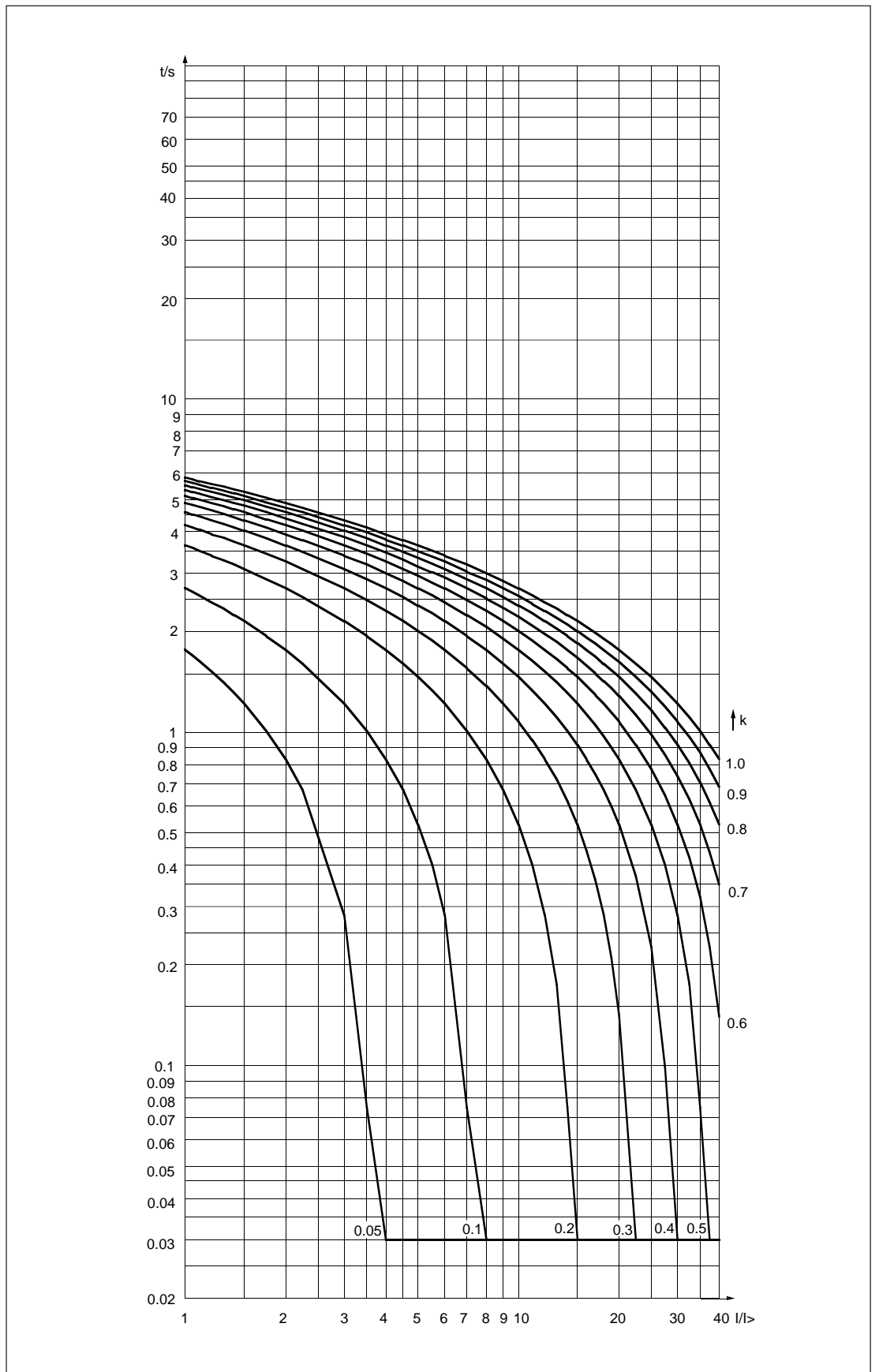

Fig. 8. RXIDG-type inverse-time characteristics of the overcurrent and earth-fault unit SPCJ 4D29.

Technical data

Low-set overcurrent stage I>

Start current	
- definite time characteristic	0.5...5.0 x I_n
- inverse time characteristic	0.5...2.5 x I_n
Start time, typ.	50 ms
Operation characteristic	
- definite time characteristic	
- operate time	0.05...300 s
- Inverse time characteristic acc. to BS 142 and IEC 60255-3	Extremely inverse Very inverse Normal inverse Long-time inverse
- special characteristic acc. to ABB standards	RI-type inverse RXIDG-type inverse
- time multiplier k	0.05...1.00
Reset time, typ.	40 ms
Retardation time	<30 ms
Drop-off/pick-up ratio, typ.	0.96
Operate time accuracy at definite time operation characteristic	± 2 % of set value or ± 25 ms
Operate time accuracy class E at inverse time characteristic	5
Operation accuracy	± 3 % of set value

High-set overcurrent stage I>>

Start current I>>	0.5...40.0 x I_n or ∞ , infinite
Start time, typ.	40 ms
Operate time	0.04...300 s
Reset time, typ.	40 ms
Retardation time	<30 ms
Drop-off/pick-up ratio, typ.	0.98
Operate time accuracy	± 2 % of set value or ± 25 ms
Operation accuracy	± 3 % of set value

Low-set earth-fault stage I₀>

Start current I ₀ >	0.1...0.8 x I_n
Start time, typ.	60 ms
Operation characteristic	
- definite time characteristic	
- operate time	0.05...300 s
- Inverse time characteristic acc. to BS 142 and IEC 60255-3	Extremely inverse Very inverse Normal inverse Long-time inverse
- special characteristic acc. to ABB standards	RI-type inverse RXIDG-type inverse
- time multiplier k ₀	0.05...1.00
Reset time, typ.	40 ms
Retardation time	<30 ms
Drop-off/pick-up ratio, typ.	0.96
Operate time accuracy at definite time operation characteristic	± 2 % of set value or ± 25 ms
Operate time accuracy class E at inverse time characteristic	5
Operation accuracy	± 3 % of set value

High-set earth-fault stage I₀>>

Start current I ₀ >>	0.1...10.0 x I _n or ∞, infinite
Start time, typ.	40 ms
Operate time	0.05...300 s
Reset time, typ.	40 ms
Drop-off/pick-up ratio, typ.	0.98
Operate time accuracy	±2% of set value or ±25 ms
Operation accuracy	±3% of set value

Serial communication parameters

Event codes

When the combined overcurrent and earth-fault relay module SPCJ 4D29 is connected to a data communication unit, e.g. SRIO 1000M, over a fibre-optic SPA bus, the module will spontaneously generate event markings e.g. for a printer. The events are printed out in the format: time, text and event code. The text can be defined and written by the user into the communication unit.

The events coded E1...E16 can be included in or excluded from the event reporting by writing an event mask V155 for the overcurrent events and V156 for earth-fault events to the module over the SPA bus. The event masks are binary numbers coded to decimal numbers. The event codes E1...E8 are represented by the numbers 1, 2, 4...128. An event mask is formed by multiplying the above numbers either by 0, event not included in reporting, or 1, event included in reporting and by adding the numbers received. Check for the procedure of a manual calculation of the checksum.

The event masks V155 and V156 may have a value within the range 0...255. The default value of the combined overcurrent and earth-fault relay module SPCJ 4D29 is 85 both for overcurrent and earth-fault events, which means that all start and operate events are included in the reporting, but not the resetting. Check for

the procedure of a manual calculation of the checksum.

The output signals are monitored by codes E17...E26 and these events can be included in or excluded from the event reporting by writing an event mask V157 to the module. The event mask is a binary number coded to a decimal number. The event codes E17...E26 are represented by the numbers 1, 2, 4...512. An event mask is formed by multiplying the above numbers either by 0, event not included in reporting or 1, event included in reporting and by adding the numbers received. Check for the procedure of a manual calculation of the checksum.

The event mask V157 may have a value within the range 0...1024. The default value of the combined overcurrent and earth-fault relay module SPCJ 4D29 is 768 which means that only the operations are included in the reporting.

Codes E50...E54 and the events represented by these cannot be excluded from the reporting.

More information about the serial communication over the SPA bus can be found in the manual "SPA bus communication protocol", code No 34 SPACOM 2 EN1.

Event codes of the combined overcurrent and earth-fault relay module SPCJ 4D29:

Code	Event	Weight factor	Default value of the factor
E1	Starting of stage I>	1	1
E2	Resetting of starting of stage I>	2	0
E3	Operation of stage I>	4	1
E4	Resetting of operation of stage I>	8	0
E5	Starting of stage I>>	16	1
E6	Resetting of starting of stage I>>	32	0
E7	Operation of stage I>>	64	1
E8	Resetting of operation of stage I>>	128	0
Default checksum for mask V155			85

Code	Event	Weight factor	Default value of the factor
E9	Starting of stage I ₀ >	1	1
E10	Resetting of starting of stage I ₀ >	2	0
E11	Operation of stage I ₀ >	4	1
E12	Resetting of operation of stage I ₀ >	8	0
E13	Starting of I ₀ >> stage	16	1
E14	Resetting of starting of stage I ₀ >>	32	0
E15	Operation of stage I ₀ >>	64	1
E16	Resetting of operation of stage I ₀ >>	128	0
Default checksum for mask V156			85

E17	Output signal TS1 activated	1	0
E18	Output signal TS1 reset	2	0
E19	Output signal SS1 activated	4	0
E20	Output signal SS1 reset	8	0
E21	Output signal SS2 activated	16	0
E22	Output signal SS2 reset	32	0
E23	Output signal SS3 activated	64	0
E24	Output signal SS3 reset	128	0
E25	Output signal TS2 activated	256	1
E26	Output signal TS2 reset	512	1
Default checksum for mask V157			768

E50	Restarting	*	-
E51	Overflow of event register	*	-
E52	Temporary interruption in data communication	*	-
E53	No response from the module over the data communication	*	-
E54	The module responds again over the data communication	*	-

- 0 not included in the event reporting
- 1 included in the event reporting
- * no code number
- cannot be programmed

Note!

The event codes E52-E54 are generated by the data communication unit (SACO 100M, SRIO 500M, SRIO 1000M, etc.)

Data to be transferred via the fibre-optic serial bus

In addition to the spontaneous data transfer the SPA bus allows reading of all input values (I-values), setting values (S-values), information recorded in the memory (V-values), and some other data. Further, part of the data can be altered by commands given over the SPA bus.

All the data are available in channel 0.

R = data to be read from the unit

W = data to be written to the unit

(P) = writing enabled by password

Data	Code	Data direction	Values
INPUTS			
Current on phase L1	I1	R	0...63 x I_n
Current on phase L2	I2	R	0...63 x I_n
Current on phase L3	I3	R	0...63 x I_n
Neutral current	I4	R	0...21 x I_n
Blocking or control signal	I5	R	0 = no blocking 1 = external blocking or control signal active
OUTPUTS			
Starting of stage I>	O1	R	0 = I> stage not started 1 = I> stage started
Operation of stage I>	O2	R	0 = I> stage not tripped 1 = I> stage tripped
Starting of stage I>>	O3	R	0 = I>> stage not started 1 = I>> stage started
Operation of stage I>>	O4	R	0 = I>> stage not tripped 1 = I>> stage tripped
Starting of stage I ₀ >	O5	R	0 = I ₀ > stage not started 1 = I ₀ > stage started
Operation of stage I ₀ >	O6	R	0 = I ₀ > stage not tripped 1 = I ₀ > stage tripped
Starting of stage I ₀ >>	O7	R	0 = I ₀ >> stage not started 1 = I ₀ >> stage started
Operation of stage I ₀ >>	O8	R	0 = I ₀ >> stage not tripped 1 = I ₀ >> stage tripped
Signal START1 TS1	O9	R, W (P)	0 = signal not active 1 = signal active
Signal START2 SS1	O10	R, W (P)	0 = signal not active 1 = signal active
Signal ALARM1 SS2	O11	R, W (P)	0 = signal not active 1 = signal active
Signal ALARM2 SS3	O12	R, W (P)	0 = signal not active 1 = signal active
Signal TRIP TS2	O13	R, W (P)	0 = signal not active 1 = signal active
Operate output relays	O41	R, W (P)	0 = not operated 1 = operated

Data	Code	Data direction	Values
Memorized I> start signal	O21	R	0 = signal not active 1 = signal active
Memorized I> operate signal	O22	R	0 = signal not active 1 = signal active
Memorized I>> start signal	O23	R	0 = signal not active 1 = signal active
Memorized I>> operate signal	O24	R	0 = signal not active 1 = signal active
Memorized I ₀ > start signal	O25	R	0 = signal not active 1 = signal active
Memorized I ₀ > operate signal	O26	R	0 = signal not active 1 = signal active
Memorized I ₀ >> start signal	O27	R	0 = signal not active 1 = signal active
Memorized I ₀ >> operate signal	O28	R	0 = signal not active 1 = signal active
Memorized output signal TS1	O29	R	0 = signal not active 1 = signal active
Memorized output signal SS1	O30	R	0 = signal not active 1 = signal active
Memorized output signal SS2	O31	R	0 = signal not active 1 = signal active
Memorized output signal SS3	O32	R	0 = signal not active 1 = signal active
Memorized output signal TS2	O33	R	0 = signal not active 1 = signal active

PRESENT SETTING VALUES

Present start value for stage I>	S1	R	0.5...5.0 x I _n
Present operate time or time multiplier for stage I>	S2	R	0.05...300 s 0.05...1.0
Present start value for stage I>>	S3	R	0.5...40 x I _n 999 = not in use (∞)
Present operate time for stage I>>	S4	R	0.04...300 s
Present start value for stage I ₀ >	S5	R	0.1...0.8 x I _n
Present operate time or time multiplier for stage I ₀ >	S6	R	0.05...300 s 0.05...1.0
Present start value for stage I ₀ >>	S7	R	0.1...10.0 x I _n 999 = not in use (∞)
Present operate time for stage I ₀ >>	S8	R	0.05...300 s
Present checksum of switchgroup SGF1	S9	R	0...255
Present checksum of switchgroup SGF2	S10	R	0...255
Present checksum of switchgroup SGB	S11	R	0...255
Present checksum of switchgroup SGR1	S12	R	0...255
Present checksum of switchgroup SGR2	S13	R	0...255
Present checksum of switchgroup SGR3	S14	R	0...255

Data	Code	Data direction	Values
MAIN SETTING VALUES			
Start current of stage I>, main setting	S21	R, W (P)	0.5...5.0 x I _n
Operate time or time multiplier of stage I>, main setting	S22	R, W (P)	0.05...300 s 0.05...1.0
Start current of stage I>>, main setting	S23	R, W (P)	0.5...40.0 x I _n
Operate time of stage I>>, main setting	S24	R, W (P)	0.04...300 s
Start current of stage I ₀ >, main setting	S25	R, W (P)	0.1...0.8 x I _n
Operate time or time multiplier of stage I ₀ >, main setting	S26	R, W (P)	0.05...300 s 0.05...1.0
Start current of stage I ₀ >>, main setting	S27	R, W (P)	0.1...10.0 x I _n
Operate time of stage I ₀ >>, main setting	S28	R, W (P)	0.05...300 s
Checksum of switchgroup SGF1, main setting	S29	R, W (P)	0...255
Checksum of switchgroup SGF2, main setting	S30	R, W (P)	0...255
Checksum of switchgroup SGB, main setting	S31	R, W (P)	0...255
Checksum of switchgroup SGR1, main setting	S32	R, W (P)	0...255
Checksum of switchgroup SGR2, main setting	S33	R, W (P)	0...255
Checksum of switchgroup SGR3, main setting	S34	R, W (P)	0...255
SECOND SETTING VALUES			
Start current of stage I>, second setting	S41	R, W (P)	0.5...5.0 x I _n
Operate time or time multiplier of stage I>, second setting	S42	R, W (P)	0.05...300 s 0.05...1.0
Start current of stage I>>, second setting	S43	R, W (P)	0.5...40.0 x I _n
Operate time of stage I>>, second setting	S44	R, W (P)	0.04...300 s
Start current of stage I ₀ >, second setting	S45	R, W (P)	0.1...0.8 x I _n
Operate time or time multiplier of stage I ₀ >, second setting	S46	R, W (P)	0.05...300 s 0.05...1.0
Start current of stage I ₀ >>, second setting	S47	R, W (P)	0.1...10.0 x I _n
Operate time of stage I ₀ >>, second setting	S48	R, W (P)	0.05...300 s

Data	Code	Data direction	Values
Checksum of switchgroup SGF1, second setting	S49	R, W (P)	0...255
Checksum of switchgroup SGF2, second setting	S50	R, W (P)	0...255
Checksum of switchgroup SGB, second setting	S51	R, W (P)	0...255
Checksum of switchgroup SGR1, second setting	S52	R, W (P)	0...255
Checksum of switchgroup SGR2, second setting	S53	R, W (P)	0...255
Checksum of switchgroup SGR3, second setting	S54	R, W (P)	0...255
Operate time for the circuit breaker failure protection	S61	R, W (P)	0.1...1.0 s

RECORDED AND MEMORIZED PARAMETERS

Current on phase L1 at starting or operation	V11...V51	R	0...63 x I _n
Current on phase L2 at starting or operation	V12...V52	R	0...63 x I _n
Current on phase L3 at starting or operation	V13...V53	R	0...63 x I _n
Neutral current I ₀ at starting or operation	V14...V54	R	0...21 x I _n
Duration of the latest start situation of stage I>	V15...V55	R	0...100%
Duration of the latest start situation of stage I>>	V16...V56	R	0...100%
Duration of the latest start situation of stage I ₀ >	V17...V57	R	0...100%
Duration of the latest start situation of stage I ₀ >>	V18...V58	R	0...100%
Maximum demand current for 15 min.	V1	R	0...2.5 x I _n
Number of starts of stage I>	V2	R	0...255
Number of starts of stage I>>	V3	R	0...255
Number of starts of stage I ₀ >	V4	R	0...255
Number of starts of stage I ₀ >>	V5	R	0...255
Phase conditions during trip	V6	R	1 = I _{L3} >, 2 = I _{L2} >, 4 = I _{L1} >, 8 = I ₀ > 16 = I _{L3} >>, 32 = I _{L2} >> 64 = I _{L1} >>, 128 = I ₀ >>
Operation indicator	V7	R	0...9
Highest maximum demand current 15 minute value	V8	R	0...2.55 x I _n

CONTROL PARAMETERS

Resetting of output relays at latched output	V101	W	1 = output relays and all information from the display are reset
Resetting of output relays and recorded data	V102	W	1 = output relays and registers are reset

Data	Code	Data direction	Values
Remote control of settings	V150	R, W	0 = main settings activated 1 = second settings activated, see chapter "Description of function"
Event mask word for overcurrent events	V155	R, W	0...255, see chapter "Event codes"
Event mask word for earth-fault events	V156	R, W	0...255, see chapter "Event codes"
Event mask word for output signal events	V157	R, W	0...1023, see chapter "Event codes"
Opening of password for remote settings	V160	W	1...999
Changing or closing of password for remote settings	V161	W (P)	0...999
Activating of self-supervision output	V165	W	1 = self-supervision output is activated and IRF LED turned on 0 = normal mode
EEPROM formatting (will restore factory settings)	V167	W (P)	2 = formatting, to be followed by power reset
Internal fault code	V169	R	0...255
Data comm. address of the module	V200	R, W	1...254
Data transfer rate	V201	R, W	4800 or 9600 Bd (R) 4.8 or 9.6 kBd (W)
Software version symbol	V205	R	037_ or 056_
Event register reading	L	R	time, channel number and event code
Re-reading of event register	B	R	time, channel number and event code
Type designation of the module	F	R	SPCJ 4D29
Reading of module status data	C	R	0 = normal state 1 = module been subject to automatic reset 2 = overflow of event regist. 3 = events 1 and 2 together
Resetting of module state data	C	W	0 = resetting
Time reading and setting	T	R, W	00.000...59.999 s

The event register can be read by L-command only once. Should a fault occur e.g. in the data transfer, the contents of the event register may be re-read using the B-command. When required, the B-command can be repeated. Generally, the control data communicator SACO 100M reads the event data and forwards them to the output device continuously. Under normal conditions the event register of the module is empty. The data communicator also resets abnormal status data, so this data is normally a zero.

The setting values S1...S14 are the setting values used by the protection functions. All the settings can be read or written. A condition for writing is that remote set password has been opened.

When changing settings, the relay unit will check that the variable values are within the ranges specified in the technical data of the module. If a value beyond the limits is given to the unit, either manually or by remote setting, the unit will not perform the store operation but will keep the previous setting.

Fault codes

Shortly after the internal self-supervision system has detected a permanent relay fault, the red IRF indicator is lit and the output relay of the self-supervision system operates. Further, in most fault situations, an auto-diagnostic fault code is shown on the display. This fault code consists of a red figure 1 and a green code number which

indicates the fault type. When a fault code appears on the display, the code number should be recorded and given to the authorized repair shop when overhaul is ordered. In the table below some fault codes that might appear on the display of the SPCJ 4D29 module are listed:

Fault code	Type of error in module
4	Faulty trip relay path or missing output relay card
30	Faulty program memory (ROM)
50	Faulty work memory (RAM)
51	Parameter memory (EEPROM) block 1 faulty
52	Parameter memory (EEPROM) block 2 faulty
53	Parameter memory (EEPROM) block 1 and block 2 faulty
54	Parameter memory (EEPROM) block 1 and block 2 faulty with different checksums
56	Parameter memory (EEPROM) key faulty. Format by writing a "2" to variable V167
195	Too low value in reference channel with multiplier 1
131	Too low value in reference channel with multiplier 5
67	Too low value in reference channel with multiplier 25
203	Too high value in reference channel with multiplier 1
139	Too high value in reference channel with multiplier 5
75	Too high value in reference channel with multiplier 25
252	Faulty filter on I ₀ channel
253	No interruptions from the A/D-converter



ABB Oy

Substation Automation
P.O.Box 699
FIN-65101 VAASA
Finland
Tel. +358 (0)10 22 11
Fax.+358 (0)10 22 41094
www.abb.com/substationautomation