

Feeder Protection REF601 IEC

Protection and Control



ABB

Sensor enabled Protection and Control IEDs for Distribution Substations

Area of application

REF601 is a numerical feeder protection relay, intended for the protection and control of utility and industrial power systems, in primary and secondary distribution networks.

The relay provides protection for over-head lines, cable and transformer feeders in solidly earthed, resistance earthed or isolated networks. The new feeder protection relay is designed to unleash the advantages of Rogowski coil current sensors for protection and control in medium voltage applications.

Protection and control

REF601 offers three-stage overcurrent and two-stage earth-fault protection functions. Transformer inrush detector function is also incorporated to prevent unwarranted trippings. The relay can measure earth current either by internal calculation or by external core balance current transformer input. The low-set stages of overcurrent and earth-fault protection are equipped with selectable DMT and IDMT characteristics. The relay features standard IDMT characteristics – Normal Inverse (NI), Very Inverse (VI), Extremely Inverse (EI) & Long-time Inverse (LI) and a special characteristic RI inverse (RI) for better co-ordination with rest of the network.

The relay integrates basic control functionality. Apart from display of data and parameter settings, the user friendly local human-machine interface (HMI) supports control of one circuit breaker with dedicated control push buttons.

To protect the relay from unauthorized access and to maintain the integrity of information, the relay is armed with a three level, role-based user authentication system with individual password for the operator, engineer and administrator level.

Easy to use

Five dedicated LEDs of REF601 clearly indicate the status of relay and protection functions while the LCD presents online measurements, settings, events and recorded data allowing them to be rapidly analyzed and dealt with.

The optional communication feature extends local monitoring and control facility of HMI to remote automation systems.

Pre-configured inputs and outputs of the relay minimize the engineering effort for adaptation in variety of applications. A single wide range auxiliary supply eliminates the ordering variants of power supply thus minimizing the risk of inventory or damage. The relay also boasts a press-fit design for effortless installation on panels.

Sensor technology for superior performance

Sensors based on alternative principles have been introduced as successors to instrument transformers in order to obtain equipment size reduction, performance improvement and better standardization.

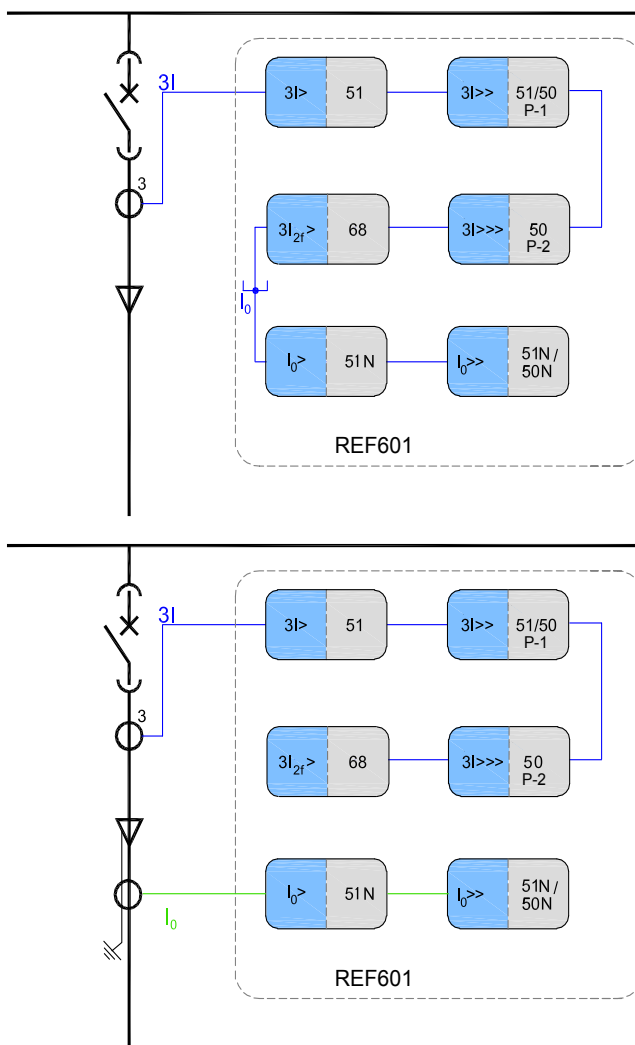



Rogowski coil is one such principle, where a toroidal coil without an iron core is placed around the primary conductor in the same way as the secondary winding in a current transformer. However, the output signal from the Rogowski coil is not current, but a voltage. Due to the absence of ferromagnetic core, the sensor is linear up to the highest currents.

Although this principle is far from new, it is now possible to exploit the advantages of sensors with the latest offering of numerical relays like REF601 and matching sensors type KECA and KEVCR.

The wide measurement range of sensor with high accuracy eliminates the need for high variants of conventional instrument transformers, resulting in simplified engineering & logistics and reduced inventory. The low level voltage signals and integrated secondary cables contribute to easy and fast installation with enhanced safety.

Compact and flexible

REF601 has a small mounting depth and is free of any loose mounting accessories. The form factor of the relay is particularly suited for mounting on the circuit breakers VD4 & HD4 while the press-fit mounting feature of the relay makes it suitable for quick and easy installation on switchgear panels. Complimented with sensors, the REF601 also forms a part of ABB's offering of integrated apparatus.

Non-volatile memory

With its non-volatile memory, the REF601 relay retains the fault data even after an auxiliary power failure. The relay is inherently reliable and features excellent immunity to external electromagnetic interference.

Self-supervision and Test function

To ensure protection availability and security, the REF601 relays feature extensive self-supervision of the electronics and software. The self-supervision system manages runtime fault situations and alerts the user to any internal relay faults. When a permanent relay fault is detected, all protection stages and outputs will be blocked to prevent the relay from malfunctioning.

The relay supports built-in test mode which enables user to test relay HMI and trip outputs.



REF601 highlights

- Sensor input for phase current
- External CBCT input for earth current
- Internal calculation of earth current
- Three-stage overcurrent protection
- Two-stage earth-fault protection
- Magnetizing inrush detection
- Control of circuit breaker
- Local and remote control
- Five event logs
- Two fault records of analogue value
- Non-resettable trip counter
- On-line measurements
- Comprehensive local HMI
- Universal auxiliary supply rating
- Circuit breaker or panel mounting
- Optional Modbus communication
- Non-volatile memory
- Access control
- Self-supervision
- Built-in test functionality

Protection functions	IEC	ANSI
Three phase overcurrent protection, low-set stage	3I>	51
Three phase overcurrent protection, high-set stage	3I>>	50/51
Three phase overcurrent protection, super high-set stage	3I>>>	50
Non-directional earth fault protection, low-set stage	I ₀ >	51N
Non-directional earth fault protection, high-set stage	I ₀ >>	50N
Transformer inrush detector	3I _{2r} >	68
Control		
Circuit breaker control	1 ↔ 0 CB	
Measurement		
Measurement in primary and secondary terms		
Inputs and outputs		
Phase current measurement		
<ul style="list-style-type: none"> Three sensor inputs with four selectable primary currents 		
Earth current measurement		
<ul style="list-style-type: none"> Internally in relay Externally through 1A core balance current transformer 		
Binary inputs		
<ul style="list-style-type: none"> 2 nos. for remote trip and remote reset 2 nos. for remote breaker close and open operation 		
Binary outputs		
<ul style="list-style-type: none"> 1 No. Trip / Breaker open command output 1 No. Trip output 2 Nos. signalling contacts for overcurrent & earth fault 1 No. contacts for breaker close 1 no. signalling contact for unit ready / internal relay fault 		
Power supply		
Universal supply		
<ul style="list-style-type: none"> Rated input voltage 24 - 240V AC / DC Tolerances : 85 ... 110% for AC, 70 ... 120% for DC 		

Indications

Protection trip : Red
 Protection start : Yellow
 Unit ready / IRF : Green
 Phase fault trip : Red
 Earth fault trip : Red

Compatible Sensors

KEVCR : For integrated circuit-breakers type VD4 / HD4
 KECA : For other applications where relay is panel mounted

Communication

MODBUS RTU on RS485 (optional)

Dimensions

160 mm height, 130 mm width, 101 mm depth, weight 1.2 kg



ABB Ltd.
 Distribution Automation
 Maneja Works
 Vadodara - 390 013, India
 Phone: +91 265 2604386
 Fax: +91 265 2638922
www.abb.com/substationautomation