

Station Automation COM600

An affordable alternative to traditional network enterprise systems local to each substation

The COM600 is an affordable, flexible substation automation device that provides localized automation tasks. The COM600 gathers data from protection and control devices, such as relays and meters, combining different communication protocols into one common contact point. It provides access to these devices through an easy to use web browser. This same web technology can be used to transfer information to a network enterprise system and issue commands.

COM600 is a great choice for customers:

- Who have or desire a data acquisition structure
- Who want localized and remote data acquisition
- With small, rural, or remote substations
- Who want drag and drop configuration of HMI using basic graphic elements

Benefits

- Web based HMI provides a simple user interface for device control and management - NO complex HMI software that needs to be installed and maintained
- Logic processor allows anything from simple control schemes to advanced feeder restoration or load shed functions
- Data historian provides a common point for data recording, alarms, performance monitoring, etc.
- Easily upgradable functionality --- buy only what you need now, upgrade later
- Can stand alone or complement network enterprise systems
- No moving parts increases reliability and durability
- All connections easily accessible at front of unit
- Easy to use windows based software included
- Compact, robust design well suited for harsh environments
- Substation design templates provide straightforward and expedient engineering, installation, and commissioning
- Low cost localized SCADA system provides access for substation technicians
- Environmentally friendly RoHS compliant design
- Remotely issued commands increase operator safety
- Standard 12 year warranty
- Integrates all substation devices into a single contact point
- Can communicate with any device that uses open protocols (DNP, Modbus or IEC 61850), allowing easy integration into systems with multiple product brands
- Available Ethernet, serial, and LON communication ports enable the COM600 to connect to a wide array of devices
- Simplified commissioning and troubleshooting using comprehensive diagnostic features
- By superior user access control and substation security, get the benefits of IED integration within NERC-compliant framework



Overview of a utility substation using Station Automation COM600

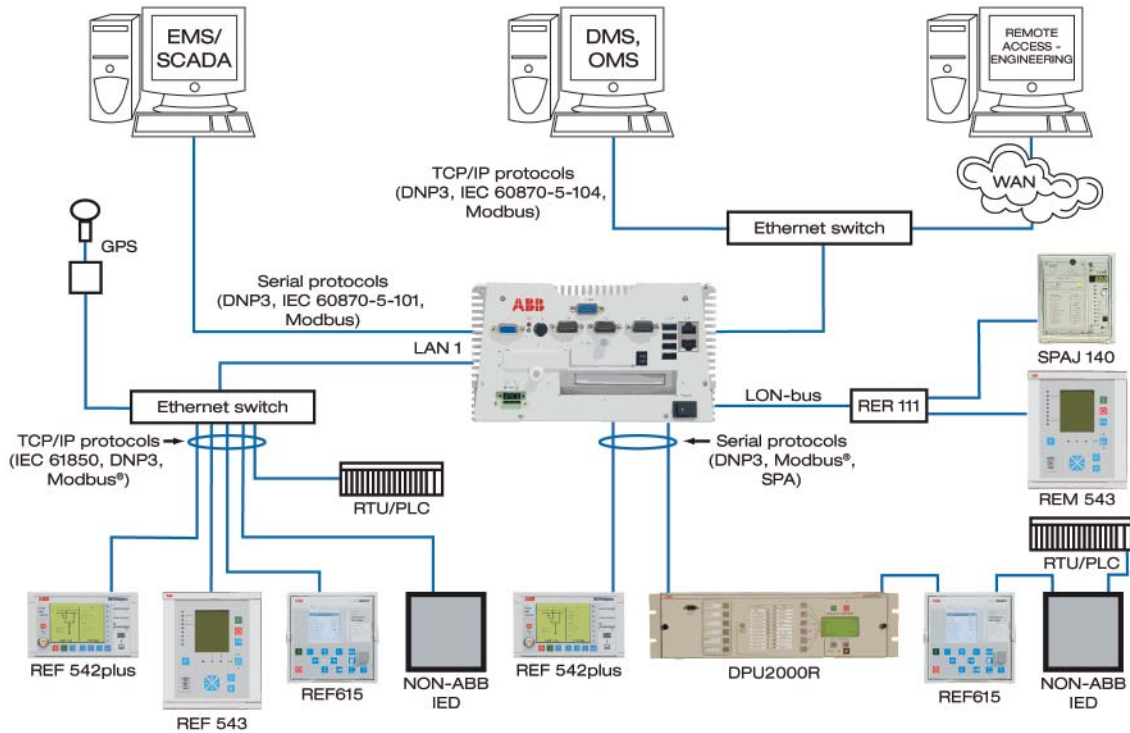

1VAL456801-FL Rev. C January 2010

For more information please contact:

**ABB Inc.
Distribution Automation**

655 Century Point
Lake Mary, FL 32746 USA
Phone: +1 407 732 2000
Fax: +1 407 732 2335

4300 Coral Ridge Drive
Coral Springs, Florida 33065
Phone: +1 954 752 6700
Fax: +1 954 345 5329

www.abb.com/substationautomation

Copyright 2009 ABB.
All rights reserved.