

1. About this manual	5
1.1. Copyrights	5
1.2. Trademarks	5
1.3. Guarantee	5
1.4. General	5
1.5. Use of symbols	6
1.6. Terminology	7
1.7. Abbreviations	7
1.8. Related documents	8
1.9. Document revisions	8
2. Safety	9
3. Introduction	11
3.1. Features	11
3.2. Use of the REA 101 relay	12
4. Connection diagram	13
5. Operation	15
5.1. Overcurrent detection unit	15
5.2. Light detection unit	15
5.3. Sensitivity of sensors	16
5.3.1. Sensitivity of fiber sensors	17
5.3.2. Sensitivity of lens sensors	17
5.4. Trip output	18
5.5. Ports A and B for connecting extension units	18
5.6. Optolink communication	19
5.7. Circuit-breaker failure protection	19
5.8. Self-supervision unit	20
5.9. Front panel	21
5.10. Functions of LEDs, push-buttons and switches	22
5.10.1. "Reset" push-button	22
5.10.2. "Trip Condition" key switch with "Current&Light" LED	23
5.10.3. "Light Ref. Level Adj." potentiometer	23
5.10.4. Switchgroup SG1	23
5.10.5. Switchgroup SG2 (optolink communication)	24
5.10.6. Switchgroup SG3 (circuit-breaker failure protection)	25
5.10.7. Switchgroup SG4	26
6. Rear panel	27
7. Connections	29
7.1. Connector X1	29
7.2. Connector X2	29
7.3. Connector X3	29

7.4. Connectors X4 and X5	30
7.5. Connectors X6 and X7	30
7.6. Connectors X8 and X9	30
7.7. Connectors X10 and X11	30
8. Commissioning	31
8.1. Checking the voltages	31
8.2. Setting the relay	31
8.3. Testing the arc protection system	32
8.4. Setting the light reference level	32
9. Dimension drawings	33
9.1. Mounting alternatives	33
10.Application examples	37
10.1.Remember when constructing applications	37
10.2.Application examples	37
11.Technical data	51
12.Order information	55
12.1.REA 10_ units	55
12.2.Fiber sensors	55
12.3.Lens sensors	56
12.4.Connection cables	56
13.Appendix A: Glass fiber optolink connection	59

1. About this manual

1.1. Copyrights

The information in this document is subject to change without notice and should not be construed as a commitment by ABB Oy. ABB Oy assumes no responsibility for any errors that may appear in this document.

In no event shall ABB Oy be liable for direct, indirect, special, incidental or consequential damages of any nature or kind arising from the use of this document, nor shall ABB Oy be liable for incidental or consequential damages arising from use of any software or hardware described in this document.

This document and parts thereof must not be reproduced or copied without written permission from ABB Oy, and the contents thereof must not be imparted to a third party nor used for any unauthorized purpose.

The software or hardware described in this document is furnished under a license and may be used, copied, or disclosed only in accordance with the terms of such license.

Copyright © 2005 ABB Oy
All rights reserved.

1.2. Trademarks

ABB is a registered trademark of ABB Group.

All other brand or product names mentioned in this document may be trademarks or registered trademarks of their respective holders.

1.3. Guarantee

Please inquire about the terms of guarantee from your nearest ABB representative.

1.4. General

This manual provides thorough information on the operation of the Arc Protection Relay REA 101 (later REA 101).

1.5. Use of symbols

This publication includes warning, caution, and information icons that point out safety related conditions or other important information. It also includes tip icons to point out useful information to the reader. The corresponding icons should be interpreted as follows:



The electrical warning icon indicates the presence of a hazard which could result in electrical shock.



The warning icon indicates the presence of a hazard which could result in personal injury.



The caution icon indicates important information or warning related to the concept discussed in the text. It might indicate the presence of a hazard which could result in corruption of software or damage to equipment or property.



The information icon alerts the reader to relevant facts and conditions.



The tip icon indicates advice on, for example, how to design your project or how to use a certain function.

Although warning hazards are related to personal injury, and caution hazards are associated with equipment or property damage, it should be understood that operation of damaged equipment could, under certain operational conditions, result in degraded process performance leading to personal injury or death. Therefore, comply fully with all warning and caution notices.

1.6. Terminology

The following is a list of terms that you should be familiar with. The list contains terms that are unique to ABB or have a usage or definition that is different from standard industry usage.

Term	Description
Central unit	Arc Protection Relay REA 101
Extension unit	Arc Protection Module REA 103, REA 105, or REA 107.
IRF relay	A relay with change-over (NO or NC) output contacts. Usually, the NO output gap is used. When no fault is detected in the auxiliary power supply or in the relay, this contact gap is closed.
IRF relay resets	When the self-supervision system of the relay detects a fault in the relay function or in the auxiliary power supply, the contact opens, that is, the IRF relay resets.
Optolink communication	The communication between REA 101 central units.

1.7. Abbreviations

CB	Circuit breaker
CBFP	Circuit breaker failure protection
HSO	High-speed output
IGBT	Insulated gate bipolar transistor
IRF	Internal relay fault
LED	Light-emitting diode
MV	Medium voltage
NC	Normally closed
NO	Normally open
rms	Root-mean square
SG	Switchgroup



1.8. Related documents

Name of the manual	MRS number
Arc Protection Relay REA 10_, Buyer's Guide	1MRS 750929-MBG
Arc Protection Module REA 103, Operator's Manual	1MRS 751004-MUM
Arc Protection Module REA 105, Operator's Manual	1MRS 751005-MUM
Arc Protection Module REA 107, Operator's Manual	1MRS 752135-MUM

1.9. Document revisions

Version	Revision number	Date	History
E	-	-	-New version (F) created
F	-	09.06.2005	-Updated I ₀ information and functionality -Updated figures

2.**Safety**

	National and local electrical safety regulations must always be followed.
	Dangerous voltages can occur on the connectors, even though the auxiliary voltage is disconnected.
	The frame of the device has to be carefully earthed.
	Only a competent electrician is allowed to carry out the electrical installation.
	Sensor fibers have to be handled with care. Sharp bends must be avoided; the minimum allowed bending radius is 50 mm. To avoid stepping on sensor fibers, they should not be placed on the floor unnecessarily during the installation.
	Settings and configuration changes have to be done with the auxiliary supply voltage (U_{aux}) disconnected. Malfunction may occur if changes are made with the supply voltage connected.

3.

Introduction

The REA 10_ arc protection system is designed to give fast trip commands to all circuit breakers (CB) that may feed an arc fault in low voltage or medium voltage air insulated metal-clad switchgears.

In an arc situation, the fault can quickly be localized by inspecting the cover area of the sensor that detected the arc. Two sensor types are available:

- Patented long fiber sensor that detects light along its entire length
- Light collecting lens-type sensors, typically distributed one per each compartment.

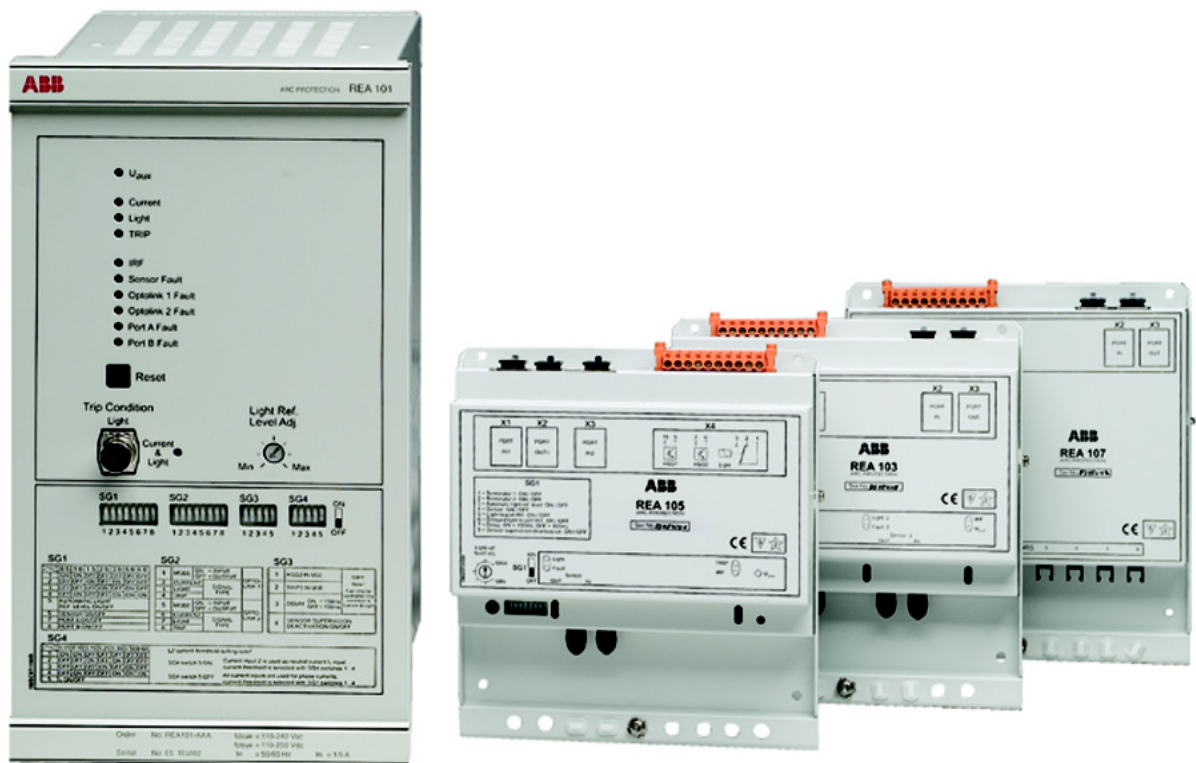

A050514

Fig. 3-1 REA 101 central unit and the REA 10_ extension units

3.1.

Features

- Fast, adjustable three-phase, or two-phase and neutral overcurrent condition to secure tripping
- Wide area automatic or manual backlight compensation
- Loop-type or radial sensor fiber, or lens-type sensors for arc detection
- Two high-speed solid-state (insulated gate bipolar transistor) outputs for tripping of circuit breakers
- One heavy-duty relay output to be used, for example, as circuit breaker failure protection (CBFP) output for an up-stream circuit breaker, or as an alarm output.

- 2 RJ-45 type ports for connecting extension units
- 2 opto-connectors for signal transfer between central units
- Continuous self-supervision of sensor fiber loop, operating voltages and cabling between central units and extension units

3.2.

Use of the REA 101 relay

The central unit REA 101 can operate:

- Independently
- With other REA 101 central units
- With REA 103, REA 105 and REA 107 extension units

REA 101 is provided with 2 extension ports. A maximum of 5 extension units can be daisy-chained to each port. Several REA 101 units can be connected together via optolinks, or via REA 105 units.

By using REA 103, REA 105 and REA 107 you can add selectivity and extend the protection area further. REA 105 is provided with fast trip outputs that are capable of opening, for example, a bus coupler. REA 107 has inputs for 8 lens-type sensors.

4. Connection diagram

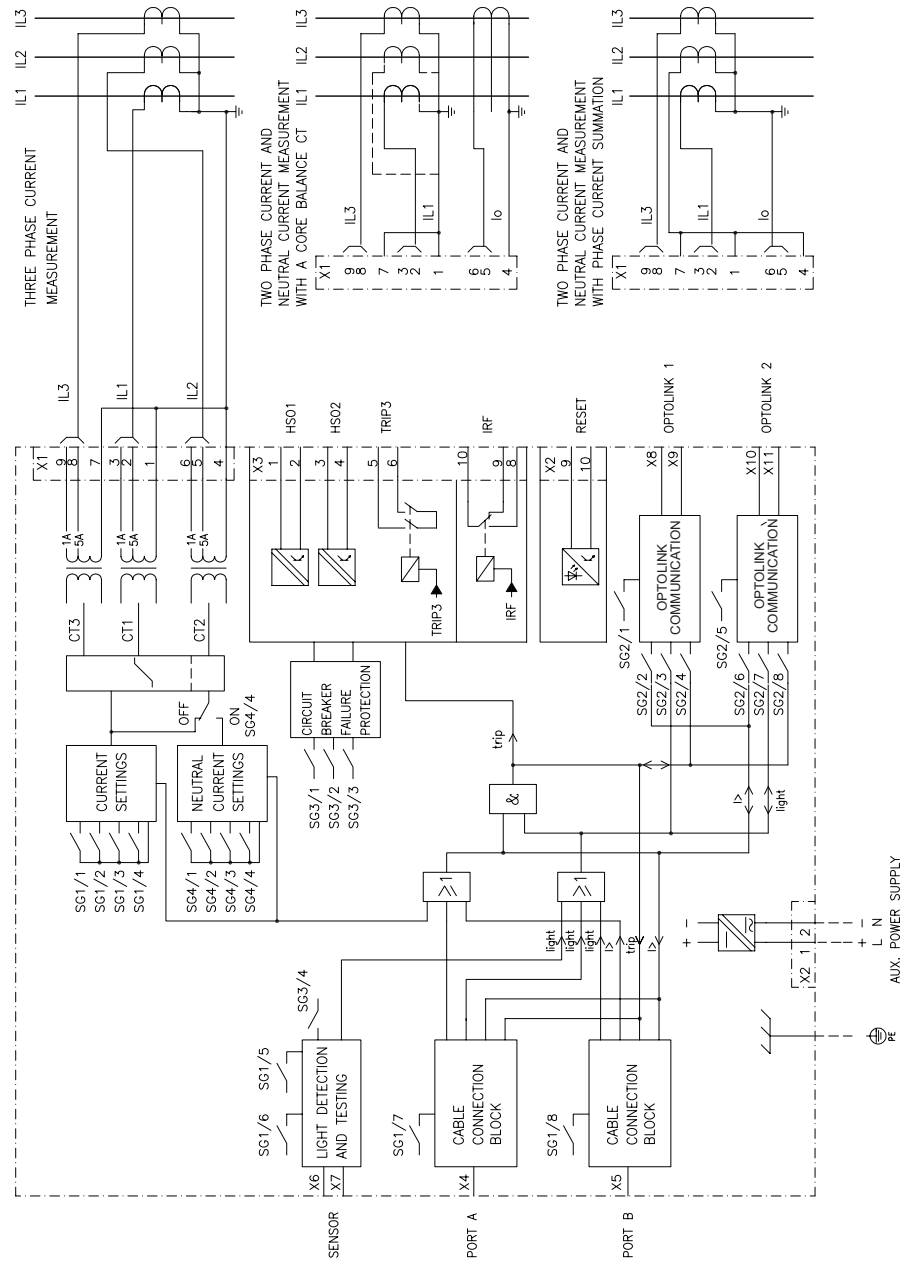

Fig. 4.-1 Connection diagram of REA 101

A050331

5. Operation

5.1. Overcurrent detection unit

- Use the switch SG4/5 (that is, switchgroup SG4, switch 5) to select between three-phase current measurement, or two-phase and neutral current measurement.

Three-phase current measurement

The three-phase currents are measured via transformers. When the current on one phase exceeds the selected reference level, an overcurrent signal is activated.

- Use the switches SG1/1...4 to select the current reference level for the three-phase current inputs. The available current level settings are 0.5, 1.0, 1.5, 2.5, 3.0, 5.0 and 6.0 times the rated current ($I_n = 1.0 \text{ A}$ or 5.0 A).

Two-phase and neutral current measurement

When the current in L1, L3 or L2 (neutral current) exceeds the selected reference level, an overcurrent signal is activated.

- Use the switches SG1/1...4 to select the current reference level for the current inputs L1 and L3. The available current level settings are 0.5, 1.0, 1.5, 2.5, 3.0, 5.0 and 6.0 times the rated current ($I_n = 1.0 \text{ A}$ or 5.0 A).
- Use the switches SG4/1...4 to select the current reference level for the neutral current input L2. The available current level settings are 0.05, 0.1, 0.15, 0.25, 0.3, 0.5 and 0.6 times the rated current ($I_n = 1.0 \text{ A}$ or 5.0 A).

5.2. Light detection unit

The light captured by the sensor is amplified and compared to the pre-selected light reference level. Once the light exceeds the set reference level, a light signal is activated.



An uncovered sensor fiber end is extremely sensitive to light. If radial fiber sensor is used, protect the fiber end from light with a plug to avoid unnecessary triggering.

- Use the switch SG1/6 to activate the arc detection sensor.
- Use the switch SG1/5 to select automatic or manual light reference level.

If you select the automatic reference level, the unit forms the reference level based on the backlight intensity measured by the sensor.

When you select the manual reference level, the unit forms the reference level based on the value you select with the “Light Ref. Level Adj.” potentiometer on the front panel.

The sensor fiber condition is monitored by sending a test pulse through the fiber. If a test pulse is not received at regular intervals at the other end of the fiber loop, the “Sensor Fault” LED and the self-supervision LED “IRF” are activated, and the IRF relay resets.

If the sensor-monitoring feature is not needed, you can deactivate it by using the switch SG3/4.



When the sensor monitoring is deactivated, no test pulse is sent, and a radial (terminated) sensor fiber or lens sensor can be used.

5.3. Sensitivity of sensors

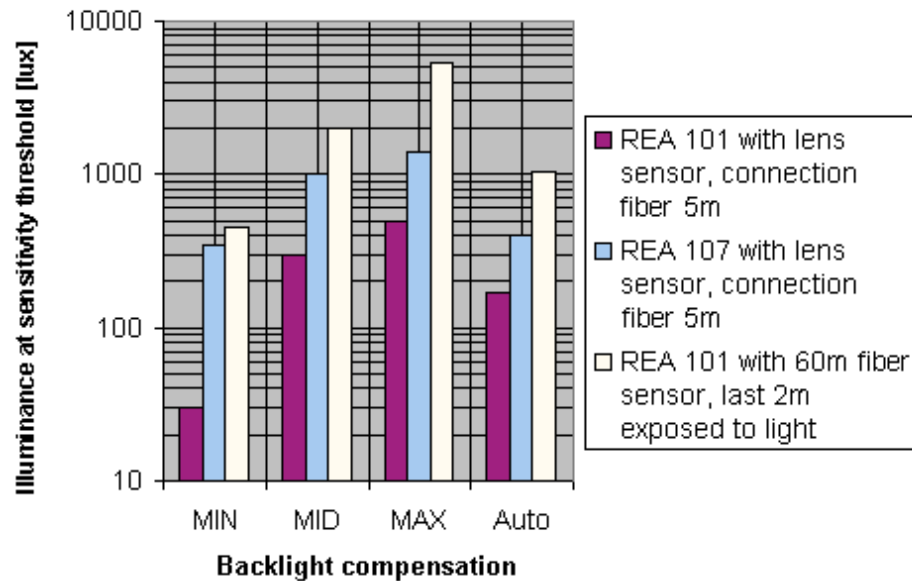

A050616

Fig. 5.3.-1 Sensitivity of REA 10_ sensors at various backlight compensation settings

The intensity of a high-current arc light in a two- or three-phase short circuit can be tens of thousands of luxes. The intensity of a normal office lighting is 200-300 luxes.

The exact determination of the detecting reach of the light sensors is difficult, because the detecting reach depends on several factors:

- Light source energy
- Fiber length
- Reflectances
- Backlight compensation settings

5.3.1. Sensitivity of fiber sensors

The incidence angle of the light is not relevant with fiber sensors.

When an arc protection system is designed, the length of the sensor fiber per one switchgear compartment must be selected according to the possible short-circuit or earth-fault current, and the distance between the sensor and arc. When selecting sensor fiber length, refer to the table below.

Table 5.3.1-1 Minimum length (cm) of the exposed sensor fiber per one switchgear compartment

Fault current (rms)	Distance between sensor and arc			
	100 cm	200 cm	300 cm	400 cm
0.5 kA	20	_a	_a	_a
0.7 kA	20	70	210	280
1.4 kA	20	20	20	140
2.2 kA	20	20	20	20

a. Not operational.

The information in the above table is based on the following reference conditions:

- Copper busbars
- Arc length 10 cm
- Surrounding light ~400 lux
- No reflecting surfaces
- Light reference level is set one scale mark to the right from the minimum

When commissioning the arc protection system, set the light reference level of the device as instructed in Section 8.4. Setting the light reference level.

5.3.2. Sensitivity of lens sensors

The relative sensitivity of the lens sensor from different angles of lightning is presented in Fig. 5.3.2.-1. The normal operating sector is -130° ... $+130^{\circ}$. In practice, light is also reflected from the compartment walls, so the detecting angle is not critical.

The detection distance of a lens sensor is 3 meters. Therefore, when protecting busbar sections, the maximum distance of lens sensors from one another is 6 meters.

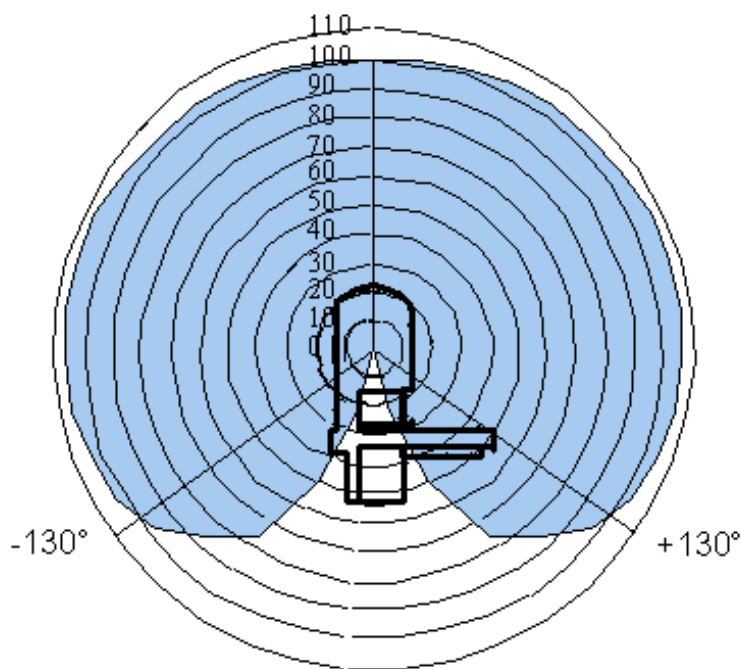

SensitivityAngles

Fig. 5.3.2.-1 Relative sensitivity of the REA lens sensor from different angles of lighting

5.4. Trip output

The trip output is provided with:

- Two high-speed galvanically isolated IGBT semi-conductor outputs, HSO1 and HSO2
- Relay output, TRIP3



The trip outputs can be used in DC and AC circuits.

The control signal of the outputs is activated if the overcurrent signal and the light signal, but not the operating voltage fault signal, are active at the same time.

When the “Trip Condition” key switch on the relay’s front panel is in “Light” position, the overcurrent signal is constantly active, and tripping is activated by an arc alone. When a trip signal is delivered, the trip outputs are latched in active state. You can reset the outputs either by pushing the “Reset” button on the relay’s front panel, or by using a reset signal applied to RESET input.

5.5. Ports A and B for connecting extension units

- Use the switches SG1/7...8 to activate the ports A and B.

The extension units are connected to the ports A and B by using connection cables. The extension unit receives its operating voltage and operation signals over the port.

The ports are protected against short-circuit and cable breaks. If the connection cable from a port breaks, the concerned chain is disconnected, and the fault LED (“Port A Fault” or “Port B Fault”) as well as the “IRF” LED on the central unit are lit, and the IRF relay resets.

A maximum of 5 extension units can be connected to one port. If an extension unit included in the chain connected to the port is damaged, the fault LED of the port starts flashing, the “IRF” LED is lit and the IRF relay resets.

5.6.

Optolink communication

The REA 101 relay contains two communication links: Optolink 1 and Optolink 2.

- Use the switches SG2/1...8 to select the links to be used, and the messages to be communicated between them.



Each link can be programmed either as a transmitter or as a receiver.

The purpose of the communication link is to communicate ON/OFF type messages between the central units over the signal transfer fiber. The message can be:

- Light signal
- Overcurrent signal
- Trip signal

Only one type of message per optolink can be transmitted between the central units. The data to be communicated depends on the system design.

To monitor the connection, a test pulse is sent through the signal transfer fiber at regular intervals. If the test pulse is not received at the specified time, the optolink fault LED (“Optolink 1 Fault” or “Optolink 2 Fault”) and the “IRF” LED of the central unit is lit, and the IRF relay resets.

5.7.

Circuit-breaker failure protection



The circuit-breaker failure protection (CBFP) is enabled, when the Trip Condition key switch is in “Current&Light” position.

The circuit-breaker failure protection is implemented by delaying either the HSO2 output or the TRIP3 output, or when required, both the outputs. Note that if both the outputs are used, the delay time is the same, but the pick-up time of the relay (5...15 ms) is added to the TRIP3 relay.

- Use the switches SG3/1...3 to select the wanted alternative.

The selected delay time, 100 ms or 150 ms, starts running once the HSO1 is activated. Delayed tripping does not take place if the overcurrent signal disappears before the specified time delay elapses.

When the circuit-breaker failure protection is not in use, all the trip outputs operate in parallel.

5.8. Self-supervision unit

In addition to that mentioned in the above sections, the self-supervision unit (IRF) monitors the operating voltage of the relay. If a fault is detected in the operating voltages, the self-supervision unit prevents the relay from operating. In addition, the "IRF" LED of the central unit is lit, and the IRF relay resets.

The self-supervision signal output operates on the closed circuit principle as presented in the figure below. Under normal conditions, the output relay is energized and the contact gap between 8 and 10 is closed. If the auxiliary power supply fails, or an internal fault is detected, the contact gap between 8 and 10 is opened.

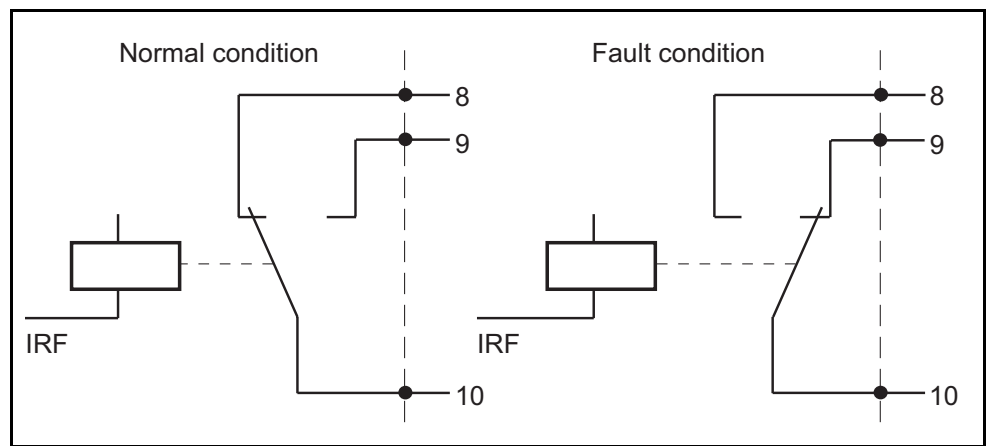

A050349

Fig. 5.8.-1 Self-supervision output (IRF)

5.9. Front panel

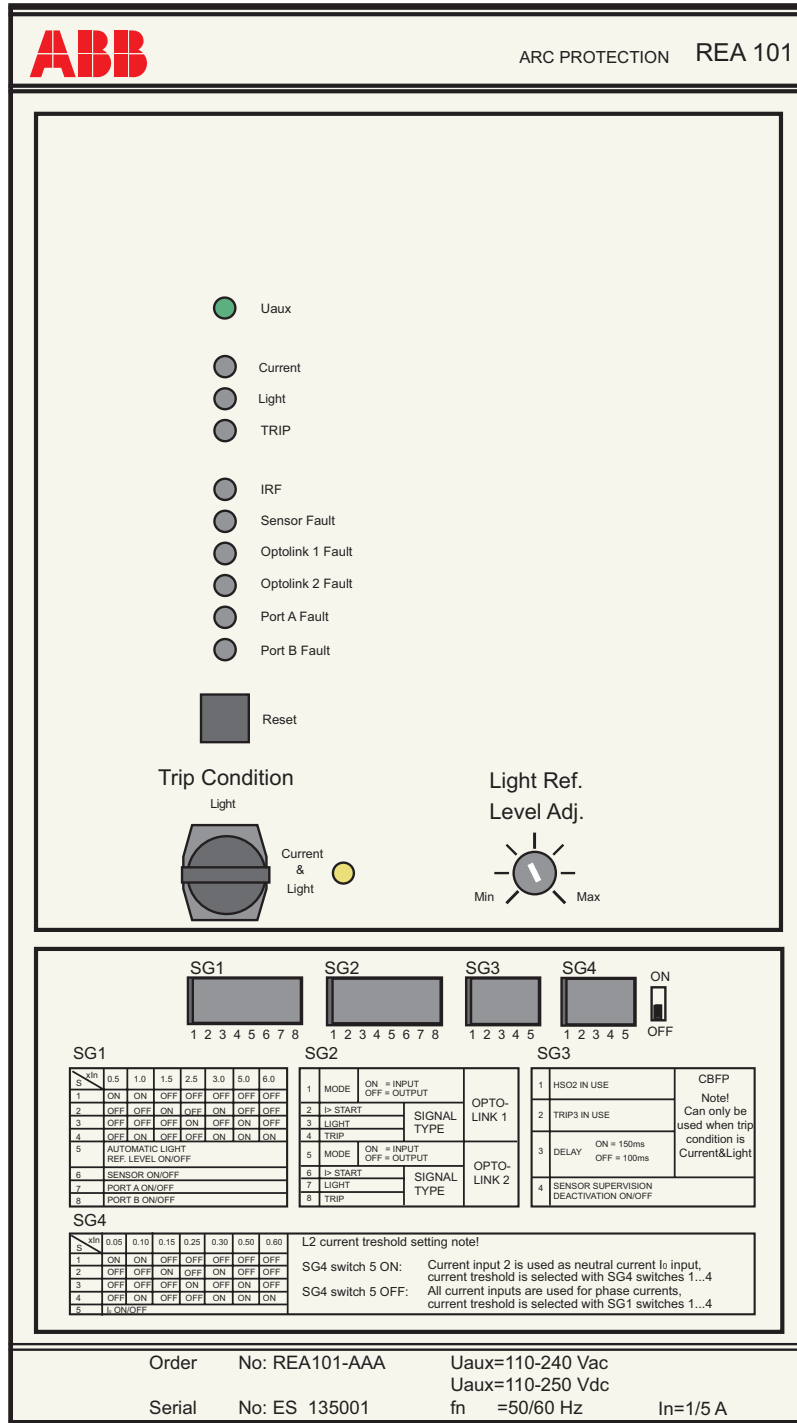

Fig. 5.9.-1 REA 101 front panel

A050326

5.10. Functions of LEDs, push-buttons and switches

Table 5.10.-1 REA 101 LEDs

LED	Indication when the LED is lit
U _{aux}	The power supply to the central unit is connected.
Current	The overcurrent signal of the central unit is active when: <ul style="list-style-type: none"> • Either the measured current exceeds the set overcurrent or neutral current threshold, or the overcurrent condition has been eliminated ("Trip Condition" key switch in position "Light"). • The overcurrent signal may also originate in another central unit and be received via a REA 105 unit or an optolink connection.
Light	The sensor fiber of the central unit has detected light.
TRIP	The central unit has tripped.
IRF	The self-supervision system of the central unit has detected an internal relay fault, the IRF relay has also reset. <ul style="list-style-type: none"> • Fault in operating voltage: only the "IRF" fault LED is lit and, the operation of the central unit is prevented. • Other fault situations: the "IRF" LED and the other fault LEDs are lit. • The "IRF" LED of the central unit is also lit when the "IRF" LED of an extension unit is lit. In addition, the fault LED of the port is flashing.
Sensor Fault + IRF	<ul style="list-style-type: none"> • A breakage in the sensor fiber connected to the central unit. (The sensor fiber may still detect light between the sensor input and the breakage.) • Fault in transmitter or receiver.
Optolink 1 Fault + IRF	A fault in the signal transfer fiber connected to the Input port of Optolink 1. An optolink fault does not prevent the operation of the central unit.
Optolink 2 Fault + IRF	A fault in the signal transfer fiber connected to the Input port of Optolink 2. An optolink fault does not prevent the operation of the central unit.
Port A Fault + IRF	<ul style="list-style-type: none"> • Steady light: fault in port A or in the connection cable (bus) connected to it. A port fault does not prevent the operation of the central unit. • Flashing: fault in the extension unit connected to the port A. The "IRF" LED light of the central unit is steady.
Port B Fault + IRF	Same operation principle as for port A, see above.

5.10.1. "Reset" push-button

Resetting of LED indicators of the central unit and the extension units connected to the central unit, semi-conductor outputs and output relays; operation in parallel with binary input (RESET X2/9-10).

5.10.2. “Trip Condition” key switch with “Current&Light” LED



The “Trip Condition” key switch must always be in an extreme position.

When the “Trip Condition” key switch is in the “Current&Light” position, and the “Current&Light” LED is lit (normal operation), the overcurrent condition level is in use. Thereby both overcurrent and light are required for tripping.

- Take the overcurrent condition level into use (overcurrent and light required for tripping) by using the switches SG1/1...4 (L1, L2, L3 inputs), or SG1/1...4 (L1, L3), and SG4/1...5 (L2).

When the key switch is in the “Light” position and the “Current” LED is lit, the overcurrent condition level is not in use. Thereby only light is required for tripping. This option can be used, for example, during service.

5.10.3. “Light Ref. Level Adj.” potentiometer

A potentiometer for manual backlight compensation:

- Switch SG1/5 is in OFF position:
the “Light Ref. Level Adj.” potentiometer is in use.

5.10.4. Switchgroup SG1

- Switch 1 is in ON position:
the current threshold is $0.5 \times I_n$ (the switches 2, 3 and 4 are in OFF position).
- Switch 2 is in ON position:
the current threshold is $1.5 \times I_n$ (the switches 1, 3 and 4 are in OFF position).
- Switch 3 is in ON position:
the current threshold is $2.5 \times I_n$ (the switches 1, 2 and 4 are in OFF position).



Only one of the switches 1...3 can be in ON position at a time.

If the switches 1-4 of switchgroup SG1 all are set into position "0", the trip current will be $3.0 \times I_n$.

- Switch 4:
 - Switch 4 is in ON position and one of the switches 1...3 is in ON position:
the selected current threshold is doubled.
 - Switch 4 is in ON position and the switches 1...3 are in OFF position:
the current threshold is $6.0 \times I_n$.
- Switch 5 (the automatic light reference level is ON/OFF):
 - Switch 5 is in ON position:
the automatic backlight compensation is selected (the “Light Ref. Level Adj.” potentiometer is not in use).
 - Switch 5 is in OFF position:
the manual backlight compensation is selected (the “Light Ref. Level Adj.” potentiometer is in use).

- Switch 6 (Sensor ON/OFF) is in ON position:
the sensor fiber of the central unit is used for arc detection.
- Switch 7 (port A ON/OFF) is in ON position:
the port A is in use.
- Switch 8 (port B ON/OFF) is in ON position:
the port B is in use.

5.10.5.

Switchgroup SG2 (optolink communication)

Optolink 1, SG2/1...4

- Switch 1 (Mode ON=Input, OFF=Output):
 - Switch 1 is in ON position:
the Optolink 1 Input port operates as signal input.
 - Switch 1 is in OFF position:
the Optolink 1 Output port operates as signal output.
- Switch 2 (Current):
 - Switch 2 is in ON position:
the overcurrent signal is either received or transmitted, depending on the setting of the switch 1.
 - Switch 2 is in OFF position:
no overcurrent signal is transmitted or received.
- Switch 3 (Light):
 - Switch 3 is in ON position:
the light signal is either received or transmitted, depending on the setting of switch 1.
 - Switch 3 is in OFF position:
no light signal is transmitted or received.
- Switch 4 (Trip):
 - Switch 4 is in ON position:
the trip signal is either received or transmitted, depending on the setting of switch 1.
 - Switch 4 is in OFF position:
no trip signal is transmitted or received.



Only one of the switches 2...4 is allowed to be in ON position at a time.

Optolink 2, SG2/5...8

- Switch 5 (Mode ON=Input, OFF=Output):
 - Switch 5 is in ON position:
the Optolink 2 Input port operates as signal input.
 - Switch 5 is in OFF position:
the Optolink 2 Output port operates as signal output.
- Switch 6 (Current):

Operator's Manual

- Switch 6 is in ON position:
the overcurrent signal is either received or transmitted, depending on the setting of the switch 5.
- Switch 6 is in OFF position:
no overcurrent signal is transmitted or received.
- Switch 7 (Light):
 - Switch 7 is in ON position:
the light signal is either received or transmitted, depending on the setting of the switch 5.
 - Switch 7 is in OFF position:
no light signal is transmitted or received.
- Switch 8 (Trip):
 - Switch 8 is in ON position:
the trip signal is either received or transmitted, depending on the setting of the switch 5.
 - Switch 8 is in OFF position:
no trip signal is transmitted or received.



Only one of the switches 6...8 is allowed to be in ON position at a time.

5.10.6.**Switchgroup SG3 (circuit-breaker failure protection)**

When the circuit-breaker failure protection (CBFP, SG3/1...3) is in use:

1. No delayed tripping occurs in a trip situation, if the overcurrent signal disappears during the set delay time.
 2. Delayed tripping always occurs in a trip situation when the overcurrent condition is not in use (the “Trip Condition” key switch is in position “Light”, and the “Current” LED is lit).
- Switch 1 (HSO2 in use):
 - Switch 1 is in ON position:
the circuit-breaker failure protection is in use. HSO2 operates after the time specified by the switch 3 has elapsed, provided that the overcurrent signal is still active. The time starts running when HSO1 operates.
 - Switch 1 is in OFF position:
the circuit-breaker failure protection is not in use and HSO2 operates at the same time as HSO1.
 - Switch 2 (Trip3 in use):
 - Switch 2 is in ON position:
the circuit-breaker failure protection is in use. Trip3 operates after the time specified by switch 3 has elapsed, provided that the overcurrent signal is still active. The time starts running when HSO1 operates.
 - Switch 2 is in OFF position:
the circuit-breaker failure protection is not in use and Trip3 operates at the same time as HSO1 (added with output relay pick-up time).

- Switch 3 (Delay ON=150 ms, OFF=100 ms):



The switch 3 is in use only when the circuit-breaker failure protection is in use.

- Switch 3 is in ON position:
the output selected with switch 1 and/or 2 operates 150 ms after the operation of HSO1, provided that the overcurrent signal is still active.
- Switch 3 is in OFF position:
the output selected with switch 1 and/or 2 operates 100 ms after the operation of HSO1, provided that the overcurrent signal is still active.
- Switch 4 (Sensor supervision deactivation ON/OFF):
 - Switch 4 is in ON position:
sensor fiber condition monitoring is not in use. A radial sensor fiber can be used.
 - Switch 4 is in OFF position:
sensor fiber condition monitoring is in use. A sensor fiber loop can be used.
- Switch 5 has no function.

5.10.7.

Switchgroup SG4

- Switch 1 is in ON position:
current threshold $0.05 \times I_n$ (the switches 2, 3, and 4 are in OFF position).
- Switch 2 is in ON position:
current threshold $0.15 \times I_n$ (the switches 1, 3, and 4 are in OFF position).
- Switch 3 is in ON position:
current threshold $0.25 \times I_n$ (the switches 1, 2, and 4 are in OFF position).



Only one of the switches 1-3 can be in the ON position at a time.

If the switches 1-4 of switchgroup SG4 all are set into position "0", the trip current will be $0.3 \times I_n$.

- Switch 4:
 - Switch 4 is in ON position and one of the switches 1...3 is in ON position:
the selected current threshold is doubled.
 - Switch 4 is in ON position and the switches 1...3 are in OFF position:
current threshold $0.6 \times I_n$.
- Switch 5:
 - Switch 5 is in ON position:
the current input 2 is used as a neutral current I_0 input. The current threshold is selected with the switch SG4/1...4.
 - Switch 5 is in OFF position:
all the current inputs are used for phase currents. The current threshold is selected with the switch SG1/1...4.

6. Rear panel

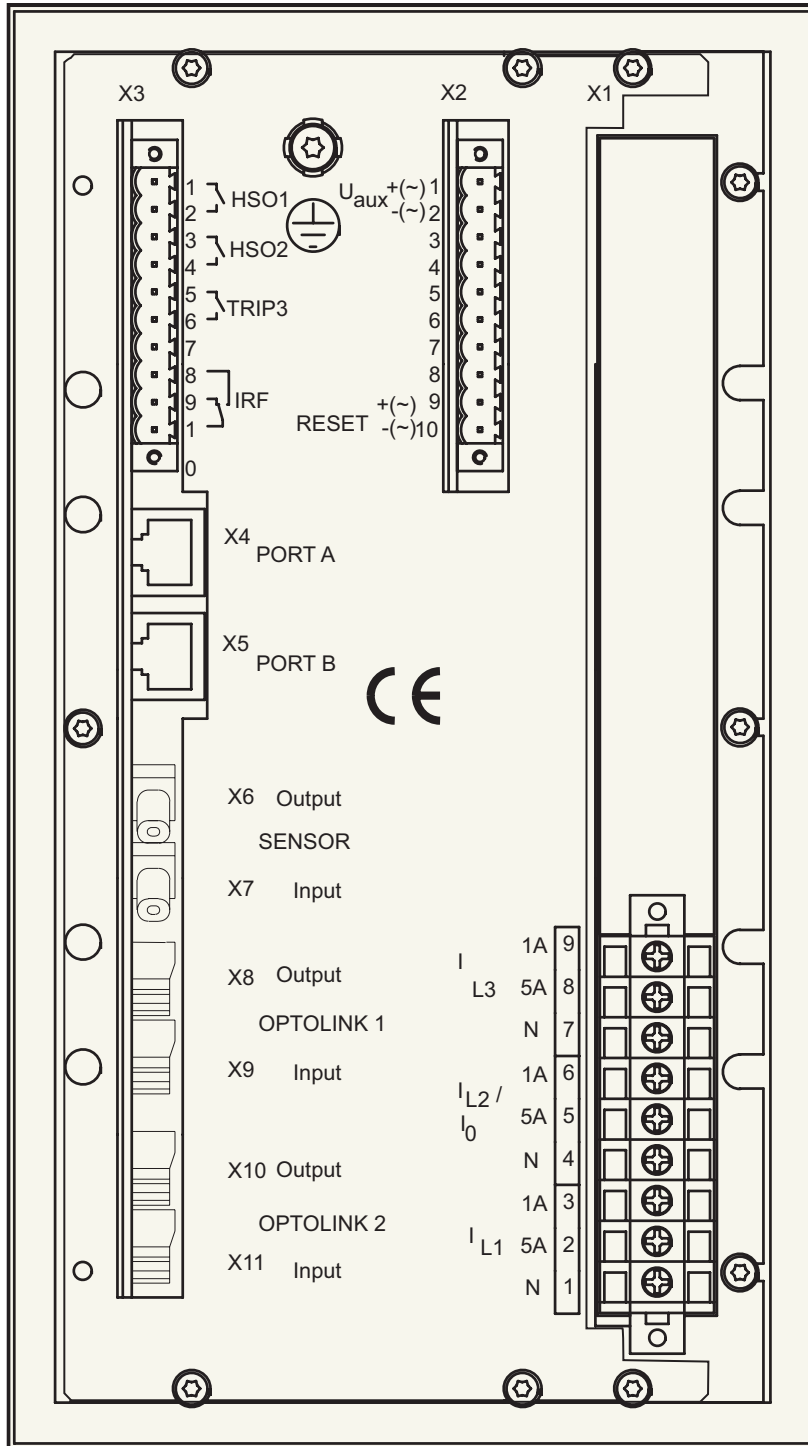

A050332

Fig. 6.-1 Terminals in REA 101 rear panel

7. Connections

7.1. Connector X1

Current transformer connections:

- 1 I_{L1} Common
- 2 $I_{L1\ 5A}$ In = 5 A
- 3 $I_{L1\ 1A}$ In = 1 A
- 4 I_{L2} Common
- 5 $I_{L2/10\ 5A}$ In = 5 A
- 6 $I_{L2/10\ 1A}$ In = 1 A
- 7 I_{L3} Common
- 8 $I_{L3\ 5A}$ In = 5 A
- 9 $I_{L3\ 1A}$ In = 1 A

7.2. Connector X2

Auxiliary voltage and RESET terminal:

- 1 U_{aux} +(~) Auxiliary voltage +(~)
- 2 U_{aux} -(~) Auxiliary voltage -(~)
- 3 Not in use
- 4 Not in use
- 5 Not in use
- 6 Not in use
- 7 Not in use
- 8 Not in use
- 9 RESET +(~) Reset input: indications, outputs
- 10 RESET -(~) Reset input: indications, outputs

7.3. Connector X3

I/O terminal:

- 1 HSO1 +(~) Heavy-duty high-speed semi-conductor output 1
- 2 HSO1 -(~) Heavy-duty high-speed semi-conductor output 1
- 3 HSO2 +(~) Heavy-duty high-speed semi-conductor output 2
- 4 HSO2 -(~) Heavy-duty high-speed semi-conductor output 2
- 5 TRIP3 +(~) Heavy-duty relay output
- 6 TRIP3 -(~) Heavy-duty relay output
- 7 Not in use
- 8 IRF/NO Self-supervision alarm relay/normal open contact
- 9 IRF/NC Self-supervision alarm relay/normal closed contact
- 10 IRF common Self-supervision alarm relay/common contact

7.4. Connectors X4 and X5

Extension unit connection ports:

X4 PORT A

X5 PORT B

7.5. Connectors X6 and X7

Sensor fiber connectors:

X6 Output

X7 Input

7.6. Connectors X8 and X9

Signal transfer fiber connectors of OPTOLINK 1:

X8 Output

X9 Input

7.7. Connectors X10 and X11

Signal transfer fiber connectors of OPTOLINK 2:

X10 Output

X11 Input

8. Commissioning

8.1. Checking the voltages



All the checks and switch settings have to be made before the auxiliary voltage supply of the unit is connected.

1. Check the auxiliary voltage:

Check the supply voltage range (U_{aux}) of the supply unit. The voltage range is marked on the marking strip that can be found on the underpart of the REA 101 front plate. See also Chapter 11. Technical data.

2. Control the voltage of the RESET input:

Check the voltage range of the RESET input if the input is used for resetting. The rated voltages and voltage ranges are specified in Chapter 11. Technical data.

8.2. Setting the relay

1. Program the switchgroups SG1, SG2, SG3 and SG4.

The default settings of the switchgroups are:

SG1	00000000
SG2	00000000
SG3	00000
SG4	00000

2. Set the switches of the programming switchgroups SG1, SG2, SG3 and SG4 as required by the application.

The switchgroups are presented in Section 5.10. Functions of LEDs, push-buttons and switches. For application examples, refer to Chapter 10. Application examples.

3. Set the “Light Ref.Level Adj.” potentiometer. As a default, the potentiometer is in the middle position.



If the automatic backlight compensation has been selected (switch SG1/5 is in ON position), you do not have to change the setting of the potentiometer.

4. Set the “Trip Condition” key switch.

The default position of the key switch is “Current&Light”.

8.3. Testing the arc protection system

When testing the arc protection system:

1. Check the current measurement function by measuring the primary or secondary circuit. When the current threshold is exceeded, the “Current” LED of the concerned REA 101 relay is lit. Each REA 101 relay is submitted to this measurement.
2. Turn the “Trip Condition” key switch into “Light” position to check that the overcurrent data is transmitted through the entire system arrangement as required by the application.
3. Check that the “Current” LED of the concerned REA 101 unit is lit.
4. Finally, turn the “Trip Condition” key switch into “Current&Light” position.
5. Check each REA 101 relay included in the application in the same way.

8.4. Setting the light reference level

1. Set the lighting level of the environment as close to normal work conditions as possible.
2. Turn the “Light Ref. Level Adj.” potentiometer until the “Light” LED is lit, or goes off.
3. Turn the potentiometer one scale mark to the right.



If the “Light” LED stays off even though the potentiometer is in the “Min.” position, you can either leave the potentiometer in this position or turn it one or several scale marks to the right, depending on the wanted sensitivity level.

4. Turn the “Trip Condition” key switch into “Light” position.



The “Trip Condition” key switch must always be in an extreme position.

5. Expose one sensor at a time to light by using, for example, a flash, and check that the right circuit breakers operate.



The flash duration should be at least 1 ms. Note that the integrated flashes of pocket cameras are normally not powerful enough. Using separate flash units with fresh batteries (guide nr 20 or more) is recommended.

6. When all the sensors are tested, set the “Trip Condition” key switch of the REA 101 relay(s) as required by the application.

9. Dimension drawings

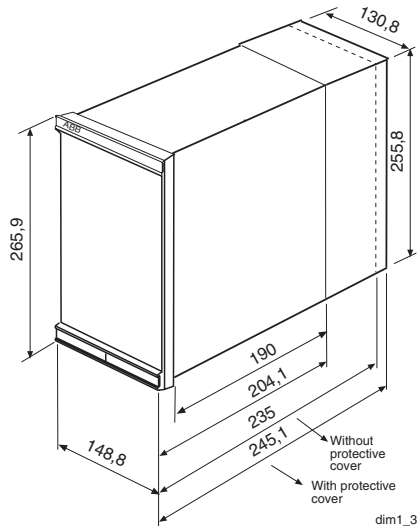
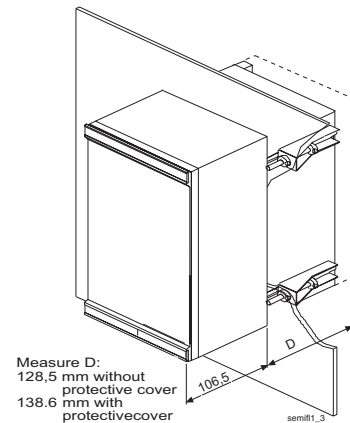
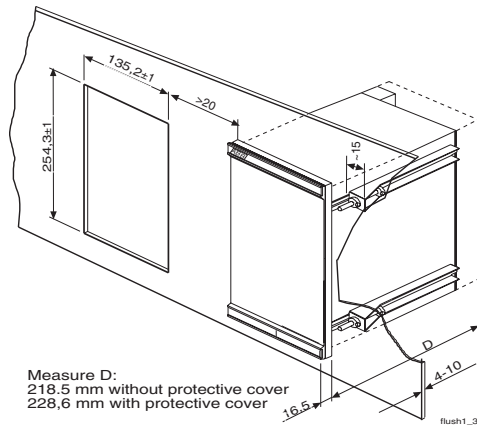

Fig. 9.-1 REA 101 dimensions

9.1. Mounting alternatives



- Flush mounting kit 1MRS050209
- Semi-flush mounting kit 1MRS050254

Fig. 9.1.-1 Flush mounting and semi-flush mounting

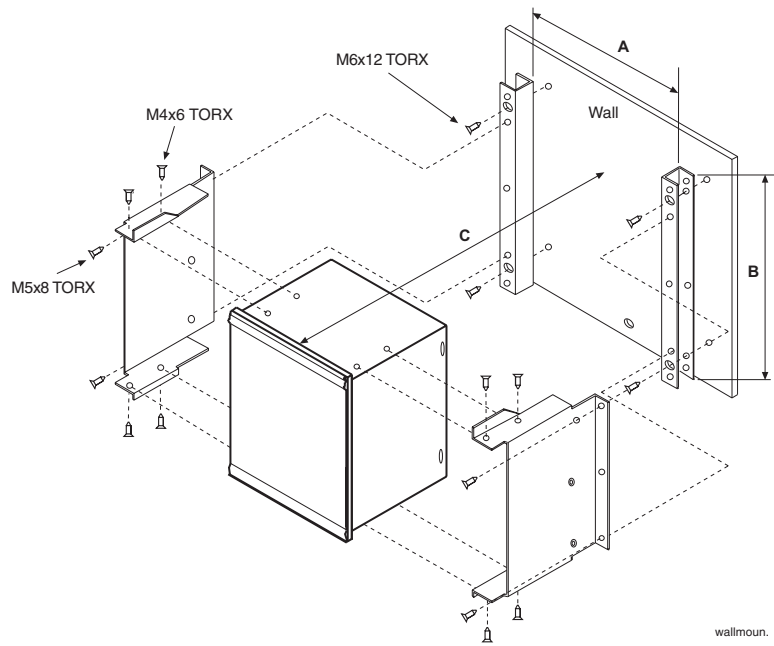

Surface mounting kit 1MRS050240

Fig. 9.1.-2 Surface mounting

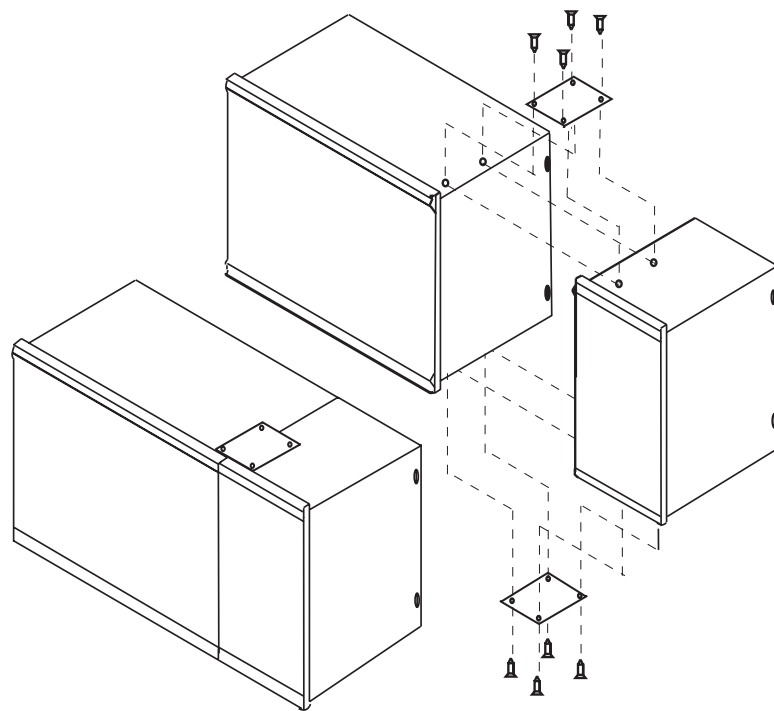

Mounting kit 1MRS050241

Fig. 9.1.-3 Connecting cases together

A050198

Operator's Manual

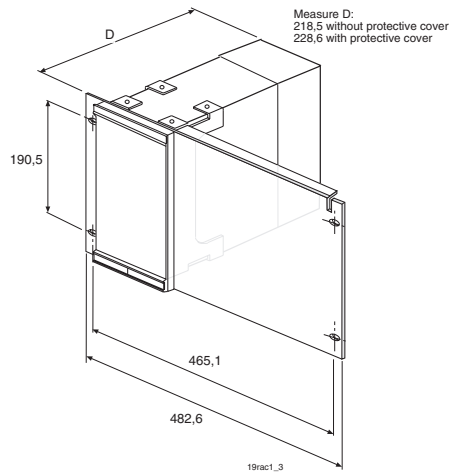

19" mounting kit

1MRS050258

Fig. 9.1.-4 19" rack mounting, a single REA 101 unit

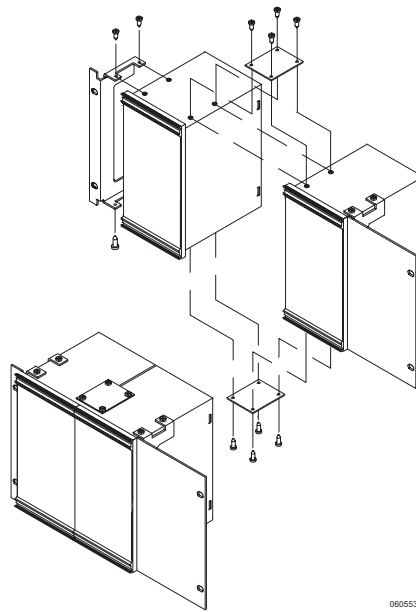

19" mounting kits

1MRS050241

1MRS050377

Fig. 9.1.-5 19" rack mounting, two REA 101 units

10. Application examples

10.1. Remember when constructing applications

- Do not change connections or set any switches when the supply voltage is connected to the units.
- Condition monitoring of a radial sensor fiber is not possible. When commissioning a radial sensor fiber, remember to set the SG3/4 switch in position ON.
- Check the switches of the ports, when adding or removing extension units. Remember that the maximum number of extension units to be linked to one port is five, that is, ten extension units at the maximum can be connected to one REA 101 relay. Check that the terminal resistor of the last extension unit of either port is switched in the ON position (SG1/1).
- When the circuit-breaker failure protection is used, it should be noted that the delay of the circuit-breaker failure protection is controlled by the overcurrent signal. Should the first trip be successful and the overcurrent disappear before the delay time runs out, no delayed tripping will occur. If the overcurrent situation lasts throughout the delay time, a delayed trip signal will be delivered. The “Trip Condition” key switch can be used to activate an overcurrent signal. Then the delayed trip function always operates in a trip situation, provided the circuit-breaker failure protection is in use.
- Overcurrent information between two REA 101 central units has to be transmitted either over OPTOLINK connections and the signal transfer fiber, or over the connection cable of the extension units and the REA 105 unit, but not via both at the same time.



When the REA 10_ units in the same arc protection system are located in separate switchgears, the connection between the REA 10_ units must be made by using optolink, unless it can be ensured that the switchgears are in the same potential in all conditions.

- When the central unit REA 101 performs tripping, it simultaneously delivers a trip command to the REA 105 extension units connected to it.

10.2. Application examples

The switch settings of the examples: 0 = OFF and 1 = ON.

Example 1

The arc protection is implemented by using REA 101.

The arc sensor loop of the relay passes through all the spaces that are to be protected. Tripping requires a light signal generated by an arc, and an overcurrent signal caused by a fault current. Current is measured three-phase as 5 A or 1 A secondary current. When an arc occurs, the Q2 circuit breaker is operated via the semiconductor output HSO1.

In alternative 2, the semi-conductor output HSO2 is used as a circuit-breaker failure protection output. If the feeder circuit breaker Q2 for some reason is unable to break the fault current within 100 ms after the trip operation, the circuit breaker Q1 on the transformer primary side is opened via output HSO2.

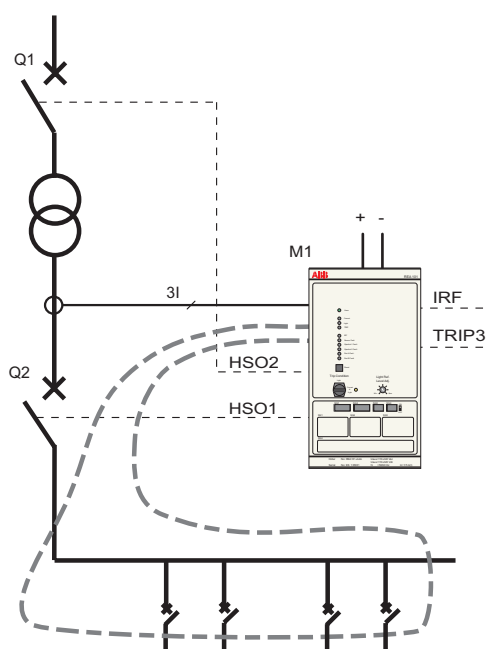

A050516

Fig. 10.2.-1 Example 1

Settings of central unit M1:

- Alternative 1:

SG1 = 1001 0100 SG2 = 0000 0000 SG3 = 00000 SG4 = 00000

HSO2 is not used as CBFP, that is, HSO2 operates at the same time as HSO1.

- Alternative 2:

SG1 = 1001 0100 SG2 = 0000 0000 SG3 = 10000 SG4 = 00000

HSO2 is used as CBFP, time delay 100 ms.

Example 2

This application is similar to the example 1, with the exception that the terminal end of the arc sensor fiber has not been brought back to the arc protection relay. However, the loop arrangement where both ends of the sensor fiber are connected to the relay is preferred, because this radial arrangement does not allow monitoring of the sensor fiber. The condition monitoring feature has to be deactivated (switch SG3/4).

A radial sensor fiber is always connected to terminal X7 (Sensor Input).



An uncovered sensor fiber end is extremely sensitive to light. To avoid unnecessary triggering, protect the fiber end from light with a plug.

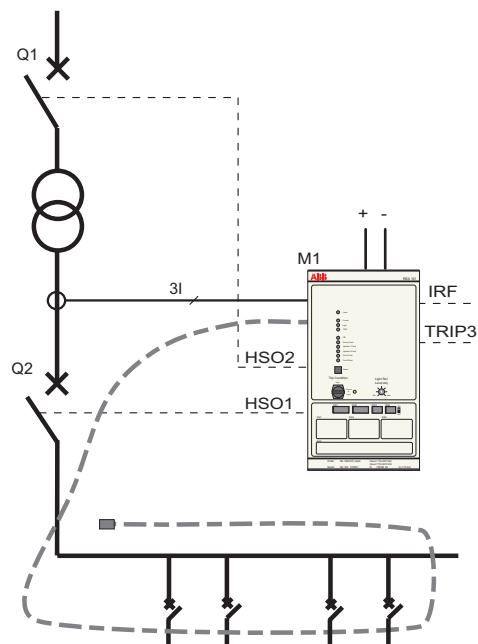

A050517

Fig. 10.2.-2 Example 2

Settings of central unit M1:

- Alternative 1:

SG1 = 1001 0100 SG2 = 0000 0000 SG3 = 00010 SG4 = 00000

HSO2 is not used as CBFP, that is, HSO2 operates at the same time as HSO1.

- Alternative 2:

SG1 = 1001 0100 SG2 = 0000 0000 SG3 = 10010 SG4 = 00000

HSO2 is used as CBFP, time delay 100 ms

Example 3

In this example, the number of arc sensor loops has been increased to five by adding two REA 103 extension units, which have been linked to the chain connected to port A via connection cables.

Tripping is activated in the same way as in the examples 1 and 2. Information about the loop that detected the arc is obtained via the alarm relay outputs Light1 and Light2 of the REA 103 extension units. As the extension unit S2 is the last one in the chain connected to port A, the connection cable has to be terminated here by connecting the terminators (programming switch SG1/1 = ON).

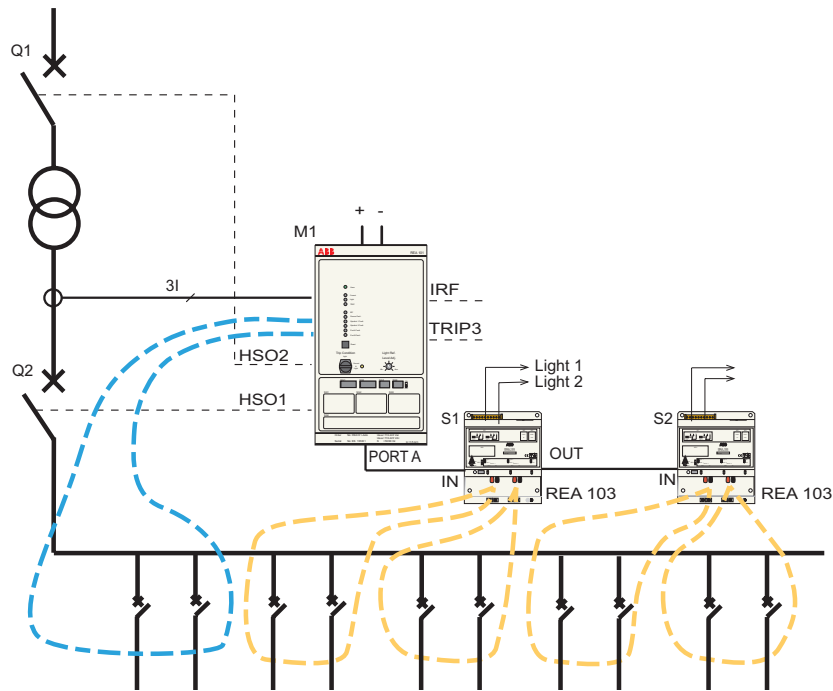

A050518

Fig. 10.2.-3 Example 3

Settings of central unit M1:

- Alternative 1:

SG1 = 1001 0110 SG2 = 0000 0000 SG3 = 00000 SG4 = 00000

HSO2 is not used as CBFP, that is, HSO2 operates at the same time as HSO1.

- Alternative 2:

SG1 = 1001 0110 SG2 = 0000 0000 SG3 = 10100 SG4 = 00000

HSO2 is used as CBFP, time delay 150 ms

Settings of extension unit S1: SG1 = 01110

Settings of extension unit S2: SG1 = 11110

The extension unit S2 is the last one in the chain, which means that the connection cable has to be terminated here (SG1/1=ON).

Example 4

In this application, the circuit breaker compartments of outgoing feeders and cable terminations are protected by the sensors of the REA 107. The busbar is protected by the sensor loop of the REA 101. After tripping, the Light LED of the REA 101 or the REA 107 indicates where the fault has occurred.

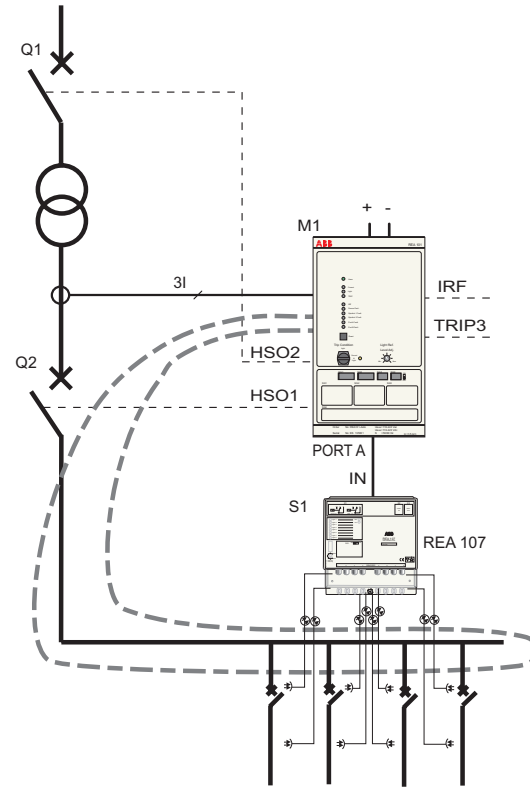

A050519

Fig. 10.2.-4 Example 4

Settings of the central unit M1:

- Alternative 1:

SG1 = 1001 0110 SG2 = 0000 0000 SG3 = 00000 SG4 = 00000

HSO2 is not used as CBFP, that is, HSO2 operates at the same time as HSO1.

- Alternative 2:

SG1 = 1001 0110 SG2 = 0000 0000 SG3 = 10000 SG4 = 00000

HSO2 is used as CBFP, time delay 100 ms.

Settings of the extension unit S1:

SG1 = 1011 1111

Example 5

In this application, the circuit breaker compartments of outgoing feeders, cable terminations and bus bar compartment are protected by the lens sensors of the REA 107.

The incoming circuit breaker is protected by the lens sensor of the REA 101. After tripping, the Light LED of the REA 101 or the REA 107 indicates where the fault has occurred.

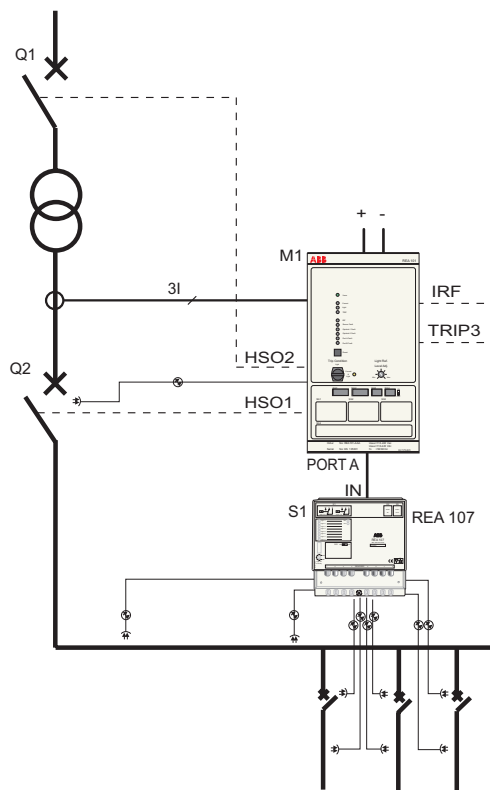

A050520

Fig. 10.2.-5 Example 5

Settings of the central unit M1:

SG1 = 1001 0110 SG2 = 0000 0000 SG3 = 00010 SG4 = 00000

HSO2 is not used as CBFP, that is, HSO2 operates at the same time as HSO1.

Settings of the extension unit S1:

SG1 = 1011 1111

Example 6

In this example, two REA 105 extension units with trip outputs are connected to port A of the central unit.

If an arc occurs, for example, in the area monitored by the extension unit S3, the circuit breaker Q3 is the only one to be opened. Thereby selective tripping is obtained, and the healthy part of the system remains live. If the circuit-breaker

failure protection (CBFP) of the REA 105 extension unit is in use, and the opening of circuit breakers Q3 or Q4 does not eliminate the fault current during the time delay (150 ms), the central unit REA 101 will open the circuit breaker Q2. Correspondingly, if the circuit-breaker failure protection of the central unit is also in use, and the fault current does not disappear during the time delay following the opening of the circuit breaker Q2, the central unit will open the circuit breaker Q1.



When the central unit REA 101 trips, it simultaneously delivers a trip command to the REA 105 extension units connected to it.

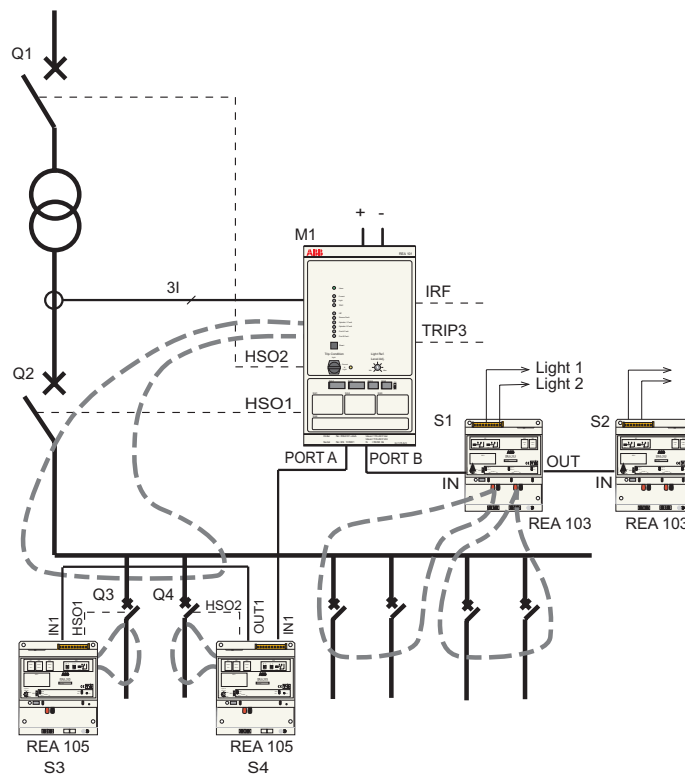

A050521

Fig. 10.2.-6 Example 6

Settings of central unit M1:

- Alternative 1:

SG1 = 1001 0111 SG2 = 0000 0000 SG3 = 00000 SG4 = 00000

HSO2 is not used as CBFP, that is, HSO2 operates at the same time as HSO1.

- Alternative 2:

SG1 = 1001 0111 SG2 = 0000 0000 SG3 = 10100 SG4 = 00000

HSO2 is used as CBFP, time delay 150 ms.

Settings of extension unit S1: SG1 = 01110

Settings of extension unit S2: SG1 = 11110

Settings of extension unit S3: CBFP not in use: SG1 = 1011 0000

Settings of extension unit S4: CBFP not in use: SG1 = 0011 0000

Circuit-breaker failure protection, with 150 ms delay, used in extension units S3 and S4:

S3: SG1 = 1011 0110

S4: SG1 = 0011 0110

Example 7

The operation of this application is similar to the application in the example 6. The only difference between these applications is the devices used.

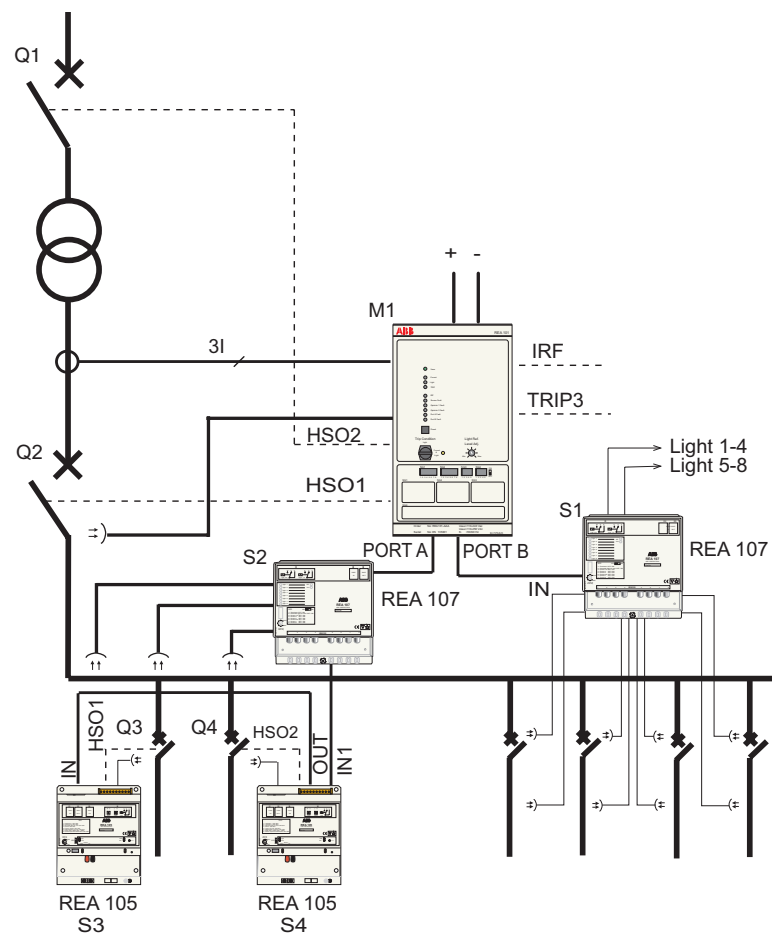

A050330

Fig. 10.2.-7 Example 7

Settings of central unit M1:

- Alternative 1:

SG1 = 1001 0110 SG2 = 0000 0000 SG3 = 00010 SG4 = 00000

Operator's Manual

HSO2 is not used as CBFP, that is, HSO2 operates at the same time as HSO1.

- Alternative 2:

SG1 = 1001 0110 SG2 = 0000 0000 SG3 = 10110 SG4 = 00000

HSO2 is used as CBFP, time delay 150 ms.

Settings of the extension unit S1: SG1 = 0111 1111

Settings of extension unit S2: 0011 1111

Settings of extension unit S3: CBFP not in use: SG1 = 1011 0000

Settings of extension unit S4: CBFP not in use: SG1 = 0011 0000

Circuit-breaker failure protection, with 150 ms delay, used in extension units S3 and S4:

S3: SG1 = 1011 0110

S4: SG1 = 0011 0110

Example 8

Substation with two power transformers, equipped with a bus coupler.

Since the fault current can arrive from two supply directions, two REA 101 central units, one for each direction, are required. The arc sensor loops of the central units have been arranged so that the bus coupler Q5 separates the areas to be protected. When an arc occurs, the concerned central unit trips its own in-feeder circuit breaker and the bus coupler, the healthy part of the switchgear remaining connected. The central units send on/off overcurrent information to each other over the signal transfer fiber connection.

In this case, it is enough for the protection relay to operate if one of the units detects overcurrent, even in a situation where one transformer is out of service and the other transformer feeds the whole switchgear over the bus coupler. The REA 105 extension units perform selective tripping in situations where the arc fault is located behind the concerned circuit breakers.

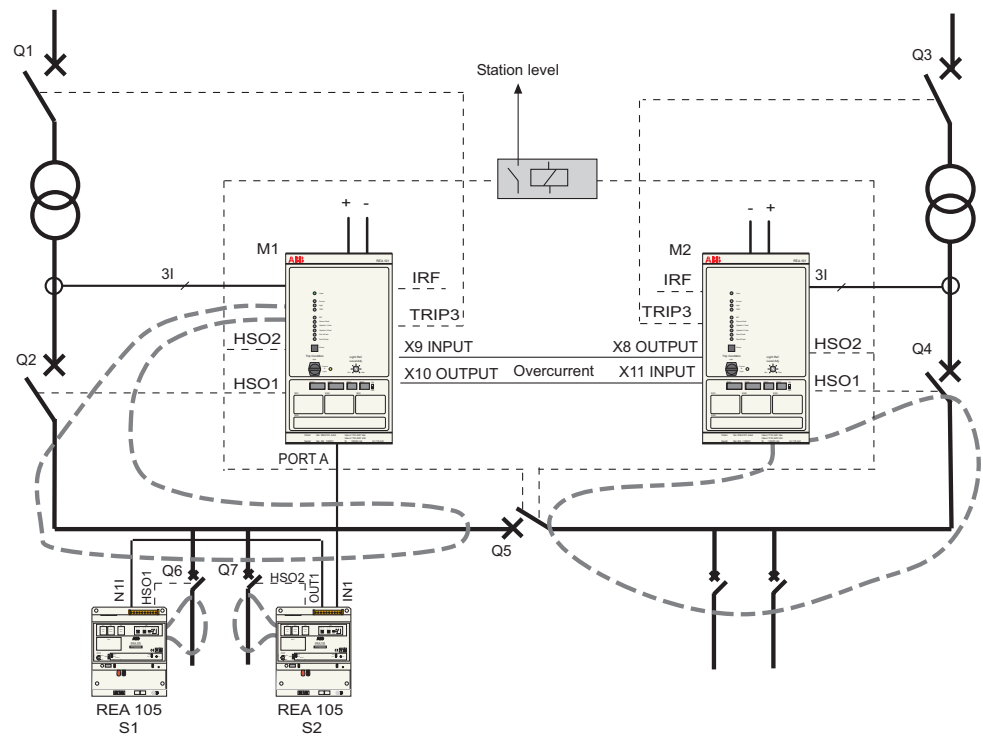

A050522

Fig. 10.2.-8 Example 8

Settings of central unit M1:

SG1 = 1001 1110 SG2 = 1100 0100 SG3 = 01100 SG4 = 00000

Settings of central unit M2:

SG1 = 1001 1100 SG2 = 0100 1100 SG3 = 01100 SG4 = 00000

Settings of extension units S1 and S2: CBFP not in use

S1: SG1 = 1011 0000

S2: SG1 = 0011 0000

Circuit-breaker failure protection with 150 ms delay used in extension units S1 and S2:

S1: SG1 = 1011 0110

S2: SG1 = 0011 0110

If the circuit-breaker failure protection of the in-feeder circuit breakers is out of use, the TRIP3 can be used to provide information for the substation level. Then no intermediate relay is needed.

Settings of central unit M1, when TRIP3 provides information to the substation level:

SG1 = 1001 1110 SG2 = 1100 0100 SG3 = 00000 SG4 = 00000

Settings of central unit M2, when TRIP3 provides information to the substation level:

SG1 = 1001 1100 SG2 = 0100 1100 SG3 = 00000 SG4 = 00000

Example 9

The functions of this application corresponds to that described in the example 8. The difference is that the overcurrent signals between the central units are transmitted via the connection cable of the extension units. An REA 105 unit (not REA 103) has to be used in the connection point between the coverage areas of the central units. This REA 105 unit can normally be used as a part of the system that ends in a central unit in the direction of the terminal IN1. Since the links from both directions end in extension unit S3, the terminators of the ports IN1 and IN2 have to be connected (SG1/1, 2 = ON).



When the REA 10_ units in the same arc protection system are located in separate switchgears, the connection between the REA 10_ units must be made by using optolink. (Unless it can be ensured that the switchgears are in the same potential in all conditions).

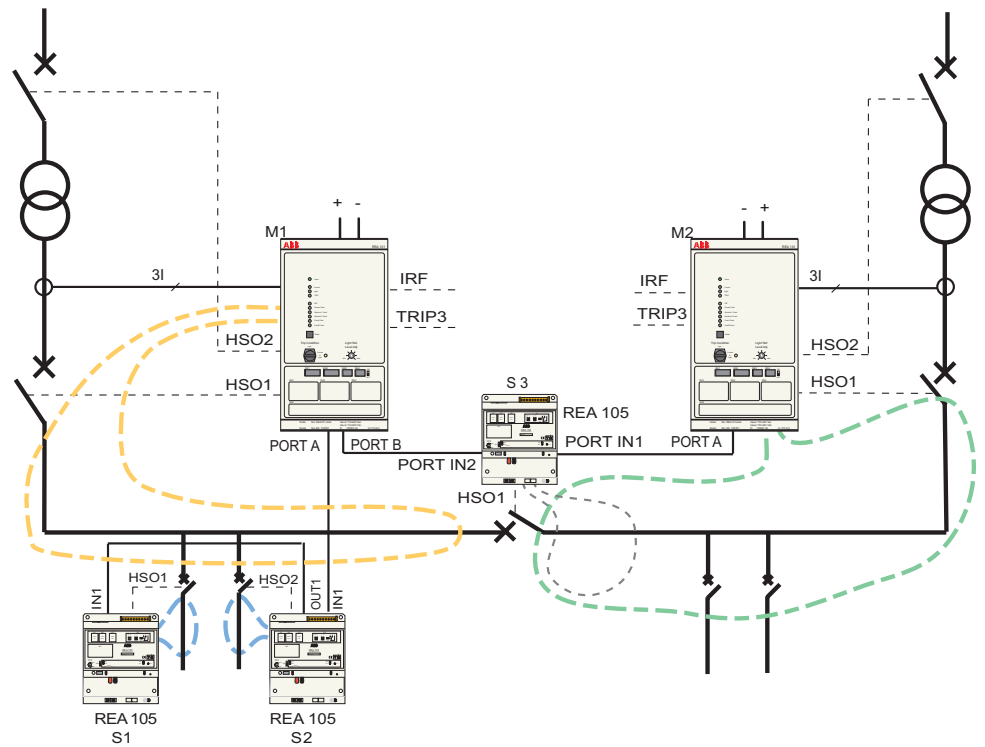

A050523

Fig. 10.2.-9 Example 9

Operator's Manual

Settings of central unit M1:

SG1 = 1001 1111 SG2 = 0000 0000 SG3 = 10100 SG4 = 00000

Settings of central unit M2:

SG1 = 1001 1110 SG2 = 0000 0000 SG3 = 10100 SG4 = 00000

Settings of extension units S1 and S2: CBFP not in use

S1: SG1 = 1011 0000

S2: SG1 = 0011 0000

Settings of extension units S1 and S2: CBFP with 150 ms delay in use

S1: SG1 = 1011 0110

S2: SG1 = 0011 0110

Settings of extension unit S3:

SG1 = 1111 1000

Example 10

Substation with three power transformers.

Each in-feeder has its own central unit measuring fault current. Overcurrent data is transmitted to each extension unit over the connection cable of the units. Once the central unit M1 or the extension unit S1 detects an arc, the circuit breakers Q2 and Q3 are opened. When the central unit M2 or the extension unit S3 detects a fault, the circuit breakers Q3, Q5 and Q6 are opened. Correspondingly, when the M3 or the S2 unit detects an arc, the circuit breakers Q6 and Q8 will be opened. This arrangement allows just the faulty part of the switchgear to be disconnected. The extension units S1 and S2 are located in the section where the protection areas are separated so the connection cables from both directions have to be terminated (SG1/1, 2 = ON). The trip signal of the circuit-breaker failure protection of the three central units is linked to the transformer primary circuit breakers (Q1, Q4 and Q7), with a delay of 150 ms.

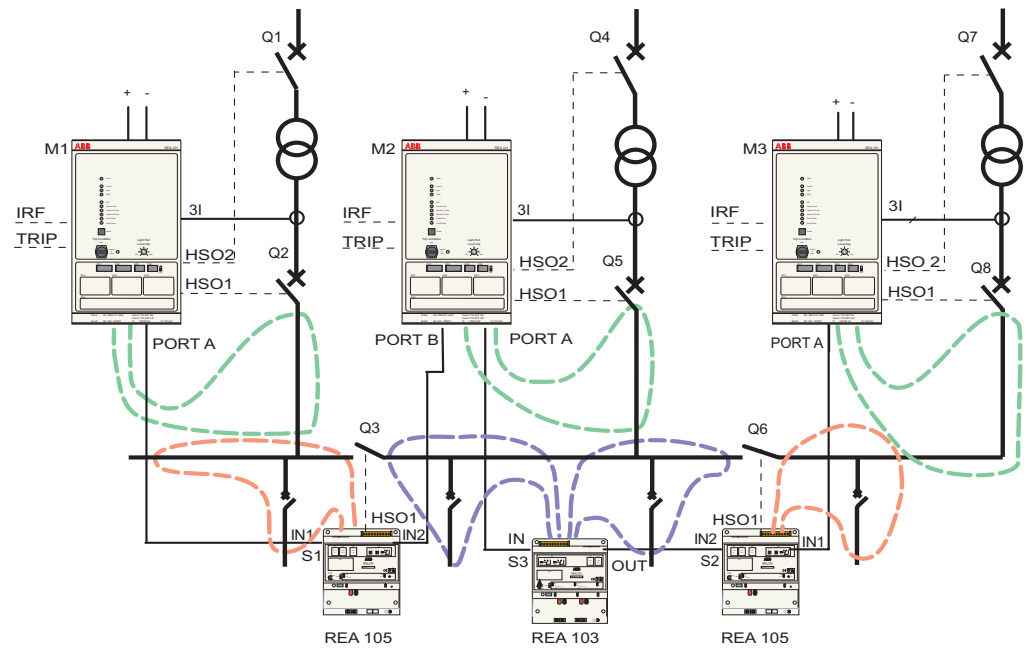

A050524

Fig. 10.2.-10 Example 10

Settings of central unit M1:

SG1 = 1001 1110 SG2 = 0000 0000 SG3 = 10100 SG4 = 00000

Settings of central unit M2:

SG1 = 1001 1111 SG2 = 0000 0000 SG3 = 10100 SG4 = 00000

Settings of central unit M3:

SG1 = 1001 1110 SG2 = 0000 0000 SG3 = 10100 SG4 = 00000

Settings of extension units S1 and S2:

SG1 = 1101 1000

Settings of extension unit S3:

SG1 = 00110

Example 11

REA 101 is used to protect the switchgear against an arc caused by short-circuit or earth-fault current.

The arc sensor loop of the relay passes through all the spaces that are to be protected. Tripping requires a light signal generated by an arc, and a current signal generated by a short-circuit or earth-fault current.

- Short-circuit current is measured by the inputs L1 and L3 (5 A or 1 A). The current threshold of the inputs can be set to 0.5...6 In.
- Earth-fault current is measured by the input L2 (5 A or 1 A). The current threshold of the input can be set to 0.05...0.6 In.

For details, refer to Chapter 4. Connection diagram.

When an arc occurs, the Q2 circuit breaker is operated via the semiconductor output HSO1.

In alternative 2, the semi-conductor output HSO2 is used as a circuit-breaker failure protection output. If the feeder circuit breaker Q2 for some reason is unable to break the fault current within 100 ms after the trip operation, the circuit breaker Q1 on the transformer primary side is opened via output HSO2.

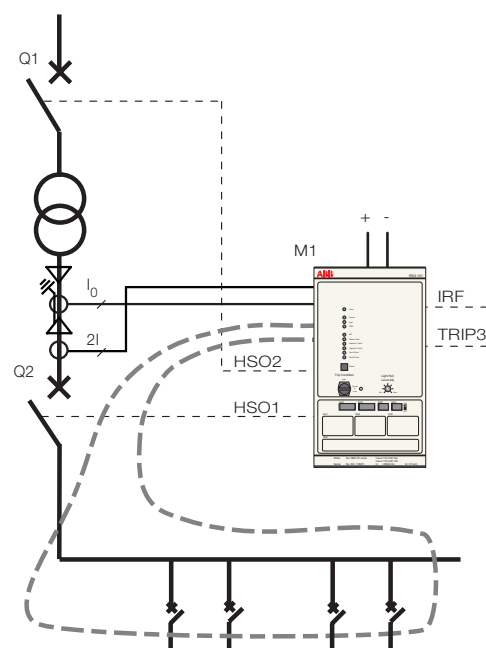

A050810

Fig. 10.2.-11 Example 11

Settings of central unit M1:

- Alternative 1:

SG1 = 1001 0100 SG2 = 0000 0000 SG3 = 00000 SG4 = 01011

HSO2 is not used as CBFP, that is, HSO2 operates at the same time as HSO1.

- Alternative 2:

SG1 = 1001 0100 SG2 = 0000 0000 SG3 = 10000 SG4 = 01011

HSO2 is used as CBFP, time delay 100 ms.

11. Technical data

Table 11.-1 Current input

Rated current	1 A / 5 A
Continuous load current	4 A / 20 A
Momentary current for 1 s	100 A / 500 A
Dynamic current withstand, half-wave value	250 A / 1250 A
Input impedance	<100 mΩ / <20 mΩ
Rated frequency	50 / 60 Hz

Table 11.-2 Outputs

Trip contacts HSO1 and HSO2:	
Rated voltage	250 V DC/AC
Continuous carry	1.5 A
Make and carry for 0.5 s	30 A
Make and carry for 3 s	15 A
Breaking capacity for DC, when the control circuit time constant L/R <40 ms, at 48/110/220 V DC	5 A/3 A/1 A
Trip contact TRIP3:	
Rated voltage	250 V DC/AC
Continuous carry	5 A
Make and carry for 0.5 s	30 A
Make and carry for 3 s	15 A
Breaking capacity for DC, when the control circuit time constant L/R <40 ms, at 48/110/220 V DC	5 A/3 A/1 A
Signal contacts IRF:	
Rated voltage	250 V DC/AC
Continuous carry	5 A
Make and carry for 0.5 s	10 A
Make and carry for 3 s	8 A
Breaking capacity for DC, when the control circuit time constant L/R <40 ms, at 48/110/220 V DC	1 A/0.25 A/0.15 A

Table 11.-3 Control input

Reset input RESET:	
Control voltages:	
Rated voltages and operating ranges	$U_n =$ 24/48/60/110/220/250 V DC 18...300 V DC $U_n = 110/120/220/$ 240 V AC 18...265 V AC
Not active, when control voltage	< 9 V DC, 6 V AC
Control current	1.5...20 mA
Minimum pulse length	1 s

Table 11.-4 Circuit-breaker failure protection CBFP

Selectable operate time delays	150 ms / 100 ms
Operate time accuracy:	
HSO2	±5% of setting value
TRIP3	±5% of setting value +5...15 ms

Table 11.-5 Power supply

Relay types REA101-AAA, REA101-AAAG:	
• U_{aux} rated	$U_r = 110/120/220/240$ V AC $U_r = 110/125/220/250$ V DC
• U_{aux} variation	85...110% U_r (AC) 80...120% U_r (DC)
Relay types REA101-CAA, REA101-CAAG:	
• U_{aux} rated	$U_r = 24/48/60$ V DC
• U_{aux} variation	80...120% U_r DC

Table 11.-6 Power consumption

Power consumption of relay under quiescent/ operating conditions	~9 W / ~12 W
Maximum port output power	~19 W
Maximum number of extension units/port	5
Maximum power consumption with 10 extension units connected	<50 W

Table 11.-7 Sensor fiber

Maximum length without splices or with one splice	60 m
Maximum length with two splices	50 m
Maximum length with three splices	40 m
Service temperature range	-35...+80°C
Smallest permissible bending radius	50 mm

Table 11.-8 Connection cable

Maximum length ^a	40 m
-----------------------------	------

a. Total length of the connection chain between the central unit and extension units

Table 11.-9 Optolink communication

Maximum length of signal transfer fiber:	
• Plastic	40 m
• Glass ^a	2000 m

a. For more details, refer to Chapter 13. Appendix A: Glass fiber optolink connection.

Table 11.-10 Setting range

Current setting steps $I_n \times$	0.5, 1.0, 1.5, 2.5, 3.0, 5.0, 6.0
Neutral current setting steps $I_n \times$	0.05, 0.10, 0.15, 0.25, 0.3, 0.5, 0.6
Operation accuracy	$\pm 5\%$ of the setting value or $\pm 2\%$ of I_n

Table 11.-11 Total operate times

HSO1 and HSO2	≤ 2.5 ms
TRIP3	< 15 ms

Table 11.-12 Environmental tests

Specified service temperature range	$-10 \dots +55^\circ\text{C}$
Transport and storage temperature range	$-40 \dots +70^\circ\text{C}$
Operation in dry heat conditions	According to IEC 60068-2-2
Operation in dry cold conditions	According to IEC 60068-2-1
Damp heat test cyclic	According to IEC 60068-2-30 r.h. $> 95\%$, $t = 20 \dots 55^\circ\text{C}$
Storage temperature test	According to IEC 60068-2-48

Table 11.-13 Enclosure

Degree of protection, IEC 60529	IP 20
Weight	~ 4.6 kg

Table 11.-14 Insulation tests

Dielectric tests according to IEC 60255-5	2 kV, 50 Hz, 1 min.
Impulse voltage test according to IEC 60255-5	5 kV, 1.2/50 μs , 0.5 J
Insulation resistance according to IEC 60255-5	> 100 M Ω , 500 V DC

Table 11.-15 Electromagnetic compatibility tests

EMC immunity test level meets the requirements listed below:	
1 MHz burst disturbance test according to IEC 60255-22-1, class III:	
• Common mode	2.5 kV
• Differential mode	1 kV
Electrostatic discharge test according to IEC 61000-4-2, class IV and ANSI/IEEE C37.90.3-200:	
• For contact discharge	8 kV
• For air discharge	15 kV
Radio-frequency electromagnetic field disturbance test according to IEC 61000-4-3 and IEC 60255-22-3:	
Amplitude-modulated:	
• Frequency f	80...1000 MHz
• Field strength E	10 V/m (rms)
Pulse-modulated:	
• Frequency f	900 MHz
• Field strength E	10 V/m (rms)

Table 11.-15 Electromagnetic compatibility tests (Continued)

Radio frequency disturbance test according to IEC 61000-4-6 and IEC 60255-22-6:	
• Conducted, common mode	10 V, 150 kHz...80 MHz
Fast transient disturbance tests according to IEC 60255-22-4 and IEC 61000-4-4	4 kV
Surge immunity test according to IEC 61000-4-5 and IEC 60255-22-5:	
Aux. voltage input, trip outputs:	
• Line-to-line	2 kV
• Line-to-earth	4 kV
Signal contacts (IRF), current inputs, RESET input:	
• Line-to-line	1 kV
• Line-to-earth	2 kV
Electromagnetic emission tests according to EN 55011 and IEC 60255-25:	
• Conducted RF emission (mains terminal)	EN 55011, class A, IEC 60255-25
• Radiated RF emission	EN 55011, class A, IEC 60255-25
SWC tests according to ANSI/IEEE C37.90.1-2002:	
• Oscillatory tests	2.5 kV
• Fast transient test	4 kV
Power frequency (50 Hz) magnetic field according to IEC61000-4-8	300 A/m, continuous
Voltage dips and short interruptions according to IEC 61000-4-11:	
	30%/10 ms 60%/100 ms 60%/1000 ms >95%/5000 ms

Table 11.-16 CE approval

Complies with the EMC directive 89/336/EEC and the LV directive 73/23/EEC	EN 50263 EN 60255-6
---	------------------------

Table 11.0.-1 Mechanical tests

Vibration tests (sinusoidal) according to IEC 60255-21-1	class 1
Shock and bump test according to IEC 60255-21-2	class 1
Seismic tests according to IEC 60255-21-3	class 2

12. Order information

12.1. REA 10_ units

Table 12.1.-1 Order numbers

Arc protection relay REA 101 $U_n = 110...240$ V AC $U_n = 110...250$ V DC	REA101-AAA ^a
Arc protection relay REA 101 $U_n = 24...60$ V DC	REA101-CAA ^a
Arc protection relay REA 101 with optolink connectors for glass fiber $U_n = 110...240$ V AC $U_n = 110...250$ V DC	REA101-AAAG ^a
Arc protection relay REA 101 with optolink connectors for glass fiber $U_n = 24...60$ V DC	REA101-CAAG ^a
Rear plate protective cover	1MRS 060196
Mounting kit for semi-flush mounting	1MRS 050254
Mounting kit for surface mounting	1MRS 050240
Mounting kit for connecting cases together	1MRS 050241
Mounting kit for 19" rack	1MRS 050258
Extension unit REA 103	REA103-AA
Extension unit REA 105	REA105-AA
Extension unit REA 107	REA 107-AA

a. Includes mounting kit 1MRS 050209 for flush mounting.

12.2. Fiber sensors

Table 12.2.-1 Pre-manufactured fiber sensors

Length	Order number
5 m $\pm 3\%$	1MRS 120512.005
10 m $\pm 3\%$	1MRS 120512.010
15 m $\pm 3\%$	1MRS 120512.015
20 m $\pm 3\%$	1MRS 120512.020
25 m $\pm 3\%$	1MRS 120512.025
30 m $\pm 3\%$	1MRS 120512.030
40 m $\pm 3\%$	1MRS 120512.040
50 m $\pm 3\%$	1MRS 120512.050
60 m $\pm 3\%$	1MRS 120512.060

Table 12.2.-2 Accessories for manufacturing fiber sensors

Sensor fiber 100 m	1MSC 380018.100
Sensor fiber 300 m	1MSC 380018.300
Sensor fiber 500 m	1MSC 380018.500
ST connector	SYJ-ZBC 1A1
ST splice adapter	SYJ-ZBC 1A2
ST fiber termination kit	1MSC 990016

12.3. Lens sensors

Table 12.3.-1 Pre-manufactured lens sensors for REA 107

1,5 m ±3%	1MRS 120534-1.5
3 m ±3%	1MRS 120534-3.0
5 m ±3%	1MRS 120534-5.0
7 m ±3%	1MRS 120534-7.0
10 m ±3%	1MRS 120534-10
15 m ±3%	1MRS 120534-15
20 m ±3%	1MRS 120534-20
25 m ±3%	1MRS 120534-25
30 m ±3%	1MRS 120534-30

Table 12.3.-2 Pre-manufactured lens sensors for REA 101, REA 103 and REA 105

2 m ±3%	1MRS 120536-2
3 m ±3%	1MRS 120536-3
5 m ±3%	1MRS 120536-5
10 m ±3%	1MRS 120536-10

Table 12.3.-3 Spare parts for lens sensors

Light collecting lens	1MRS060743
-----------------------	------------

12.4. Connection cables

Table 12.4.-1 Cables for connecting REA 101 to an extension unit, or the extension units to each other

1 m ±3%	1MRS 120511.001
3 m ±3%	1MRS 120511.003
5 m ±3%	1MRS 120511.005
10 m ±3%	1MRS 120511.010
15 m ±3%	1MRS 120511.015
20 m ±3%	1MRS 120511.020
30 m ±3%	1MRS 120511.030
40 m ±3%	1MRS 120511.040

Table 12.4.-2 Plastic fiber optolink for signal transfer between central units

1 m \pm 3%	SPA-ZF AA 1
2 m \pm 3%	SPA-ZF AA 2
3 m \pm 3%	SPA-ZF AA 3
5 m \pm 3%	SPA-ZF AA 5
10 m \pm 3%	SPA-ZF AA 10
20 m \pm 3%	SPA-ZF AA 20
30 m \pm 3%	SPA-ZF AA 30
40 m \pm 3%	1MRS 120517

Table 12.4.-3 Glass fiber optolink for signal transfer between central units

Refer to Chapter 13. Appendix A: Glass fiber optolink connection
--

13. Appendix A: Glass fiber optolink connection

The glass fibers used for signal transfer in optolink communication between REA 101 central units must comply with:

- Specifications in this chapter
- International standard ISO/IEC 11801

Glass fiber type

The glass fiber must be multimode graded-index type. Multimode means that the light rays can travel several paths. Graded-index means that the refractive index varies with the distance from the fiber axis. This means that the light ray refracts in small steps and the pulse keeps its shape better than when using, for example, step index fibers.

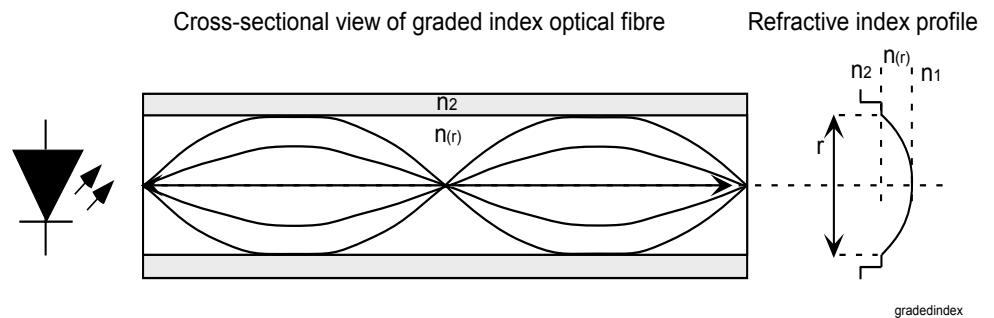

Fig. 13.-1 Graded-index fiber

Connector type

The supported connector type for glass fibers in REA 101 is ST.

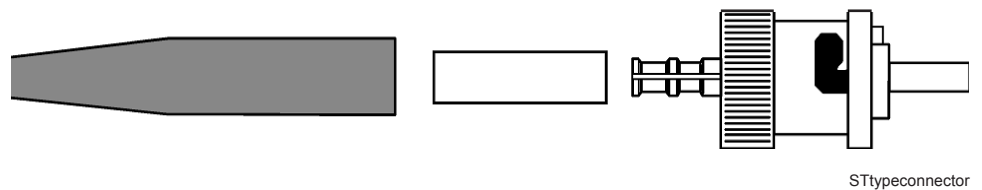

Fig. 13.-2 ST-type connector

Technical data

Table 13.0.-1 Technical data for glass fiber

Type	Multimode graded-index OM1 (ISO/IEC11801)
Diameter	62.5/125 µm core/cladding
Attenuation	Max. 3.5 dB/km at 850 nm wavelength
Tip polishing shape	Rounded fiber tip
Connector	ST type

Ordering

You can order fibers of fixed lengths from well-known manufacturers or distributors.

For cable lengths and system constructions, always follow the design rules of different communication protocols.

There are many reliable manufacturers who can deliver the fibers. ABB has successfully tested fibers from the following manufacturers:

Draka NK Cables

Brügg Kabel AG



ABB Oy

Distribution Automation

P.O. Box 699

FI-65101 Vaasa

FINLAND

Tel. +358 10 22 11

Fax. +358 10 224 1094

www.abb.com/substationautomation