



Relion® 605 series

Self-Powered Feeder Protection REJ603 Product Guide

Contents

1 Description	3	7 LED and FLAG indications	4
2 Protection functions	3	8 Optional HMI	4
3 Application	4	9 Technical data	5 - 9
4 Self-supervision	4	10 Connection and Terminal Diagram	10 - 11
5 Inputs and outputs	4	11 Dimension and Mounting	12 -13
6 Testing	4	12 Ordering Details	14

Disclaimer

The information in this document is subject to change without notice and should not be construed as a commitment by ABB Ltd.. ABB Ltd. assumes no responsibility for any errors that may appear in this document.

Copyright © 2010 ABB Ltd.

All rights reserved.

Trademarks

ABB is a registered trademark of ABB Group. All other brand or product names mentioned in this document may be trademarks or registered trademarks of their respective holders.

1. Description

The feeder protection relay REJ603 is part of the feeder protection series of relays, intended for the protection of secondary distribution network in utilities and industries.

The feeder protection relay REJ603 is designed to be an integral part of the most popular Safering Ring Main Unit (RMU) and Safeplus compact switchgear. The REJ603 relay is a self-powered numerical relay, which derives power from the main current transformers. This way REJ603 relay ensures complete installation protection even without an auxiliary supply and hence is suitable for unmanned distribution substations having no auxiliary services.

2. Protection Functions

The relay principally offers three phase non-directional overcurrent (low-set and high-set stage) and non-directional earth-fault protection (low-set and high-set stage).

Protection Functions of REJ603

Protection	IEC	ANSI
Three phase overcurrent protection, low-set stage	$3I>$	51
Three phase overcurrent protection, high-set stage	$3I>>$	50 / 51
Earth-fault protection, low-set stage	$I_0>$	51N
Earth-fault protection, high-set stage	$I_0>>$	50N / 51N
Three phase transformer inrush detector	$3I_{2f}>$	68

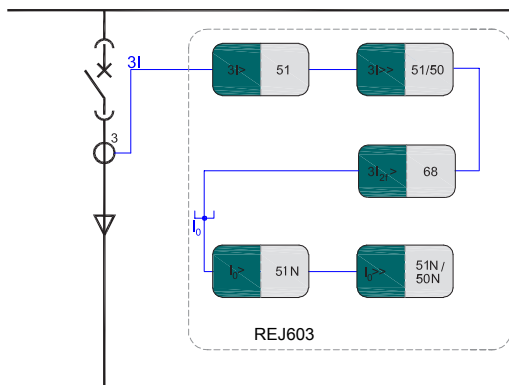

Fig. 1. Protection overview of Self-powered feeder protection REJ603 with earth current measurement by internal calculation

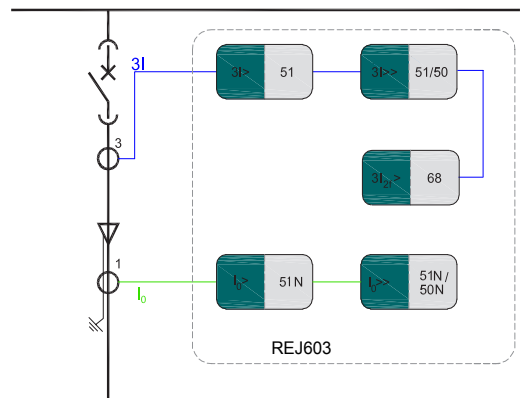

Fig. 2. Protection overview of Self-powered feeder protection REJ603 with earth current measurement by external CBCT

3. Application

REJ603 is intended to be used for the selective short-circuit and earth-fault protection of feeders in secondary distribution networks and for protection of transformers in utilities and industries. The relay is a self-powered Numerical relay, which does not require an external auxiliary supply voltage, making it an ideal choice for installation even in remote locations where auxiliary supplies are not available. The relay derives power for its operation from the current transformers. REJ603 is primarily used in Ring Main Units (RMU) within distribution network.

Relay provides earth current measurement through internal calculation or has the provision for measuring it from the external core balance current transformer (CBCT).

4. Self-supervision

The relay's built-in self-supervision system continuously monitors the state of the relay hardware and the operation of the relay software. When a relay fault is detected, the IRF LED will glow red. In the event of a critical relay failure, all the protection functions of the relay will be completely blocked to prevent any incorrect relay operation.

Additionally, the relay offers fail safe trip in the combined event of critical internal relay failure and phase currents exceeding twenty times the maximum nominal current value.

5. Inputs and outputs

- Three CT inputs for phase current and internally calculated earth-fault measurement
- One core balance current transformer (CBCT) input for earth fault measurement
- One binary input for remote trip
- One impulse output for low energy trip coil

6. Testing

The special CT's for REJ603 have a test winding to simulate primary current for testing of complete protection scheme including primary CT, relay, and trip coil.

7. LED and flag indications

- Ready LED
- IRF LED
- Trip Flag: Built-in hand-reset electromechanical flag for overcurrent or earth-fault trip indication
- Reset pushbutton for trip flag

8. Optional HMI

As a primary user interface, the REJ603 has DIP switches, few LEDs and a electromechanical flag for trip indication. Although this interface is sufficient for basic self-powered protection applications, certain installations may require a interface like conventional auxiliary powered relays. Such requirement can be fulfilled with the optional battery powered HMI (Human Machine Interface) which features a unique touch screen display. The available functionality with HMI, includes segregated trip indication, events with time stamp, fault record, display of primary values, fault codes etc., which help in post fault analysis. The HMI also overcomes the limitation of setting resolution posed by DIP switches and allows finer settings as well as setting of additional parameters.

9. Technical data

Dimensions

Width	96 mm
Height	160 mm
Depth	149 mm (w/o HMI), 150 mm (with HMI)

Energizing Inputs

Rated Frequency	50/60 Hz \pm 5 Hz		
Phase inputs	Nominal primary current		
	CT type	Rated CT current range $I_s (I_{smin} - I_{smax})$	
	REJ603-CT1	8 - 28 A	
	REJ603-CT2	16 - 56 A	
	REJ603-CT3	32 - 112 A	
	REJ603-CT4	64 - 224 A	
	REJ603-CT5	128 - 448 A	
	Thermal withstand capability	<ul style="list-style-type: none"> Continuously For 1 s For 3 s 	$2.5 \times I_{smax}$ 25 kA primary current 20 kA primary current
Dynamic current withstand:	<ul style="list-style-type: none"> Half-wave value 	62.5 kA primary current	
Earth input	Rated current, I_n	1 A	
	Thermal withstand capability	<ul style="list-style-type: none"> Continuously For 1 s 	4 A 100 A
	Dynamic current withstand:	<ul style="list-style-type: none"> Half-wave value 	250 A
	Input impedance	< 100 m Ω	

Binary inputs

Rated voltage	24 - 240 V AC/DC
Operating range	-15%...+10% for AC , -30% ... +20% for DC
Current drain	2...15 mA
Power consumption	< 0.8 W
Threshold voltage	13 V AC/17 V DC

Impulse voltage trip output

Rated output voltage	12 V
Pulse time	30 ms
Energy	50 mJ

Setting range and accuracy

Setting range of nominal current I_s

REJ603-CT1	8	9	10	11	12	13	14	15	16	17	18	20	22	24	26	28
REJ603-CT2	16	18	20	22	24	26	28	30	32	34	36	40	44	48	52	56
REJ603-CT3	32	36	40	44	48	52	56	60	64	68	72	80	88	96	104	112
REJ603-CT4	64	72	80	88	96	104	112	120	128	136	144	160	176	192	208	224
REJ603-CT5	128	144	160	176	192	208	224	240	256	272	288	320	352	384	416	448

Low-set phase over-current protection stage I>

Measuring range	$0.9 \times I_{smin} \dots 20 \times I_{smax}$
Setting range of pick-up current I>	$0.9 \dots 2.5 \times I_s$
Setting resolution/steps	$I_s \times 0.9 \dots 2.5$ (31 steps), exit
Accuracy of pick-up current	$\pm 5\%$ of set value in the temperature range $0 \dots 70^\circ\text{C}$ $\pm 7.5\%$ of set value in the temperature range $-40 \dots 85^\circ\text{C}$
Setting range of definite time delay t>	0.05...3.0 sec
Setting resolution/steps	0.05, 0.07, 0.1, 0.15, 0.2, 0.25, 0.3, 0.4, 0.6, 0.8, 1.0, 1.4, 1.8, 2.2, 2.6, 3.0
Accuracy of operate time	$\pm 1\%$ or 10 ms, whichever is greater
Setting of inverse time characteristics	IEC 255-3: Normal Inverse, Very Inverse, Extremely Inverse, Long time Inverse Special Curves: RI Inverse Time, HR-Fuse, FR-Fuse
Setting range of time multiplier k	0.05...3.0
Setting resolution/steps	0.05, 0.07, 0.1, 0.15, 0.2, 0.25, 0.3, 0.4, 0.6, 0.8, 1.0, 1.4, 1.8, 2.2, 2.6, 3.0
Accuracy of operate time IEC characteristics RI characteristics HR, FR curve characteristics	class E(5) or ± 35 ms, whichever is greater As per NI(IEC) curve $\pm 20\%$ of set value or ± 35 ms, whichever is greater

High-set phase overcurrent protection stage I>>

Setting range of pick-up current I>>	$1 \dots 20 \times I_s$
Setting resolution/steps	$I_s \times 1, 2, 3, 4, 5, 6, 7, 8, 9, 10, 12, 14, 16, 18, 20$, exit
Accuracy of pick-up current	$\pm 5\%$ of set value in the temperature range $0 \dots 70^\circ\text{C}$ $\pm 7.5\%$ of set value in the temperature range $-40 \dots 85^\circ\text{C}$
Setting range of definite time delay t>>	0.04...3.0 sec
Setting resolution/steps	0.04, 0.07, 0.1, 0.15, 0.2, 0.25, 0.3, 0.4, 0.6, 0.8, 1.0, 1.4, 1.8, 2.2, 2.6, 3.0
Accuracy of Operate time	$\pm 1\%$ or 10 ms, whichever is greater

(continued)

Low-set earth-fault protection stage I₀>	
Nominal value of earth current • Internal measurement • External measurement	I _s I _n : 1 A
Measurement range	0.9 x I _{smin} ... 20 x I _{smax} / 0.1...20 x I _n
Setting range of pick-up current I ₀ >	0.1...1 x I _s / 0.1 - 1 x I _n
Setting resolution/steps	I _s or I _n x 0.1...1.0 (31 steps), exit
Accuracy of pick-up current Internal measurement External measurement	±3% of I _s in the temperature range 0...70°C ±7.5% of I _s in the temperature range -40...85°C ±5% of I _n in the temperature range 0...70°C ±20% of I _n in the temperature range -40...85°C
Setting range of definite time delay t ₀ >	0.05...3.0 sec
Setting resolution/steps	0.05, 0.07, 0.1, 0.15, 0.2, 0.25, 0.3, 0.4, 0.6, 0.8, 1.0, 1.4, 1.8, 2.2, 2.6, 3.0
Accuracy of operate time	±1% or 10 ms, whichever is greater
Setting of inverse time characteristics	IEC 255-3: Normal Inverse, Very Inverse Extremely Inverse, Long time Inverse Special Curves: RI Inverse Time, HR-Fuse, FR-Fuse
Setting range of time multiplier k ₀	0.05...3.0
Setting resolution/steps	0.05, 0.07, 0.1, 0.15, 0.2, 0.25, 0.3, 0.4, 0.6, 0.8, 1.0, 1.4, 1.8, 2.2, 2.6, 3.0
Accuracy of operate time IEC characteristics RI characteristics HR, FR curve characteristics	class E(5) or ±35 ms, whichever is greater As per NI(IEC) curve ±20% of set value or ±35 ms, whichever is greater
High-set earth-fault protection stage I₀>>	
Setting range of pick-up current I ₀ >>	1...20 x I _s / 1...20 x I _n
Setting resolution/steps	I _s or I _n x 1, 2, 3, 4, 5, 6, 7, 8, 9, 10, 12, 14, 16, 18, 20, exit
Accuracy of pick-up current Internal measurement External measurement	±3% of set value in the temperature range 0...70°C ±7.5% of set value in the temperature range -40...85°C ±5% of set value in the temperature range 0...70°C ±15% of set value in the temperature range -40...85°C
Setting range of definite time delay t ₀ >>	0.04...3.0 sec
Setting resolution/steps	0.04, 0.07, 0.1, 0.15, 0.2, 0.25, 0.3, 0.4, 0.6, 0.8, 1.0, 1.4, 1.8, 2.2, 2.6, 3.0
Accuracy of operate time	±1% or 10 ms, whichever is greater

Degree of protection by enclosure

Front portion with cover	IP 54
Side with connection terminals	IP 20

Environmental conditions and tests

Environmental conditions

Service temperature range	-25...+85°C (relay without HMI) -25...+70°C (relay with HMI)
Relative humidity	< 93%
Atmospheric pressure	86...106 kPa
Altitude	up to 2000 m
Transport and storage temperature range	-40...+85°C

Environmental tests

Dry heat test	According to IEC 60068-2-2 Test values: • 16 h at +70°C • 96 h at +85°C
Dry cold test	According to IEC 60068-2-1 Test values: • 16 h at -25°C • 96 h at -40°C
Damp heat test, cyclic	According to IEC 60068-2-30 Test values: • 2 cycles at +25...55°C humidity 95...97%
Damp heat test, steady state	According to IEC 60068-2-78 Test values: • 96 h at +40°C humidity 94%
Storage test	According to IEC 60068-2-48 Test values: • 96 h at +85°C • 96 h at -40°C

Electromagnetic compatibility tests

The EMC immunity test level meets the requirements listed below:

1 MHz burst disturbance test • Common mode • Differential mode	According to IEC 61000-4-12 and IEC 60255-22-1 2.0KV, 1MHz, 400 pulses/sec 1.0KV, 1MHz, 400 pulses/sec
Electrostatic discharge test • Contact discharge • Air discharge	According to IEC 60255-22-2, class III, 6kV, 150 pF/330 Ω 8kV, 150 pF/330 Ω
Radiated, electro-magnetic field immunity test	According to IEC 60255-22-3, level III, Test values: 10 V/m, f = 80...1000 MHz

(continued)

Electrical fast transient disturbance test	According to IEC 60255-22-4, class A, 4 kV, 2.5 kHz
Surge immunity test <ul style="list-style-type: none"> • Common mode • Differential mode 	According to IEC 60255-22-5, and IEC 61000-4-5 1 kV, 1.2/50 μ s, $R_s=42 \Omega$ 0.5 kV, 1.2/50 μ s, $R_s=42 \Omega$
Immunity to conducted disturbances induced by radio frequency fields	According to IEC 60255-22-6, level III, Test values: 10V, f=150 KHz...80 MHz 27MHz and 68 MHz (spot freq.)
Conducted and radiated radio-frequency emission tests <ul style="list-style-type: none"> • Conducted emission (mains) • Radiated emission 	According to IEC 60255-25, EN550 11-CISPR II Frequency range: 30-230 MHz, Limits dB(μ V/m):40 Frequency range: 230-1000 MHz, Limits dB(μ V/m):47
Power frequency magnetic field immunity test <ul style="list-style-type: none"> • Continuous • Short duration (10 s) 	According to IEC 61000-4-8 <ul style="list-style-type: none"> • level V, 100 A/m • 300 A/m
Pulse magnetic field immunity test	According to IEC 61000-4-9, 1000 A/m, 6.4/16 μ s Tr/Th

Insulation and mechanical tests

Insulation tests

Dielectric test	According to IEC 60255-5, Test values: 2 KV, 50 HZ for 1 min.
Impulse voltage test	According to IEC 60255-5, Test values: 5 kV, 1.2/50 μ s, 0.5 J
Insulation resistance test	>100 M Ω at 500 V DC

Mechanical tests

Vibration tests <ul style="list-style-type: none"> • Response • Endurance 	According to IEC 60255-21-1, class 1, Test values 10...150 Hz, 0.035 mm/0.5 g, 1 sweep/axis 10...150 Hz, 1 g, 20 sweeps/axis
Shock test <ul style="list-style-type: none"> • Response • Withstand 	According to IEC60255-21-2, class 2, 10 g, 3 pulses in each direction 30 g, 3 pulses in each direction
Bump test	According to IEC60255-21-2, class 2, 20 g, 1000 bumps in each direction

10. Connection and terminal diagram

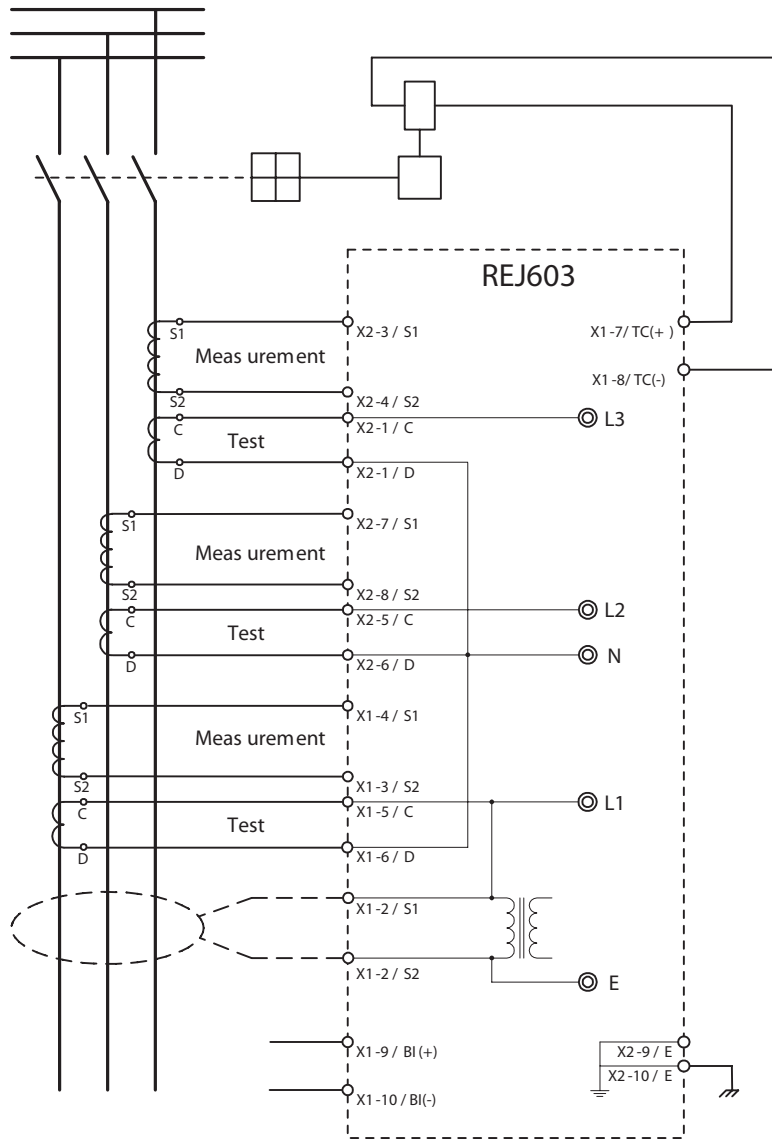

Fig. 3. Connection diagram of Self-powered feeder protection REJ603

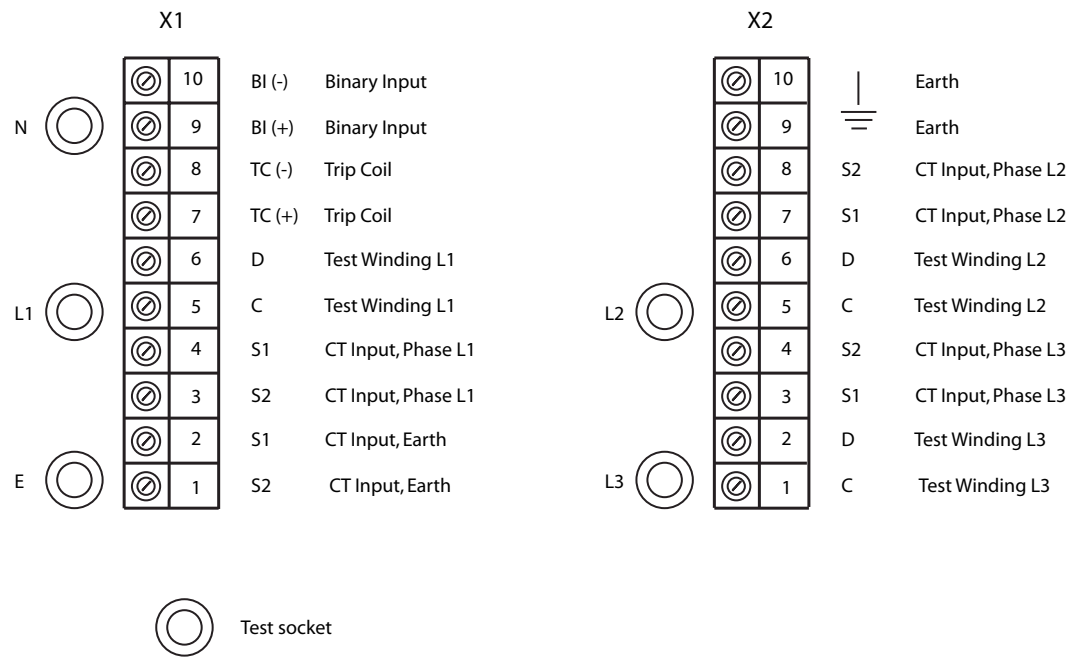

Fig. 4. Terminal arrangement of Self-powered feeder protection REJ603

11. Dimensions and mounting

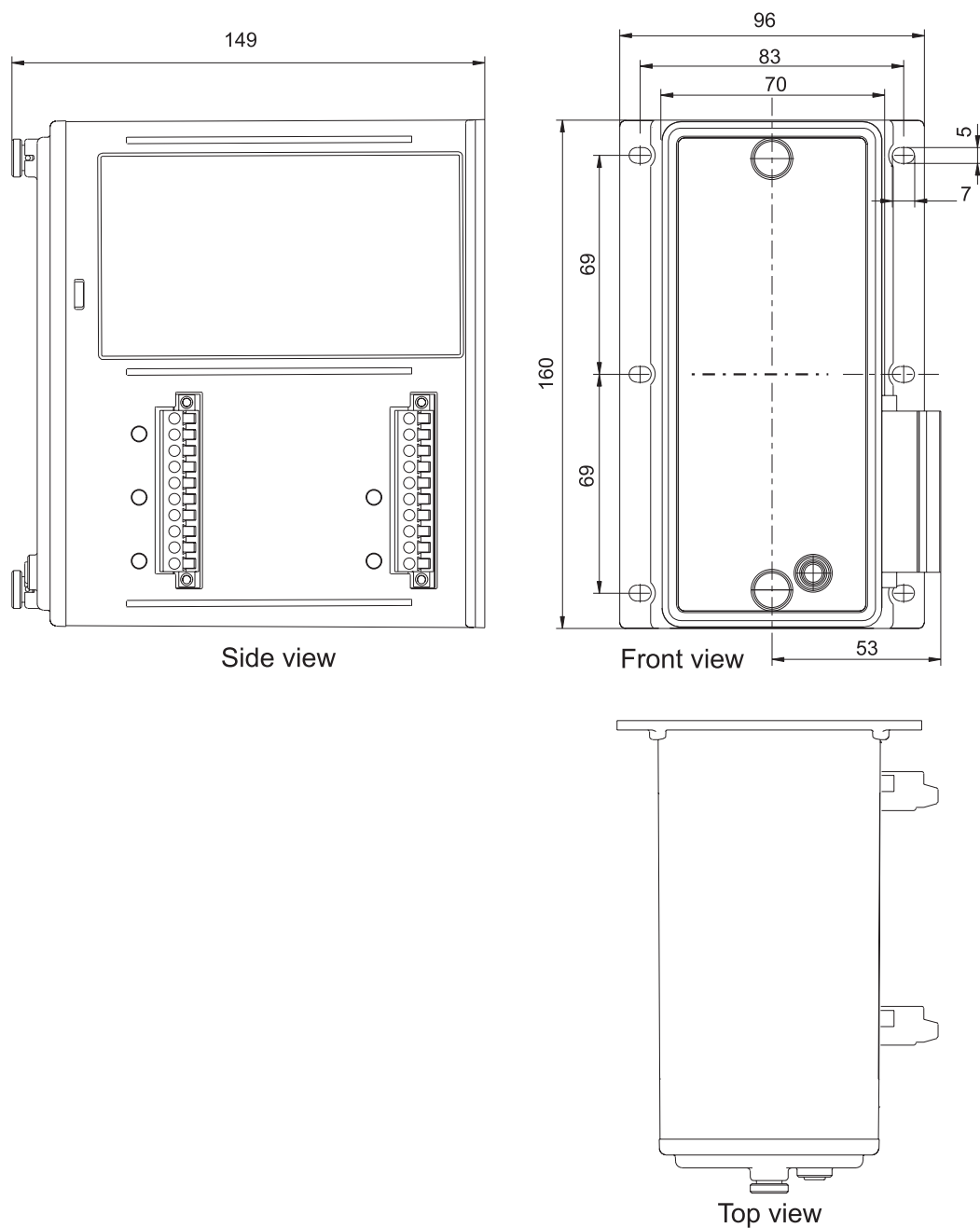

Fig. 5. Dimension and mounting details of Self-powered feeder protection REJ603 without HMI

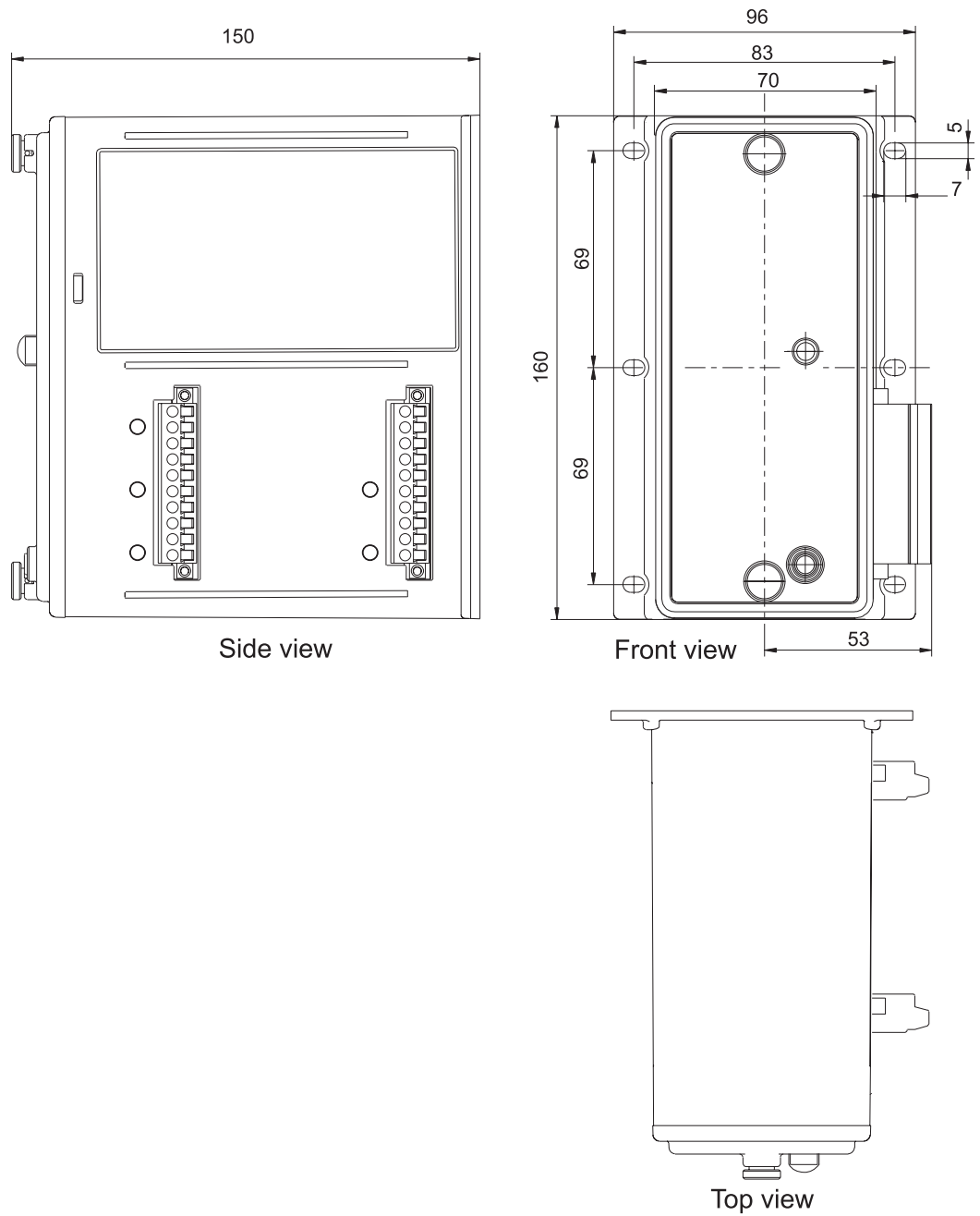

Fig. 6. Dimension and mounting details of Self-powered feeder protection REJ603 with HMI

11. Ordering details

Relay

Order Codes :

For REJ603 with HMI : REJ603BBB10NN31C

For REJ603 without HMI : REJ603BBB10NN3XC

For Add-on HMI kit : REJ603BNNNNNNBZA

Current Transformer

Note: The REJ603 requires specific ring CT's to be used for phase current measurement. It is not compatible with conventional 1 A/ 5 A CT's. The primary current setting range is adequately covered by following 4 variants of CT's .

CT type	Rated CT current range Is
REJ603-CT1	8 - 28A
REJ603-CT2	16 - 56 A
REJ603-CT3	32 - 112 A
REJ603-CT4	64 - 224 A
REJ603-CT5	128 - 448 A

For further technical information on current transformers and ordering information, please refer to the datasheet ref. 1YMA583791R0001-4.



Contact us

ABB Ltd, Distribution Automation

Maneja Works

Vadodara-390013, India

Phone: +91 265 2604386

Fax: +91 265 2638922

www.abb.com/substationautomation