

# REF542*plus*

## Manual Part 3:

## Installation and Commissioning

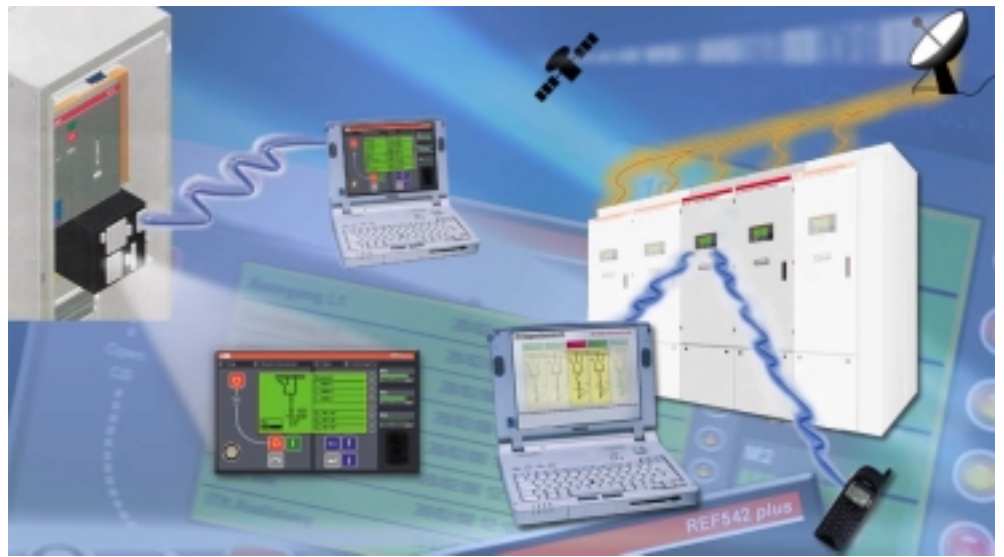

#### COPYRIGHT

WE RESERVE ALL RIGHTS TO THIS DOCUMENT, EVEN IN THE EVENT THAT A PATENT IS ISSUED AND A DIFFERENT COMMERCIAL PROPRIETARY RIGHT IS REGISTERED. IMPROPER USE, IN PARTICULAR REPRODUCTION AND DISSEMINATION TO THIRD PARTIES, IS NOT PERMITTED.

THIS DOCUMENT HAS BEEN CAREFULLY CHECKED. IF THE USER NEVERTHELESS DETECTS ANY ERRORS, HE IS ASKED TO NOTIFY US AS SOON AS POSSIBLE.

THE DATA CONTAINED IN THIS MANUAL IS INTENDED SOLELY FOR THE PRODUCT DESCRIPTION AND IS NOT TO BE DEEMED TO BE A STATEMENT OF GUARANTEED PROPERTIES. IN THE INTERESTS OF OUR CUSTOMERS, WE CONSTANTLY SEEK TO ENSURE THAT OUR PRODUCTS ARE DEVELOPED TO THE LATEST TECHNOLOGICAL STANDARDS.

AS A RESULT, IT IS POSSIBLE THAT THERE MAY BE SOME DIFFERENCES BETWEEN THE HARDWARE/SOFTWARE PRODUCT AND THIS INFORMATION PRODUCT.

## Table of Contents

<b>1</b>	<b>Introduction</b> .....	<b>6</b>
<b>2</b>	<b>Abbreviations and Definitions</b> .....	<b>7</b>
2.1	Abbreviations .....	7
2.2	Definitions .....	7
<b>3</b>	<b>Operation of the REF542<i>plus</i></b> .....	<b>9</b>
3.1	Operator's responsibilities .....	9
3.2	Guarantee Provisions .....	9
3.3	Safety Regulations .....	10
3.3.1	General safety notes .....	10
3.3.2	Specific safety information .....	11
<b>4</b>	<b>Mounting and Installation</b> .....	<b>12</b>
4.1	Unpacking .....	12
4.2	Mounting .....	12
4.2.1	Set-up Area and Required Environmental Conditions .....	14
4.2.2	Installation in LV panels .....	15
4.2.3	Connection diagrams .....	16
4.2.4	Wiring the REF542 <i>plus</i> .....	20
4.2.4.1	Checking the current transformer circuits .....	20
4.2.4.2	Check the voltage transformer circuits .....	21
4.2.4.3	Checking the auxiliary voltage .....	21
4.2.4.4	Check the tripping and signaling contacts .....	21
4.2.4.5	Check the binary inputs .....	21
4.2.5	Grounding of the REF542 <i>plus</i> .....	21
4.2.6	Typical examples of analog and binary connections .....	23
4.2.7	Connection Example of the REF542 <i>plus</i> Analog Inputs .....	24
<b>5</b>	<b>Commissioning</b> .....	<b>34</b>
5.1	Safety Information .....	34
5.2	Switching on the feeder .....	34
5.3	Test Equipment .....	34
5.4	Testing the interlock conditions, .....	34
5.5	Determining the transformer direction .....	35
5.5.1	Current transformer .....	35
5.5.2	Voltage transformer .....	36
5.5.3	Current sensor .....	36
5.5.4	Voltage sensor .....	37
5.6	Testing the measured value recording .....	37
5.7	Testing the protective functions .....	38
<b>6</b>	<b>Troubleshooting</b> .....	<b>39</b>

6.1	Safety Information.....	39
6.2	Required devices and facilities .....	39
6.2.1	Sinusoidal generator .....	39
6.2.2	Adjustable power supply .....	39
6.2.3	Personal computer .....	39
6.2.4	Tera Term Pro.....	39
6.2.5	Connection cables .....	40
6.2.5.1	RS232 cable.....	41
6.2.5.2	REF542 <i>plus</i> optical cable. ....	41
6.2.5.3	RS 485 Cable.....	41
6.3	Self test of the Central Unit.....	41
6.3.1	Behavior after cold start.....	42
6.3.2	Enter REF542 <i>plus</i> self test .....	43
6.3.2.1	RAM test .....	44
6.3.2.2	Program flash memory test.....	44
6.3.2.3	Configuration flash memory test .....	44
6.3.3	Calibration of the Analog Input.....	44
6.3.3.1	Transformer Input Board.....	45
6.3.3.2	Sensor Input Board .....	45
6.3.3.3	Mixed Input Board.....	46
6.3.3.4	Calibration procedure.....	46
6.4	Remote HMI self test .....	47
6.4.1	LCD test .....	49
6.4.1.1	Texts writing test .....	49
6.4.1.2	Graphic writing test .....	49
6.4.1.3	Back-light test.....	50
6.4.1.4	LCD contrast test .....	51
6.4.2	LEDs test.....	52
6.4.3	Keyboard test.....	52
6.4.4	E-Key test.....	53
6.4.5	Serial ports test .....	53
<b>7</b>	<b>Firmware upgrade.....</b>	<b>56</b>
7.1	Upgrade the Firmware of the Central Unit.....	56
7.2	RHMI firmware upgrade.....	56
<b>8</b>	<b>Decommissioning and Storage.....</b>	<b>57</b>
8.1	Decommissioning .....	57
8.2	Storage .....	57
<b>9</b>	<b>Technical data.....</b>	<b>58</b>
9.1	Analog input channels .....	58
9.1.1	With current and voltage transformer: .....	58
9.1.2	With current and voltage sensor .....	58
9.2	Binary inputs and outputs .....	59
9.2.1	With mechanical relays (1 BIO version 3).....	59
9.2.2	With static outputs (1 BIO version static).....	59

9.3	Interface.....	60
9.3.1	HMI Control Unit: .....	60
9.3.2	Central Unit: .....	60
9.4	Analog output board (optional) .....	60
9.5	Communication (optional).....	60
9.6	Power supply .....	60
9.6.1	Central Unit .....	60
9.6.2	RHMI Control Unit.....	60
9.7	Temperature range .....	61
9.8	Degree of protection .....	61
9.8.1	Central Unit .....	61
9.8.2	RHMI Control Unit.....	61
<b>10</b>	<b>Type Test .....</b>	<b>62</b>
10.1	Protection Function.....	62
10.2	Electro Magnetic Compatibility .....	66
10.2.1	Emission test.....	66
10.2.2	Immunity tests - enclosure port.....	67
10.2.3	Immunity tests - power supply port .....	68
10.2.4	Immunity tests - communication ports .....	69
10.2.4.1	Immunity tests - input and output ports.....	70
10.2.5	Immunity tests - functional earth port.....	71
10.3	Insulation Resistance.....	72
10.4	Mechanical Robustness.....	72
10.5	Climatic Conditions .....	72
<b>11</b>	<b>Connection Diagram.....</b>	<b>73</b>
11.1	REF542 <i>plus</i> with mechanical binary I/O.....	73
11.2	REF542 <i>plus</i> with solid state binary I/O.....	77

## 1 Introduction

This part of the manual describes the installation and commissioning of the REF542*plus* switchbay protection and control unit. The following section and its subsections contain information on:

Mounting and installation instructions

Commissioning

Decommissioning and storage

## 2 Abbreviations and Definitions

In the following abbreviations and definitions used in this manual are listed together.

### 2.1 Abbreviations

AIS	<b>A</b> ir <b>I</b> solated <b>S</b> witchgear
AR	<b>A</b> uto <b>R</b> eclosure
CT	<b>C</b> urrent <b>T</b> ransformer
DFT	<b>D</b> iscrete <b>F</b> ourier <b>T</b> ransformation
EMC	<b>E</b> lectro <b>M</b> agnetic <b>C</b> ompatibility
FUPLA	<b>F</b> unktionblock <b>P</b> rogramming <b>L</b> anguage also used as abbreviation for function plan or chart
GIS	<b>G</b> as <b>I</b> solated <b>S</b> witchgear
HMI	<b>H</b> uman <b>M</b> achine <b>I</b> nterface as control unit
LCD	<b>L</b> iquid <b>C</b> rystal <b>D</b> isplay
LED	<b>L</b> ight <b>E</b> mitting <b>D</b> iode
LAG	<b>L</b> on <b>A</b> pplication <b>G</b> uide
LV	<b>L</b> ow <b>V</b> oltage
MC	<b>M</b> icro <b>C</b> ontroller
PC	<b>P</b> ersonal <b>C</b> omputer
RHMI	<b>R</b> emote <b>H</b> uman <b>M</b> achine <b>I</b> nterface, the same meaning as HMI
VDEW	Association of German Utilities

### 2.2 Definitions

Notes and warnings on hazards are at the beginning of every section and also in the text. They are in a different font to distinguish them from normal text.

The safety warnings must be observed in all circumstances. If they are not observed, no guarantee claims will be accepted.

#### Note

A note indicates items that are significant in the specific context. A note may contain information on the interplay of various software components and appears as shown below.

Example:

---

Note

Please read this section completely for information on the various formats for safety notes.

**Hazard information level 1**

Level 1 hazard information indicates hazards affecting substations and devices. It should always be observed, because otherwise function interruptions or malfunctions may occur. An example is shown below:

---

**Caution** Do not make any changes to the FUPLA unless you are familiar with the REF542*plus* and the configuration software

**Hazard information level 2**

Level 2 hazard information indicates hazards affecting life and limb. It must be observed to avoid injury to the operator or other personnel.

Example:

---

**Warning!** Never attempt to remove the protection covers on the busbars by force.

## 3 Operation of the REF542*plus*

In this chapter you will find the following information:

Operator's responsibilities

Guarantee provisions

General safety notes

Special safety warnings that must always be observed when working with the REF542*plus*.

### 3.1 Operator's responsibilities

Please observe the following information for the operator:

The operating personnel for the REF542*plus* must have the appropriate qualifications for work on the unit.

Your operating personnel must be authorized to work with or on REF542*plus*. (E.g. switching authorization in substations)

Changes to the application as delivered may be made only by ABB personnel

For guarantee reasons, changes to the application as delivered made by the customer must always be approved by the appropriate ABB sales department

We recommend that only ABB personnel make adjustments to the unit. Once the guarantee has expired, the unit is opened at your own risk and is permitted after consultation with the ABB office that sold the unit.

### 3.2 Guarantee Provisions

The data provided in this documentation is intended solely to describe the product and must not be considered as assured properties. In the interest of users, we are continually striving to bring our products up to the latest state of the art in technology. For this reason there may be differences between the product and the product description and the manual.

If the instructions and recommendations of our documentation are observed, then, according to our experience, the best possible operational reliability of our products is guaranteed.

It is virtually impossible for comprehensive documentation to cover every possible event that may possibly occur when using technical devices and apparatus. We therefore request that our representatives or we be consulted in the event of any unusual incidents and in cases for which this Manual do not provide comprehensive information.

We explicitly refuse to accept any responsibility for all direct damages that occur as a result of erroneous usage of our devices, even if no special instructions on this are included in the manual.

The documentation has been carefully checked. If the user should find any defects in spite of this, we request that you inform us as quickly as possible.

We provide a 1 year guarantee for the functioning of the REF542*plus*.

The guarantee provisions are a component of the related contract documents.

Special arrangements may be made in consultation with the operator and will be specified in the contract documentation.

In general, all agreements, assurances, legal relationships and all ABB obligations arise from the current valid contract documentation, including any reference to the warranty provisions, which are not influenced by the content of this documentation.

ABB assumes no responsibility for damages resulting from improper use of REF542*plus*.

In the event of a guarantee claim, please contact the ABB office that sold the unit.

### 3.3 Safety Regulations

The safety notes in the following chapters represent only a general selection of the points that must be observed. Additional safety notes applicable to the actual content of the chapter can be found in the other specific parts of the manual.

Safety notes are either at the beginning of the section or directly at the relevant position in the text.

#### 3.3.1 General safety notes

##### Documentation

---

Note

The content of the documentation supplied with the device must be followed in all circumstances when the device is in operation.

##### Operating an electrical device

---

**Warning!**

**When any electrical device is being operated, specific parts of the device are subject to voltage. If safety warnings are not followed, hazards to personnel and property will result. Personal injury and damage to property may also occur.**

##### Safe Operation

---

Note

The device must be properly transported and stored to ensure fault-free and safe operation. In addition, commissioning, control, service and maintenance must be properly and thoroughly conducted.

### 3.3.2 Specific safety information

#### Five safety rules

**Warning!** The five safety rules according the so called "VBG4 Electrical Substations and Equipment" must be observed in all circumstances for personal safety:

1. Isolate the system before beginning work.
2. Secure against reactivation.
3. Ensure that there is no voltage.
4. Ground and short circuit.
5. Cover or shut out neighboring parts under power.

#### Additional safety standards

**Warning!** The following safety standards must be observed in all circumstances:

1. IEC 60255 for protection relays in high-voltage substations
2. DIN 57627 plug connections

#### Working on and operating the device

---

Note

Only qualified personnel may work on and operate the device.

Qualified personnel are:

Entrusted with the setup, installation, commissioning and operation of the device and the system in which it is installed.

Qualified and authorized to conduct switching operations in accordance with the standards of safety engineering. This specifically includes switching on and off, isolating, grounding and signage.

Trained in safety engineering standards and are familiar with the maintenance and use of safety equipment.

Trained in first aid.

## 4 Mounting and Installation

In this chapter you will find information:

on what to do first on delivery of the REF542*plus*

the requirements for the installation location and the environmental conditions,

how to set up the REF542*plus* and integrate it into the bay and

how to check the wiring to run the commissioning process.

### 4.1 Unpacking

The REF542 bay control and protection unit does not require special shipping protection. The packaging is adapted for the shipping type and destination. Please proceed as follows:

Visually inspect the unit and the packaging when unpacking it.

Any shipping damage found in the packaging or the unit should be reported immediately to the last shipper, who should be informed in writing of liability for the damage.

Check the delivery for completeness using the order documentation.

If there is anything missing or any discrepancies with the order documentation, contact the ABB sales office immediately.

Mount the unit as described in the following section. If the unit is not for immediate use, store it in a suitable place in its original packaging.

### 4.2 Mounting

The REF542 *plus* consists of two parts, a Central Unit and a separate Human Machine Interface (HMI) as the Control Unit. The Central Unit contains the power supply, processor and analog and binary Input and Output (I/O) modules, as well as optional modules for supplementary functions. The HMI Control Unit is a stand-alone unit with its own power supply. It can be installed on the Low Voltage (LV) compartment door or in a dedicated compartment close to the Central Unit. The HMI is normally used to set the protection parameters and to locally operate the switching devices in the switchbay. An isolated and shielded twisted pair according to the RS485 standard interface shall be used for the connection of the HMI as the Control unit to the Central Unit.

The figures below show the dimensions of the HMI Control Unit and Central Unit.

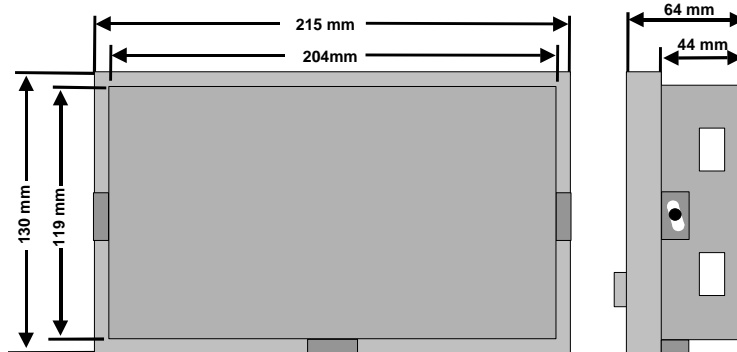

**Figure 1:** Dimension of the HMI Control Unit

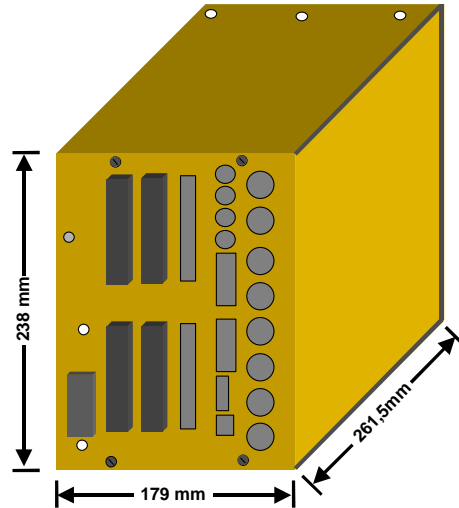

**Figure 2:** Dimension of the Central Unit case, standard version

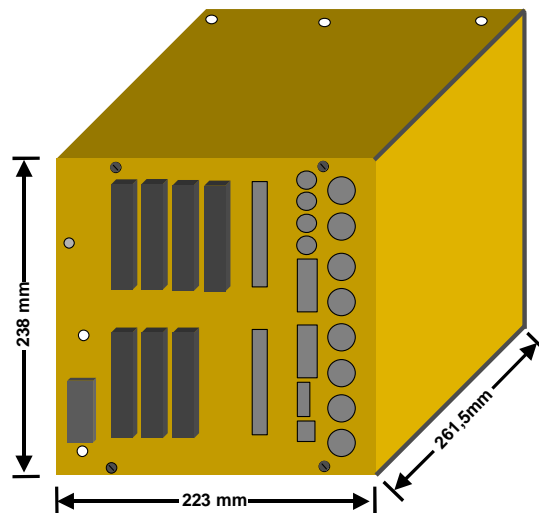

**Figure 3:** Dimension of the Central Unit case, wide version

The following table shows the data relevant for mounting.

**Table 1:** Relevant data for mounting

Design		
Weight	Standard version: ... kg	depending on equipment
	Wide version: ... kg	depending on equipment
Installation type	HMI: semiflush on the LV door	
	Central unit: in the LV compartment	
Dimensions	185 x 244.8 x 261.5 mm (W x H x D)	Standard version
	229 x 244.8 x 261.5 mm (W x H x D)	Wide version
Panel cutout	206 x 121 mm (W x H)	

#### 4.2.1 Set-up Area and Required Environmental Conditions

Please note the following information regarding the set-up area:

Allow sufficient space for access to the. The connections must be easily accessible.

Access to the Central Unit in the LV compartment must be easy for the following reasons:

to replace the unit,

to expand the unit,

to replace specific electronic equipment boards and

to replace specific modules if necessary.

Because the unit is sensitive to non-permitted severe environmental conditions, please observe the following:

The set-up area must be free of excessive air contamination (dust, aggressive substances...).

The natural air circulation around the unit must be free.

The set-up area must maintain the specified environmental conditions

## 4.2.2 Installation in LV panels



**Figure 4:** REF542*plus* installed in gas-insulated switchgears (GIS)



**Figure 5:** REF542*plus* installed in air-insulated switchgears (AIS)



**Figure 6:** Example of mounting of the Central Unit in the LV compartment and the HMI on the door

### 4.2.3 Connection diagrams

#### Connector Plate

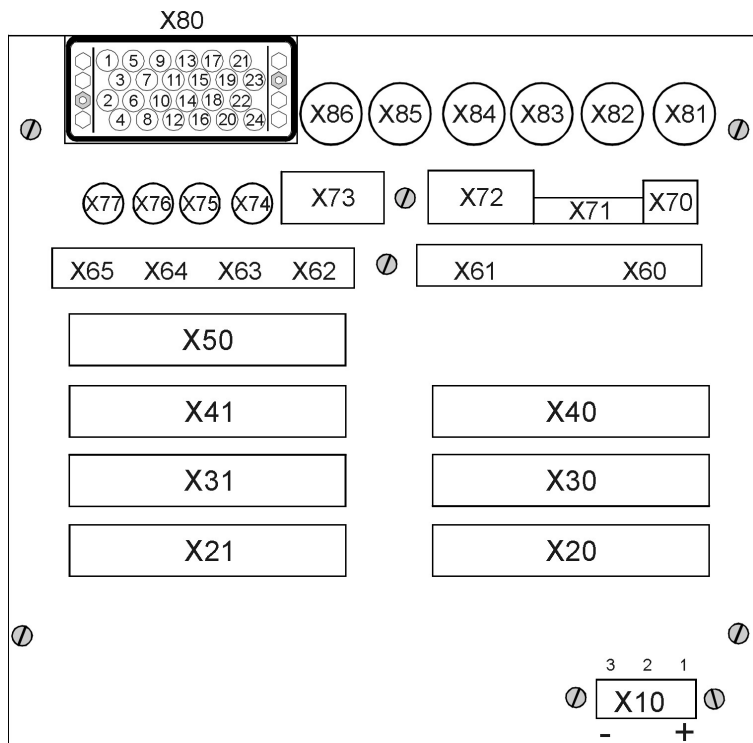

**Figure 1:** REF542plus connector plate for the wide case mixed analog input version

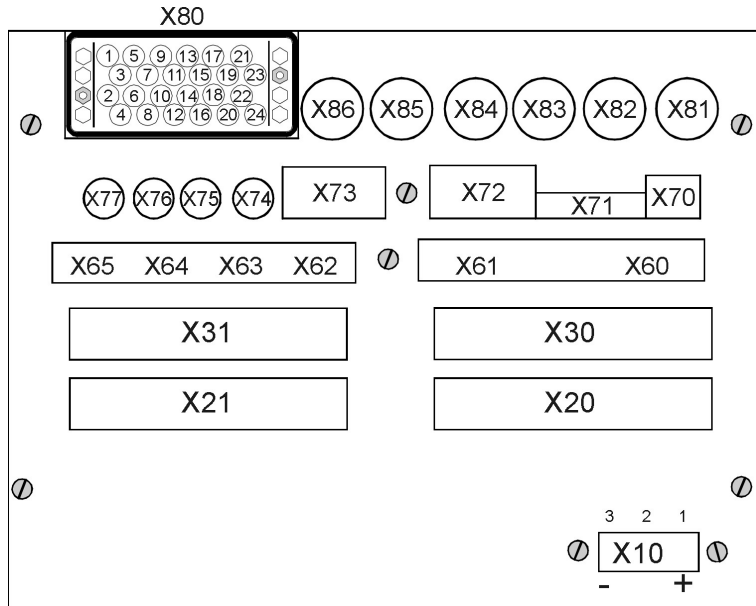

Figure 2: REF542*plus* connector plate for the short case mixed analog input version

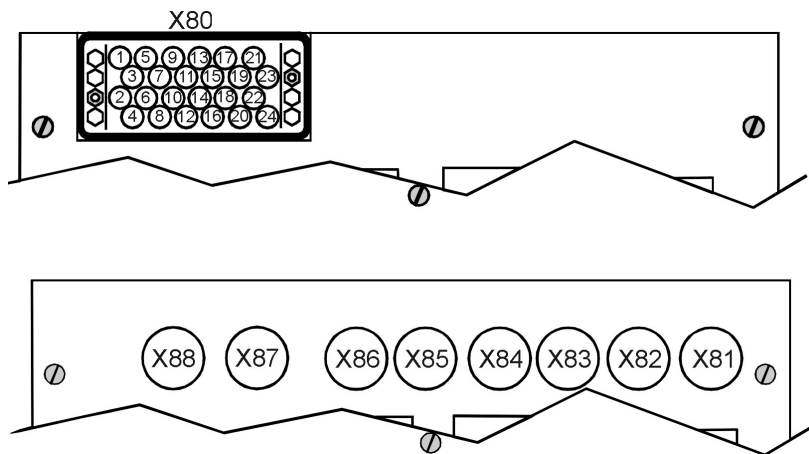

Figure 3: REF542*plus* connector plate for analog input with transformers or with sensors

**Table 2:** Connectors on Central Unit

Connector	Descriptions	Type of connector plug
X10	Auxiliary voltage for power supply	3 pin Weidmueller female BLAT3BSNOR + fixing set SLABB2RORSET
X20	Binary Inputs of the 1 <sup>st</sup> BIO	Harting 09 06 000 9474, DIN 41612
X21	Binary outputs of the 1 <sup>st</sup> BIO	Harting 09 06 000 9474, DIN 41612
X30	Binary Inputs of the 2 <sup>nd</sup> BIO	Harting 09 06 000 9474, DIN 41612
X31	Binary outputs of the 2 <sup>nd</sup> BIO	Harting 09 06 000 9474, DIN 41612
X40	Binary Inputs of the 3 <sup>rd</sup> BIO	Harting 09 06 000 9474, DIN 41612
X41	Binary outputs of the 3 <sup>rd</sup> BIO	Harting 09 06 000 9474, DIN 41612
X50	Analog output	Harting 09 06 000 9474, DIN 41612
X70	Ethernet interface (full version)	Not available yet
X71	CAN interface (full version)	Not available yet
X72	RS232 interface	9 pin D-sub connector male
X73	RS485 interface	9 pin D-sub connector male
X74	IRIG-B interface (full version)	Not available yet
X75	Fast I/O inputs (full version)	Not available yet
X76	Fast I/O outputs (full version)	Not available yet
X77	Fast I/O inputs (full version)	Not available yet
X80	Analog inputs (from CT and/or VT)	Connector kit Compel c/w 24 contacts - Short version code 350.040.902 - Long version code 350.040.903 Crimp any single contact with hand tool No 350.048.011
X81..88	Analog input (sensor channel 1..8)	BNC Twin Cam CPE 23.717.140-0333

**Table 3:** Connectors on Central Unit for SPABUS connection, electrical RS232 (modified)

Connector	Descriptions	Type of connector plug
X60	RS232 (modified)	9 pin D-sub connector male (z-modem)

Note

The RS232 connector, modified and galvanic isolated, can be applied to connect to a LON/SPA gateway.

**Table 4:** Connectors on Central Unit for SPABUS connection, plastic fiber optical cable

Connector	Descriptions	Type of connector plug
X60	TX (optical interface)	Snap in HP HFBR 4501 (gray)
X61	RX (optical interface)	Snap in HP HFBR 4511 (blue)

**Caution**

**The cable length for SPABUS connection with plastic fiber optical cable should not exceed 30 m**

**Table 5:** Connectors on Central Unit for SPABUS connection, glass fiber optical cable

Connector	Descriptions	Type of connector plug
X60	TX (optical interface)	ST plug HITRONIC ST-125
X61	RX (optical interface)	ST plug HITRONIC ST-125

**Caution** The cable length for SPABUS connection with glass fiber optical cable should not exceed 1000 m

**Table 6:** Connectors on Central Unit for LON per LAG 1.4 respectively IEC 60870-5-103

Connector	Descriptions	Type of connector plug
X60	TX (optical interface)	ST plug HITRONIC ST-125
X61	RX (optical interface)	ST plug HITRONIC ST-125

**Caution** The cable length for LON (per LAG 1.4) connection with glass fiber optical cable should not exceed 2000 m

**Table 7:** Connectors on Central Unit for MODBUS RTU, electrical RS485

Connector	Descriptions	Type of connector plug
X60	RS485 channel 1	2pin Weidmueller BLAT2BSNOR
X61	RS485 channel 2	2pin Weidmueller BLAT2BSNOR

**Caution** To connect to the upper level automation system with MODBUS RTU a twisted pair cable shall be used. If the cable is shielded, connect only one side of the shield to the earth screw of the housing. The maximum baud rate is 115000 bit/s. The cable length should not exceed 130 m

**Table 8:** Connectors on Central Unit for MODBUS, glass fiber optical cable

Connector	Descriptions	Type of connector plug
X62	RX channel 1 (optical interface)	ST plug HP type HFBR *XS*
X63	TX channel 1 (optical interface)	ST plug HP type HFBR *XS*
X64	RX channel 2 (optical interface)	ST plug HP type HFBR *XS*
X65	TX channel 2 (optical interface)	ST plug HP type HFBR *XS*

**Caution** The maximum baud rate is 115000 bit/s with glass fiber optical cable. Its length should not exceed 2000 m

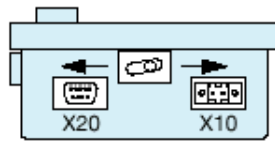

**Figure 7:** Power Supply and communication connection for HMI Control Unit

**Table 9:** Connectors on HMI Control Unit

Connector	Descriptions	Type
X10	Auxiliary voltage for power supply	2 pin Weidmueller BLAT2BSNOR
X20	RS485 interface to Central Unit	9 pin male D-sub connector

## 4.2.4 Wiring the REF542*plus*

Follow the bay documentation supplied for the wiring.

In conclusion, the checks described in the following paragraphs can be done to ensure that the wiring is correctly installed.

### 4.2.4.1 Checking the current transformer circuits

To check that the current transformer and the current transformer circuits are wired correctly, run the following checks:

#### Polarity check

The polarity check (as close as possible to the REF542*plus*) is used to check the current circuit and also the installation position and the polarity of the transducer. The polarity of the transducers to one another can also be checked with load current.

#### Current feed with heavy current source (primary test instrument).

The current feed provides information on the transducer transformation and the correct wiring to the REF542*plus*. The power supply should be per conductor and run from conductor to conductor in each case. All line currents and the residual current should be checked here.

The transducer transformation can also be checked with load current.

#### Recording the magnetizing characteristic

Recording the magnetizing characteristic ensures that the REF542*plus* is connected to a protective core and not to a measuring core.

#### Checking the transducer circuit ground

Every independent current circuit may be grounded at only one point to prevent balancing currents resulting from potential differences.

#### Check the grounding of the cable current transformer (when used)

If the neutral current is measured by a cable current transformer, the cable shielding should first be returned through the cable current transformer before connecting it to the ground.

This enables weak ground faults currents that flow along the cable sheath to dissipate. In this way, they will not be incorrectly measured at their own relay feeder. The following shows another view of the cable current transformer grounding.

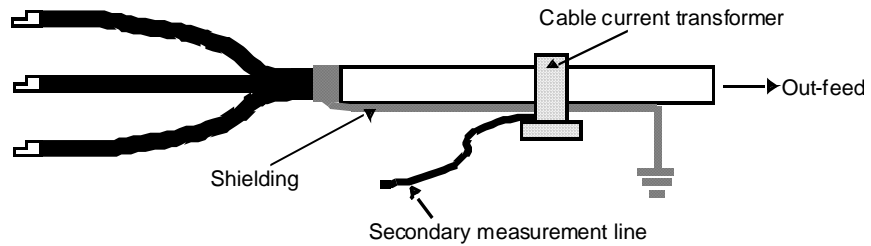

**Figure 8:** Grounding of a cable current transformer

#### 4.2.4.2 Check the voltage transformer circuits

To check that the voltage transformer and the voltage transformer circuits are wired correctly, run the following checks:

Polarity check

Wiring check

Check the transformer circuit grounding

Check the voltage transformer for neutral point-ground voltage (when used).

To measure ground faults please proceed as follows: The voltage is referred to as neutral point-ground voltage of a ground fault measurement when it occurs with a metallic ground fault in the network between terminals "e" and "n" of the open delta winding.

In the event of a metallic ground fault in phase L1, the external phase-to-neutral voltages occur in phases L2 and L3 instead of the conductor-ground voltages. They are added geometrically and yield three times the amplitude between terminals "e" and "n".

#### 4.2.4.3 Checking the auxiliary voltage

The auxiliary voltage must be in the tolerance range of the power supply module and have the proper polarity under all operating conditions.

#### 4.2.4.4 Check the tripping and signaling contacts

Conduct this check as shown in the bay documentation.

#### 4.2.4.5 Check the binary inputs

Check the polarity and the voltage value of the binary inputs on the REF542 in accordance with the technical data of the binary inputs.

### 4.2.5 Grounding of the REF542*plus*

As can be seen in the following figure, the power supply board at connector X10 must be grounded to the housing. Therefore the middle pin must be connected to the grounding point in the LV compartment. Beside that, the shielding of the cable connection to the HMI control unit must also be connected to ground respectively to the housing.

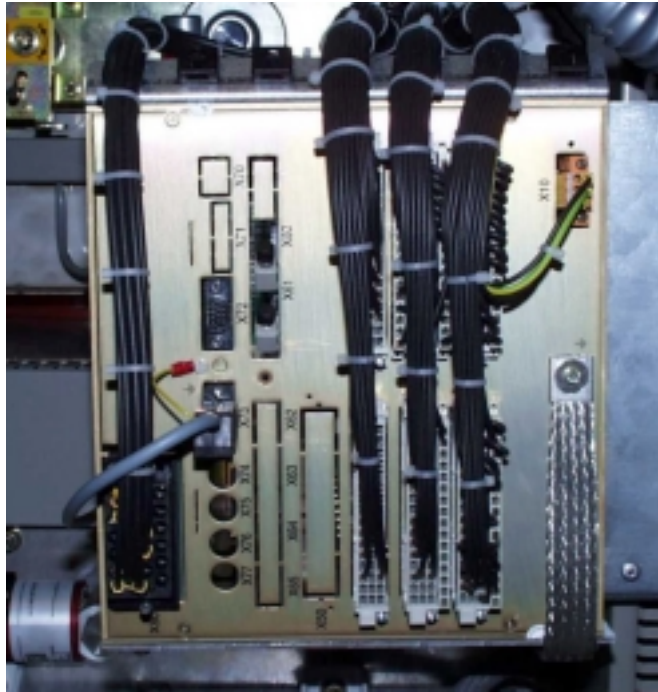

**Figure 4:** Grounding of the REF542*plus* Central Unit housing

To ensure the EMC (**E**lectro **M**agnetic **C**ompatibility) the housing must be grounded by a low impedance galvanic connection to the grounding system. As it is shown in the figure, an appropriate cable connection, which is fixed from a specific screw on the housing to the grounding system in the LV compartment, must be foreseen. That is why an interweaving cable is used for the grounding connection. If, due to the installation construction, the low impedance connection from the housing to the grounding system is already given, the additional grounding connection by the interweaving cable can be abstain from.

The housing of the HMI Local Control Unit must also be grounded too. As can be seen in the next figure, a specific grounding cable is to be connected from the housing of the HMI Local Control Unit to the grounding system in the LV compartment.



**Figure 5:** Grounding of the REF542*plus* HMI Local Control Unit

#### 4.2.6 Typical examples of analog and binary connections

The following pages show examples for wiring analog inputs (measuring inputs) on the REF542*plus* with sensors or transducers, binary I/Os and analog output boards. Typical examples of usage in practice will be shown here. The following symbols are used in the circuit diagrams:

**Table 10:** Graphical symbols for electric diagram (IEC 60617)

Symbol	Legend	Symbol	Legend
	Energy flow from the bus bar		Ring core current transformer
	Energy flow towards the bus bar		Make contact
	Mechanical, pneumatic or hydraulic connection (link)		Break contact
	Earth, ground		Change-over break before make contact
	Conductors in a screened cable		Position switch, break contact
	Twisted conductors		Circuit breaker
	Connection of conductors		Disconnector
	Plug and socket male and female)		Operating device

Symbol	Legend	Symbol	Legend
	Resistor with one fixed tapping		Fuse
	Current transformer		Sensing element
	Three-phase transformer		Current sensing element
	Voltage transformer		Optical fibre cable

#### 4.2.7 Connection Example of the REF542*plus* Analog Inputs

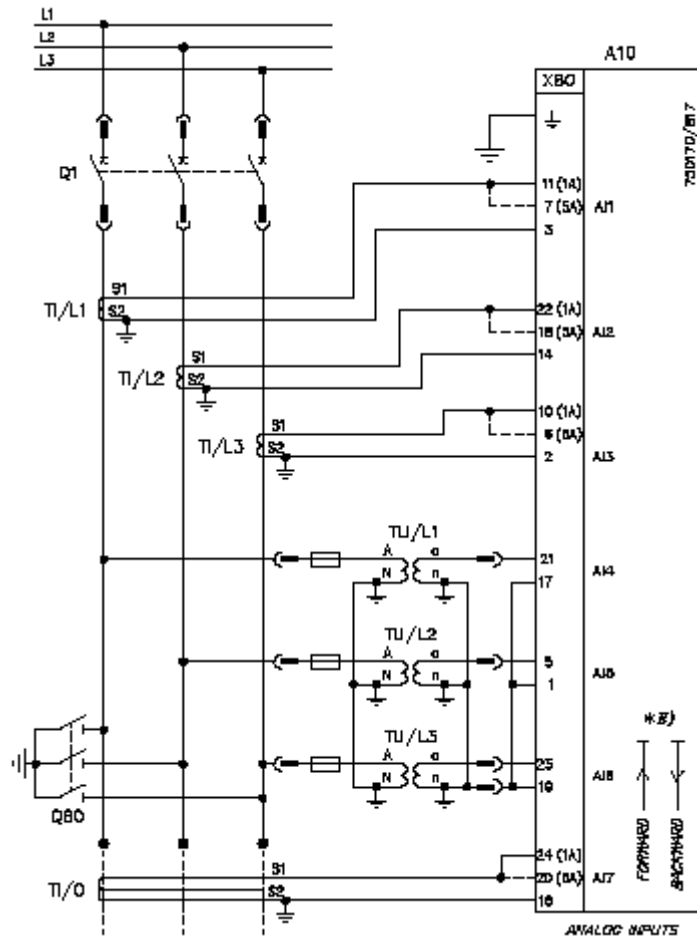

Figure 6: Example of connection diagram for incoming or outgoing bays with transformers

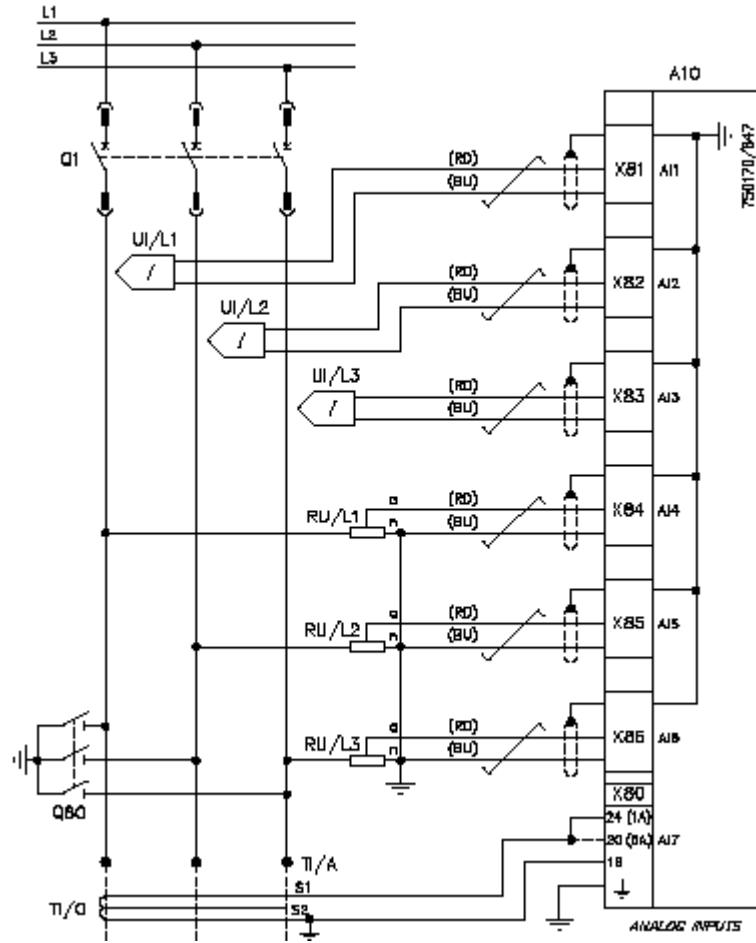

Figure 7: Example of connection diagram for incoming or outgoing bays with sensors

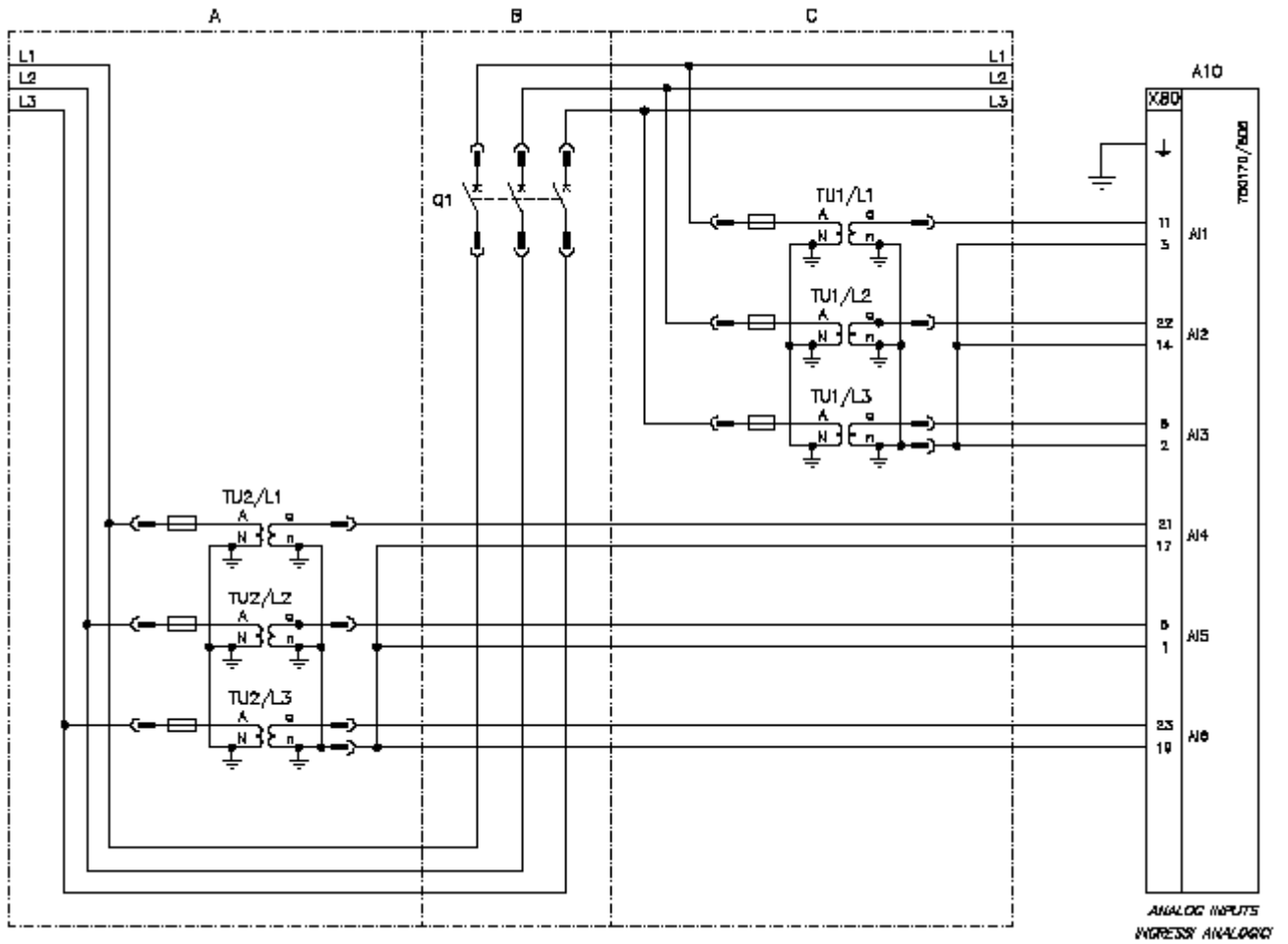

Figure 8: Example of connection diagram for bus-tie and measuring bays with transformers

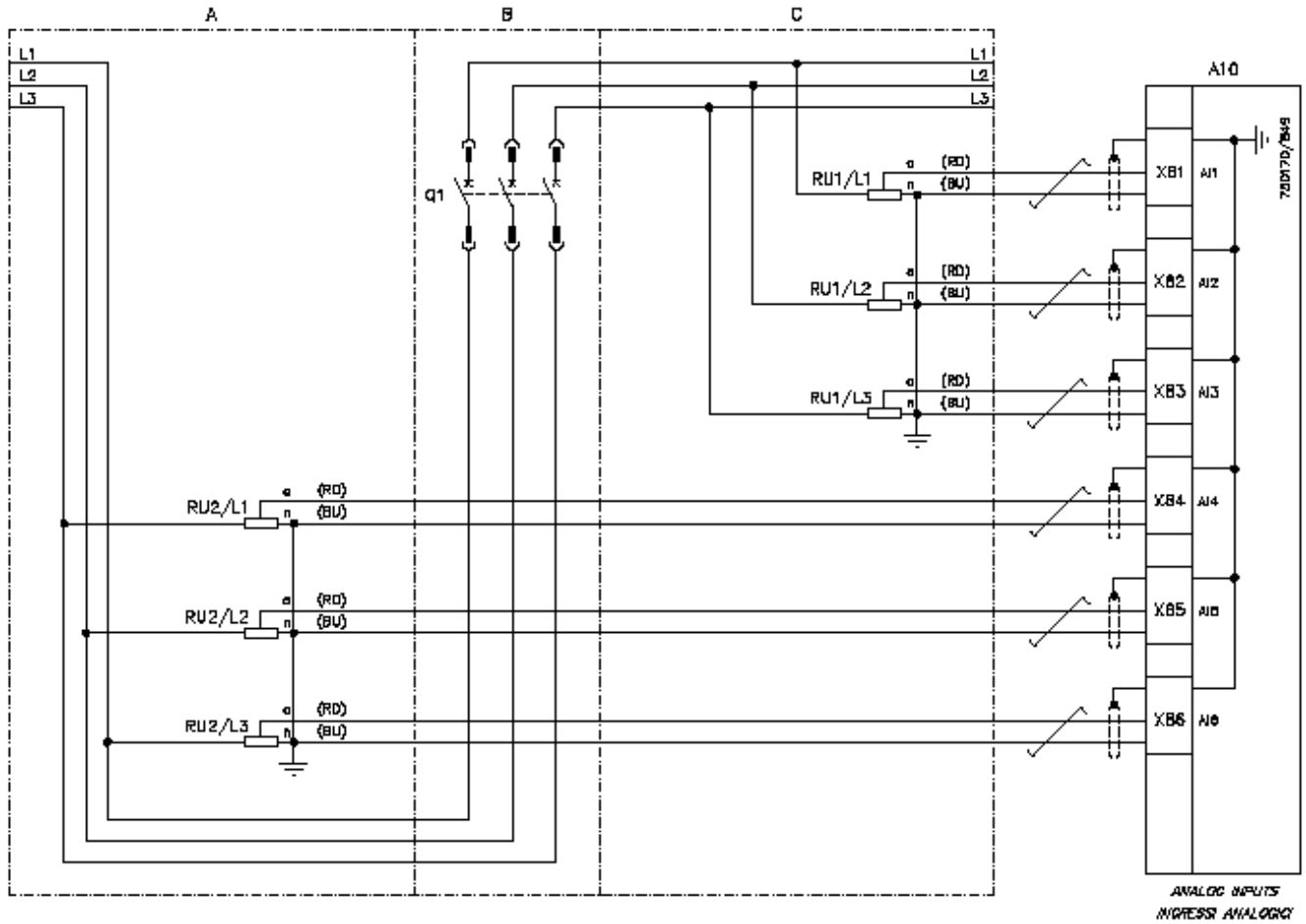
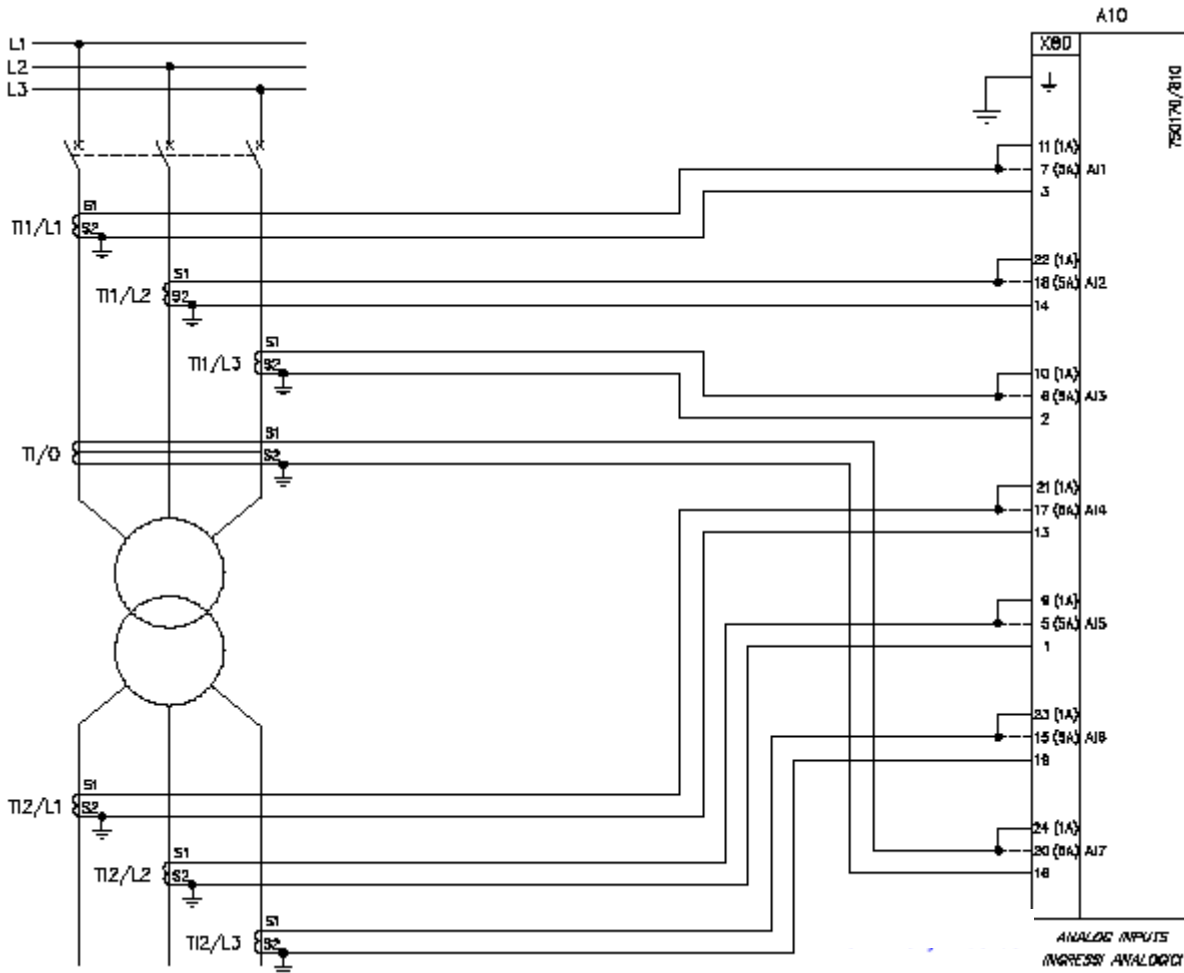

Figure 9: Example of connection diagram for bus-tie and measuring bays with sensors

**Caution** Due to accuracy requirements the length of the cable connection to the sensors in other bay respectively panels should be less than 7 m



**Figure 10:** Example of connection diagram for the transformer differential protection with transformers

**Caution** Due to accuracy requirements the length of the cable connection to the sensors in other bay respectively panels should be less than 7 m

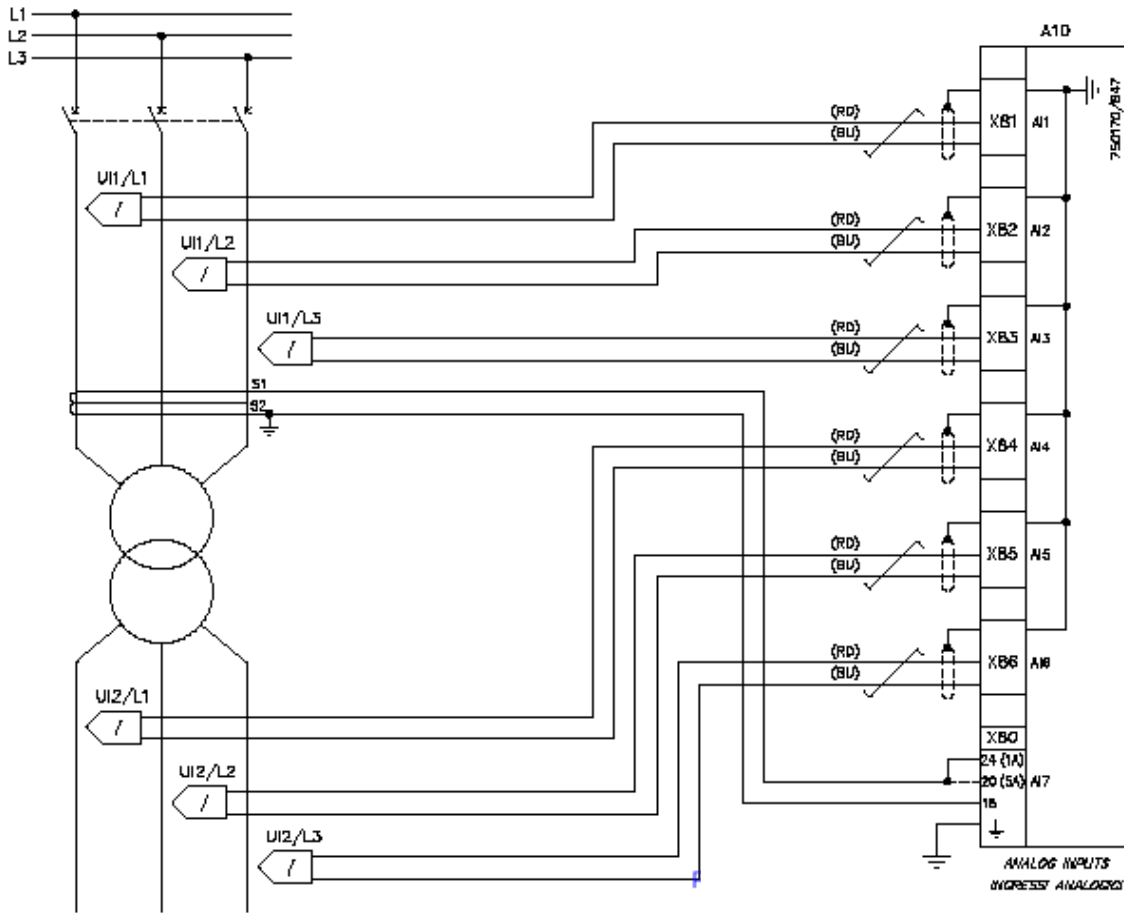

Figure 11: Example of connection diagram for the transformer differential protection with sensors

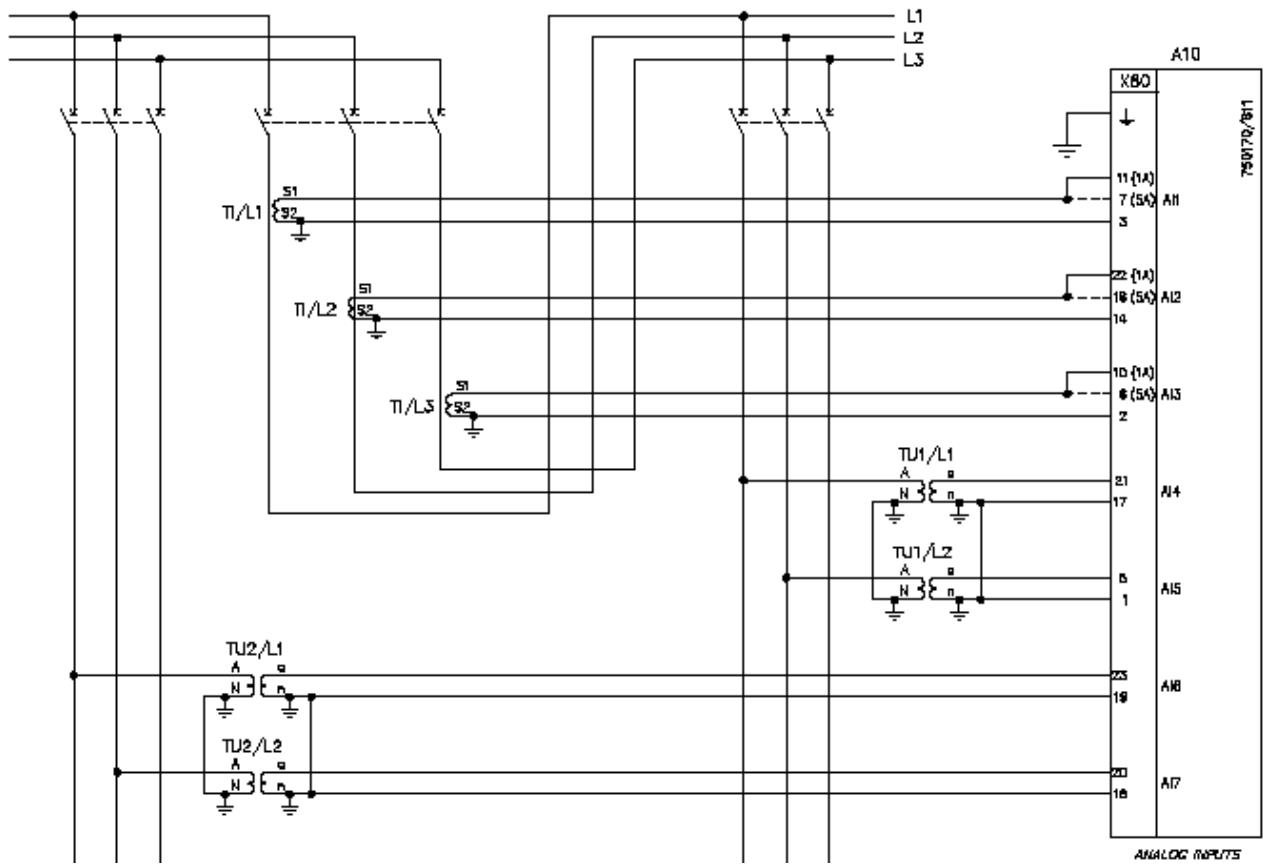
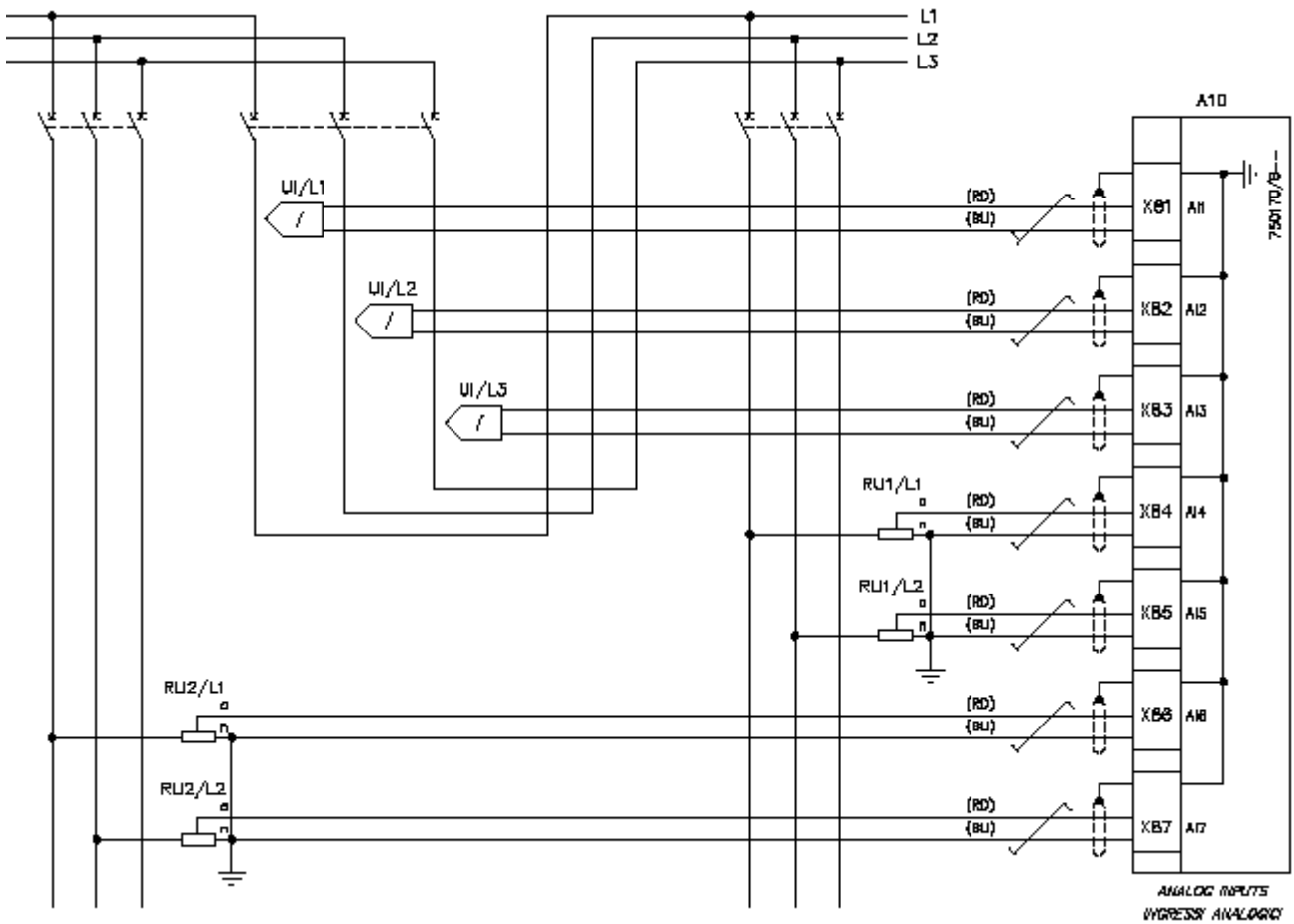

Figure 12: Example of connection diagram for the synchronism check with transformers



**Figure 13:** Example of connection diagram for the synchronism check with sensors

**Caution** Due to accuracy requirements the length of the cable connection to the sensors in other bay respectively panels should be less than 7 m

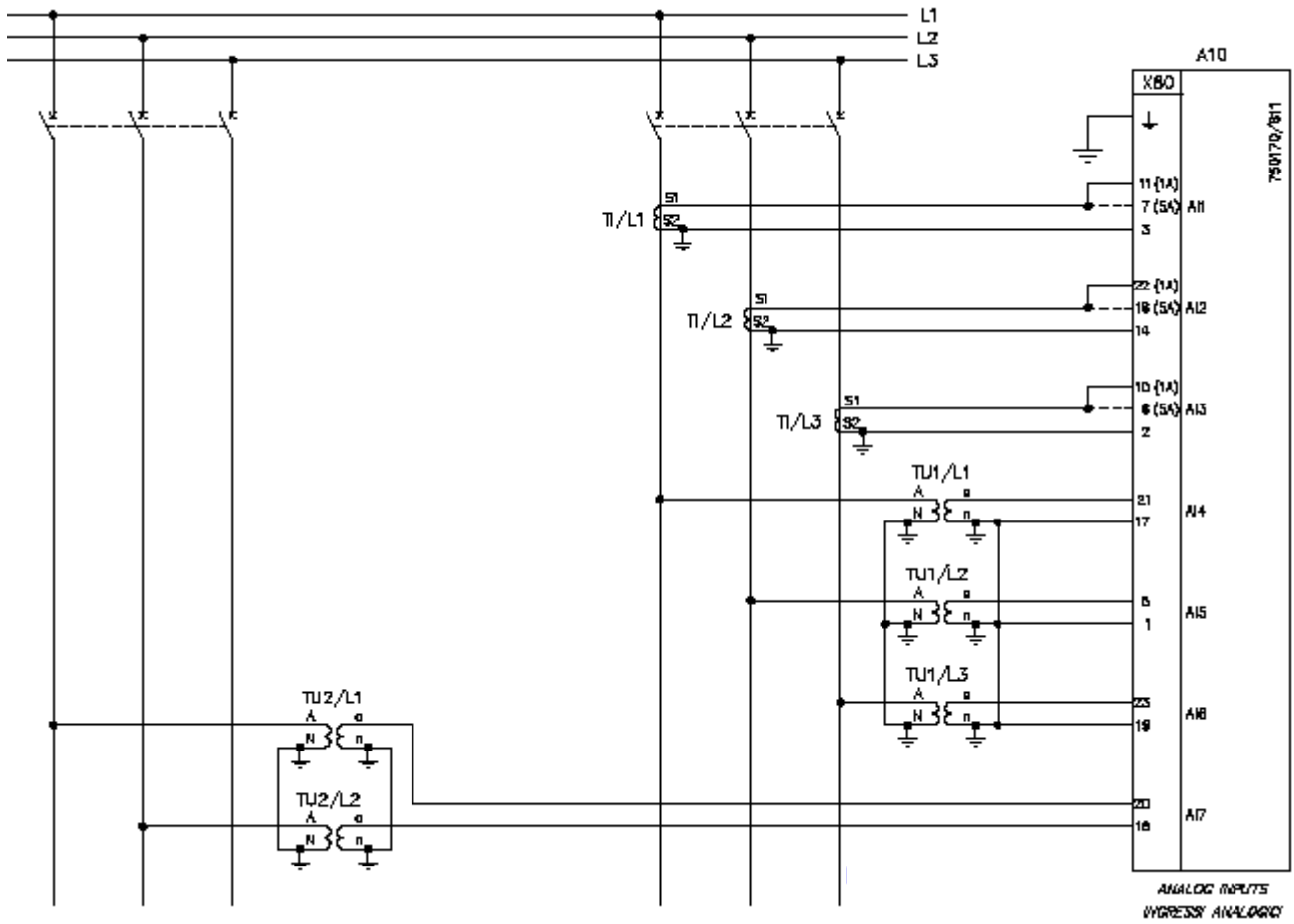

Figure 14: Example of connection diagram for the synchronism check with transformers

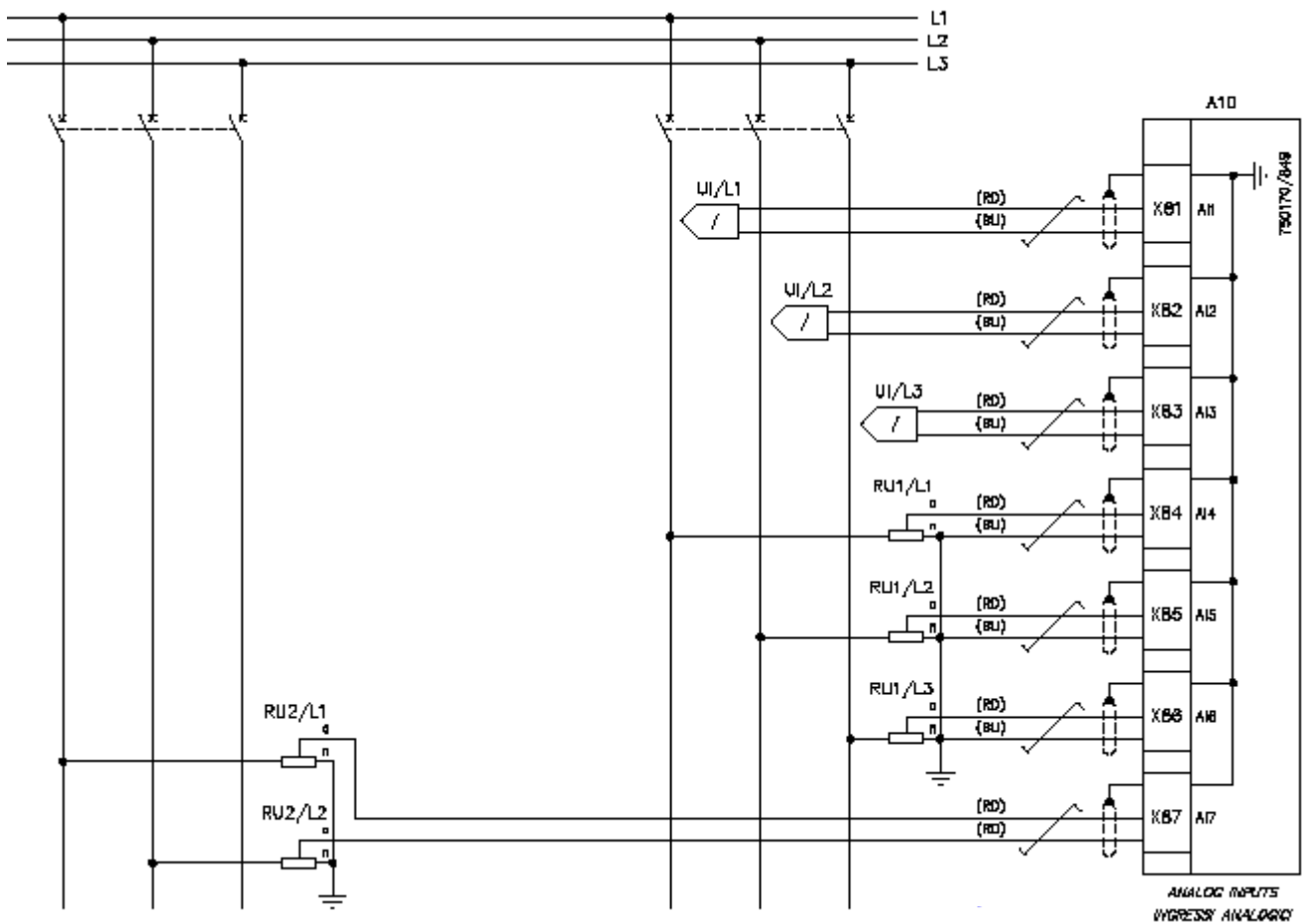

Figure 15: Example of connection diagram for the synchronism check with sensors

**Caution** Due to accuracy requirements the length of the cable connection to the sensors in other bay respectively panels should be less than 7 m

## 5 Commissioning

The following sections with their subsections contain information on:

- The devices and facilities required for the commissioning inspection.
- The required procedure for the commissioning inspection; For example, depending on the components to be tested: Protection, interlock conditions, communications, measured value recording and determining the direction.

### 5.1 Safety Information

The devices, adapters and procedures described are only examples. Experience and safety in handling the various devices is a requirement.

### 5.2 Switching on the feeder

---

**Caution** Before switching on the feeder check that the REF542*plus* is fully functional in the corresponding bay. Pay particular attention to the protective functions and the interlocking!

### 5.3 Test Equipment

The most important device for the commissioning of the REF542*plus* is an appropriate relay test equipment. The test equipment should have a three phase current and voltage system. Also the simulation of current and voltage sensors by the test equipment shall also be possible. For example a test equipment manufactured by KOCOS in Korbach/Germany can be used.

### 5.4 Testing the interlock conditions,

This test is intended to check the interlocking of the switchgear that the user wants and is required. The two types of interlocking must be taken into account here:

Bay-level interlocking of specific switchgear and

Station-level interlocking of the bay versus other bays.

The interlock conditions for the bay under test can be found in the order documentation. The interlock conditions specified by the user can be found there.

All possible circumstances must be checked.

## 5.5 Determining the transformer direction

The connection of the measuring inputs and the correct polarity of the current and voltage transformers or sensors is very important for distance, comparison and directional functions.

In addition to testing the polarity, the transformation ratio and the magnetizing characteristic, the wiring of the transformers/sensors must also be checked during these test.

### 5.5.1 Current transformer

The transformers must have a positive winding.

This can be easily checked with a 9 V battery and an analog DC voltmeter. If the primary coil of the current transformer is connected to the battery, the analog voltmeter connected on the secondary side must show positive. When the battery is disconnected, the voltmeter must measure a negative impulse.

The positive terminal of the battery must be connected to P1 of the primary coil and the positive input of the voltmeter to s1 for this test. The same applies for the negative terminal at P2 of the primary coil and the voltmeter negative input at s2 of the secondary coil.

The test setup for checking the direction of a core is shown in the following figure.

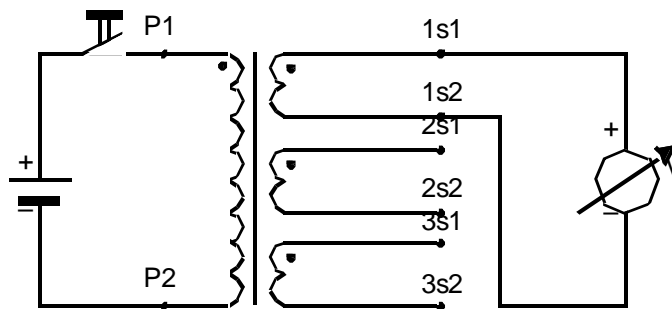

**Figure 16:** Setup for the polarity test of current transformers

This polarity check, also referred to as patch test, must be run for every core. To guarantee correct operation even with a multi core current transformer with different cores such as protection and measuring cores, it is recommended that the magnetizing characteristic (hysteresis) be recorded. A Variac with appropriately high voltage is connected to the secondary terminals. The flowing current is measured while the output voltage is rising. The characteristic of the measured values, voltage over current, yields the magnetizing characteristic of the core, which can then be compared with the manufacturer's data.

The transformation ratio of the current transformer cores is checked with a special primary current feed device. The feed device is primarily connected to the current transformer and the secondary value is measured at the secondary terminals of the transformer or at the protective cabinet with an ampere meter.

### 5.5.2 Voltage transformer

The same polarity test or patch test is run with voltage transformers. The difference is that the battery is connected to the secondary side and the analog DC test instrument to the primary coil of the voltage transformer.

The test setup for checking a core is shown in the following figure.

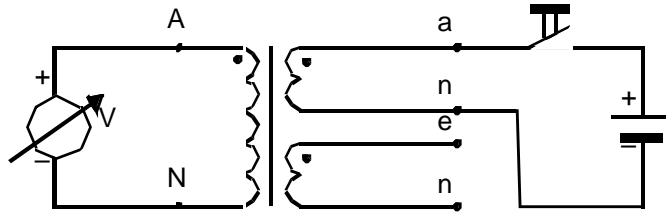

**Figure 17:** Polarity test of voltage transformers

Every core must be tested here.

If the Variac described in the current transformer section for recording the magnetizing characteristic has a sufficiently high output voltage (e.g. 500 V), it can also be used to run a qualitative test of the voltage transformer transformation ratio. The Variac voltage is applied to the primary side of the voltage transformer and a voltmeter is used to measure the secondary voltage at the corresponding transformer or protective cabinet terminals.

### 5.5.3 Current sensor

Because the current sensor, the Rogowski coil, is an air-core coil, it must be subjected to the same polarity test as the current transformers.

The test design is shown in the following diagram. A higher voltage value may be required for the battery.

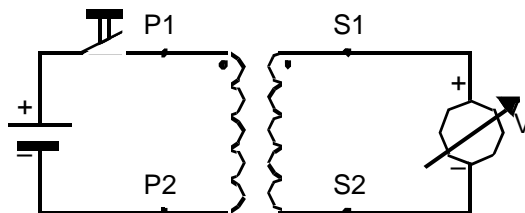
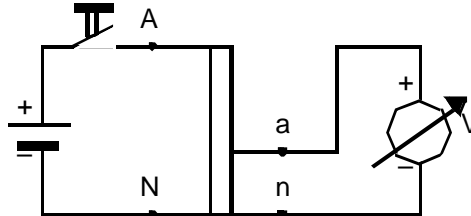

**Figure 18:** Polarity test of current sensors (Rogowski coil)

The transformation ratio is tested exactly as with a current transformer. The display in the REF542 protection and control unit can also be checked at the same time. It is not necessary to record a magnetizing characteristic with the Rogowski coil, because it is an air-core coil with no saturation characteristics.

### 5.5.4 Voltage sensor

The polarity of the voltage sensor, which is a resistive precision voltage divider, is checked as shown in the following diagram. The correct polarity of the voltage is measured by applying an appropriate DC voltage (e.g. 24V/DC) to the secondary terminals. The auxiliary voltage source can also be used if the transformation ratio is very high. The transformation ratio of the resistive divider is checked at the same time.



**Figure 19:** Polarity test of voltage sensors (resistive splitter)

## 5.6 Testing the measured value recording

Proper functioning of the transformers and sensors is important for proper functioning of the REF542*plus*. The measured-value processing of the unit and the set rated values must be tested for this reason.

The phase currents and phase voltages must be taken as measured input quantities. All other measured values are quantities derived from them.

Test as follows:

Check whether the set rated values match the rated values required by the user (in the order documentation).

If necessary, load the application into the PC from the REF542*plus*.

Select the menu item `Main Menu/Settings/Connections/Analog Inputs` in the configuration program. The rated values are shown in the dialog window that appears and, if necessary, changed.

Test the wiring of the transformers or sensors

Disconnect the transducers or sensors from the REF542*plus*.

The current transformers must be short-circuited, combination sensors disconnected.

Connect the test set to the REF542*plus*. The relevant current and voltage signals are applied to the analog inputs.

Set the required rated values on the test set

**Table 11:** Rated values of the current and voltage signals

Transducer/sensor	Rated value
Current transformer	1A or 5A
Voltage Transformer	100V
Rogowski coil	150 mV
Voltage sensor	2V

To test the phase sequence, set every phase separately to the rated value and then check the value on the LC display screen. At the end reset the phase to zero.

Generate one symmetrical system each for current and voltage with the rated values.

Check the calculated values. A three-phase current and voltage tester is recommended to test the power. By changing the phase angle between the current and the voltage system the calculation of reactive and effective values and of  $\cos \varphi$  can be checked.

## 5.7 Testing the protective functions

To ensure that no damage has been caused by transport or setup and installation of the protection equipment and systems, secondary tests are run on the REF542*plus* protection and control unit with the configured protective functions.

### **Warning!**

**Always observe the applicable safety regulations when conducting the secondary test with an appropriate test set.**

### **Caution**

**When testing ensure that the limit values of the measuring inputs and the auxiliary voltage supply are not exceeded.**

Secondary function tests are recommended during commissioning of the protective functions.

The activated and configured automatic auto reclosure and also other functions of the complete system and the power circuit-breaker should be tested to ensure safe operation of these functions.

The following points are particularly important for protective functions that must work in connection with a set direction or energy flow quantity.

Checking the sensor and transformer connections and wiring check of the station circuit diagram

Determining the transformer direction

Connection and documentation of the test set

Testing and documentation of the measured value recording

Setting parameters for the protective functions

Recording the test settings

To monitor the test of the correct direction of the specific protective functions in comparison with the measured power and power factors in the event of a later primary test, the following information should be documented in the secondary tests:

Directional setting of the test set

Measurement of the effective and reactive power and of the  $\cos \varphi$  factor

Directional setting of the measurement and protective functions

## 6 Troubleshooting

In this chapter you will find information on

Self test of the Central unit

Self test of the HMI

By means of the self test the proper function of the REF542*plus* can be checked. It is to be recommended that the self test is done in uninstal condition of the REF542*plus*. At least no connection to the primary system should be left. Beside that, the upgrade the firmware will also be described.

### 6.1 Safety Information

If there is any doubt regarding the treatment of a message, please check with our service representative.

### 6.2 Required devices and facilities

#### 6.2.1 Sinusoidal generator

The generator must have the following features in case of using the analog inputs of the REF542*plus* with current and voltage transformers:

- Accuracy class: 0.5
- Current output : 1 respective 5 A 50 Hz AC minimum
- Voltage output: 100 V 50 Hz AC minimum
- Voltage output: 2 VRMS 50 Hz AC

The generator must have the following features in case of using the analog inputs of the REF542*plus* with current and voltage sensors:

- Accuracy class: 0.5
- Current output : 150 mV 50 Hz AC minimum
- Voltage output: 2 VRMS 50 Hz AC minimum

#### 6.2.2 Adjustable power supply

with the following features:

- Voltage output: 30 – 240 V DC
- Power : 500 VA
- Accuracy class: 5, <12% ripple

#### 6.2.3 Personal computer

The PC (usually laptop) must be provided with at least one RS232 port for serial communication respectively data transfer. Two RS232 ports will give better operation condition. Thereby, the following software must be installed:

- REF542*plus* official released configuration software (example V4B01)
- Tera Term Pro software

#### 6.2.4 Tera Term Pro

Tera Term Pro is a freeware terminal program for communication between the PC and the hardware of the REF542*plus*, the Central Unit or the HMI Local Control Unit,

The setting for the communication with the Central Unit can be seen in the next figure, which can be stored e.g. using the file name MCTERM:INI: This setting file can be used later, if a communication with the Central Unit is necessary.



**Figure 20:** Setting of the communication to the Central Unit

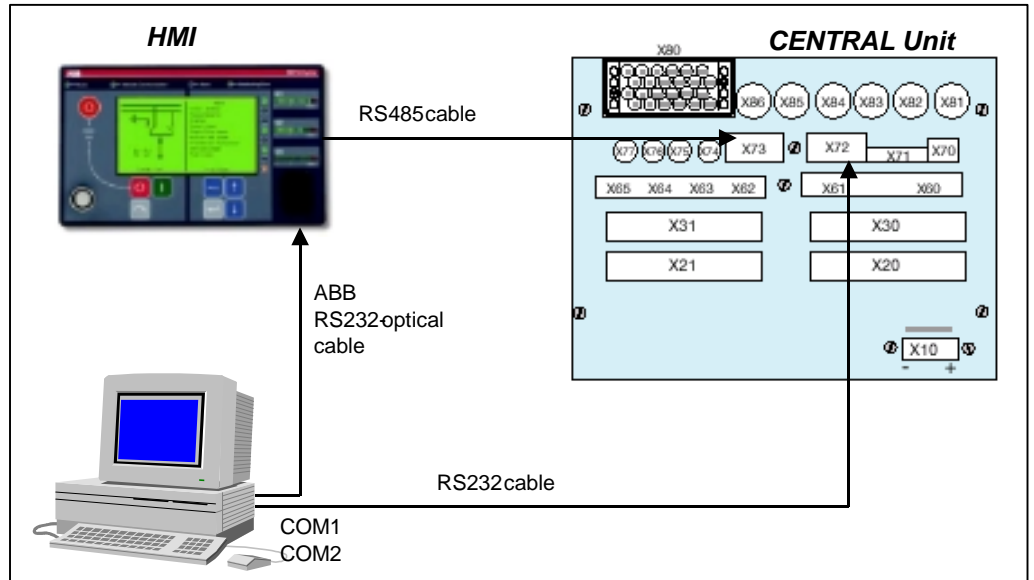

**Figure 21:** Setting of the communication to the HMI

The above figure shows the setting for the communication to the HMI Local Control Unit and can be stored e.g. as RHMITERM.INI.

### 6.2.5 Connection cables

The next figure show the set up for trouble shooting. There are several cables needed to link the PC and the REF542*plus*:



**Figure 9:** Test configuration of the REF542*plus*

### 6.2.5.1 RS232 cable

This standard serial communication cable is needed for the communication between the PC and the Central Unit. The connector on the central unit for this purpose is X72.

### 6.2.5.2 REF542*plus* optical cable.

The HMI must be interfaced to a PC through the ABB RS232 optical cable. The optical converter must be plugged in the connector situated on the front side of the HMI. By using this interface the configuration file can be downloaded or uploaded from the local PC, which hosts the configuration tool, to the REF542*plus* central unit. Besides that, protection and operation events and the value of the measurement quantities stored in the REF542*plus* can be uploaded from the local PC for monitoring purpose.

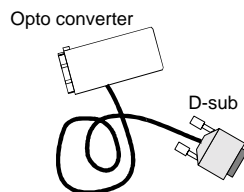

**Figure 22:** ABB RS232 - optical cable for the connection to the HMI

### 6.2.5.3 RS 485 Cable

This cable is normally used for the connection between the HMI as Local Control Unit and the Central Unit in the LV compartment. This cable is connected to the connector X73 on the Central Unit.

## 6.3 Self test of the Central Unit

By means of the self test the functionality of the REF542*plus* Central unit can be proved.

### 6.3.1 Behavior after cold start

To see the behavior after cold start the following condition is to be prepared:

- The PC must be connected via the serial interface RS232 to the connector X72.
- The Tera Term Pro software is running and configured with the setting file MCTERM.INI.
- The related power supply voltage must be connected to connector -X10.
- The HMI Local Control Unit must not be connected to the Central Unit.

After the central unit starts up, the software Tera Term Pro shows messages as displayed in the following figure.

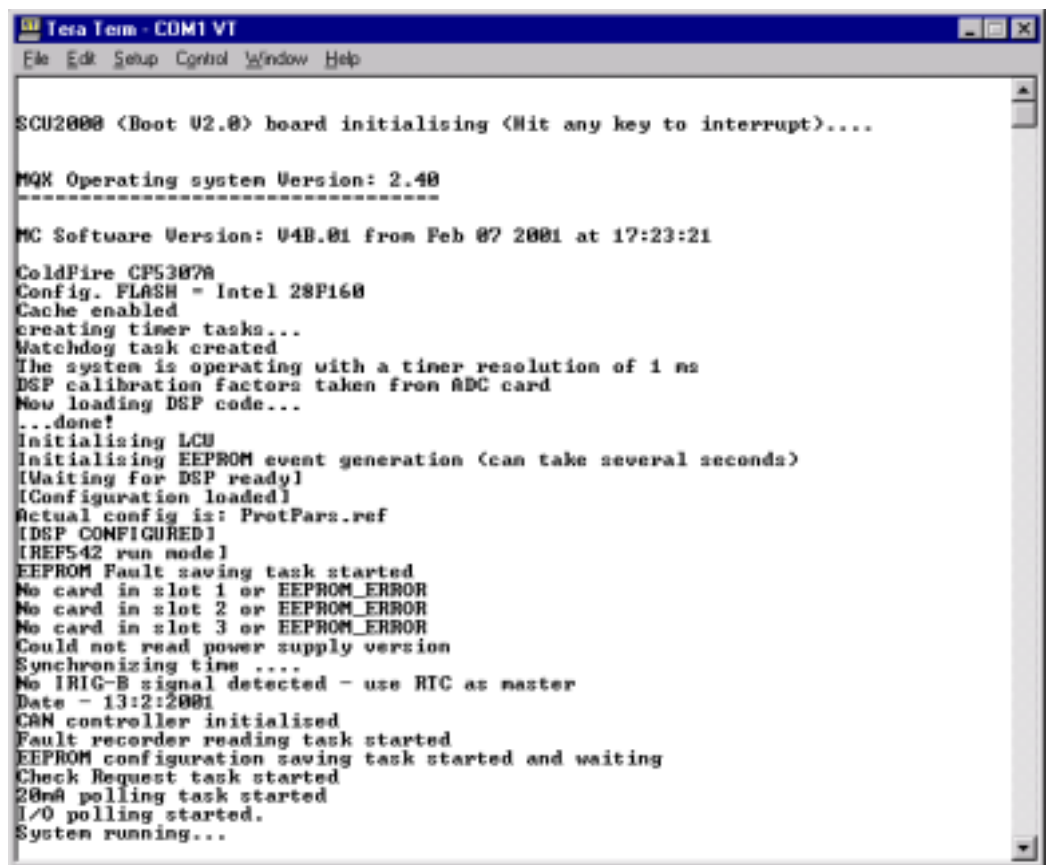

```

Tera Term - COM1 VT
File Edit Setup Control Window Help

SCU2000 <Boot V2.0> board initialising <Hit any key to interrupt>....

MQM Operating system Version: 2.40
-----
MC Software Version: V4B.01 from Feb 07 2001 at 17:23:21

ColdFire CP5307A
Config. FLASH = Intel 28P160
Cache enabled
creating timer tasks...
Watchdog task created
The system is operating with a timer resolution of 1 ms
DSP calibration factors taken from ADC card
Now loading DSP code...
...done!
Initializing LCU
Initializing EEPROM event generation (can take several seconds)
[Waiting for DSP ready]
[Configuration loaded]
Actual config is: ProtParas.ref
[DSP CONFIGURED]
[REF542 run mode]
EEPROM Fault saving task started
No card in slot 1 or EEPROM_ERROR
No card in slot 2 or EEPROM_ERROR
No card in slot 3 or EEPROM_ERROR
Could not read power supply version
Synchronizing time ....
No IRIG-B signal detected - use RTC as master
Date - 13:2:2001
CAN controller initialized
Fault recorder reading task started
EEPROM configuration saving task started and waiting
Check Request task started
20ms polling task started
I/O polling started.
System running...
  
```

**Figure 10:** Correct start up sequence of Central Unit displayed by Tera Term Pro software

The REF542*plus* is after the indication “system running” in operation again. If the HMI Local Control Unit is connected, then on the LCD screen the single line diagram and the menu will be displayed.

### 6.3.2 Enter REF542*plus* self test

If a self test should be performed, press a key on the PC keyboard within a couple of seconds after the Central Unit is powered on again. The TeraTerm Pro software will display the following messages on the PC:

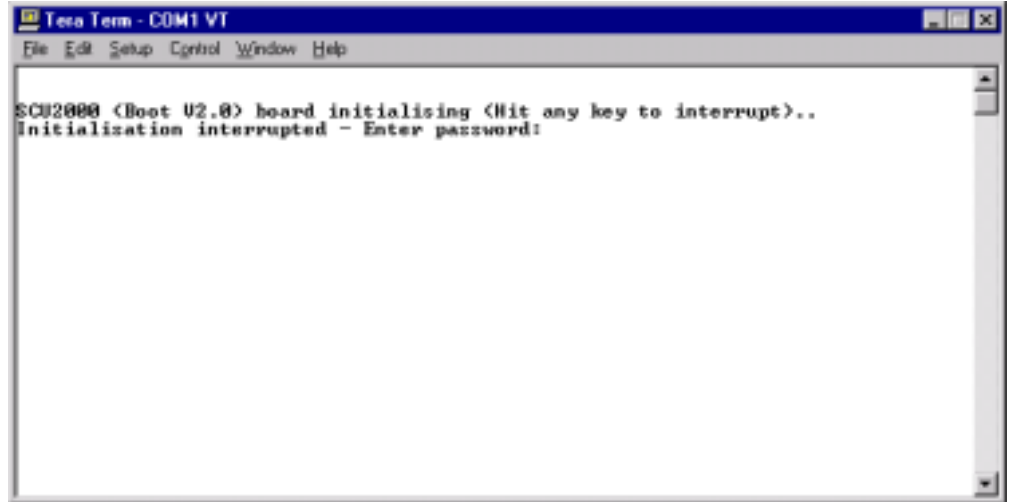

**Figure 23:** Tera Term Pro display for entering the self test of the Central Unit

Type the proper password and press 'enter'. Ask for the password from the authorized personnel in your local ABB representative. After typing the correct password, the following sub-menu will be shown:

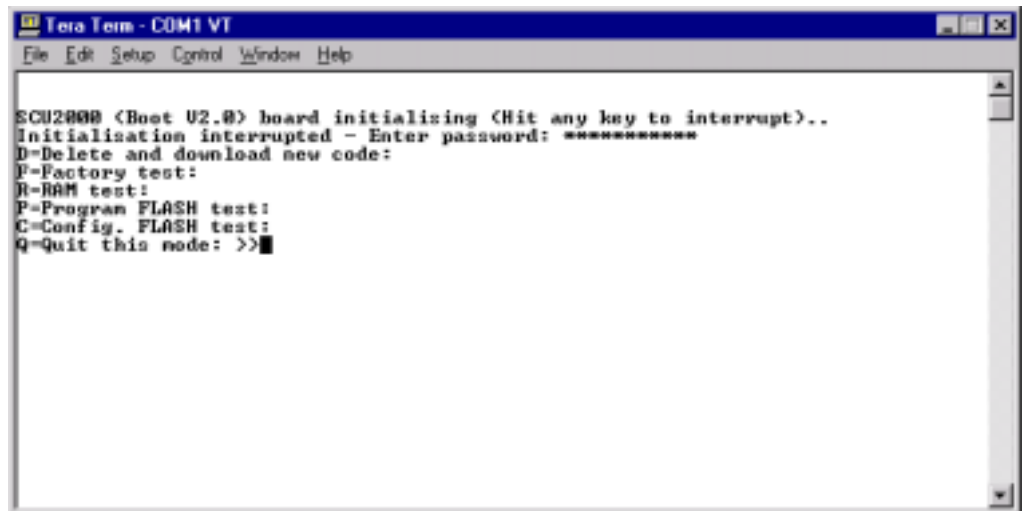

**Figure 24:** Display on Tera Term Pro Window after entering the right password

To verify the functionality the following test can be performed:

### 6.3.2.1 RAM test

Press “r”

2 Mbyte RAM is being tested

Test result is shown on the terminal

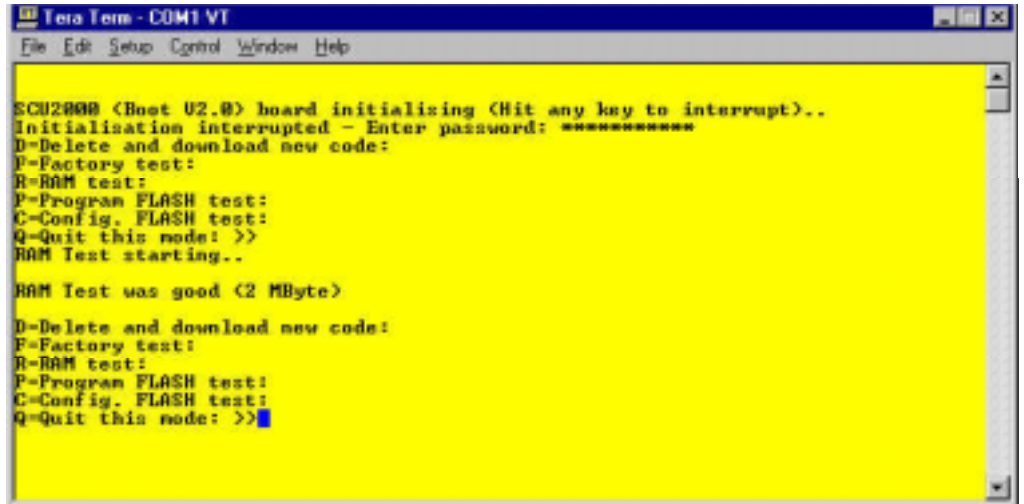

```

Tera Term - COM1 VT
File Edit Setup Control Window Help

ECU2808 (Boot U2.8) board initializing (Hit any key to interrupt)..
Initialization interrupted - Enter password: *****
D-Delete and download new code:
F-Factory test:
R-RAM test:
P-Program FLASH test:
C-Config. FLASH test:
Q-Quit this mode: >>
RAM Test starting..

RAM Test was good (2 MByte)

D-Delete and download new code:
F-Factory test:
R-RAM test:
P-Program FLASH test:
C-Config. FLASH test:
Q-Quit this mode: >>
  
```

Figure 11: Display of the result after RAM test

### 6.3.2.2 Program flash memory test

Press “p”

16 Mbit flash is being tested. This test will destroy the actual application firmware on the program flash. Application firmware must be downloaded afterwards by “d” command.

Test result is shown on the terminal.

### 6.3.2.3 Configuration flash memory test

Press “c”

16 Mbit flash is being tested. This test will destroy the actual configuration (if any) on the data flash.

Test result is shown on the terminal

## 6.3.3 Calibration of the Analog Input

The calibration of the REF542plus is normally not necessary, because the related calibration data are stored in the memory of the analog input board itself. But if e.g. one of the CT or VT on the analog input board is removed or substituted, a recalibration has to be done. For this reason the so called factory test mode must be entered by typing **£** after entering the self test mode. After some seconds, a menu with possible operations is shown on the PC terminal. The following commands are available:

**Table 12:** All available commands on the factory test mode

Command	Description
s	set time to RTC
a	set A/D calibration parameter
p	display A/D calibration parameter
w	test DSP watchdog
f	test fast I/O and DSP trip interrupt
g	GPS IRIG-B test
b	test binary I/O board
k	enter DSP calibration mode
r	read communication board version
u	show DSP RAM test result
h	show help (e.g. the present table)

As can be seen from the table the calibration mode can be entered by selecting the command k. In this mode the offset errors of the signal conditioning chain for the further processing of the analog input signals in the REF542*plus* unit can be compensated. Moreover the connections to the connector X80 can be defined. Afterwards the calibration data are stored on the EEPROM on the Analog Input Board.

- The calibration procedure needs the following preparation:
- Sinusoidal generator as already mentioned in chapter 6.2.1.
- Put in the jumper X12, which is located near to the back plane connector.

### 6.3.3.1 Transformer Input Board

The board must be supplied at X80 connector with:

- 1A, 50 Hz with accuracy class 0.5 at the 1A current inputs pins
- 0,2A, 50 Hz with accuracy class 0.5 at the 0,2A current inputs pins, normally on input channel 7 and/or 8
- 100 V RMS, 50 Hz. with accuracy class 0.5 at the voltage inputs

Note

During the calibration procedure all signals used calibration must be in phase!

### 6.3.3.2 Sensor Input Board

The board must be supplied at the X81...X88 connectors at the same time with signals of 2V, 50 Hz with an accuracy class 0.5

Note

During the calibration procedure all signals used calibration must be in phase!

### 6.3.3.3 Mixed Input Board

In this case the board must be supplied at

- X80 current inputs with 1A, 50 Hz with accuracy class 0.5
- X80 voltage inputs with 100V, 50 Hz. with accuracy class 0.5
- X81..X86 with 2 V, 50 Hz accuracy class 0.5

Note

During the calibration procedure all signals used calibration must be in phase!

### 6.3.3.4 Calibration procedure

Before starting the calibration procedure, the protection unit housing must be grounded. Beside that, the shielding screw on the analog input board must also be in.

**Caution** Before starting the calibration procedure, the jumper X12 must be put in

After switching on all the input signals for running the calibration procedure can be started. For each possible analog input channel (from 1 to 8) the following selection must be done:

- **c**, if the input is a current transformer (1A).
- **v**, if the input is a voltage transformer (100V).
- **s**, if the input is a sensor (2V)
- **x**, if you like to skip the calibration for the channel.

After entered 8<sup>th</sup> channel input settings the calibration procedure starts automatically the calculation of calibration factors and after some seconds, it ends. The report shows at the corresponding input lines the calibration result with channel accuracy. In case of wrong connections to the input a phase error will be reported. The following figure shows the returned messages of the calibration procedure in case of phase error.

```

Tera Term - COM1 VT
File Edit Setup Control Window Help

Calibration procedure

Please enter your analogue inputs board configuration

c = current transformer (supply the input with 1 A RMS, 50 Hz)
v = voltage transformer (supply the input with 100 V RMS, 50 Hz)
s = sensor (supply the input with 2 V RMS, 50 Hz)
x = not used

Channel #1 : voltage transformer
Channel #2 : voltage transformer
Channel #3 : voltage transformer
Channel #4 : current transformer
Channel #5 : current transformer
Channel #6 : current transformer
Channel #7 : current transformer
Channel #8 : not used

Calibrating analogue board...

Channel #1 calibrated: calib. factor = 0x4398f8 (185.57 % of default value)
Channel #2 calibrated: calib. factor = 0x446824 (186.84 % of default value)
Channel #3 calibrated: calib. factor = 0x447b89 (187 % of default value)
Channel #4 calibrated: calib. factor = 0x45838a (187.83 % of default value)
Channel #5 calibrated: calib. factor = 0x45838a (187.83 % of default value)
Channel #6 calibrated: calib. factor = 0x45aa37 (188.85 % of default value)
Channel #7 calibrated: calib. factor = 0x45febd (189.37 % of default value)

Measurement errors with new calibration factors:

Channel #1: Error is -0.14 % of nominal value
Channel #2: Error is 0 % of nominal value
Channel #3: Error is 0.02 % of nominal value
Channel #4: Error is -0.11 % of nominal value
Channel #5: Error is 0.1 % of nominal value
Channel #6: Error is -0.11 % of nominal value
Channel #7: Error is 0.1 % of nominal value

Phase error check:

Channel #1 connection: reference
Channel #2 connection: OK!
Channel #3 connection: OK!
Channel #4 connection: WRONG!
Channel #5 connection: OK!
Channel #6 connection: OK!
Channel #7 connection: OK!

Calibration finished...

```

Figure 25: Calibration of channel 4 with wrong connections phases to X80

At the end of the calibration procedure it must be verified that all the configured channels has been configured and the phase error check reports no errors.

**Caution** At the end of the calibration phases the Jumper X12 must be removed.

## 6.4 Remote HMI self test

The following test procedure is applicable since the implementation of the software version 4B 01. To carry out the test the following steps must be done:

Connect the power supply to the connector X10. Take care of the voltage level of the HMI.

Switch on the power supply of the HMI Local Control Unit.

The connection to the Central Unit shall be removed.

When the RHMI is not connected to the protection unit shows the following screen:

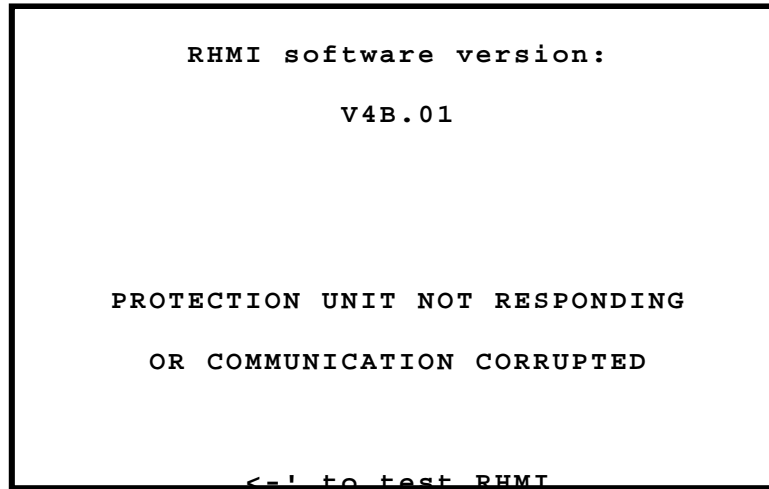

**Figure 26:** Display on the LCD screen after switching on the power supply

By pressing the return key a “Stand alone” mode on the LCD display is shown. The test can be run individually or all together in sequence by selecting the corresponding menu line. In this case the e-key with the ABB code must be inserted in its plug and loop back cable must be inserted in X20 and in the optical interface in advance.

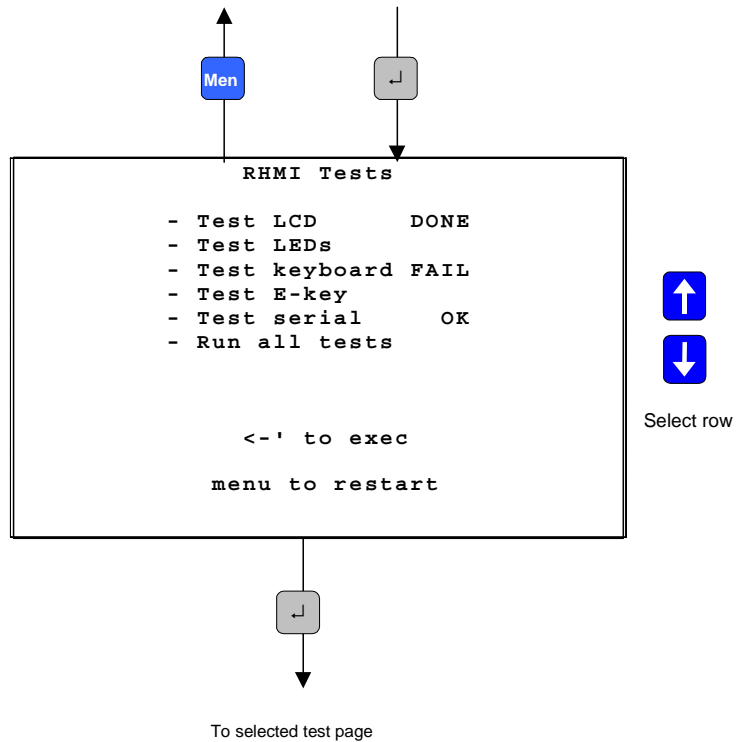

**Figure 12:** “Stand alone” Test Page

At the end of each test display line a place is left for the test result. The test result can be:

**DONE** (for LCD and LEDs tests)

**FAIL** or **OK** (for Keyboard, E-Key and Serials tests)

Each time the HMI Test Page (each of the two type) is accessed the place for the result is set to blank. After a test is run the corresponding result is shown. If the menu option "Run all tests" is selected, all tests results will be displayed.

The following paragraphs describe the performing of single test.

### 6.4.1 LCD test

This test consists in the following four parts. Each part has a corresponding page and there is a 2 seconds delay between one test and the following one.

A manual verification by the test operator is needed to check the test result.

#### 6.4.1.1 Texts writing test

LCD page is displayed

1 second delay

The LCD page is cleared

The test is carried out. It writes the text as shown in the next figure

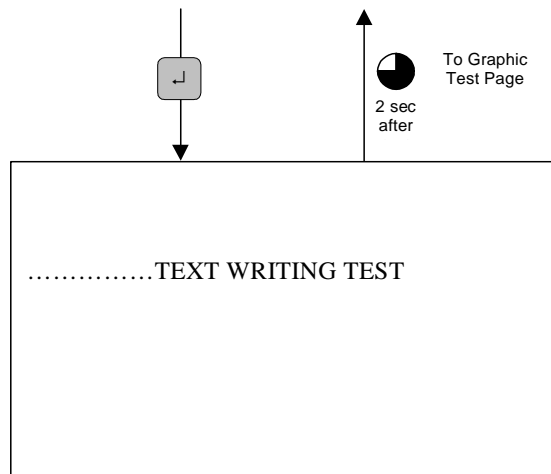

**Figure 27:** LCD Display during Text Writing test

2 seconds delay. After the delay time is expired the following next test will be started automatically:

#### 6.4.1.2 Graphic writing test

The LCD page is displayed

1 second delay

The LCD page is cleared

Test carried out. It writes the text as shown in the next figure

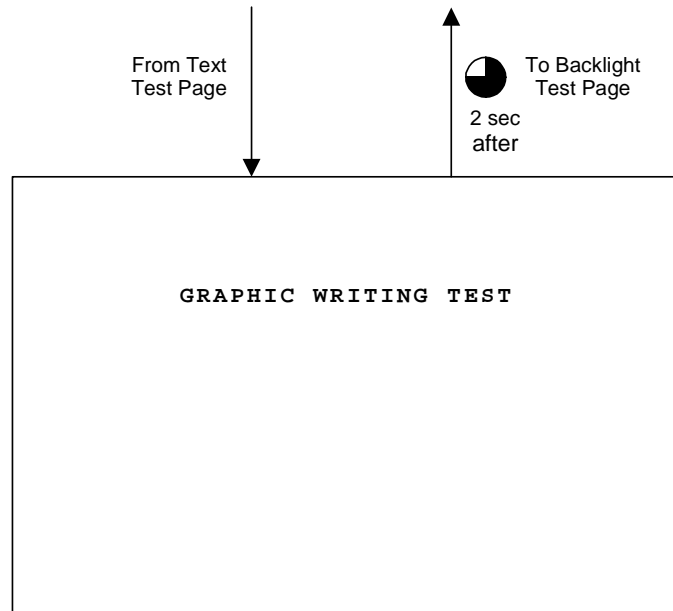
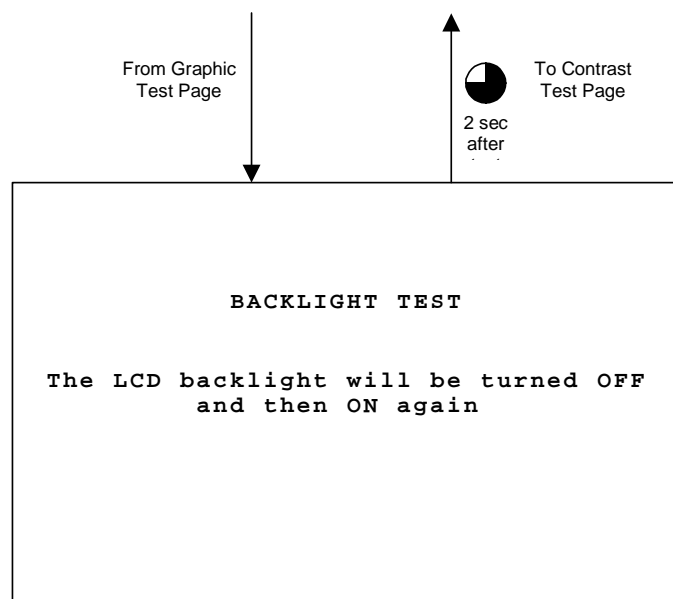

**Figure 28:** LCD display during Graphic Writing test.

2 seconds delay. After the delay time is expired the following next test will be started automatically:

#### 6.4.1.3 Back-light test

The LCD Page is displayed



**Figure 13:** Back-light Test Page

2 seconds delay

Back light off

1 second delay

Back light on

2 seconds delay. After the delay time is expired the following next test will be started automatically:

**6.4.1.4 LCD contrast test**

The following LCD page is shown

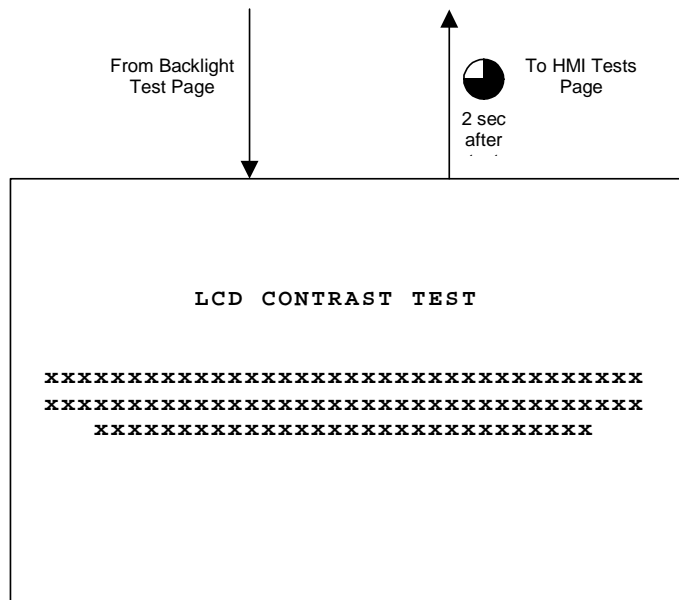

**Figure 14:** LCD Contrast Test Page

2 seconds delay

Contrast varied from minimum to maximum (in a total time of 2 seconds) and then restored to previous value

2 seconds delay. After the delay time is expired the HMI Test menu will be displayed automatically:

### 6.4.2 LEDs test

This test consists of the following steps:

The LCD page for for the LED Test is displayed

1 second delay

Then the test carried out, in which the LED's will be switched on and the colors will be cyclic changed

After finishing the test, the HMI test page will be displayed again automatically.

### 6.4.3 Keyboard test

This test consists of the following steps:

The keyboard test page is displayed on the LCD

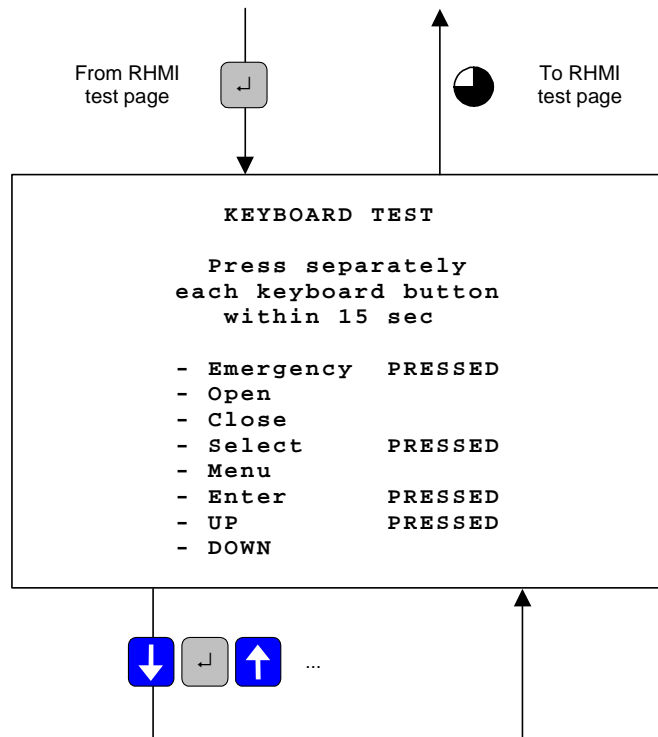

**Figure 15:** Keyboard Test Page

Each keyboard buttons has to be pressed one by one, no matter the order. When a button is pressed the “PRESSED” string is displayed in the corresponding page line.

When all buttons have been pressed, after 1-second delay, the test ends with OK result.

If after 15 seconds not all buttons have been pressed, the test ends with FAIL result.

After finishing the test, the HMI test page will be displayed again automatically.

### 6.4.4 E-Key test

This test consists of the following steps:

The LCD display for the E-Key Test Page is shown in the following figure:

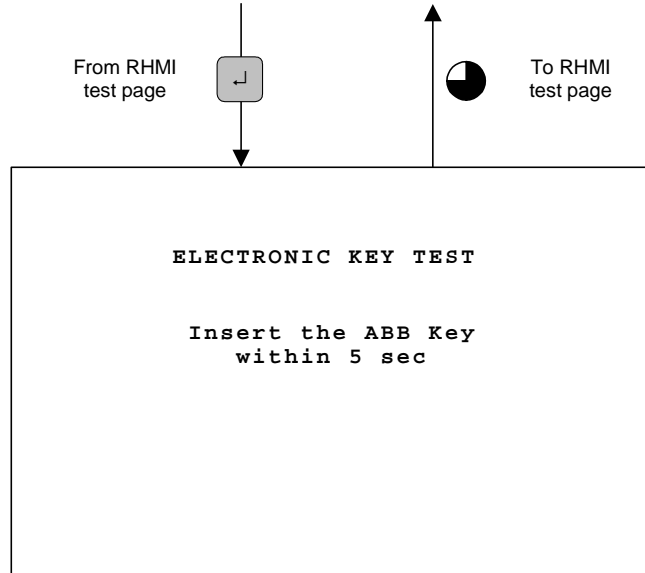

Figure 16: E-Key Test Page

The so called ABB-key must be inserted within 5 seconds. Afterwards the test will end with OK result. Otherwise, the result is FAIL.

### 6.4.5 Serial ports test

This test is performed by connecting the loop-back cable, cable that is normally used for the connection between PC and HMI Local Control Unit, between the port X20 and the optical connector on the HMI front panel.

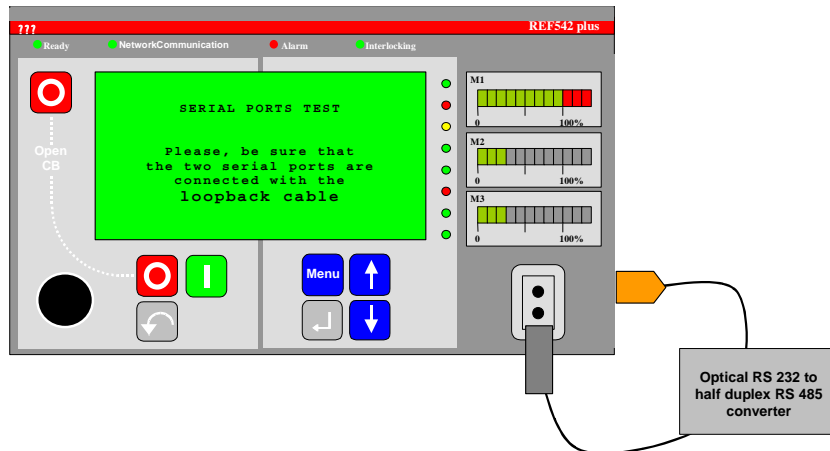
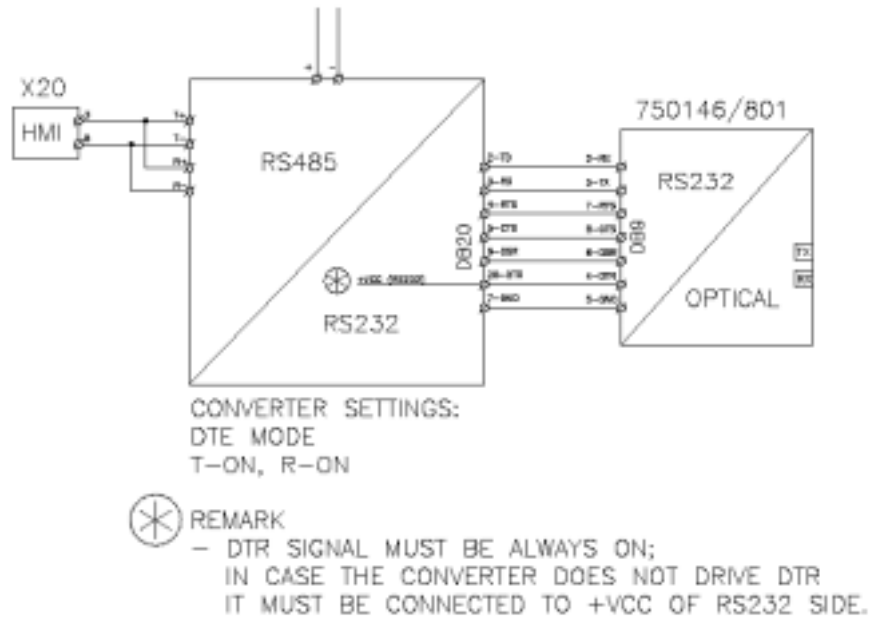

Figure 17: RHM serial ports test



**Figure 18:** Loop-back cable for the RHMI serial ports test

The test will consist in the following steps:

The LCD page for the serial ports test is displayed according to next figure:

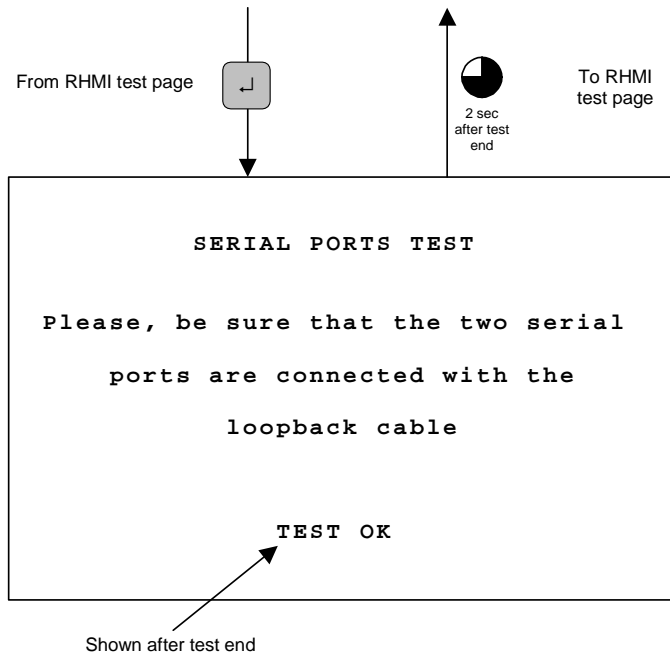

**Figure 19:** Serial Ports Test Page

RS485 to RS232 communication test

10 telegrams will be sent to the optical port.

RS232 to RS485 communication test

10 messages are sent to the RS 485 port.

Test result shown in the page (“TEST OK” or “TEST FAIL”)

2 seconds delay.

After finishing the test, the HMI test page will be displayed again automatically.

## 7 Firmware upgrade

In the following the upgrade of the firmware is described. The possibility of upgrading the firmware is to be asked to the authorized personnel to your local ABB representative.

### 7.1 Upgrade the Firmware of the Central Unit

Use the RS232 port X72 on the Central Unit of the REF542*plus*.

Connect to the serial RS232 port on the PC with the TeraTerm Pro software with the set up file MCTERM.INI.

Turn on the power supply for the Central Unit and press a key on the PC keyboard within a couple of seconds

Type the proper password and press 'enter'

Type "d" and at prompt answer yes by pressing "y"

From the menu File in Tera Term Pro select "send file"

Select the new main-board firmware to download and click "Open"

After the download is completed, the Central Unit should reset itself and run the new firmware.

### 7.2 RHMI firmware upgrade

Set Tera Term Pro software with the set up file RHMITERM.INI.

Connect the RHMI to a PC through the optical cable

Turn ON the power supply for the HMI Local Control Unit and press "enter button" on the PC within a couple of seconds (if not, the RHMI application starts normally)

Select the "Send File..." item on TeraTerm "File" menu

Choose the firmware file. "Binary" option should be DISABLED

Wait until the file has been uploaded to HMI (one or two minutes)

At the end of the upload, the newly uploaded firmware version starts

---

**Note**

Only HMI with software version 4B01 can be uploaded with this boot loader

## 8 Decommissioning and Storage

In this chapter you will find information

On decommissioning the unit

Storing the REF542*plus* after decommissioning or before commissioning.

### 8.1 Decommissioning

Please observe the following directions when decommissioning the unit:

Isolate the bay

Transfer the configuration from the REF542*plus* to the PC and save it on data media

Switch off the REF542*plus* auxiliary supply voltage

Switch off the remaining miniature circuit breakers as well

If applicable, isolate all current transformers

Disconnect the REF542*plus* from the measuring circuits

Remove all plug connectors

Remove the unit

Check the unit for damage.

Pack the REF542*plus* properly; preferably in the original packaging

Store the unit on its side beforehand as specified.

It is not necessary to decommission the configuration program. If you wish to uninstall the configuration program, follow the relevant directions.

### 8.2 Storage

Please observe the following minimum requirements for optimum storage:

Units with standard packaging or without packaging

Dry and well ventilated storage space, conditions in accordance with DIN VDE 0670 Part 1000/IEC 60694,

If packaging is used, it must be undamaged or

units without packaging must be well covered with protective sheets; however, ensure sufficient air circulation to prevent corrosion.

Check the unit regularly for condensation.

## 9 Technical data

### 9.1 Analog input channels

Accuracy for measurement including the current/voltage sensors class 1.  
Accuracy for protection class 3

#### 9.1.1 With current and voltage transformer:

Rated current $I_n$	1A or 5A
Rated voltage $U_n$ :	100V (also suitable for 110V)
Rated frequency $f_n$ :	50 Hz / 60 Hz

<b>Thermal load capacity</b>	
Current path	250 $I_n$ (peak value) dynamic, 100 $I_n$ for 1s, 4 $I_n$ continuous,
Voltage path	2 $U_n / \sqrt{3}$ continuous.
<b>Consumption</b>	
Current path	$\leq 0.1$ VA with $I_n$
Voltage path	$\leq 0.25$ VA with $U_n$

#### 9.1.2 With current and voltage sensor

Rated current $I_n$	150 mV (rms)
Rated voltage $U_n$ :	2V (rms)
Rated frequency $f_n$ :	50 Hz / 60 Hz

## 9.2 Binary inputs and outputs

Each binary I/O board has the following number of inputs and outputs:

### 9.2.1 With mechanical relays (1 BIO version 3)

14 inputs (BI 1 to 14)	For auxiliary voltage range: 20 to 90 V DC (threshold 14 V DC) or for auxiliary voltage range: 80 to 250 V DC (threshold 50 V DC)  Each input has a fixed filter time of 1 ms. Extension can be freely programmed.
5 power outputs (BO 1,2,3,4 and 5) respectively 6 (Relay contact of BO6 is link together with re- lay contact of BO5)	Maximal Operation voltage 250V AC/DC Make current 20 A Load current 12 A Breaking capacity 300 W at L/R = 15 ms Operation time 9 ms
2 signal outputs (BO7 and 8) and 1 Watchdog output (WD)	Operation voltage 250 V AC/DC Load current 2 A Operation time 5 ms
1 Static output (optionally BO7)	Maximal Operation voltage 250 VDC Operation time 1 ms
1 coil supervision circuit (BO2)	

### 9.2.2 With static outputs (1 BIO version static)

14 inputs (BI 1-14)	for auxiliary voltage range 48 to 265 VDC (Threshold 35 VDC)  Each input has a fixed filter time of 1 ms. Extension can be freely programmed.
3 power outputs (BO1,2 and 7)	Operation voltage 48 to 265 VDC Make current 70 A for $t \leq 10$ ms Load current 12 A for $t \leq 30$ s Operation time 1 ms
4 power outputs (BO3 to 6)	Operation voltage 48 to 265 V DC Make current 16 A for $t \leq 10$ ms Load current 10 A for $t \leq 30$ s Operation time 1 ms
2 Signal outputs and 1 Watchdog output	Operation voltage 48 to 265 V DC Make current 0.3 A Operation time 1 ms
2 coil supervision circuit (BO1 and 2)	

## 9.3 Interface

### 9.3.1 HMI Control Unit:

Optical/electrical standard interface RS 232 to the Notebook PC (at the front)

Electrical isolated standard interface RS 485 to the Central Unit (at the rear)

### 9.3.2 Central Unit:

Electrical isolated standard interface RS 485 to the HMI

Electrical standard interface RS 232 for updating the firmware

## 9.4 Analog output board (optional)

Four channel 0 to 20 mA respectively 4 to 20 mA

## 9.5 Communication (optional)

SPABUS, electrical interface with standard RS232 or optical interface with snap-in type connector for plastic fiber respectively standard FMA connector for glass fiber (multi mode)

LON (according to LAG1.4), optical interface with standard ST connector for glass fiber (multi mode)

IEC 60870-5-103 with extension according to VDEW guidelines for controlling, optical interface with standard ST connector for glass fiber (multi mode)

MODBUS RTU, electrical interface with two standard RS485 or optical interface with two standard ST connector for glass fiber (multi mode)

## 9.6 Power supply

### 9.6.1 Central Unit

Rated voltage	110 VDC (-15%, +10%), 220 VDC (-15%, +10%) or 48 to 220 VDC (-15%, +10%)
Power consumption	≤ 18 W (base version with 1 BIO)
Inrush current	≤ 10 A peak value

### 9.6.2 RHMI Control Unit

Rated voltage:	For auxiliary voltage in the range of: 48 ... 110 VDC (-15%, +10%) or 110 ... 220 VDC (-15%, +10%)
Power consumption	≤ 6 W

## 9.7 Temperature range

Operation	-5 ..+ 55°C
Transport and storing	-20..+70°C

## 9.8 Degree of protection

### 9.8.1 Central Unit

Housing	IP20
---------	------

### 9.8.2 RHMI Control Unit

Front	IP 54
Rear	IP 22

## 10 Type Test

### 10.1 Protection Function

All relevant tests according to the standard IEC 60255.

ANSI Code	Protection Function and the Setting Parameters	Test Procedure
68	Inrush stabilization (Only in connection with I>> and I>) N = 2.0 ... 8.0 M = 3.0 ... 4.0 Time = 220 ... 100.000 ms	IEC 60255-3
67	Overcurrent directional high I>> = 0,05 ... 40 In t = 70 ... 300.000 ms	IEC 60255-12
67	Overcurrent directional low I > = 0,05 ... 40 In t = 220 ... 300.000 ms	IEC 60255-12
50	Overcurrent instantaneous I>>> = 0,10 ... 40 In t = 15 ... 300.000 ms	IEC 60255-3
51	Overcurrent high I>> = 0,05 ... 40 In t = 40 ... 300.000 ms	IEC 60255-3
51	Overcurrent low I > = 0,05 ... 40 In t = 40 ... 300.000 ms	IEC 60255-3
51	IDMT Normal-, Very-, Extremely- or Longtime- inverse time characteristic I <sub>e</sub> = 0,05 ... 40 In K = 0,05 ... 1,5	IEC 60255-3
51N	Earth fault high IE>> = 0,05 ... 40 In t = 70 ... 100.000 ms	IEC 60255-3
51N	Earth fault low IE> = 0,05 ... 40 In t = 70 ... 100.000 ms	IEC 60255-3
67N	Earth fault directional high IE>> = 0,05 ... 40 In t = 40 ... 100.000 ms forward- / backward direction isolated (sin φ) and earthed (cos φ)	IEC 60255-12
67N	Earth fault directional low IE> = 0,05 ... 40 In t = 40 ... 300.000 ms forward- / backward direction isolated (sin φ) and earthed (cos φ)	IEC 60255-12

ANSI Code	Protection Function and the Setting Parameters	Test Procedure
67N	Earth fault directional sensitive $IE > = 0,05 \dots 2 I_n$ $t = 120 \dots 100.000 \text{ ms}$ , for- / backward Slope angle $\alpha = 0 \dots 20^\circ$ , Slope angle $\delta = -180 \dots 180^\circ$ $UNE > = 0,05 \dots 0,7 U_n$	IEC 60255-12
51N	Earth fault IDMT Standard, very, extremely or long time inverse time characteristic, $I_e = 0,05 \dots 40 I_n$ $k = 0,05 \dots 1,5$	IEC 60255-3
59	Overvoltage instantaneous $U_{>>>} = 0,10 \dots 3 U_n$ $t = 20 \dots 300.000 \text{ ms}$	IEC 60255-3
59	Overvoltage high $U_{>>} = 0,10 \dots 3 U_n$ $t = 70 \dots 300.000 \text{ ms}$	IEC 60255-3
59	Overvoltage low $U_{>} = 0,10 \dots 3 U_n$ $t = 70 \dots 300.000 \text{ ms}$	IEC 60255-3
27	Undervoltage instantaneous $U_{<<<} = 0,10 \dots 1,2 U_n$ $t = 50 \dots 300.000 \text{ ms}$	IEC 60255-3
27	Undervoltage high $U_{<<} = 0,1 \dots 1,2 U_n$ $t = 70 \dots 300.000 \text{ ms}$	IEC 60255-3
27	Undervoltage low $U_{<} = 0,1 \dots 1,2 U_n$ $t = 70 \dots 300.000 \text{ ms}$	IEC 60255-3
59N	Residual overvoltage high $UNE_{>>} = 0,05 \dots 3 U_n$ $t = 40 \dots 300.000 \text{ ms}$	IEC 60255-3
59N	Residual overvoltage low $UNE_{>} = 0,05 \dots 3 U_n$ $t = 40 \dots 300.000 \text{ ms}$	IEC 60255-3
49	Thermal overload protection (thermal equation 1 <sup>st</sup> order with complete memory function) $T_n = 50 \dots 400 \text{ }^\circ\text{C}$ (nominal temperature at $I_n$ ) $I_n (\text{Mot}) = 1 \dots 10000 \text{ A}$ (primary value of the nominal motorcurrent) $T_{ini} = 50 \dots 120 \% T_n$ (initial temperature at power on) $\tau_{cool} = 10 \dots 20.000 \text{ s}$ (time constant at $I < 0.1 I_n$ and $n = 0$ ) $\tau_{warm} = 10 \dots 20.000 \text{ s}$ (time constant normal) $\tau_{warm} = 10 \dots 20.000 \text{ s}$ (time constant at $I > 2 I_n$ ) $T_{max} = 20 \dots 400 \text{ }^\circ\text{C}$ (maximal temperature) $T_{warn} = 20 \dots 400 \text{ }^\circ\text{C}$ (warn temperature) $T_{envi} = 50 \dots T_{ini}$ (environment temperature)	IEC 60255-8

ANSI Code	Protection Function and the Setting Parameters	Test Procedure
51	<p>Motor start protection (adiabatic characteristic)</p> <p><math>I_e = 0,3 \dots 1,2 I_n</math> (motor current)  <math>I_s = 1,00 \dots 20 I_e</math> (start value)  <math>t = 70 \dots 300.000</math> ms  <math>I_{&gt;} = 0,6 \dots 0,8 I_s</math> (motor start)</p>	IEC 60255-3
51LR	<p>Blocking rotor (definite time characteristic)</p> <p><math>I_e = 0,3 \dots 1,2 I_n</math> (motor current)  <math>I_s = 1,00 \dots 20 I_e</math> (start value)  <math>t = 70 \dots 300.000</math> ms</p>	IEC 60255-3
66	<p>Number of starts</p> <p><math>n(\text{warm}) = 1 \dots 10</math> (number of warm starts)  <math>n(\text{cold}) = 1 \dots 10</math> (number of cold starts)  <math>t = 1.02 \dots 7200</math> s  <math>T(\text{warm}) = 20 \dots 200</math> °C (temperature limit warm start)</p>	
21+79	<p>Distance protection with autoreclosing</p> <p>System earthing = high/low ohmic  ct – grounding = line side, bus bar side  with/without earth start  switching onto faults = normal, overreach zone, trip after start  Signal comparison overreach scheme time set = 30 .... 300.000 ms</p> <p>U / I- Start characteristic:  <math>I_{&gt;}, I_{E&gt;} \text{ and } I_{F&gt;} = 0,05 \dots 4 I_n</math>  <math>U_{F&lt;} = 0,05 \dots 0,9 U_n</math>  Phase selection = cyclic/acyclic  Earth factor:  <math>k = 0,00 \dots 10,00</math>  <math>\varphi(k) = -60 \dots 60^\circ</math>  3 Impedance- and 1 overreachstage:  <math>R = 0,05 \dots 120 \Omega</math> (secondary values)  <math>X = 0,05 \dots 120 \Omega</math> (secondary values)  <math>t = 20 \dots 10.000</math> ms  1 directional stage  Direction 0 ... 90 bzw. -45 ... 135°  <math>t = 25 \dots 10.000</math> ms  1 non directional stage  <math>t = 25 \dots 10.000</math> ms  2 shots AR with short/long time reclosing</p>	IEC 60255-16
87	<p>Differential protection</p> <p>Transformer group = 0 ... 11  Transformer earthing = primary and or secondary side  Nom. current <math>I_n</math> on the primary/secondary side of the transformer = 0.00 ... 100.000A (prim value)  Threshold current = 0,10 ... 0,50 <math>I_n</math>  Unbiased region limit = 0.50 ... 5 <math>I_n</math>  Slightly biased region threshold = 0,20 ... 2 <math>I_n</math>  Slightly biased region limit = 1,00 ... 10,0 <math>I_n</math>  Slope = 0,40 ... 1,00  Trip with <math>I_{d&gt;} = 5,00 \dots 40 I_n</math>  Blocking by 2<sup>nd</sup> harmonic = 0.10 ... 0.30 <math>I_n</math>  Blocking by 5<sup>th</sup> harmonic = 0.10 ... 0.30 <math>I_n</math></p>	IEC 60255-13

ANSI Code	Protection Function and the Setting Parameters	Test Procedure
46	Unbalance load $I_s = 0,05 \dots 0,3 I_n$ (start value of the negative phase sequence) $K = 2 \dots 30$ $t_{Reset} = 0 \dots 200$ s Timer decreasing rate = 0 ... 100%	IEC 60255-3
32	Directional power Nominal real power $P_n = 1 \dots 1000.000$ kW (primary values) Max.reverse load $P > = 1 \dots 50$ % $P_n$ $t = 1,02 \dots 1000$ s	IEC 60255-12
37	Low load Nominal real power $P_n = 50 \dots 1000.000$ kW (primary values) Minimal load $P < = 5 \dots 100$ % $P_n$ Minimal current $I < = 2 \dots 20$ % $I_n$ $t = 1 \dots 1000$ s	IEC 60255-12
81	Frequency monitoring Start at $\Delta f = 0,04 \dots 5$ Hz $t = 1,02 \dots 300$ s	IEC 60255-3
25	Synchronism check $\Delta U = 0,02 \dots 0,4 U_n$ $t = 0,52 \dots 1000$ s $\Delta \varphi = 5 \dots 50^\circ$	IEC 60255-12
	Fault recorder Recording time = 1000 ... 5000 ms Pre fault time: = 100 ... 2000 ms Post fault setting = 100 ... 4900 ms Max. 5 records	IEC 60255-24
55	Power factor controller Power factor = 0,70 ... 1,00 $QC0 = 1,000 \dots 20000,000$ kVAr Series of banks = 1:1:1:1 ... 1:2:4:8 Number of banks : 1 ... 4 Insensitivity = 105 ... 200 % QC0 Threshold = 0 ... 100 % QC0 Switching program = sequential/circuit switching	IEC 60255-12

## 10.2 Electro Magnetic Compatibility

All relevant tests according to the standard IEC 60255, EN 61000 respectively to the new product standard EN 50263

### 10.2.1 Emission test

Port	Frequency range	Limits	Basic standard	Test procedure	Remarks
Enclosure	30 - 230 MHz	40 dB( $\mu$ V/m) quasi peak, measured at 10 m distance	EN 55022	EN 55022 See note 1	See note 2
	230 - 1000 MHz	47 dB( $\mu$ V/m) quasi peak, measured at 10 m distance			
Power Supply	0.15 - 0,50 MHz	79 dB( $\mu$ V) quasi peak, 66 dB( $\mu$ V) average	EN 55022	EN 55022 See note 1	
	0.5 - 5 MHz	73 dB( $\mu$ V) quasi peak, 60 dB( $\mu$ V) average			
	5 MHz - 30 MHz	73 dB( $\mu$ V) quasi peak, 60 dB( $\mu$ V) average			

NOTE 1 The test procedure given in EN 55022 will be superseded by that given in EN 60255-25 when it is published.

NOTE 2 May be measured at other distances. When this is done the test report should record the distance and the circumstances of the measurement. For test site measurements, an inverse proportionality factor of 20 dB per decade should be used to normalise the measured data to the specified distance for determining compliance.

### 10.2.2 Immunity tests - enclosure port

Environmental phenomena	Test specification	Units	Basic standard	Test procedure	Acceptance criteria	Remarks
Radiated radio frequency electromagnetic field, Amplitude modulated	80 – 1000 10  80	MHz V/m (unmod, rms) % AM (1 kHz)	EN 61000-4-3	EN 61000-4-3 See note 1	See 15.2 and note 1	See note 2
Radiated electromagnetic field from digital radio telephones, Pulse modulated	900 ± 5, additional 1890 ± 5 10 50 200	MHz MHz V/m (unmod., rms) Duty cycle % Rep. Frequency Hz	EN 61000-4-3	EN 61000-4-3 See note 1	See 15.2 and note 1	
Electrostatic discharge	6 (Cont. discharge)	kV (charge voltage)	EN 61000-4-2	EN 60255-22-2	EN 60255-22-2	See EN 60255-22-2, applicability of contact and air discharge test.
	8 (Air discharge)	kV (charge voltage)				
Power frequency magnetic field	50 30	Hz A(rms)/m (continuous)	EN 61000-4-8	EN 61000-4-8	See 15.2	See note 3
	300	A(rms)/m (1 to 3 sec)				
	additional 500 continuous	A(rms)/m				
<p>NOTE 1 The test procedure given in EN 61000-4-3 and the acceptance criteria given in 7.2 will be superseded by that given in EN 60255-22-3 when it is published.</p> <p>NOTE 2 Except for the ITU broadcast frequency bands: 87 MHz - 108 MHz, 174 MHz - 230 MHz, and 470 MHz – 790 MHz where the level is 3 V.</p> <p>NOTE 3 Applicable only to apparatus containing devices susceptible to magnetic fields, e.g. Hall elements, magnetic field sensors, etc.</p>						

### 10.2.3 Immunity tests - power supply port

Environmental phenomena	Test specification	Units	Basic standard	Test procedure	Acceptance criteria	Remarks
Conducted disturbance induced by radio-frequency fields, amplitude modulated	0,15 – 80 10	MHz V (unmod., rms)	EN 61000-4-6	EN 61000-4-6 See note 1	See 15.2 and note 1	See note 2
	80 150	% AM (1 kHz) ohms Source impedance				
Fast transients	5/50 5  2 2/2.5	Tr/Th ns kHz repetition frequency kV (peak) kV/kHz	EN 61000-4-4	IEC 60255-22-4	IEC 60255-22-4	
1 MHz burst  Differential mode Common mode	1 75 400  200  1 2,5	MHz frequency Tr ns Hz repetition frequency ohms Source impedance kV (peak) kV (peak)	IEC 60255-22-1	IEC 60255-22-1	IEC 60255-22-1	
Surge Differential mode  Common mode source	1,2/50 (8/20) 1  2  12	Tr/Th ms kV charge voltage  kV charge voltage  ohms Source impedance	EN 61000-4-5	EN 61000-4-5	See 15.2	See note 3
Voltage Interruption	100  5, 10, 20, 50, 100 and 200	% reduction  ms interruption time	IEC 60255-11	IEC 60255-11	IEC 60255-11	See note 4
Damped oscillatory wave Differential mode Common mode  Insulation	0.1/1/10/50  1 2.5  2 or 3 5	MHz  kV kV  kV/AC 1 Minute kV/DC 1 Minute kV impulse 1,2/50us; 0.5J	IEC 61000-4-12    IEC60255-5	IEC 61000-4-12    IEC60255-5	See 15.2    IEC60255-5	See note 4

NOTE 1 The test procedure given in EN 61000-4-6 and the acceptance criteria given in 7.2 will be superseded by that given in EN 60255-22-6 when it is published.

NOTE 2 Except for the ITU broadcast frequency band: 47 MHz - 68 MHz where the level is 3 V.

NOTE 3 Applicable only to ports interfacing with cables, the total length of which according to the manufacturer's functional specification may exceed 10 m.

NOTE 4 10 and 50 MHz is for GIS applications relevant

NOTE 5 The guaranteed interruption time must be mentioned in the data sheet (REF542plus 50ms)

### 10.2.4 Immunity tests - communication ports

Environmental phenomena	Test specification	Units	Basic standard	Test procedure	Acceptance criteria	Remarks
Conducted disturbance induced by radio-frequency fields, amplitude modulated	0,15 – 80 10 80 150	MHz V (unmod., rms) % AM (1 kHz) ohms Source impedance	EN 61000-4-6	EN 61000-4-6 See note 1	See 15.2 and note 1	See note 2 & 3
Fast transients	5/50 5 12	Tr/Th ns kHz repetition frequency kV (peak)	EN 61000-4-4	IEC 60255-22-4	IEC 60255-22-4	See note 3
1 MHz burst	1 75 400 200	MHz frequency Tr ns Hz repetition frequency ohms Source impedance	IEC 60255-22-1	IEC 60255-22-1	IEC 60255-22-1	See note 3
Differential mode Common mode	0 1	kV (peak) kV (peak)				
Insulation	0.5 additional 2	kV/DC 1Minute kV/AC 1 Minute	IEC60255-5	IEC60255-5	IEC60255-5	
Damped oscillatory wave Differential mode Common mode	0.1/1/10/ 50 0.5 1	MHz kV kV	IEC 61000-4-12	IEC 61000-4-12	See 15.2	See note 4

NOTE 1 The test procedure given in EN 61000-4-6 and the acceptance criteria given in 7.2 will be superseded by that given in EN 60255-22-6 when it is published.  
NOTE 2 Except for the ITU broadcast frequency band: 47 MHz - 68 MHz where the level is 3 V.  
NOTE 3 Applicable only to ports interfacing with cables, the total length of which according to the manufacturer's functional specification may exceed 3 m.  
NOTE 4 10 and 50 MHz is for GIS applications relevant

### 10.2.4.1 Immunity tests - input and output ports

Environmental phenomena	Test specification	Units	Basic standard	Test procedure	Acceptance criteria	Remarks
Conducted disturbance induced by radio-frequency fields Amplitude modulated	0.15 – 80 10 80 50	MHz V (unmod, rms) % AM (1 kHz) ohms Source impedance	EN 61000-4-6	EN 61000-4-6 See note 1	See 15.2 and note 1	See note 2
Fast transients	5/50 5 2 2/2.5	Tr/Th ns kHz repetition frequency kV (peak) kV/kHz	EN 61000-4-4	IEC 60255-22-4	IEC 60255-22-4	
1 MHz burst  Differential mode Common mode	1 75 400 200 1 2,5	MHz frequency Tr ns Hz repetition frequency ohms Source impedance kV (peak) kV (peak)	IEC 60255-22-1	IEC 60255-22-1	IEC 60255-22-1	
Surge Differential mode Common mode	1,2/50 (8/20) 1 2 42	Tr/Th ms kV charge voltage kV charge voltage ohms Source impedance	EN 61000-4-5	EN 61000-4-5	See 15.2	See note 3
Insulation	2 5	kV/DC 1 Minute kV impulse 1,2/50us; 0.5J	IEC60255-5	IEC60255-5	IEC60255-5	
Damped oscillatory wave Differential mode Common mode	0.1/1/10/50 1 2.5	MHz kV kV	IEC 61000-4-12	IEC 61000-4-12	See 15.2	See note 4
<p>NOTE 1 The test procedure given in EN 61000-4-6 and the acceptance criteria given in 7.2 will be superseded by that given in EN 60255-22-6 when it is published.</p> <p>NOTE 2 Except for the ITU broadcast frequency band: 47 MHz - 68 MHz where the level is 3 V.</p> <p>NOTE 3 Applicable only to ports interfacing with cables, the total length of which according to the manufacturer's functional specification may exceed 10 m.</p> <p>NOTE 4 10 and 50 MHz is for GIS applications relevant</p>						

### 10.2.5 Immunity tests - functional earth port

Environmental phenomena	Test specification	Units	Basic standard	Test procedure	Acceptance criteria	Remarks
Conducted disturbance induced by radio-frequency fields Amplitude modulated	0,15 – 80 10 80 150	MHz V (unmod., rms) % AM (1 kHz) ohms Source impedance	EN 61000-4-6	EN 61000-4-6 See note 1	See 15.2 and note 1	See note 2 & 3
Fast transients	5/50 5 2	Tr/Th ns kHz repetition frequency kV (peak)	EN 61000-4-4	IEC 60255-22-4	IEC 60255-22-4	See note 3

NOTE 1 The test procedure given in EN 61000-4-6 and the acceptance criteria given in 7.2 will be superseded by that given in EN 60255-22-6 when it is published.

NOTE 2 Except for the ITU broadcast frequency band: 47 MHz - 68 MHz where the level is 3 V.

NOTE 3 Applicable only to ports interfacing with cables, the total length of which according to the manufacturer's functional specification may exceed 3 m.

### **10.3 Insulation Resistance**

Insulation resistance >100MΩ 500V DC

### **10.4 Mechanical Robustness**

Vibration test per IEC 60255-21-1

Shock response and withstand test per IEC 60068-2-2

Seismic test per IEC 60068-2-30

### **10.5 Climatic Conditions**

Cold test per IEC 60068-2-1

Dry heat test per IEC 60068-2-2

Damp Heat and Cycling test per IEC 60068-2-30

## 11 Connection Diagram

### 11.1 REF542*plus* with mechanical binary I/O

Example of REF542*plus* base version with one mechanical binary I/O version 3. Extension up to two additional mechanical binary I/O version 3 possible. Other configurations of the analog input board available, e.g mixed configuration for transformer and sensor connection.

Note: Please connect the right polarity on BO02.

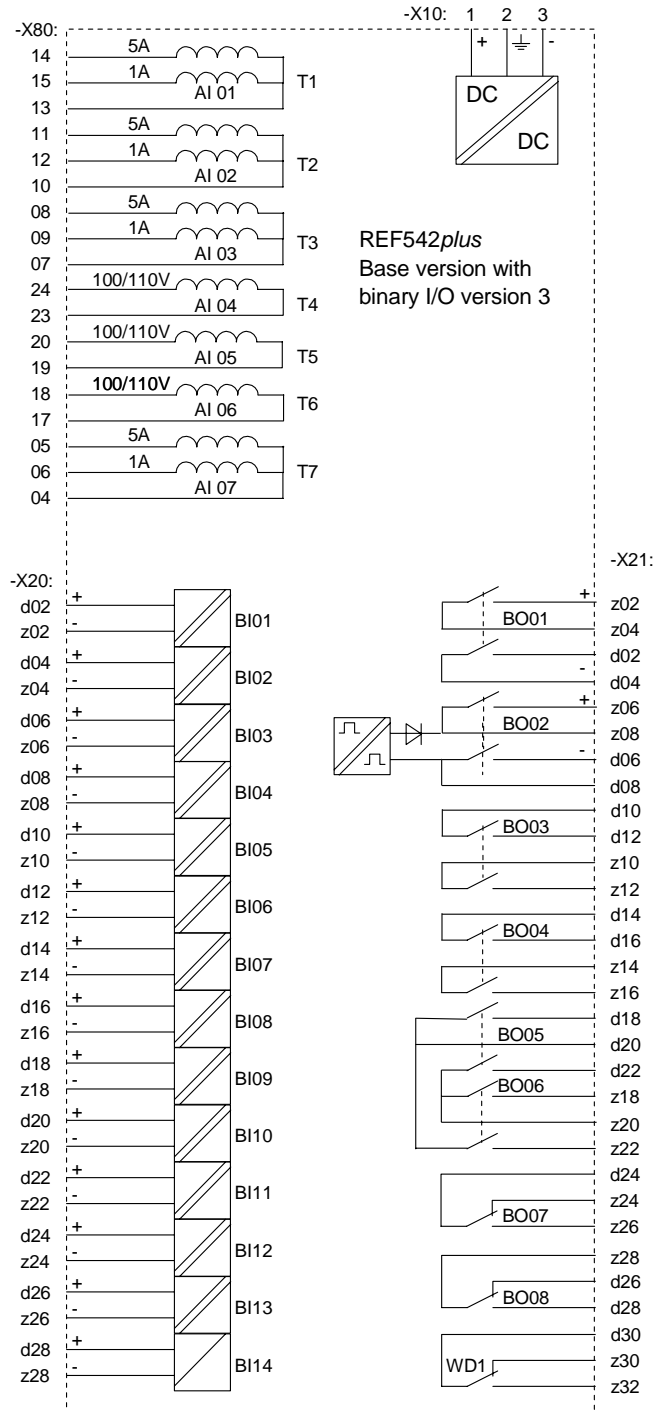

Extension with second additional mechanical binary I/O version 3

Note: Please connect the right polarity on BO 10

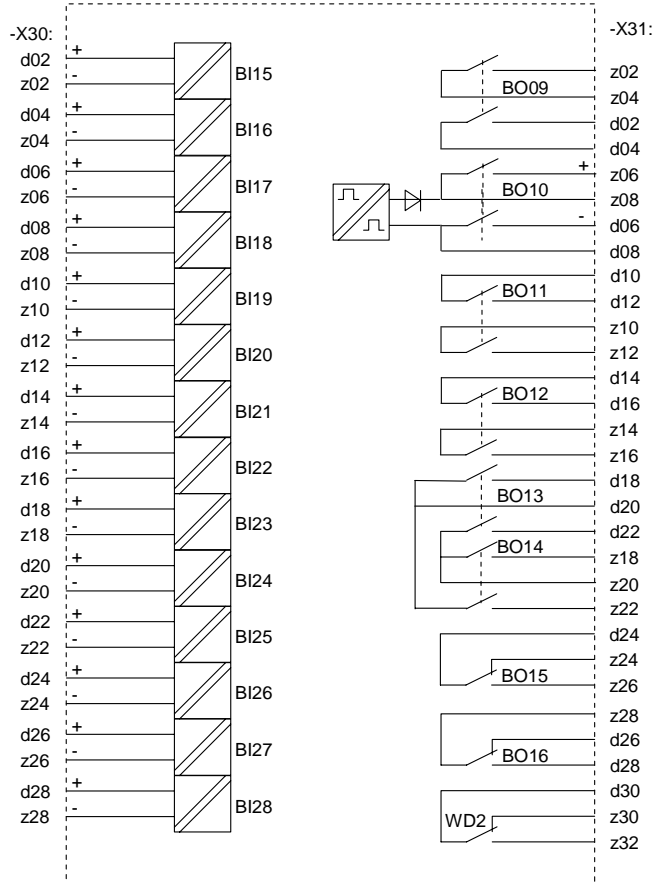

Extension with third additional mechanical binary I/O version 3

Note: Please connect the right polarity on BO 18

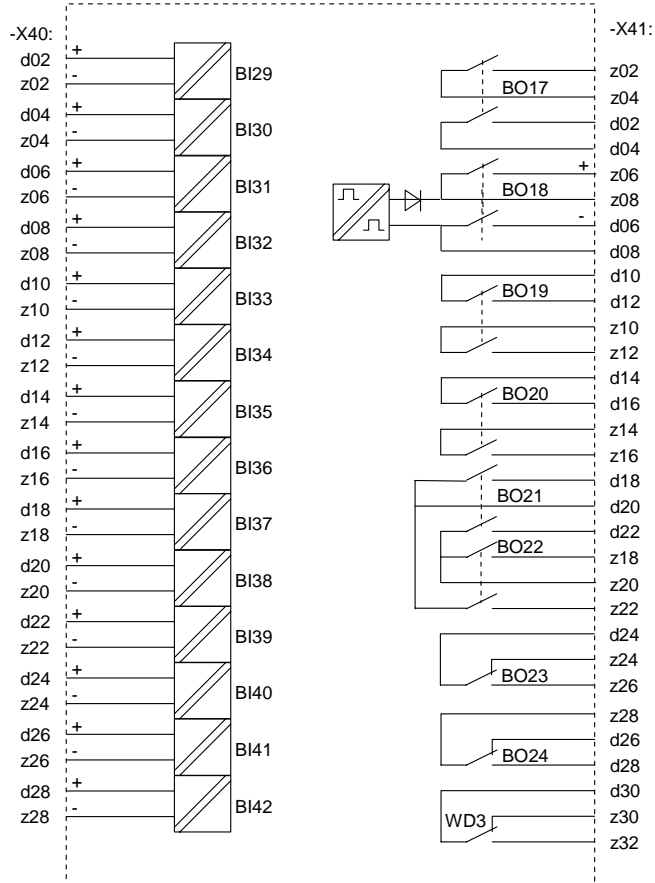

## 11.2 REF542plus with solid state binary I/O

Example of REF542plus base version for sensor connection with one solid state binary I/O version 3. Extension up to two additional solid state binary I/O possible. Other configuration of the analog input board available, e.g mixed configuration for transformers and sensors connection.

Note: Please connect the right polarity

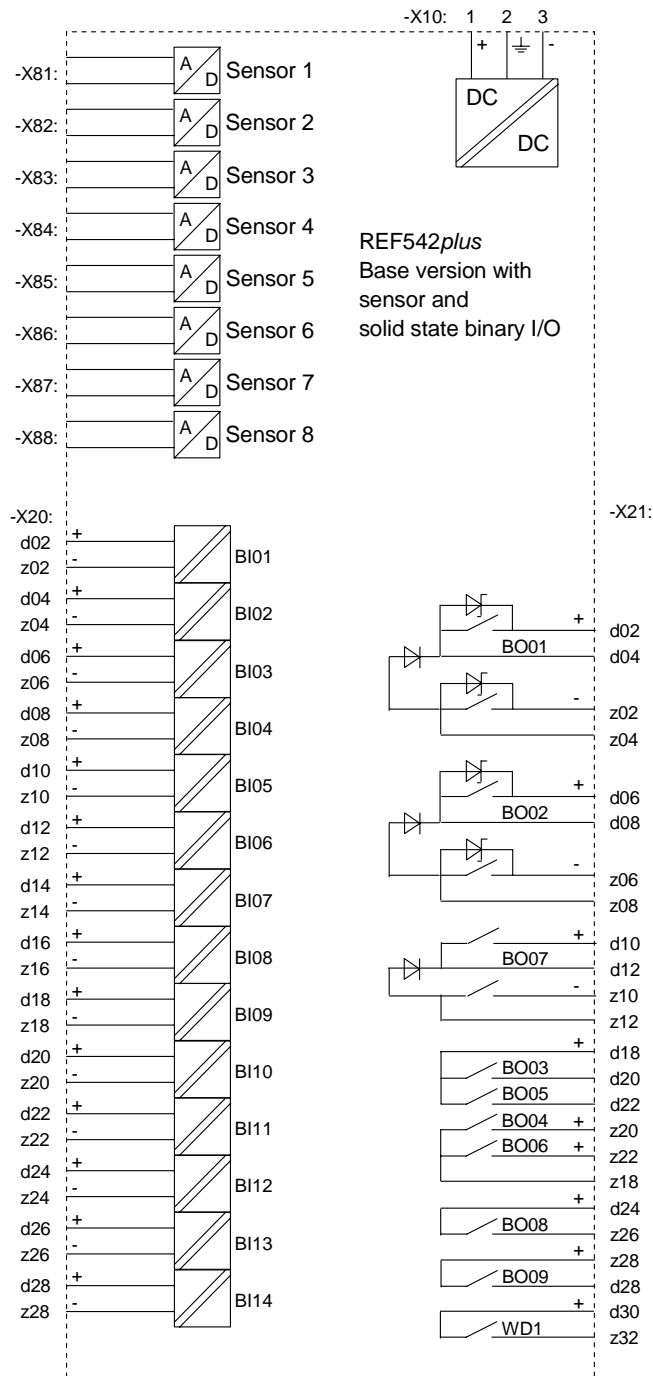

Extension with second solid state binary I/O.

Note: Please connect the right polarity

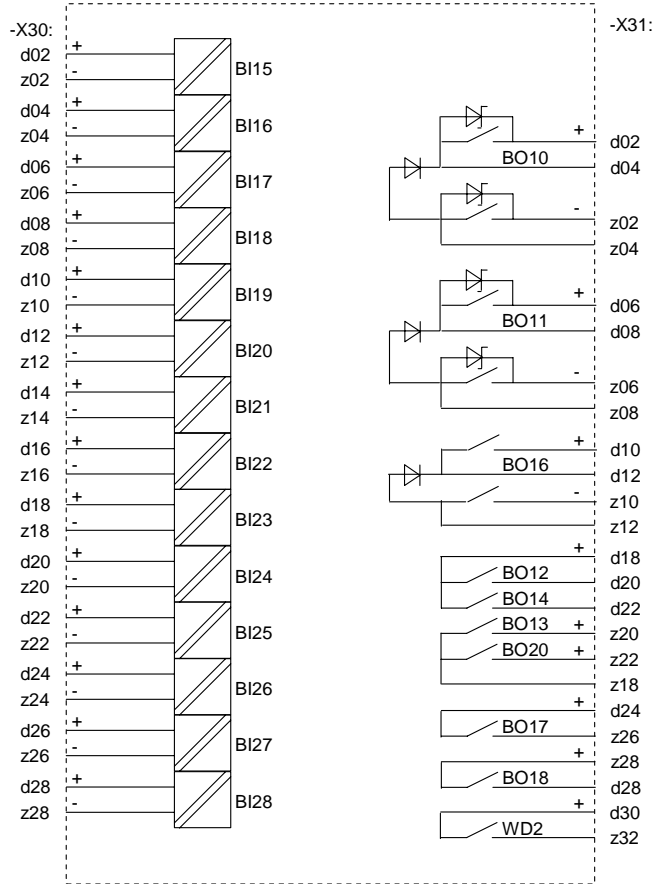

Extension with third additional solid state binary I/O

Note: Please connect the right polarity

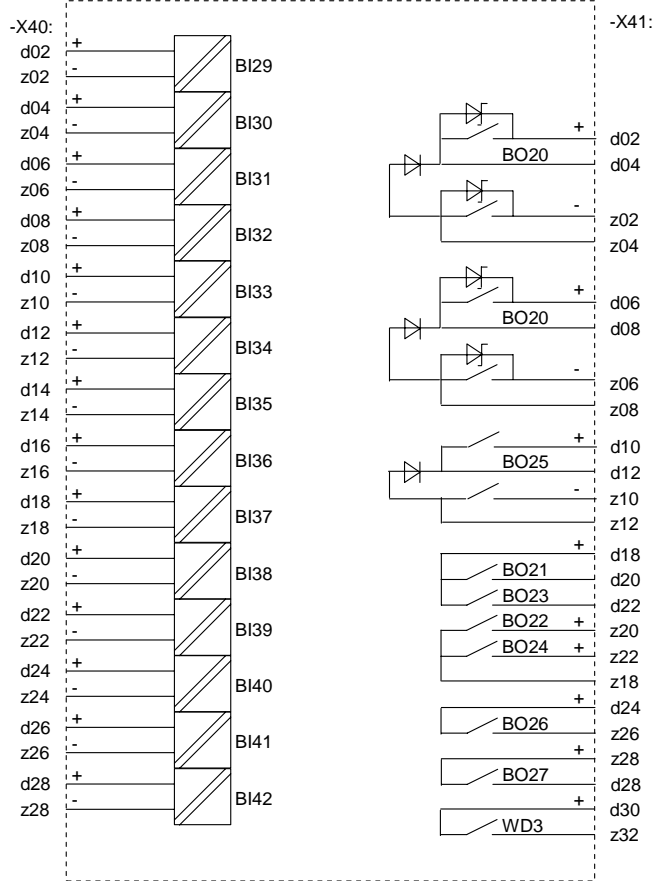

## Product information:

Technical Marketing  
ABB Calor Emag Mittelspannung GmbH  
Oberhausener Str. 33  
D-40472 Ratingen  
Phone: +49 (0) 2102 12 1046  
Fax: +49 (0) 2102 12 1808 1046  
E-mail: [hendro.rijanto@de.abb.com](mailto:hendro.rijanto@de.abb.com)  
Internet: <http://www.abb.de/calor>