



ABB Automation Inc.  
Substation Automation and Protection Division  
Coral Springs, FL  
Allentown, PA

Descriptive Bulletin  
41-126M

August 2000

Device Number: 50/51/51N/50N/79

## MICROSHIELD O/C™ Multiphase Time-Overcurrent Relay

---

---



### Highlights

- ANSI and IEC Time Overcurrent Curves
  - RMS Response
  - Programmable Input and Output Contacts
  - Optional Four Shot Recloser
  - Small Size and Available Bezel Kits Easily Retrofit Electromechanical and Solid State Relays
  - Optional Front RS-232 and Rear RS-485 Communication Ports
  - Resident Communications Protocols include Modbus® and ASCII
  - Complete Current, Voltage, Power, and Frequency Metering Package with KWHr, KVARHr, and Power Factor
  - Demand Values
  - Fault Recording
  - Event Capture
  - LCD Display and Full Function Keypad are Standard
  - Drawout Unit and CT Shorting
  - Meets all Applicable ANSI C37.90 and IEC 255 Standards
  - UL Listed
- 
-

### Product Description

The Microshield O/C relay is an advanced microprocessor based unit that was designed to provide high value three phase and ground overcurrent protection and optional circuit breaker auto-reclosing. Applications include distribution feeders, transformers, line protection back-up, motor protection, and others. The Microshield O/C provides monitoring, metering, and fault recording as well as protection. The Microshield O/C can be applied with voltage transformers (VTs) connected for operation at 69 or 120 volts AC phase-to-ground (Wye), 120 volts or 208 volts AC phase-to-phase (Open-Delta). (Other voltages such as 110v or 100v nominal are also suitable and easily accommodated.)

The unit is packaged in a steel case suitable for conventional flush mounting on panel. It can also be semi-flush mounted by the use of available case spacers when unit depth is a concern. Available bezels make retrofit of older electromechanical and solid state relays possible. The full draw-out design allows for quick removal without the need for removal of hardware. The microprocessor based logic along with the power supply, VT's and CT's can be totally withdrawn from the case and interchanged with other cases without the need for re-calibration. CT shorting bars are an integral part of the unit case. All connections to the Microshield O/C are made at terminals on the rear of the unit.

### Protective Functions

The Microshield O/C contains the protective elements necessary for medium voltage circuit overcurrent protection. Its applications include distribution feeder protection, line backup protection, motor overcurrent protection, and transformer overcurrent protection. The dual phase-time-overcurrent elements allow the user to design a composite curve; for example for motor protection applications to provide locked-rotor and overload protection. A summary of the elements follows.

- Three-phase time-overcurrent elements (51P, 51LT)
- Ground time-overcurrent protection (51N)
- Phase instantaneous overcurrent (50P)
- Ground instantaneous overcurrent protection (50N)
- ANSI Trip and reset times conform to IEEE C37.112

### Built-in Time-Overcurrent Curves

<u>ANSI 51P/51N</u>	<u>IEC 3I&gt;2/IN&gt;</u>
Extremely Inverse	Extremely Inverse
Very Inverse	Very Inverse
Inverse	Inverse
Short Time Inverse	Long Time Inverse
Long Time Extremely Inverse	
Long Time Very Inverse	
Long Time Inverse	
Definite Time 1	
Definite Time 2	

<u>ANSI 51LT</u>	<u>IEC 3I&gt;1</u>
Long Time Extremely Inverse	Long Time Inverse
Long Time Very Inverse	
Long Time Inverse	
Very Long Time Extremely Inverse	
Very Long Time Very Inverse	
Very Long Time Inverse	
Long Definite Time	

### Instantaneous Curves

<u>ANSI 50P/50N</u>
Short Time Inverse
Definite Time 1
Standard (no delay)
Definite Time 2

### Optional Recloser (No Charge Option)

The Microshield O/C optional recloser function may be used wherever post fault auto-reclosing of a circuit breaker is desired. The optional recloser features contained in the Microshield O/C are as follows.

- Programmable up to 4 Shots
- Selectable instantaneous overcurrent cutout function
- Programmable open interval times.
- Reset Timer
- Maximum Recovery Timer
- Maximum Reclosures to Lockout
- Zone Sequence Coordination
- External Reclose Initiate
- Internal and External Reclose Enable (43a)
- Close Fail Timer
- Cold Load Timer
- Can be used as a stand alone recloser via external reclose initiate input

## Metering

The Microshield O/C contains a complete current metering package. With the optional voltage inputs the metering function is significantly enhanced.

### Without optional VT inputs

- Single-phase current values
- Demand value for single-phase currents

### With optional VT inputs

- Single-phase current values
- Demand value for single-phase currents
- Single-phase voltage values (phase-to-phase if open-delta VT's are used)
- Three-phase kilowatts
- Three-phase kiloVARs
- Three-phase kilowatt-hours
- Three-phase kiloVAR-hours
- Power factor
- Frequency
- Demand value for three-phase kilowatts
- Demand value for three-phase kiloVARs

## Records

The Microshield O/C contains both fault and event recording capability:

- Recording of 128 events - stored in non-volatile memory
- Events are time and date tagged
- Recording of 32 faults stored in non-volatile memory
- Included in each record is the Record Number, Time and Date, Single-phase Current Values, and Single-phase Voltage Values (phase-to-phase if open-delta PT's)

## User Interface

- Easy to use MMI with 2 line by 16 character display
- Operation Indicators for Status, Pickup, Time Trip, and Instantaneous Trip

The Microshield O/C contains a Man-Machine Interface (MMI) as a standard feature. The MMI is used for local viewing and changing of settings, record retrieval, and metering. It contains a 2 row by 16 character backlit liquid crystal display (LCD). Six keys: "C" (clear) "E" (enter), "↑" (scroll up or increase value), "↓" (scroll down or decrease value), "←" (move cursor left) and, "→" (move cursor right) are used for all MMI operations. An easy to follow menu system allows for quick and easy navigation.

The MMI LCD continuously displays primary system currents Ia, Ib, Ic, and In. Obtaining other metering, record, and setting information is as easy as pressing the "E" (enter) key and following the menu system.

## Communications

The Microshield O/C has the capability to communicate over an RS-232 or RS-485 communication link. One front RS-232 and one rear RS-485 communications port is provided on the unit when ordered with the communications option.

Both ASCII and Modbus® protocols reside in the Microshield O/C as standard. These two protocols are selectable at both front and rear ports. The front communications port is non-addressable while the rear port has addressing capability in both ASCII and Modbus® modes. The rear port addressing capability lends itself to multiple device networks. In the case where a star-connected RS-232 network is used, an RS-232 to RS-485 converter must be installed with the Microshield O/C.

To set the communications protocol type, simply open the Communication Menu from the front panel MMI and select the desired option for each port.

The Microshield O/C internal communications hardware contains a single serial port designed to be switched from the front RS-232 connector to the rear RS-485 terminations and back when required. The serial port will normally operate from the rear RS-485 port until it detects that a switch has been requested. This is accomplished by entering the "Operations" Menu on the MMI and scrolling to the "Enable Front Port" item. Set the "Front Port" to <ON>. At this time the rear RS-485 terminal will become inactive until the front port is turned off or the Microshield O/C detects no activity on the front port for one hour. At this time, rear RS-485 communications will resume.

Both communications ports can be configured independently of one another. This means that the Protocol, Baud Rate, and Frame are set separately.

## Microshield Time Overcurrent Relay

---

Access the communication settings through the “Show Settings” or Change Settings”, then “Comm” MMI Menu selections. All settings relating to the front port will be preceded by “FP:” and all rear port settings will be preceded by “RP:”. Both ports support the same settings features except the address. The Address setting although not preceded by “RP:” or “FP:” applies only to the rear port for both ASCII and Modbus modes and the front port for the Modbus mode only.

Baud rates of 1200 to 19200 are supported by the relay.

### ASCII Menu System and Fast Commands

The ASCII protocol contained in the Microshield O/C was designed to be used in two modes:

**Mode 1:** A menu system designed to be user friendly for walk up type connection of a personal computer. The operator is not required to carry a protocol document or instruction manual to set the relay or to retrieve data.

**Mode 2:** “Fast” ASCII commands can be used for automated raw data retrieval.

### ASCII Menu System

To access the ASCII Menu System, connect the computer RS-232 port to the Microshield O/C front port through a null modem cable and start a terminal emulation program. Set up the PC port to match the baud rate and frame set in the Microshield O/C. Press the Enter key then type “menu” on the PC and the MicroshieldO/C will respond with the Main Menu. From the Main Menu are sub-menus to access the Microshield O/C functions and data. Figure 1 shows the ASCII Menu structure.

### Discrete ASCII Commands (fast commands)

The Microshield O/C ASCII system is designed to be applied in an automated data retrieval and control system. The fast ASCII protocol supports all data and control points contained within the Microshield O/C. For a copy of the Microshield O/C Automation Technical Guide, contact ABB at 1-800-634-6005. It is also available on the ABB website ([www.abbus.com/papd](http://www.abbus.com/papd)).

### Modbus Protocol

The Microshield O/C contains Modbus® ASCII protocol. Both front RS-232 and rear RS-485 ports can selectively utilize the Modbus protocol. The Modbus protocol is a register based protocol that was developed by Modicon for use in PLC based communications. It is an open protocol that has become popular with various system integrators in Distribution Automation systems and SCADA applications. Modbus register assignments and other useful information can be found in the MSOC Automation Technical Guide.

### Programmable Inputs and Outputs

#### Programmable Inputs

The Microshield O/C contains two physical inputs “IN1” and “IN2”. These physical inputs are where external connections are made such as circuit breaker auxiliary inputs, control switch inputs, and SCADA inputs.

The MSOC has a number of Logical Inputs which can be assigned to a Physical Input. A selection of “Unmapped”, IN1, IN2, “IN1 @ IN2” (AND condition), or “IN1 + IN2” (OR condition) can be made. Table 1 lists the available logical inputs.

**Table 1 - Logical Inputs**

51LT	Torque-Control
51P	Torque-Control
50P	Torque-Control
51N	Torque-Control
50N	Torque-Control
52A	CB Aux.Contact
52B	CB Aux.Contact
	Zone Seq Coordination Enable
	TRIP
	CLOSE
79	Drive-to-Lockout
79	Enable
79	Initiate
	Reset Seal-In Alarms

## Programmable Outputs

The Microshield O/C contains three or five physical outputs depending on the catalog number ordered. If the unit is ordered with the optional VT inputs, three physical outputs are present. If the unit is ordered without the VT inputs, five physical outputs are present. The outputs are “TRIP”, “OUT1”, “OUT2”, “OUT3” and “OUT4”. These physical outputs are where external connections are made such as circuit breaker trip and close, alarm outputs, and SCADA outputs.

The Microshield O/C contains a number of Logical Outputs which may be assigned to physical outputs. If more than one logical output is assigned to a physical output, an OR condition will exist for that contact. Table 2 lists the available logical outputs.

**Table 2 - Logical Outputs**

51LT Trip
51P Trip
50P Trip
51N Trip
50N Trip
OR of all Overcurrent Elements
Pickup Alarm
Relay Failure Alarm
Circuit Breaker Failure Alarm
Reclose Program In Progress
Recloser Lockout Alarm
Breaker Maintenance Check Required
Recloser Disabled
Maximum Reclosures Reached
TRIP
CLOSE

## Programmable Master Trip Contact

The master trip contact is the physical contact to which all the protective elements are mapped, and on which the recloser state-machine is based. The MicroshieldO/C has the ability to include or exclude any of the protective elements from the master trip contact. For example, this would be useful where it is desired to operate a lockout relay when an instantaneous trip (50P) occurs, but reclose for a timed trip (51P). In this case the 50P element would be disabled from the master trip contact and re-mapped to one of the programmable output contacts.

## Casing and Optional Accessories

The Microshield O/C relay is packaged in a steel case and provides:

- Fully drawout construction with automatic CT secondary shorting
- Standard screw terminals suitable for ring lugs

The relay outline drawing is shown in Figure 2. For applications where the depth behind the panel is limited, a semiflush mounting kit is available that provides a spacer that is 0.75 inch [19mm] thick.

The panel drilling and cutout is shown in Figure 3 and the rear terminal block arrangement in Figure 5.

A dust and mist proofing kit consisting of a gasketed clear plastic front cover and a panel gasket is available (Figure 6). This kit is suitable for use with or without the semi-flush mounting kit (Figure 7).

For retrofit applications, accessory mounting kits are available (Figures 8-11). These kits provide adaptor plates and hardware to allow mounting the Microshield O/C in an existing panel cutout for a variety of electromechanical relays.

# Microshield Time Overcurrent Relay

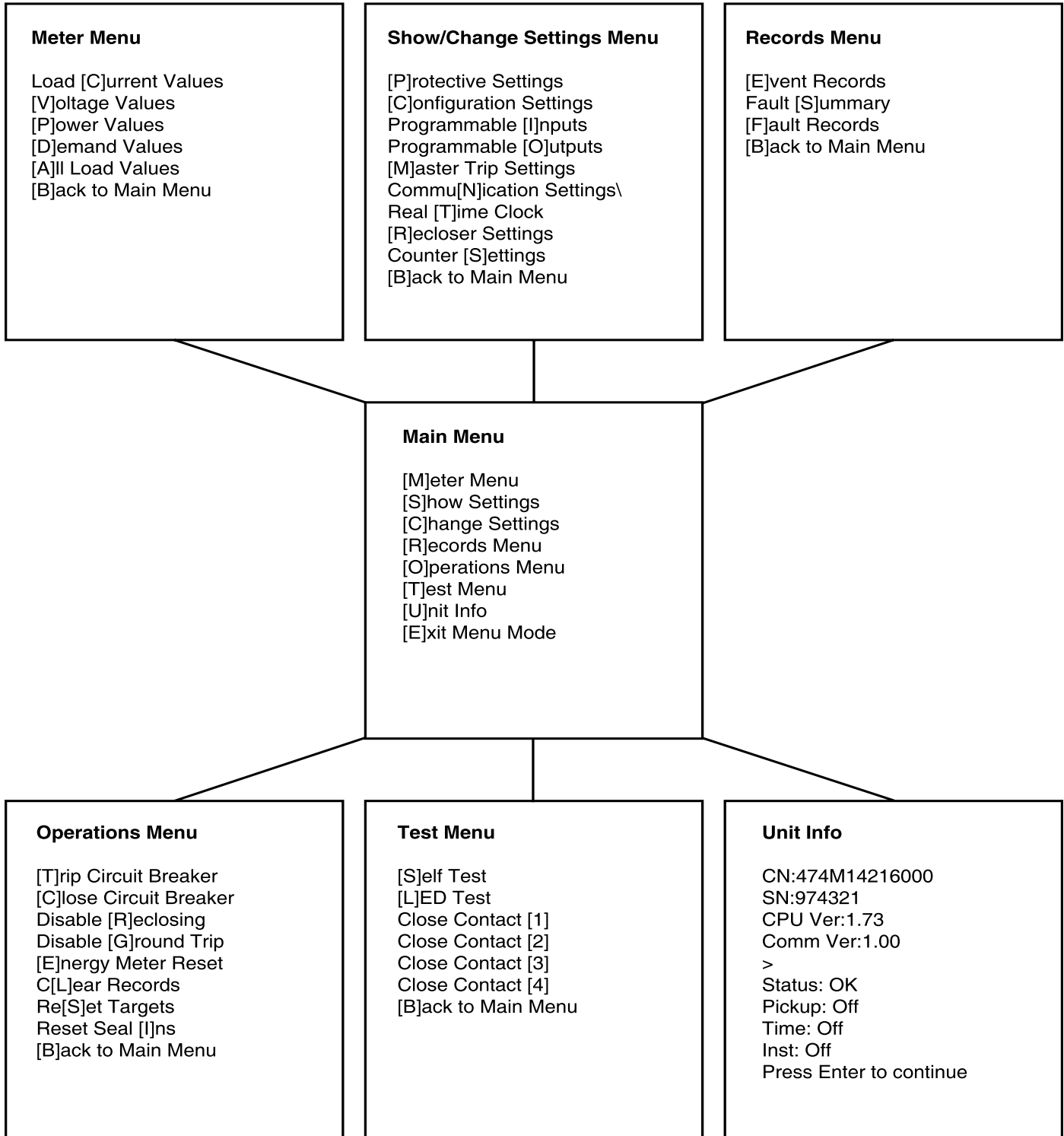

Figure 1. ASCII Menu System

## Specifications

### Current Input Circuit Ratings (50 or 60 Hertz)

Setting Range	Burden	Max. Continuous	One Second	I nom Metering
1.5 - 12 A	0.0004 VA @ 5 A	15 A	450 A	5 A
0.5 - 4 A	0.0008 VA @ 5 A	15 A	450 A	1.67 A
0.3 - 2.4 A	0.0001 VA @ 1 A	3 A	100 A	1 A
0.1 - 0.8 A	0.0002 VA @ 1 A	3 A	100 A	0.33 A

### AC Voltage Input Circuit Ratings (50 or 60 Hertz)

- Burden: 0.04 VA for V-n at 120 Vac

### Input Ratings

- Wye Connection: 160 Vac Continuous, 480 Vac for 10 sec
- Delta Connection: 260 Vac Continuous, 480 Vac for 10 sec

### Contact Input Circuit Burdens (at terminals 5 and 6)

- 18 - 60 Vdc rated unit: 0.08 VA maximum
- 60 - 150 Vdc rated unit: 0.52 VA maximum
- 150 - 300 Vdc rated unit: 2.1 VA maximum

### Output Contact Ratings (all contacts)

- 30 amperes tripping
- 5 amperes continuous
- 0.25 ampere inductive break @ 125 Vdc or 0.1 ampere inductive break @ 250 Vdc

### DC Control Power Requirements

Available Ranges	Max. Continuous Drain	Initial Startup Current
18 - 60 Vdc	5 VA	Consult Factory
60 - 150 Vdc	5 VA	0.1 ampere per volt max. over range*
150 - 300 Vdc	5 VA	Consult Factory.

\* Decay to nominal in 0.8 seconds

### Time-Overcurrent Pickup

Setting Range	Setting Increment
1.5 - 12 A	0.25 A
0.5 - 4 A	0.10 A
0.3 - 2.4 A	0.05 A
0.1 - 0.8 A	0.01 A

### Time-Dial Setting

Setting Range	Increment
1-10	0.1

### Time-Current Characteristic Curves

- Equations for curves given in the instruction book
- Transparent curves to be available—consult factory

### Instantaneous Overcurrent Pickup

Setting Range	Increment
1-20X of Time-Overcurrent Pickup	0.1X

### Sampling Rate

- 8 samples per cycle per analog input

### SWC and Fast Transient

- Per ANSI C37.90.1 and IEC 255-22-1 class III and 255-22-4 class IV for all connections except communications

### Impulse

- Per IEC 255-5 for all connections except communications

### Dielectric

- 3150 Vdc for 1 second, all circuits to ground except communications ports per IEC 255-5. 2333 Vdc for 1 second, for rear port only

### Radio Frequency Interference

- Per ANSI C37.90.2-1995 (35V/M complete sweep)

## Microshield Time Overcurrent Relay

---

### Temperature

- 40 to +85 degrees C (operating temperatures below 0 degrees C may impede the LCD display contrast)

### Humidity

- Per ANSI C37.90. Up to 95% non-condensing

### Metering Tolerances (temperature range of -20 to +55° C)

Function	Tolerance
Ammeter	±1% of Inom (for I from 10% to 2x Inom)
Voltmeter	±1% of full scale (120 Vac)
Wattmeter	±2% of IxV (for I from 10% to 2x Inom)
VAr Meter	±2% of IxV (for I from 10% to 2x Inom)
Energy Meters (WattHr, VArHr)	±2% of IxV (for I from 10% to 2x Inom)
Frequency Meter	±0.05 Hertz

### Nominal Metering Current

Input Rating	Inom
1.5 - 12A	5A
0.5 - 4A	1.67A
0.3 - 2.4A	1A
0.1 - 0.8A	0.33A

### Protection Tolerances

Function	Pickup	Dropout	Timing (Whichever is greater)
51LT/51P/51N	±5% of setting	98% of setting	±7%, or ±1 cycle
50P/50N	±10% of setting	98% of setting	±7%, or ±1 cycle

### Weight

- Unboxed: 7.5 lbs (3.4kg)
- Boxed for shipping: 10 lbs (4.6kg)

### Additional Information Available on Request

Instruction Book IB 7.2.1.7-16

MSOC Automation Technical Guide TG 7.2.1.7-16

Technical Support: Tel 800-634-6005 or 610-395-7333

Fax 610-395-1055

Faxback System: Domestic (Toll-free) 877-395-0721

International 610-395-7333 x5806

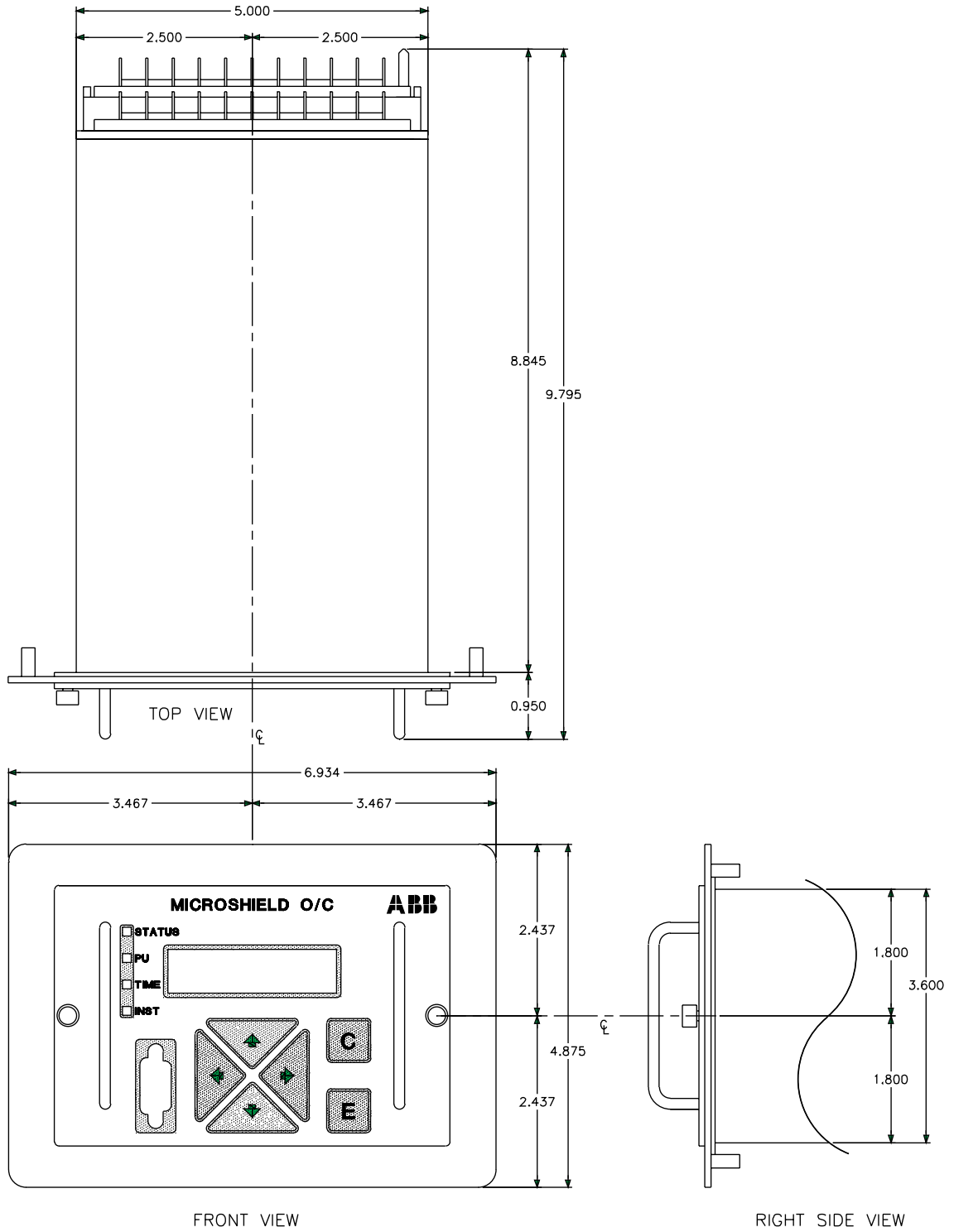

DIMENSIONS IN INCHES

Figure 2. Relay Outline

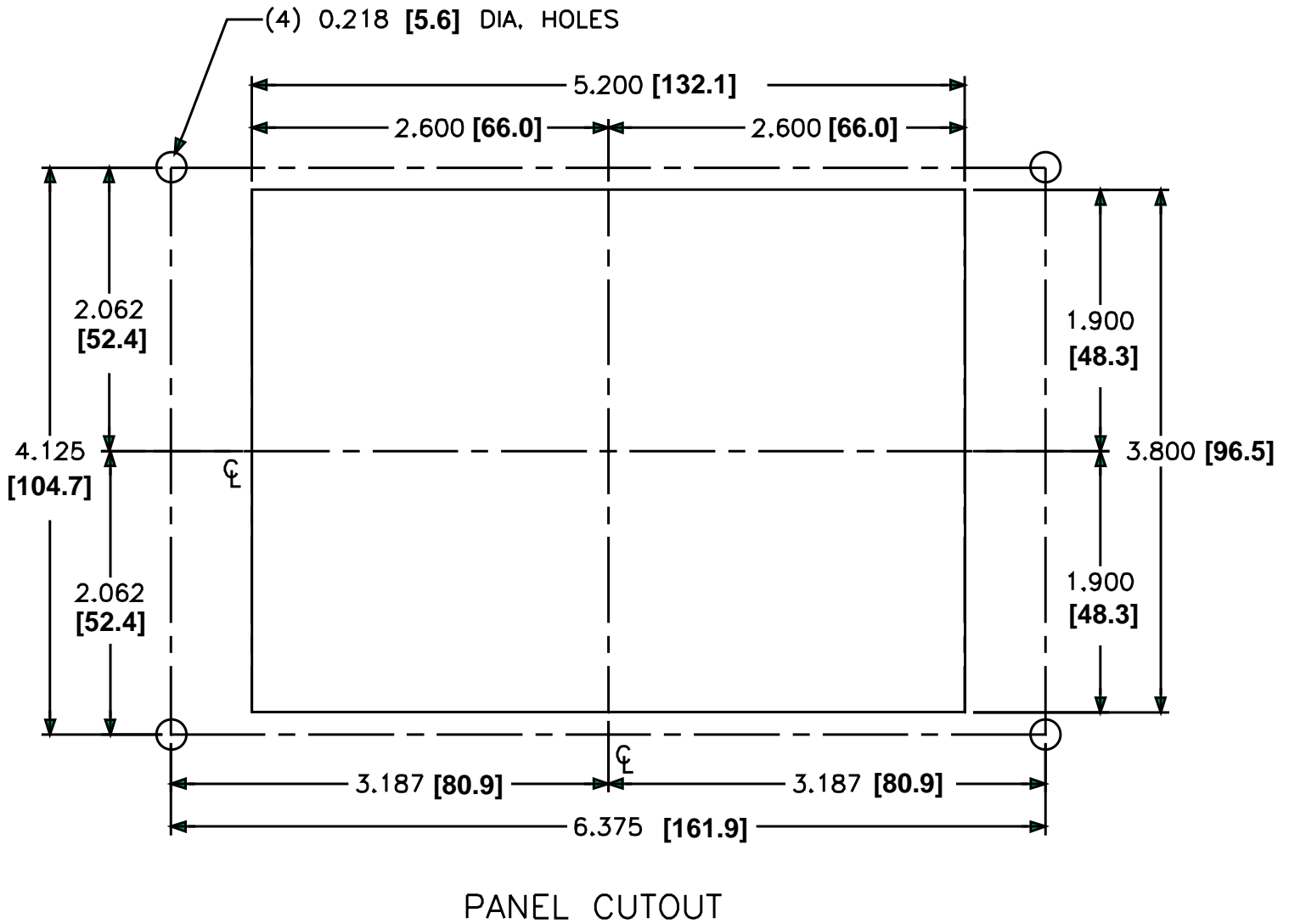
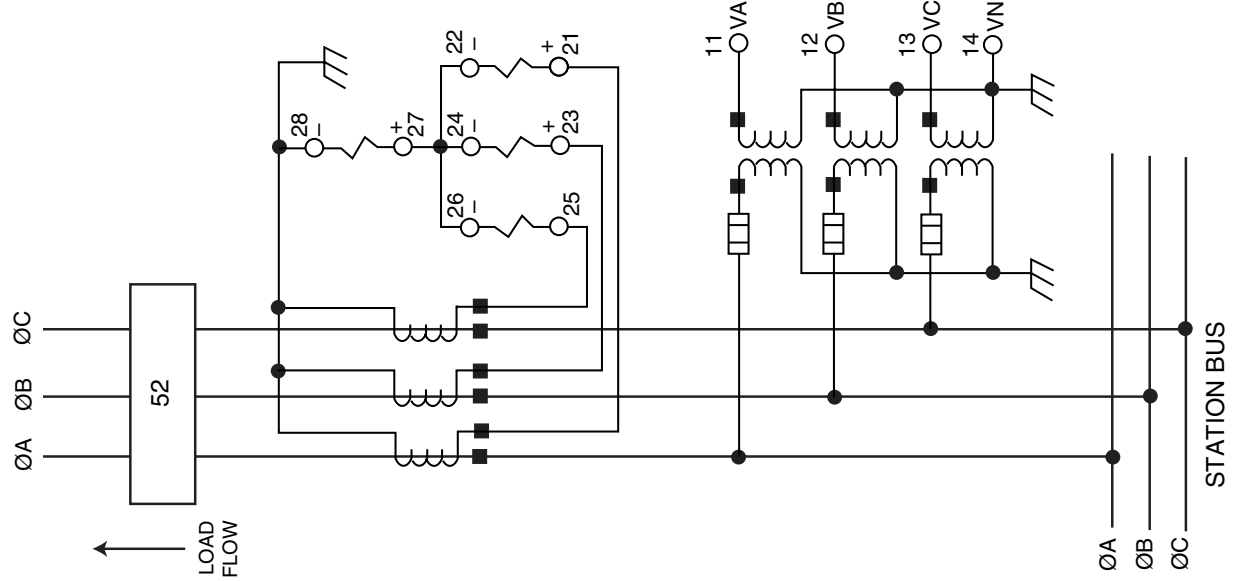
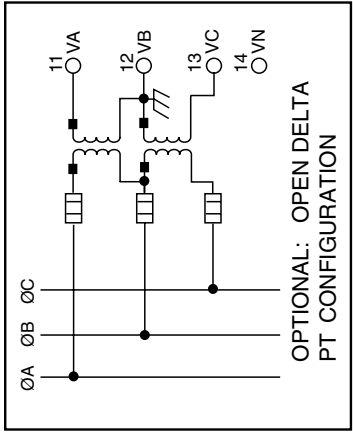
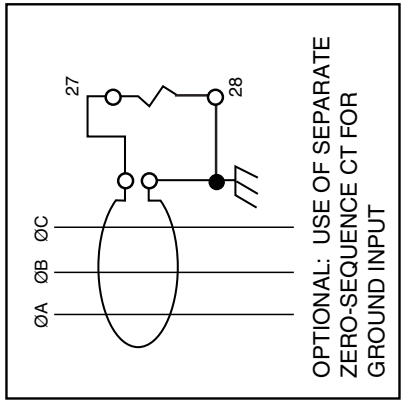

Figure 3. Panel Cutout (Circuit-Shield Style Bezel)



**External Connections Example**

1. Three-phase and Ground Overcurrent Protection.
2. Voltage Inputs for Metering
3. OUT 2 - Mapped to "FAIL". Will alarm, should relay self-diagnostics detect a relay problem. Connected to ANN (annunciator) or, RTU (remote term. unit).
4. OUT 1 - Mapped to "CLOSE".
5. IN 1 - Mapped to "52B".
6. IN 2 - Mapped to "50P" and "50N" enable.

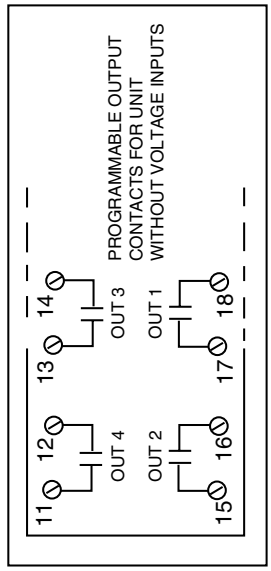
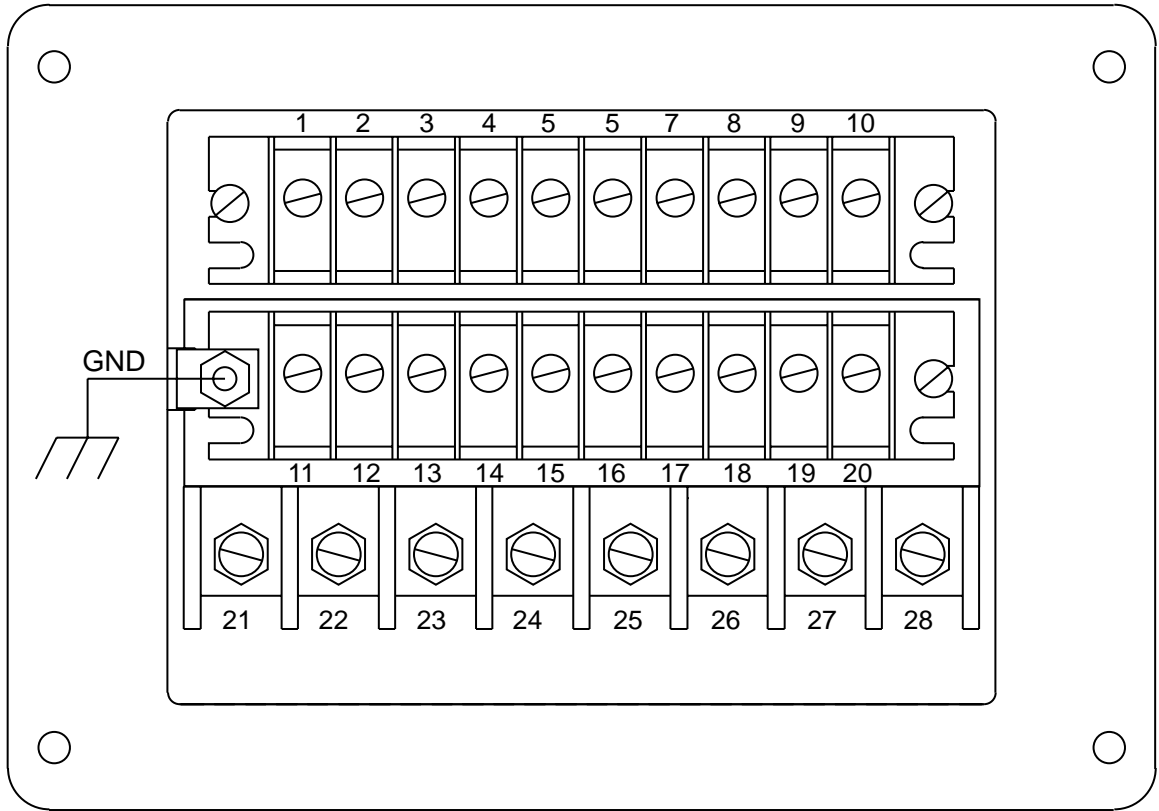

Figure 4. Typical Connections



**REAR VIEW**

**REAR TERMINAL BLOCK CONNECTIONS**

474MXX1X-XXXX

- 1 + CONTROL POWER
- 2 - CONTROL POWER
- 3 NO CONNECTION
- 4 - IN
- 5 + IN1
- 6 + IN2
- 7 NO CONNECTION
- 8 RS-485 COMMON
- 9 RS-485 -
- 10 RS-485 +
- 11 OUT4 N.O.
- 12 OUT4 N.O.
- 13 OUT3 N.O.
- 14 OUT3 N.O.
- 15 OUT2 N.O.
- 16 OUT2 N.O.
- 17 OUT1 N.O.
- 18 OUT1 N.O.
- 19 TRIP N.O.
- 20 TRIP N.O.
- 21 +Ia
- 22 -Ia
- 23 +Ib
- 24 -Ib
- 25 +Ic
- 26 -Ic
- 27 +In
- 28 -In

474MXX2M-XXXX

- 1 + CONTROL POWER
- 2 - CONTROL POWER
- 3 NO CONNECTION
- 4 - IN
- 5 + IN1
- 6 + IN2
- 7 NO CONNECTION
- 8 RS-485 COMMON
- 9 RS-485 -
- 10 RS-485 +
- 11 VOLTAGE ØA
- 12 VOLTAGE ØB
- 13 VOLTAGE ØC
- 14 VOLTAGE N
- 15 OUT2 N.O.
- 16 OUT2 N.O.
- 17 OUT1 N.O.
- 18 OUT1 N.O.
- 19 TRIP N.O.
- 20 TRIP N.O.
- 21 +Ia
- 22 -Ia
- 23 +Ib
- 24 -Ib
- 25 +Ic
- 26 -Ic
- 27 +In
- 28 -In

NOTE: The terminal wiring label below is applied to the relay case for field wiring of terminations and terminal block screw torque requirements.

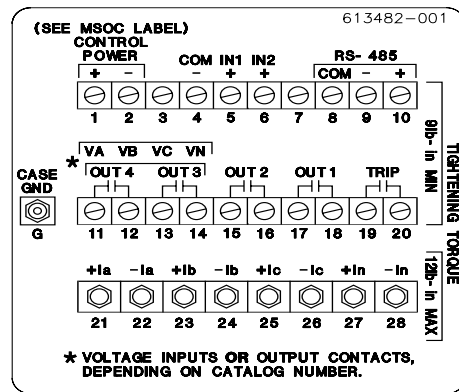

**Figure 5. Rear Terminal Description**

DUST AND MIST PROOF COVER  
REFERENCE EPL 613649-T13

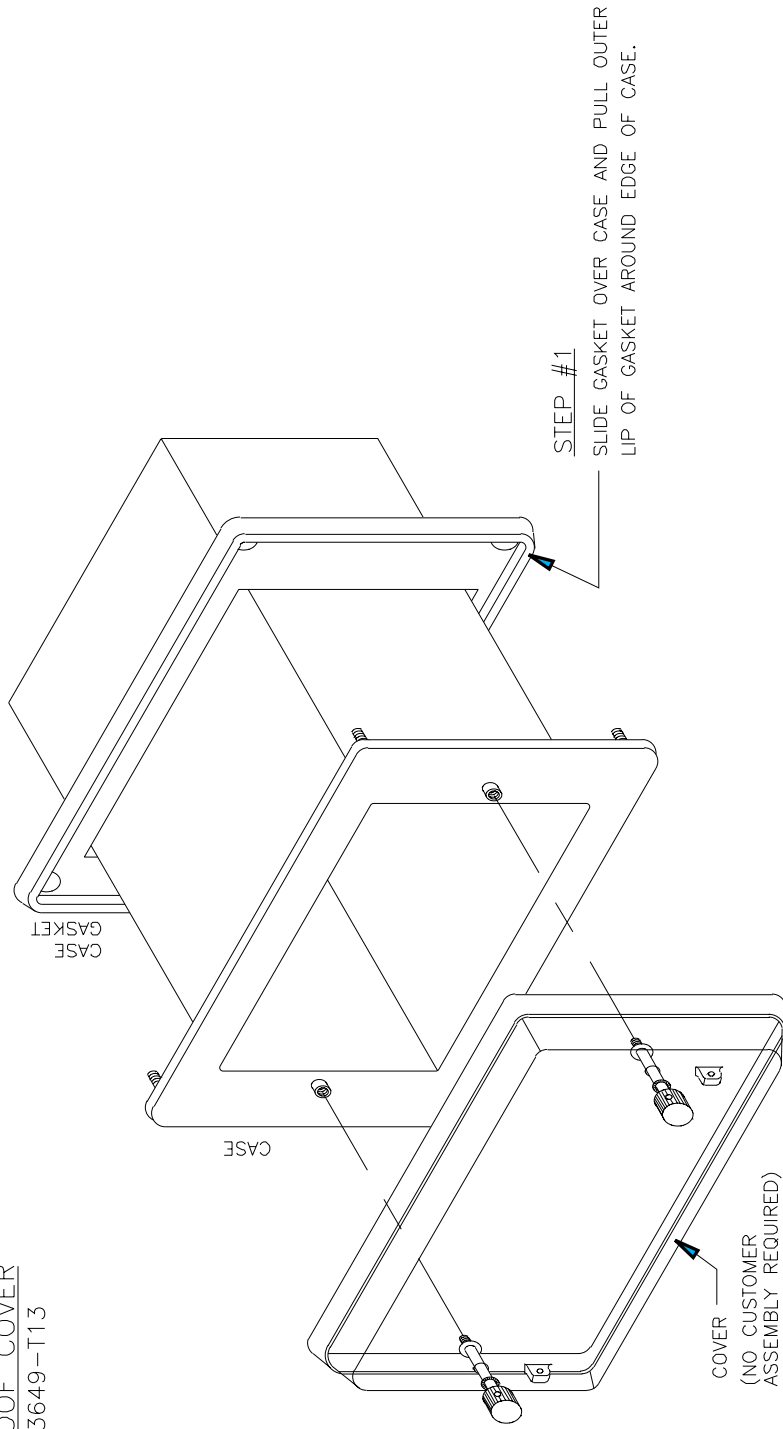
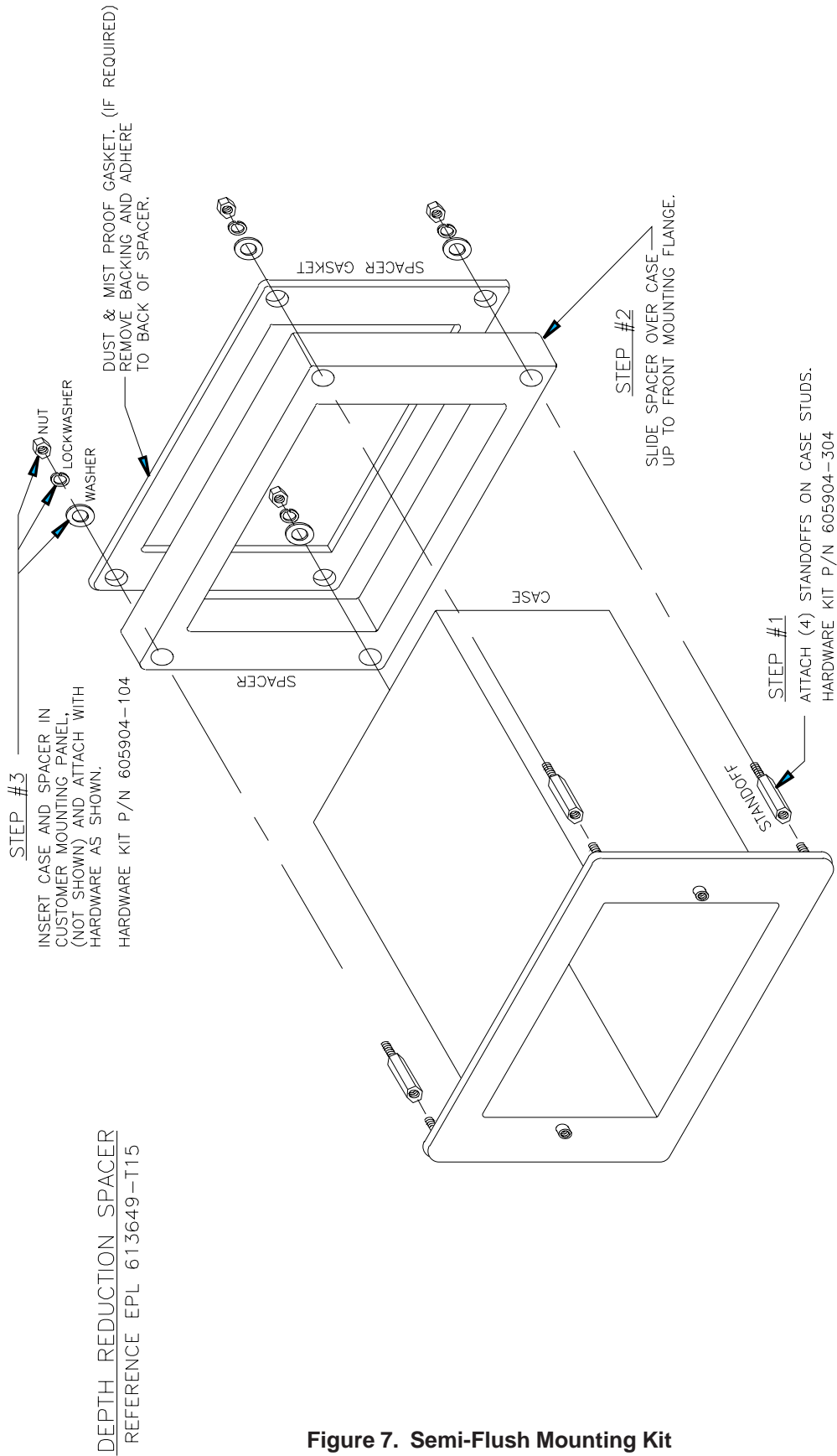

Figure 6. Dust and Mist Proofing Cover



**DEPTH REDUCTION SPACER**  
 REFERENCE EPL 613649-T15

**Figure 7. Semi-Flush Mounting Kit**

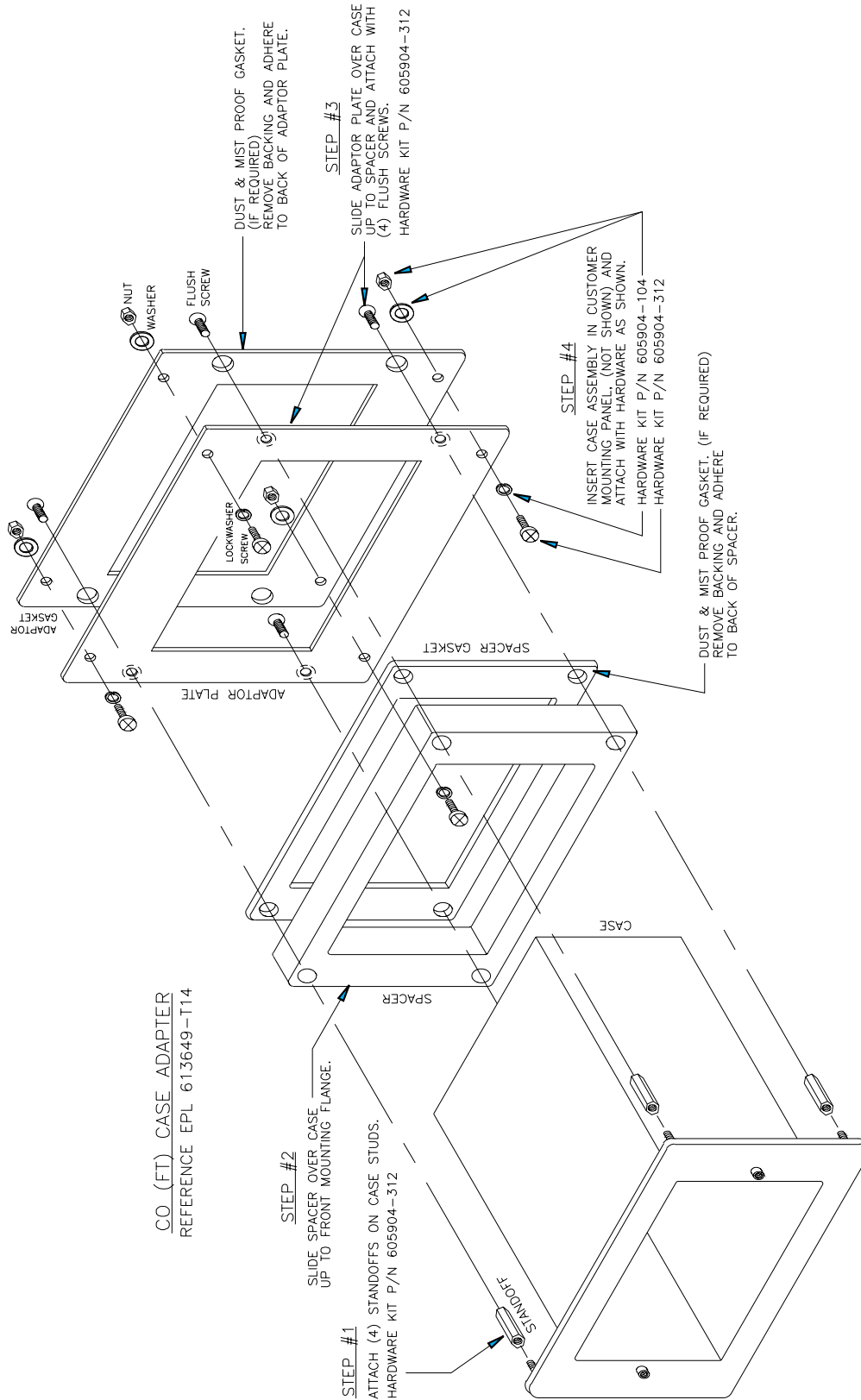

Figure 8. CO - FT11 Case Adapter Kit

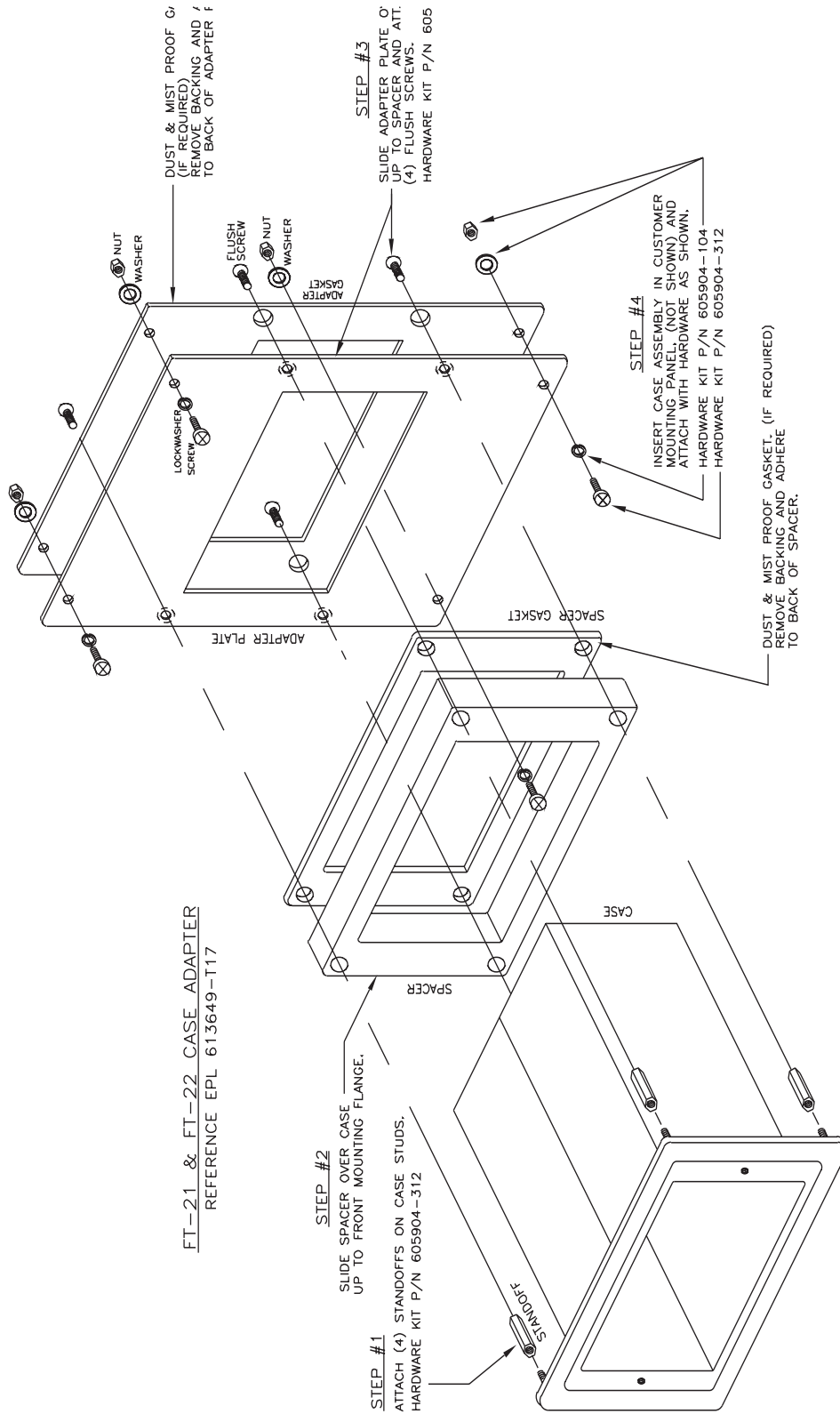
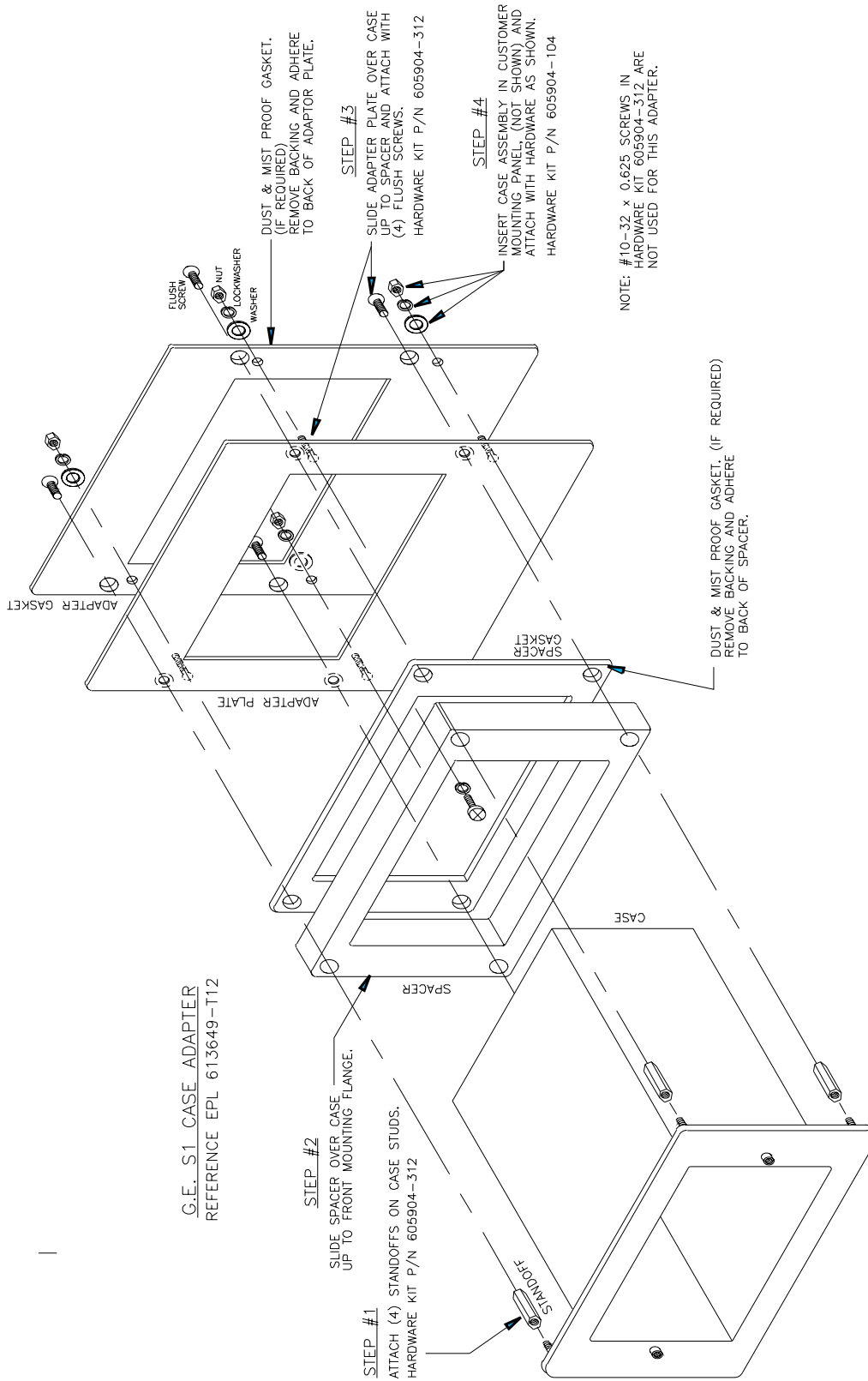

Figure 9. CO FT-21/22 Case Adapter Kit



G.E. S1 CASE ADAPTER  
REFERENCE EPL 613649-T112

Figure 10. IAC - S1 Case Adapter Kit

CASE EXTENDER

REFERENCE EPL 613649-T18

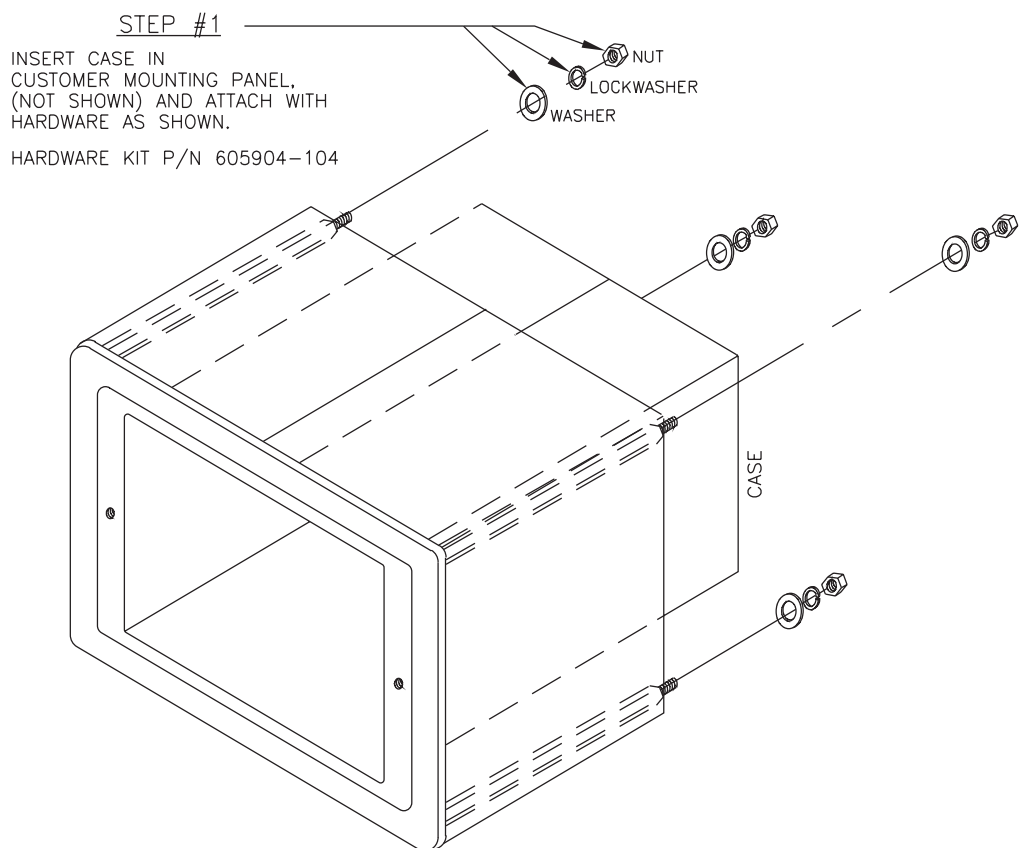

**Figure 11. MSOC Projection Mounting Kit**

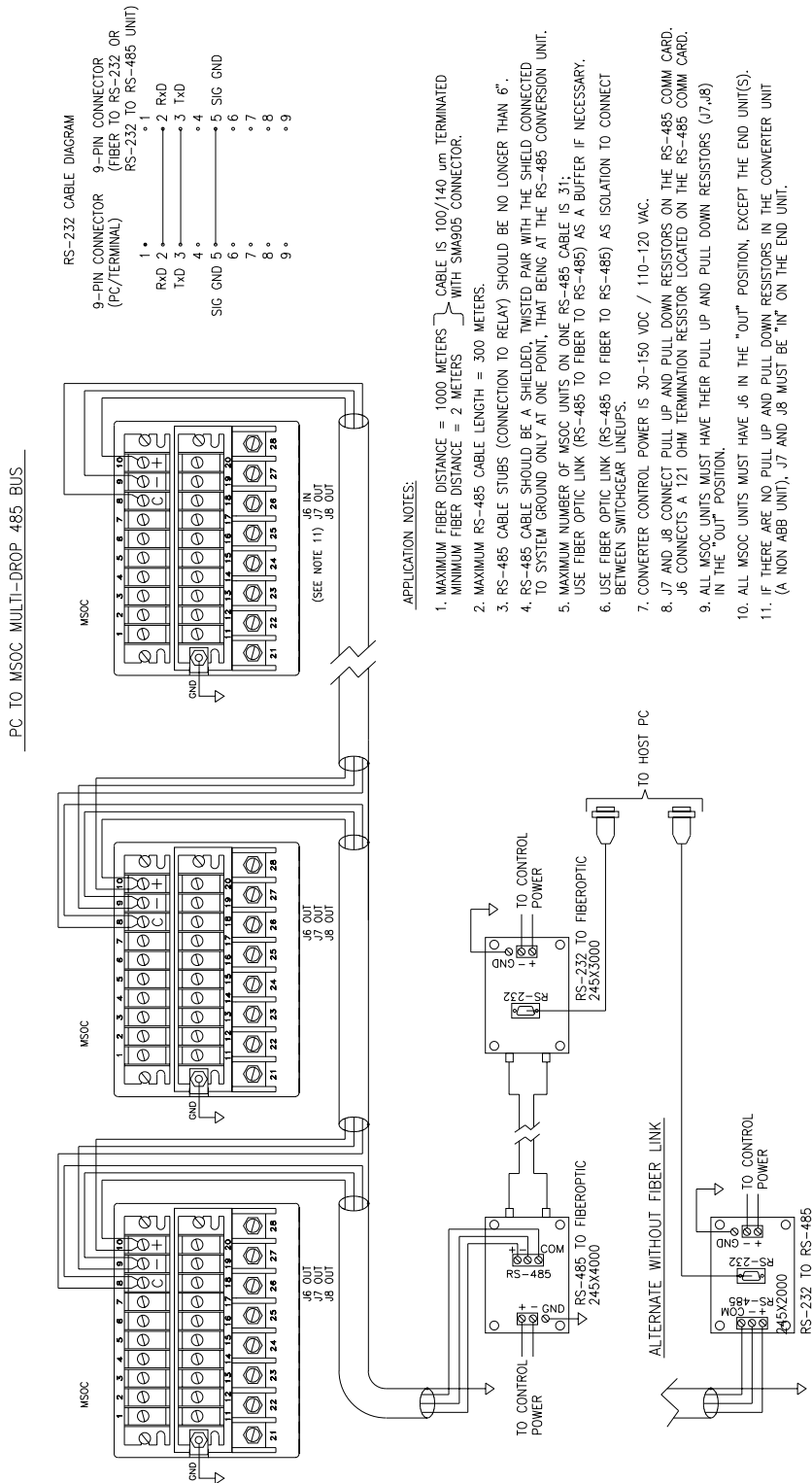

Figure 12. RS-232 and RS-485 Connections

**Ordering Selection Guide**

<b>Catalog Number</b>	<b>474</b>	<b>M</b>	<b>0</b>	<b>4</b>	<b>1</b>	<b>1</b>	<b>-</b>	<b>6</b>	<b>0</b>	<b>0</b>	<b>0</b>
<b>Enclosure</b>											
Circuit Shield™ Style	.....	M									
<b>Current Ranges</b>											
Phase			<u>Neutral</u>								
1.5-12.0 A			1.5-12.0 A	.....	0						
1.5-12.0 A			0.5-4.0 A	.....	1						
1.5-12.0 A			0.1-0.8 A	.....	2						
0.3-2.4 A			0.3-2.4 A	.....	4						
0.3-2.4 A			0.1-0.8 A	.....	5						
0.1-0.8 A			0.1-0.8 A	.....	6						
1.5-12.0 A			0.3-2.4 A	.....	7						
<b>DC Control Voltage Ranges</b>											
18 - 60 Vdc	.....				3						
60 - 150 Vdc	.....				4						
150 - 300 Vdc	.....				5						
<b>Configuration</b>											
1 Trip and 4 programmable output contacts	.....				1						
1 Trip, 2 programmable output contacts, voltage inputs	.....				2						
<b>Communications Port (No Charge Option)</b>											
None	.....				0						
Front RS-232 Port/Rear RS-485 Port	.....				1						
<b>Frequency in Hertz</b>											
50	.....							5			
60	.....							6			
<b>Time Curve Type</b>											
ANSI and IEC (curves only)	.....								0		
<b>Recloser (No Charge Option)</b>											
Without Recloser	.....									0	
With Recloser	.....										1
<b>Protocol</b>											
ASCII & Modbus®(available at front and rear ports)	.....										0

Modbus® is a registered trademark of Modicon Inc.