



# Station Automation COM600 3.5 MNS iS Connectivity (OPC) User's Manual



**Contents:**

<b>1. About this manual .....</b>	<b>5</b>
1.1. Copyrights .....	5
1.2. Trademarks .....	5
1.3. General .....	5
1.4. Document conventions .....	6
1.5. Use of symbols .....	6
1.6. Terminology .....	7
1.7. Abbreviations .....	8
1.8. Related documents .....	10
1.9. Document revisions .....	10
<b>2. Introduction .....</b>	<b>11</b>
2.1. Functional overview .....	11
2.2. IEC 61850 data modeling .....	11
2.3. Features .....	11
<b>3. Configuration .....</b>	<b>13</b>
3.1. About this section .....	13
3.2. Overview of configuration .....	13
3.3. MNS iS OPC Server installation and configuration .....	13
3.4. MNS iS OPC Connectivity Server Configuration using SAB600 .....	15
3.5. Configuring objects .....	16
<b>Index .....</b>	<b>17</b>



## 1. About this manual

### 1.1. Copyrights

The information in this document is subject to change without notice and should not be construed as a commitment by ABB Oy. ABB Oy assumes no responsibility for any errors that may appear in this document.

In no event shall ABB Oy be liable for direct, indirect, special, incidental, or consequential damages of any nature or kind arising from the use of this document, nor shall ABB Oy be liable for incidental or consequential damages arising from use of any software or hardware described in this document.

This document and parts thereof must not be reproduced or copied without written permission from ABB Oy, and the contents thereof must not be imparted to a third party nor used for any unauthorized purpose.

The software or hardware described in this document is furnished under a license and may be used, copied, or disclosed only in accordance with the terms of such license.

© Copyright 2011 ABB. All rights reserved.

### 1.2. Trademarks

ABB is a registered trademark of ABB Group. All other brand or product names mentioned in this document may be trademarks or registered trademarks of their respective holders.

### 1.3. General

This manual provides thorough information on the MNSis OPC Server and the central concepts related to it. You find instructions on how to configure the MNSis OPC Server related objects. The basic operation procedures are also discussed.

Information in this user's manual is intended for application engineers who configure the MNSis OPC Server.

This user's manual is divided into following sections:

#### **Introduction**

This section gives an overview of the MNSis OPC Server and its features.

## Configuration

In this section you will find an overview of configuration. You are given instructions on how to configure MNSis OPC Server related objects and the model of a substation or system.

### 1.4. Document conventions

The following conventions are used for the presentation of material:

- The words in names of screen elements (for example, the title in the title bar of a window, the label for a field of a dialog box) are initially capitalized.
- Capital letters are used for the name of a keyboard key if it is labeled on the keyboard. For example, press the ENTER key.
- Lowercase letters are used for the name of a keyboard key that is not labeled on the keyboard. For example, the space bar, comma key, and so on.
- Press CTRL+C indicates that you must hold down the CTRL key while pressing the C key (to copy a selected object in this case).
- Press ESC E C indicates that you press and release each key in sequence (to copy a selected object in this case).
- The names of push and toggle buttons are boldfaced. For example, click **OK**.
- The names of menus and menu items are boldfaced. For example, the **File** menu.
  - The following convention is used for menu operations: **MenuName > MenuItem > CascadedMenuItem**. For example: select **File > New > Type**.
  - The **Start** menu name always refers to the **Start** menu on the Windows taskbar.
- System prompts/messages and user responses/input are shown in the Courier font. For example, if you enter a value out of range, the following message is displayed:

```
Entered value is not valid. The value must be 0 - 30 .
```

- You can be asked to enter the string MIF349 in a field. The string is shown as follows in the procedure:

```
MIF349
```

- Variables are shown using lowercase letters:

```
sequence name
```

### 1.5. Use of symbols

This publication includes warning, caution, and information icons that point out safety-related conditions or other important information. It also includes tip icons to point out useful information to the reader. The corresponding icons should be interpreted as follows.



The electrical warning icon indicates the presence of a hazard which could result in electrical shock.



The warning icon indicates the presence of a hazard which could result in personal injury.



The caution icon indicates important information or warning related to the concept discussed in the text. It may indicate the presence of a hazard which could result in corruption of software or damage to equipment or property.



The information icon alerts the reader to relevant facts and conditions.



The tip icon indicates advice on, for example, how to design your project or how to use a certain function.

## 1.6. Terminology

The following is a list of terms associated with COM600 that you should be familiar with. The list contains terms that are unique to ABB or have a usage or definition that is different from standard industry usage.

Term	Description
Alarm	An abnormal state of a condition.
Alarms and Events; AE	An OPC service for providing information about alarms and events to OPC clients.
Data Access; DA	An OPC service for providing information about process data to OPC clients.
Data Object; DO	Part of a logical node object representing specific information, for example, status, or measurement. From an object-oriented point of view, a data object is an instance of a class data object. DOs are normally used as transaction objects; that is, they are data structures.
Data Set	The data set is the content basis for reporting and logging. The data set contains references to the data and data attribute values.

Term	Description
Device	A physical device that behaves as its own communication node in the network, for example, protection relay.
Event	Change of process data or an OPC internal value. Normally, an event consists of value, quality, and timestamp.
Intelligent Electronic Device	A physical IEC 61850 device that behaves as its own communication node in the IEC 61850 protocol.
Logical Device; LD	Representation of a group of functions. Each function is defined as a logical node. A physical device consists of one or several LDs.
Logical Node; LN	The smallest part of a function that exchanges data. An LN is an object defined by its data and methods.
LON	A communication protocol developed by Echelon.
LON Application Guideline for substation automation; LAG	A proprietary method of ABB on top of the standard LON protocol.
OPC	Series of standards specifications aiming at open connectivity in industrial automation and the enterprise systems that support industry.
OPC item	Representation of a connection to the data source within the OPC server. An OPC item is identified by a string <object path>:<property name>. Associated with each OPC item are Value, Quality, and Time Stamp.
Property	Named data item.
Report Control Block	The report control block controls the reporting processes for event data as they occur. The reporting process continues as long as the communication is available.
SPA	ABB proprietary communication protocol used in substation automation.
SPA device	Protection and/or Control Product supporting the SPA protocol version 2.5 or earlier.
Substation Configuration Language; SCL	XML-based description language for configurations of electrical substation IEDs. Defined in IEC 61850 standard.

## 1.7.

### Abbreviations

The following is a list of abbreviations associated with COM600 that you should be familiar with. See also 1.6, Terminology.

Abbreviation	Description
AE	Alarms and Events
ASDU	Application Service Data Unit
BRCB	Buffered Report Control Block

Abbreviation	Description
DA	Data Access
DMCD	Data Message Code Definition
DO	Data Object
GW	Gateway, component connecting two communication networks together
HMI	Human Machine Interface
IEC	International Electrotechnical Commission
IED	Intelligent Electronic Device
LAG	LON Application Guideline for substation automation
LAN	Local Area Network
LD	Logical Device
LMK	LonMark interoperable device communicating in LonWorks network. In this document, the term is used for devices that do not support the ABB LON/LAG communication.
LN	Logical Node
LSG	LON SPA Gateway
NCC	Network Control Center
NUC	Norwegian User Convention
NV	Network Variable
OLE	Object Linking and Embedding
OPC	OLE for Process Control
P&C	Protection & Control
RTS	Request To Send
SA	Substation Automation
SAB600	Station Automation Builder 600
SCL	Substation Configuration Language
SLD	Single Line Diagram
SNMP	Simple Network Management Protocol
SNTP	Simple Network Time Protocol
SOAP	Simple Object Access Protocol
RCB	Report Control Block
URCB	Unbuffered Report Control Block
XML	eXtended Markup Language

**1.8. Related documents**

Name of the manual	MRS number
COM600 User's Manual	1MRS756125

**1.9. Document revisions**

Document version/date	Product revision	History
A/17.6.2008	3.2	Document created
B/13.2.2009	3.3	Document revised
C/06.11.2009	3.4	Document revised
D/30.06.2011	3.5	Document revised

## 2. Introduction

### 2.1. Functional overview

MNS *iS* OPC server is used for the communication to the MLink devices. COM600 and MLink devices are physically connected together using the LAN connections. MNS *iS* OPC server is connected to the COM600 software using an MNS *iS* connectivity server. MNS *iS* connectivity server remodels and links the data from the MNS *iS* OPC server to the IEC 61850 data model used by the COM600 applications. OPC DA is used between the MNS *iS* OPC Server and the connectivity server.

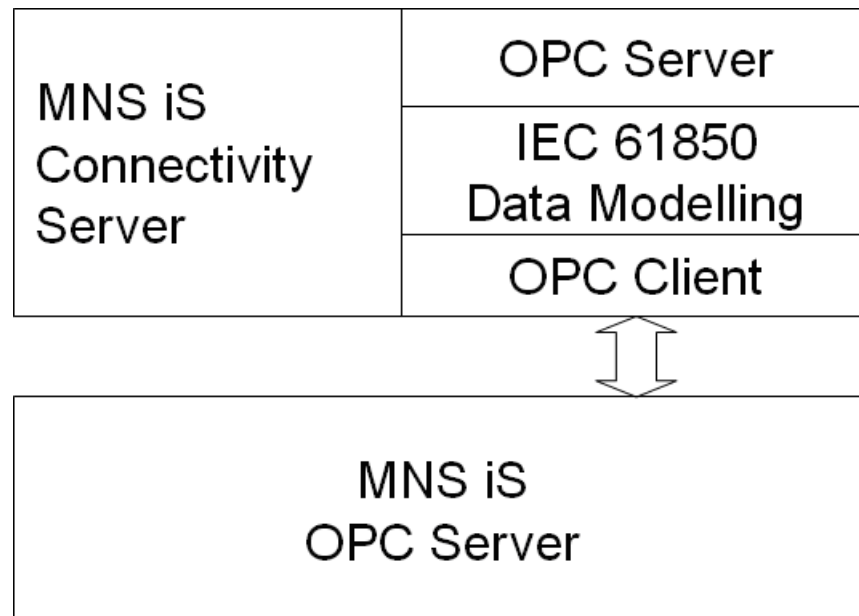

Figure 2.1-1 MNS *iS* connectivity server overview

### 2.2. IEC 61850 data modeling

IEC 61850 data modeling is described in further detail in section *IEC 61850 data modeling* of COM600 User's Manual.

### 2.3. Features

The MNS *iS* connectivity server supports the following features:

- OPC Data Access Server v. 1.0/2.0
- OPC Alarms and Events Server v. 1.10

- OPC Data Access Client v.2.0
- IEC 61850 data modeling

The following data can be used from MNS *iS* OPC DA Server in COM600:

- Measurement values
- Trip and alarm indications
- Device Status indications
- Communication status indications

Timestamps for data changes in the MNS *iS* OPC DA OPC server are not transferred from IEDs. They are created by the OPC server based on the computer system time.

The recommended maximum number of MControl devices that can be connected to one COM600 is 180.

## 3. Configuration

### 3.1. About this section

This section describes the installation and configuration of the MNS *iS* OPC server.

### 3.2. Overview of configuration

To commission COM600 MNS *iS*, install the MNS *iS* OPC Server to the COM600 computer. The COM600 MNS *iS* Connectivity Server configured using Station Automation Builder 600 (later referred to as SAB600).

The configuration of the MNS *iS* OPC Server prepares COM600 to communicate with the MNS *iS* devices and retrieving the data to the OPC server namespace. The connectivity server configuration links the data from the MNS *iS* OPC Server to COM600 framework, to be used with other COM600 functions like the HMI and gateway.

### 3.3. MNS *iS* OPC Server installation and configuration

#### Installing MNS *iS* OPC Server

To install the MNS *iS* OPC Server:

1. Run the executable file C:\ABB MNS *iS* OPC Server Installation Package\1TGE160005R0004\_ABB\_MNSiS\_OPC\_Server\_5\_4c Setup.exe.
2. At the end of the installation sequence, a dialog with the "Show the readme file" check-box is displayed. Clear the check-box or you will receive an error reporting that the installation failed. You can later select the readme file (ABB MNS *iS* OPC Server\_Readme.txt) from the C:\Program Files\ABB\ABB MNS *iS* OPC Server directory.
3. When the installation has been completed, run the register.bat file located in the same directory as the MNS *iS* OPC Server installation package. After that you are ready to configure the MNS *iS* OPC server.

#### DCOM Configuration

When configuring the MNS *iS* OPC server, run under COM600 user account

To modify the DCOM configuration, select:

**Start > Settings > Control Panel > Administrative Tools > Component Services > Component Services > Computers > My Computer > DCOM Config**

1. Right-click on **ABB MNS iS OPC DA Server** and select **Properties**.
2. Select **Identity** tab
3. Check **This user** option and enter COM600 to the User field and the correct password to the password fields.
4. Click **Apply** to accept the changes.

If the password of the COM600 user is changed later, for example, with SAB600 management tool, this password must be manually changed for the MNS iS OPC server as described above.

## Namespace Configuration

MNS iS OPC server software package has a service which scans the network for MLink devices. When MLink devices are found, they are added to the OPC server namespace. If a previously found device does not respond, it is removed from the namespace. In COM600 environment, it is preferable to maintain the namespace static and therefore the dynamic update of the namespace must be disabled during normal operation. Enable scanning only when new devices are added to, or permanently removed from the configuration. Only devices that are connected to COM600 should be available on the network when the scanning service is enabled. Otherwise all found devices are added to the namespace, which creates an unnecessary load to the OPC server.

To enable or disable scanning using the windows service management console in COM600:

1. Select **Start > Settings > Control Panel > Administrative Tools > Services**
2. Locate the file **MOPCSrv.exe** from the list and double-click it.
3. Change the **Startup** type to **Manual**.
4. Use the **Start** and **Stop** buttons the start and stop the service.

When the new devices are added or old ones are permanently removed, start the scanning service as explained above using the Service management console

1. Stop the OPC server by ending the **MNSiSDAS.exe** process using the task manager
2. Start the OPC server. The COM600 service restarts the OPC server automatically. You can also use third party OPC test client start the OPC server.
3. Wait until the scanning service has updated the changes to the configuration. You could use third party test client to verify that the namespace is correctly updated.
4. Stop the scanning service
5. Stop the OPC server
6. Restart the OPC server, check that the namespace is correct

### 3.4. MNS iS OPC Connectivity Server Configuration using SAB600

#### Building Object Tree

Building the object tree in the communication view of SAB600 is described in section *Building object structures* of COM600 User's Manual.

In the communication structure, the subnetwork object is used to group the MControl devices which are connected to separate MLink devices. If the communication status of the MLink is needed as an own signal, an own IED for the Mlink must be created as well. Below this IED an LD and LLN0 with Health mapped to the communication status must be created. MControl devices are presented as IEDs in the tree. The data from the MControls is modeled as data objects below logical nodes and logical devices. The LLN0 Health must be mapped to the communication status OPC item of the MNS iS OPC Server.

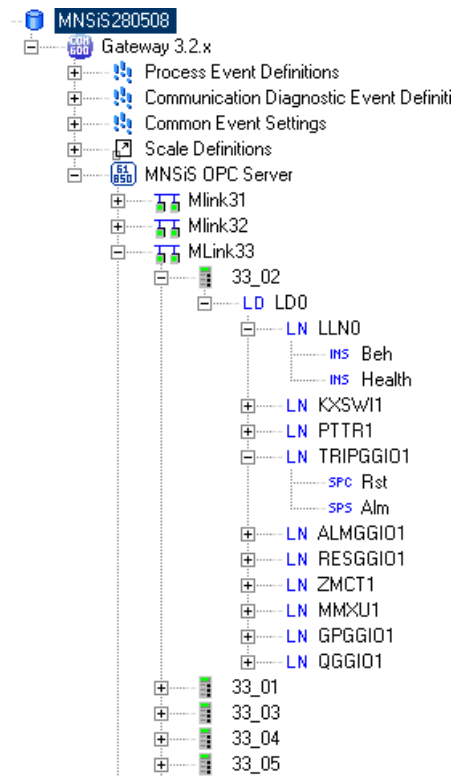

MNSiS\_object\_tree.png

Figure 3.4-1 MNS iS OPC server object tree example

## 3.5. Configuring objects

Server and subnetwork object do not normally need any change to the default values of the properties. On the IED object, the event definition for the device connection status is configured according to the needs of the project.

Data objects contain the OPC item paths to the MNS iS OPC server. This specifies the source data used to update the values of the data object. Below is an example of **SPS data** which gets its value from the **MLink33.2.DeviceStatus.GPI1** OPC item from the MNS iS OPC Server.

- Update Rate property specifies the maximum rate the OPC server updates the item.
- The shortest rate supported by the MNS iS OPC Server is 1000 ms.

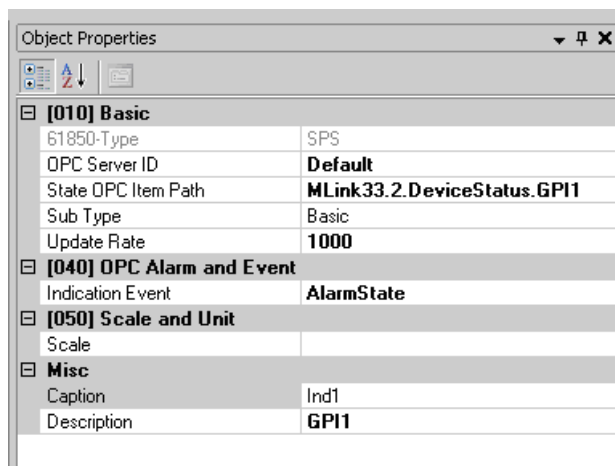

MNSiS\_object\_properties.png

Figure 3.5-1 An example of MNSiS object properties

## **Index**

### **C**

configuration	
DCOM .....	13
MNS iS Connectivity Server .....	13
MNS iS OPC Server .....	13
Namespace .....	13
configuring	
objects .....	16

### **I**

IEC 61850 data modeling .....	11
installation	
MNS iS OPC Server .....	13





# Contact us

## **ABB Oy**

### **Distribution Automation**

P.O. Box 699

FI-65101 VAASA, FINLAND

Tel. +358 10 22 11

Fax. +358 10 224 1094

## **ABB Inc.**

### **Distribution Automation**

655 Century Point

Lake Mary, FL 32746, USA

Tel: +1 407 732 2000

Fax: +1 407 732 2335

**[www.abb.com/substationautomation](http://www.abb.com/substationautomation)**