

Transformer Protection Unit 2000R

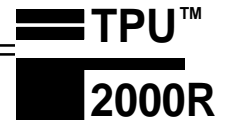

The TPU-2000R is an advanced microprocessor-based Transformer Protection Unit designed for use on 3-phase power transformers. The TPU-2000R provides sensitive high-speed differential protection for internal phase and ground faults as well as time and instantaneous overcurrent protection for auto-, two winding and three winding transformers. The user-selectable harmonic restraint setting prevents false tripping on magnetizing inrush and overexcitation.

The TPU-2000R can easily be set to operate based on the restraint curves of other electronic and electromechanical relays. This assures continuity with the user's past protective practices.

The phase compensation software setting eliminates the need for phase corrective wiring of the current transformer secondaries. The phase compensation setting is adjustable from 0 to 330 degrees, in 30 degree increments, allowing for most power transformer winding configurations.

The Harmonic Restraint record details the per-phase percent harmonic in each winding at the start and stop of a harmonic restraint condition so the restraint margin can be determined.

The 64 cycle per-phase event log and optional oscillographic record provide detailed system disturbance data.

Three groups of setting tables allow for on-line switching between groups for adaptive relaying techniques.

Separate pickup tap ranges and time-current curves are available for phase and ground overcurrent elements.

Features

- Four (4) selectable percentage restraint characteristics
- Three (3) selectable harmonic-restraint modes
- Ratio-matching taps with wide range and small step size decrease the percent mismatch to levels unobtainable by conventional relays
- Phase compensation for practically any main winding and current transformer secondary arrangement
- Six (6) overcurrent protective functions for each winding
- Programmable logic inputs and outputs
- Complete load current metering functions
- Menu-driven programming of settings
- Isolated communication ports provide superior remote communications
- Front and rear communications ports for simultaneous local and remote access
- Advanced 32 bit microprocessor technology
- The TPU-2000R is designed to permit complete electronic draw-out
- Models available for use with optical ct's.

Protective Functions

- Two or three winding, 3-phase differential current protection (87T & 87H)
- Three modes of harmonic restraint: 2nd, 2nd and 5th, all harmonics through the 11th
- Three-phase overcurrent protection (time and instantaneous) per winding (51P, 50P, 150P)
- Ground overcurrent protection (time and instantaneous) per winding (51N, 50N, 150N)
- Negative sequence overcurrent protection per winding (46)
- Three groups of setting tables: Primary, Alternate 1, and Alternate 2
- Eight programmable contact Inputs and six programmable output contacts with selectable delays of 0 to 60 seconds
- Nine user-selectable time-overcurrent characteristic curves
- Five instantaneous overcurrent characteristic curves
- Three optional user-programmable overcurrent curves

Metering & Records

- Oscillographic waveform capture and data storage capabilities
- Counters: differential trips, overcurrent trips, through-fault, through-fault kA summation for each phase, summation of through-fault duration in cycles
- Maximum and minimum demand amperes and demand power with time stamp for winding 1, winding 2 or winding 3 (if applicable)
- Per-phase current and voltage metering
- Differential fault records: last 16 trips
- Harmonic restraint records: last 32 events
- Through-fault records: last 32 events
- Operations records: last 128 operations
- Accumulation of transformer through-fault kA and duration
- Optional load profile records: per-phase demand currents for up to 40 days at 15 minute intervals, 160 days at 60 minute intervals
- Watt and VAR metering
- Watt hour and VAR hour metering

Note: The screens, displays and records shown in this product bulletin represent the 2 Winding Unit. Refer to the instruction book for additional information on the 3 Winding Unit.

Protective Functions

Protective Functions Summary

(per winding)

Differential Current Function: **87T**
 High Set Instantaneous Differential: **87H**
 (Unrestrained)
 Time Overcurrent Functions: **51** (One function for phase and one function for ground)
 Instantaneous Overcurrent Function: **50** (Two functions for phase and two functions for ground)
 Negative Sequence: **46**

Differential Current Function: 87T

The percentage differential restraint characteristic prevents operation until the differential current is greater than a certain percentage of the through current. This provides security against errors due to CT ratio mismatch, CT performance at high through-faults and operation of on-load tap changers.

Four Selectable Restraint Characteristics Curves

Tap ranges:

5-Amp CT: 2.0 to 9.0 A in 0.1 steps
 1-Amp CT: 0.4 to 1.8 A in 0.02 steps

0.1-Amp CT: 0.04 to 0.18 in 0.02 steps
 (For use with ABB Optical CT's)

Adjustable percentage differential with a linear slope of **15% to 60%** in 5% step increments with minimum sensitivity of 0.2 to 1.0 X per unit tap in 0.1 steps.

HU **30%** and HU **35%** characteristic curves with fixed minimum sensitivity of 0.3 and 0.35 per unit respectively

Selectable percentage differential slope of **15%, 25%, or 40%** Tap with fixed minimum sensitivity of 0.3 per unit.

Harmonic Restraint

Selection:

2nd, 2nd and 5th, or All Harmonics through the 11th

Range:

2nd Harmonic: 7.5% to 25% in 2.5% steps
 5th & All Harmonic: 15% to 40% in 2.5% steps
 Based on fundamental frequency

The fine adjustability of the tap settings allows you to minimize CT ratio mismatch. The adjustability of the percentage slope allows you to tailor the relay characteristic to your application.

The TPU-2000R allows for non-conventional Wye/Wye current transformer wiring for power transformers connected Delta/Wye. The Phase Angle Compensation setting is adjustable from 0° to 330° in 30° increments to allow the user to compensate through software for the phase shift through the power transformer windings. The relay also provides proper compensation for the chosen CT connections, which are entered in the configuration settings.

High Set Instantaneous Differential 87H (Unrestrained)

- 6 to 20 times the 87T tap setting in increments of 0.1

Time Overcurrent Functions: 51

One Phase setting and one Ground setting per winding

- Curve: Nine (9) ANSI time overcurrent curves and three (3) optional user-programmable characteristic curves (see Table 1).
- Pickup: 1 to 12 A in 0.1 increments or 0.2 to 2.4 A in 0.02 increments (based on catalog selection)
- Time dial selections: 1 to 10 in 0.1 steps
- Time delay selections: 0 to 10.0s in 0.1 steps (for Definite Time curve selection only)

Table 1. 2000R Time Overcurrent Curves

Curve Definition	
ANSI	
Extremely Inverse	
Very Inverse	
Inverse	
Short Time Inverse	
Definite Time	
Long Time Extremely Inverse	
Long Time Very Inverse	
Long Time Inverse	
Recloser Curve	
User 1*	* Only available with the user-programmable curve option.
User 2*	
User 3*	

Instantaneous Overcurrent Function: 50

(Two Phase settings and two Ground settings per winding)

50P and 50N

- Curve: Five (5) overcurrent and three (3) user programmable characteristic curves (see Table 2).
- Pickup: 0.5 to 20 x (51P and 51N Pickup setting)
- Time dial selections: 1 to 10 in 0.1 steps
- Time delay: 0 to 9.99s in 0.01 steps (Definite Time Curve only)

Table 2. Instantaneous Overcurrent Curves

Curve Definition
Standard Instantaneous
Inverse Instantaneous
Definite Time
Short Time Inverse
Short Time Ext. Inverse
(3) User-Progr. Curves

150P and 150N

- Pickup: 0.5 to 20 x (51P and 51N Pickup setting)
- Time delay: 0 to 9.99s in 0.01 steps (definite time)

Negative Sequence: 46 (per winding)

- Curve: Nine (9) time overcurrent and three (3) user programmable characteristic curves (see Table 1)
- Pickup: 1 to 12 A in 0.1 steps or 0.2 to 2.4 A in 0.02 steps (based on catalog selection)
- Time dial selections: 1 to 10 in 0.1 steps
- Time delay selections: 0 to 10.0s in 0.1 steps (for Definite Time curve selection only)

Disturbance Settings

A disturbance setting can be configured as a percentage of the time overcurrent pickup setting to capture a through-fault record. A disturbance record is captured when the pickup setting has been exceeded because of a through-fault condition through the transformer. The last 32 through-fault records are stored in the unit's nonvolatile memory.

- Pickup: 0.5 to 5 x (51P Pickup setting)

Alarm Settings

The fifteen alarm settings provide alarming functions to the counters shown on the right. Each alarm counter can be disabled or set to alarm at a user selectable threshold. Output contacts can be logically programmed "OR" or "AND" to any alarm counter.

Alarm Thresholds	
Through Faults	Disable
Through Fault Summation kAmp	Disable
Through Fault Summation Cycle	Disable
Overcurrent Trips	Disable
Differential Trips	Disable
Phase Demand	Disable
Neutral Demand	Disable
Load Current	Disable
Demand 3P-kVar	Disable
Low Power Factor	Disable
High Power Factor	Disable
Positive kVar Alarm	Disable
Negative kVar Alarm	Disable
Positive kWatt Alarm 1	Disable
Positive kWatt Alarm 2	Disable
<input type="button" value="Return"/>	

Press Enter

User Interface

You can change settings, monitor metering activities and view operations records through two interfaces: the Man-Machine Interface (MMI) and the External Communications Program (ECP) which is included with the TPU-2000R.

In addition, with the ECP you can logically map inputs and outputs to any associated logic function and you can download Oscillographic Data Storage files and Load Profile data (see "Optional Features").

MMI Change Settings Display

CHANGE PRIMARY SETTINGS
87T Select % Slope
87T Minimum Iop 0.3
87T Percent Slope 20

Metering Display

Ia-1: 100	Ia-2: 600
Ib-1: 100	Ib-2: 600
Ic-1: 100	Ic-2: 600
In-1: 0	Ig-2: 0

Display of Faulted Currents

FAULTED CURRENTS	
Ib-1: 3320	Ib-2: 0
Ic-1: 100	Ic-2: 600
In-1: 100	Ig-2: 0

Man Machine Interface (MMI)

The MMI consists of a four-row by twenty-character backlit LCD and a six-key access panel. During normal operation, the MMI continuously displays four currents for each winding. When a fault occurs, the MMI displays the eight current magnitudes at the time of the fault until the targets are reset. A "FAULTED CURRENTS" message also blinks in the first line of the display, indicating that a fault has occurred. Relay settings, metering, fault and operations records can be accessed directly from the MMI or via the ECP through the front or rear communications ports. For models with voltage inputs, the MMI continuously displays the selected winding currents and voltages. For models without the voltage inputs, the MMI continuously displays the currents of both windings.

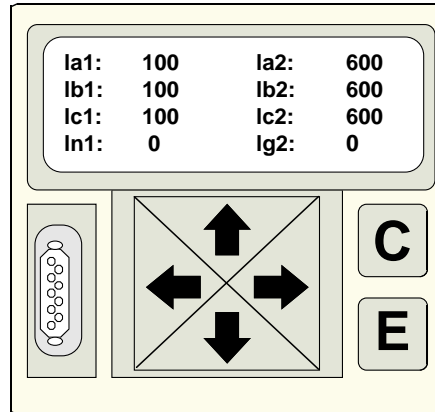

External Communications Program

The External Communications Program (ECP) provides point-to-point communications with the TPU-2000R relay. You can easily program the TPU-2000R's various functions settings via the ECP. The ECP is a DOS®-based program and can be copied to your computer's hard drive. To invoke the program, type "tpeucp."

You also can use the software without the TPU-2000R relay to explore the capabilities and functionality of the relay. When the software is not connected to a TPU-2000R, the settings and configurations displayed are the factory default values. The relay settings can be saved to file and retrieved for downloading to a TPU-2000R later. When the software is connected to a TPU-2000R, the records can be viewed (Get Data From TPU-2000R), saved to a file (Save Data To Disk) and viewed later (Get Data From Disk).

The ECP contains terminal emulation commands to dial through a modem to access the relay or other devices connected to a remote modem.

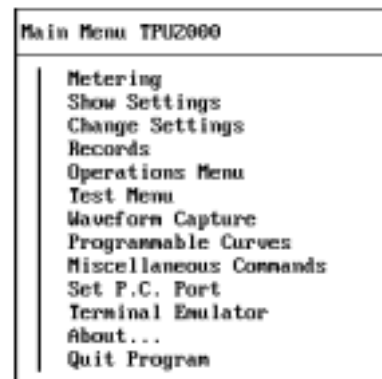

Figure 1. Main Metering Menu of the TPU-2000R ECP

Metering

The Meter Menu of the ECP has the following selectable metered data:

- Load Values
- Demand Values
- Maximum and Minimum Demand Values
- Differential Values

- Per phase kwatts kW-A, kW-B, kW-C, kW-3P
- Zero sequence currents I_0 : amperes and degrees
- Per phase kilowatt hours kWhr-A, kWhr-B, kWhr-C, kWhr-3P
- Per phase KiloVARs kVAR-A, kVAR-B, kVAR-C, kVAR-3P
- Per phase KiloVAR hours kVARhr-A, kVARhr-B, kVARhr-C, kVARhr-3P

Load Values

Winding 1, Winding 2 & Winding 3 (if applicable)

Load metering is represented in per phase or three phase quantities depending on potential transformer configuration; WYE or DELTA. Units without the voltage option will only meter phase and neutral currents.

- Per phase currents **Ia**, **Ib** and **Ic**: amperes and degrees
- Neutral current **In**: amperes and degrees
- Positive and negative sequence currents **I₁** and **I₂**: amperes and degrees
- Per phase voltages **kVan**, **kVbn**, **kVcn**, **kV1**, **kV2** and degrees

Load Values - TPU2000R											
METER MODE: WINDING 2				WINDING 2				WINDING 2			
WINDING 1				WINDING 2				WINDING 2			
IA-1	IB-1	IC-1	IN-1	IA-2	IB-2	IC-2	IN-2	IA-2	IB-2	IC-2	IN-2
AMPS	AMPS	AMPS	AMPS	AMPS	AMPS	AMPS	AMPS	AMPS	AMPS	AMPS	AMPS
DEG	DEG	DEG	DEG	DEG	DEG	DEG	DEG	DEG	DEG	DEG	DEG
505	511	500	2	565	565	561	0	565	565	561	0
324	203	82	68	1	248	128	0	1	106	0	4
359	359	323	68	1	106	0	4	65	65	65	65
11-1	11-1	11-1	11-1	11-2	11-2	11-2	11-2	11-2	11-2	11-2	11-2
505	505	505	505	564	564	564	564	564	564	564	564
7	7	7	7	4	4	4	4	4	4	4	4
60	60	60	60	60	60	60	60	60	60	60	60
WINDING 2	WINDING 2	WINDING 2	WINDING 2	WINDING 2	WINDING 2	WINDING 2	WINDING 2	WINDING 2	WINDING 2	WINDING 2	WINDING 2
kW-A	kW-B	kW-C	kW-3P	kWhr-A	kWhr-B	kWhr-C	kWhr-3P	kVAR-A	kVAR-B	kVAR-C	kVAR-3P
5353	5334	5315	15944	27987	27786	27585	83291	-71	-85	-99	-244
-364	-435	-586	-1253	-364	-435	-586	-1253	-364	-435	-586	-1253
68.81	68.81	68.81	68.81	1.00	1.00	1.00	1.00	1.00	1.00	1.00	1.00
Hz	Hz	Hz	Hz	Leading	Leading	Leading	Leading	Leading	Leading	Leading	Leading

Demand Values

- User configurable to display winding 1, winding 2 or winding 3 demand values which include: per phase and neutral (ground) demand currents, kVARs, kWatts, 3-phase kVARs and 3-phase kWatts.

Demand Values-TPU2000R					
WINDING 2, WYE CONNECT UT					
	AMPS		WATTS		VARs
IA =	565	kW-A =	5369	kVar-A =	-72
IB =	565	kW-B =	5345	kVar-B =	-85
IC =	561	kW-C =	5289	kVar-C =	-89
IG =	0	kW-3P =	16003	kVar-3P =	-246

Hit Enter to Return

Maximum and Minimum Demand Values

- Winding 1, winding 2 or winding 3 phase and neutral (ground) maximum and minimum demand currents with time and date stamp

Max/Min Demand Values - TPU2000R OC IST						
WINDING 2						
	MAX VALUES			MIN VALUES		
	AMPS	DATE	TIME	AMPS	DATE	TIME
IA	565	06/08/95	15:45	555	06/08/95	11:46
IB	565	06/08/95	15:43	553	06/08/95	11:46
IC	565	06/08/95	15:45	553	06/08/95	11:46
IG	22	06/08/95	11:07	2	06/08/95	15:07
kW-A	5369	06/08/95	15:38	5283	06/08/95	13:15
kW-B	5345	06/08/95	15:38	5152	06/08/95	13:15
kW-C	5289	06/08/95	15:38	5184	06/08/95	13:15
kW-3ph	16003	06/08/95	15:38	15459	06/08/95	13:15
kVar-A	-72	06/08/95	15:00	-72	06/08/95	15:45
kVar-B	-82	06/08/95	13:15	-85	06/08/95	15:45
kVar-C	-85	06/08/95	13:15	-89	06/08/95	15:45
kVar-3ph	-238	06/08/95	13:15	-246	06/08/95	15:45

Return

Differential Values

- Operate Currents—Phase A, B and C: magnitude in per unit [vectorial summation of winding 1, 2 and 3 (if applicable) restraint currents]
- Winding 1 Restraint Currents—A-1, B-1 and C-1: magnitude in per unit of 87T-1 tap setting and degrees
- Winding 2 Restraint Currents—A-2, B-2 and C-2; magnitude in per unit of 87T-2 tap setting and degrees
- Winding 3 Restraint Currents—A-3, B-3 and C-3. Magnitude in per unit of 87T-3 tap setting and degrees
- 2nd Harmonic Restraint Currents—A-1, B-1, C-1, A-2, B-2, C-2, A-3, B-3 and C-3 (if applicable) in percent of fundamental current
- 5th Harmonic Restraint Currents—A-1, B-1, C-1, A-2, B-2, C-2, A-3, B-3 and C-3 (if applicable) in percent of fundamental current
- All Harmonics Restraint Currents—A-1, B-1, C-1, A-2, B-2, C-2, A-3, B-3 and C-3 (if applicable) in percent of fundamental current

Differential Metering - TPU2000R OC IST					
PER UNIT					
I Operate A =	0.20	Wdg-1 Tap =	3.00	HARMONICS	
I Operate B =	0.23	Wdg-2 Tap =	6.00	2nd A	0.0%
I Operate C =	0.22			5th A	0.5%
				A11 A	0.5%
				2nd B	0.0%
				5th B	0.5%
				A11 B	0.5%
				2nd C	0.0%
				5th C	0.5%
				A11 C	0.5%

P.U. of TAP WDG-1			ANGLES		
I Restraint A-1=	1.68				
I Restraint B-1=	1.69		239		
I Restraint C-1=	1.65		118		

P.U. of TAP WDG-2			ANGLES		
I Restraint A-2=	1.62		187		
I Restraint B-2=	1.64		66		
I Restraint C-2=	1.62		306		

With correct connections and phase comp. restraint currents will be 180 degrees out of phase.

Return

The differential metering screen allows easy confirmation of correct differential tap settings and relay connections during commissioning

Optional Features

Load Profile

This record stores per-phase currents for winding 1 or winding 2. Time intervals (demand constant) of 5, 15, 30 or 60 minutes can also be selected for which the load profile record will then contain 13.3, 40, 80 or 160 days of information, respectively. The recorded data is stored in a comma delimited ASCII format which allows for importing into most spreadsheet or text editor software for load and data analysis. The adjoining graph, created with a commercially available spreadsheet software, is a sample of the type of load profile data analysis that can be performed.

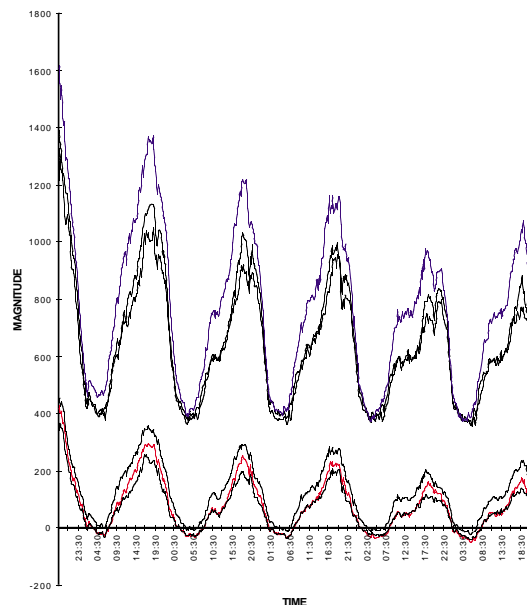
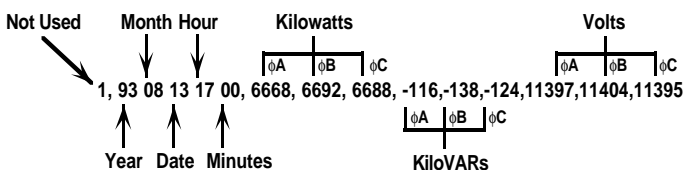

Load Profile Analysis

Oscillographic Display and Analysis Tool

The TPU-2000R can be furnished with oscillographic data storage capability that captures and stores up to 64 cycles of waveform data for each of the eight input currents.

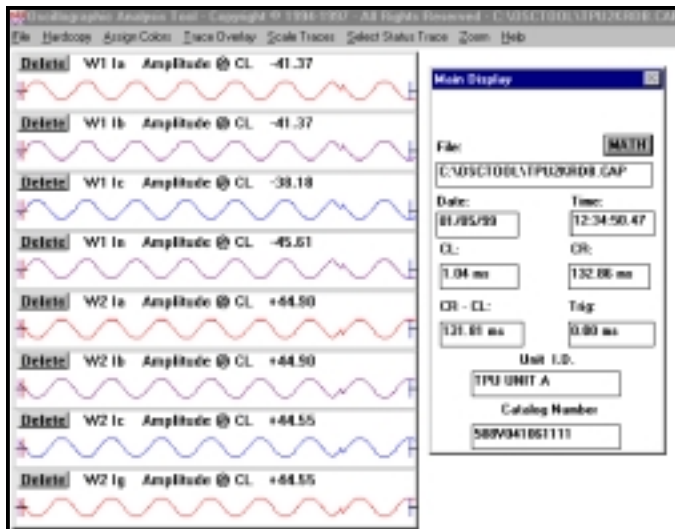

The TPU-2000R can also be programmed to trigger the capturing of waveform data on pickup of the following functions: 87T, 87H, 50N, 50P, 150N, 150P, 50G, 150G-2 and 46. Pre- and post-fault data can be captured by setting the trigger position in quarter-cycle increments within a range of 1 to 32 quarter cycles. Waveform capture can also be activated from an external contact, such as sudden pressure relay.

To the left is an example of a waveform capture displaying the inrush current on energization of the transformer. These waveforms were displayed with the TPU-2000R's PC-based Oscillographic Analysis Tool.

The MATH button located on the Main Display window generates a Fast Fourier Transform of the user-selected phase current. A Spectral Analysis Tool window displays the percent harmonic content for the phase selected for Fourier Transform Analysis; a graphical representation of the Fourier Transform is also generated in the Spectral Analysis Display window.

Eight time-stamped waveform records contain eight cycles of data. Thirty-two points per cycle for each of the eight analog input currents, Winding-1 and Winding-2 for both 2 Winding and 3 Winding units, and numerous protective and logic functions are stored in each waveform record. The capturing of waveform data can be triggered when the trip output is actuated or the waveform capture input (WCI) is initiated.

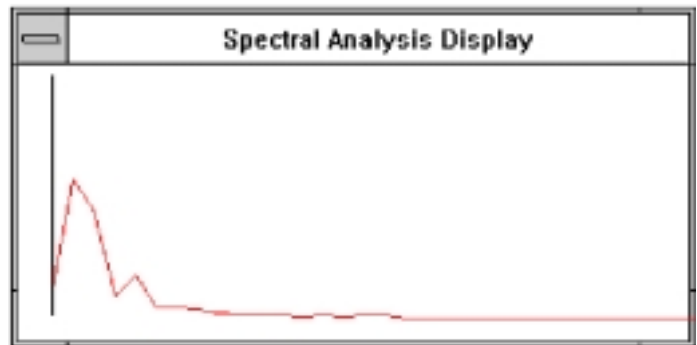

Automatic Tap Settings Calculation

The TPU-2000R has an automated differential tap setting calculation screen. You can automate your tap settings calculation by entering information at the Calculate Tap Settings screen.

The calculated values provided are as follows:

- Tap ratios
- 87T and 87H Tap settings
- Maximum transformer high and low side load currents (IH and IL)
- Maximum transformer high and low side through-fault currents (IHF and ILF)

- Maximum CT secondary currents on high and low side of the transformer (IHS and ILS) for transformer maximum load current
- Maximum CT secondary currents on high and low side of the transformer (IHFA and ILFS) for transformer maximum through-fault current.

Calculate Tap Settings			
Unit Name: TPU2000R	Catalog No: 54800418-6111	Date: 08-Jun-95	
Transformer Rating(MVA):	Self-Cooled: 12.00	Max Force-Cooled: 20.00	
Voltage (kV):	High Side: 115.00	Low Side: 13.80	
Transformer Connect:	High Side: Delta	Low Side: Ygr	
Percent Impedance:	: 8.50%		
Phase Compensation Setting (degrees):	: 30		Calculate
Transformer shift, i.e. the angle by which Wdg1 leads Wdg2.			
Max. Load (IH) =	100.43	Max. Through Fault (IHF) =	200.77
Max. Load (IL) =	836.74	Max. Through Fault (ILF) =	5900.40
Phase CT Ratio	High Side: 20	Low Side: 2000	
	High Side: Wdg-Wdg1	Low Side: Delta-Wdg2	
Max. Load on CT (IHS) =	5.02	Max. Through Fault (IHSF) =	35.44
Max. Load on CT (ILS) =	4.18	Max. Through Fault (ILSF) =	29.53
Apparent Relay Constants	Set 87T-1 Tap to: 5.0		
<IHSF> =	5.02	Set 87T-2 Tap to: 7.3	
<ILSF> =	7.35	Set 87H to: 6.0	
Press F1 for Help			Calculate Returns
Press Enter to Perform Tap Settings Calc			

Operations Summary

The Operations Summary record includes the following counters:

- Number of through-faults
- Through-fault kA summation phase A winding 2
- Number of overcurrent trips
- Through-fault kA summation phase B winding 2
- Number of differential trips
- Through-fault kA summation phase C winding 2
- Through-fault cycle (Duration) summation

Operations Summary - TPU2000R OC TST	
Through Faults	596
Through Fault Summation kAmp A-2	142
Through Fault Summation kAmp B-2	53
Through Fault Summation kAmp C-2	50
Through Fault Cycle Summation	131540
Overcurrent Trips	573
Differential Trips	120
<input type="button" value="Return"/>	

Return to Previous menu

Unreported Records

This record is used for SCADA system relay polling applications. Each new fault or operations record increases that record's counter. This counter flags SCADA during polling to initiate a download of the unreported records. When a record is polled (downloaded) by SCADA or viewed by the user through the Unreported Records menu in the ECP, the associated records counter decreases.

Unreported Records Status						
Differential Records	16					
Through Fault Records	32					
Harmonic Restraint Records	32					
Operation Records	128					
<table border="1"> <tr> <td>View Unrep Differential Recs</td> </tr> <tr> <td>View Unrep Through Fault Recs</td> </tr> <tr> <td>View Unrep Harm Rest Recs</td> </tr> <tr> <td>View Unrep Operation Recs</td> </tr> <tr> <td>Return to Previous Menu</td> </tr> </table>		View Unrep Differential Recs	View Unrep Through Fault Recs	View Unrep Harm Rest Recs	View Unrep Operation Recs	Return to Previous Menu
View Unrep Differential Recs						
View Unrep Through Fault Recs						
View Unrep Harm Rest Recs						
View Unrep Operation Recs						
Return to Previous Menu						
Unreported Differential Records						

Communications Ports

The TPU-2000R is available with both front and rear communications ports. Both ports allow simultaneous local or remote data acquisition and verification and editing of relay settings. The TPU-2000R comes with a standard nine-pin RS-232C serial communications interface located on the front panel. This port is used to interrogate or program the unit via the PC-based External Communications Program (ECP). The ECP software is provided with the unit at no additional charge. ECP uses the 2000R series specific standard protocol, which is an ASCII byte-oriented protocol.

Optional communication port configurations are available on the rear of the TPU-2000R. These ports include:

- RS-232 (9-pin)
- RS-485 (3-wire)
- RS-485 Aux Comm Port
- IRIG-B (for precision time synchronization)
- INCOM™ (2-wire) port
- Modbus Plus™ port

The following optional protocols are available through the rear ports:

- STANDARD – 2000R series specific byte-oriented protocol
- SPACOM—A byte-oriented communications protocol interfacing to SPA-bus
- Modbus®—A byte-oriented communications protocol

- INCOM™—A two-wire, RF carrier-based communications system and protocol
- DNP3.0 (IEC870)—An RS-485-based protocol through the Auxiliary Communications port

Contact your local ABB office for documentation for each of the protocols, or for information about the emulation of other SCADA protocols.

The baud rate for the front and rear ports is as follows:

- FRONT 300, 1200, 2400, 4800 or 9600
- REAR 300, 1200, 2400, 4800, 9600 or 19200

An ABB RS-232 to RS-485 converter (catalog no. 245X2000) can be used to connect a network of TPU-2000Rs to a modem or personal computer. For long runs and high electrical noise environments, fiber-optic communications links are recommended. An ABB RS-485 to fiber-optic converter (catalog no. 245X4000) can be used to network multiple TPU-2000Rs to a central communications center up to 1000 meters away.

See ordering information starting on page 24 for additional information on available port and protocol options.

User-Programmable Curves

An external PC-based program, CurveGen, is used to create and program time-current curves for the TPU-2000R. This is the same program used on the ABB Distribution Protection Unit 2000 (DPU-2000). With CurveGen you can program time-overcurrent curves other than the factory pre-programmed curves in the TPU-2000R. You can manipulate the curves in the time and current domains just like any other curve currently programmed into the TPU-2000R. CurveGen generates all of the necessary variables for the user-defined curves to be stored in the TPU-2000R (i.e. the alpha's, beta's and pointers to the curve table). The method of accomplishing this task is curve definition.

There are multiple methods of generating user defined characteristic curves:

The standard curve entered into the TPU-2000R has the form of:

$$t = \frac{A}{M^{p-C}} + B$$

M is the per-unit current above the pickup value

t is total trip time at *M*.

A, **p**, **C** and **B** are variables to be defined.

To define the curve, you must define the variables in this equation. There are two ways to do this:

- Manual entry of variables: This is designed for users who want to define curves through mathematical manipulation.
- Determine variables via curve fitting: Define a series of time versus current points and fit them to the standard equation listed above.

With the CurveGen program you can enter these series of time/current points from an already defined curve. CurveGen then fits the four variables to these points. There are two ways to enter these points into the CurveGen program:

- Enter all sampled points manually.
- File entry: CurveGen also can read files with points defined in them.

Once all the points are entered, the CurveGen program is cued to fit a standard curve. After *A*, *p*, *C* and *B* have been determined, you can plot the curve against the points given as well as determine the overall error of the curve versus the plotted points.

```

Programmable Curve Menu
Receive Overcurrent Curve Data
Transmit Overcurrent Curve Data
Receive Differential Curve Data
Transmit Differential Curve Data
Return
Receive OC Data from Unit
    
```

Operations Menu

The Operations Menu provides the operator the ability to control physical inputs and outputs, logical inputs or User Logical Outputs (ULO) without the need for a secondary test source injection. This allows the user to control specific physical connections and logical states to the relay through the Man-Machine Interface (MMI).

```

Operations Menu
Trip Breaker
Force Physical Input
Force Physical Output
Seal In/User Alarms
Force Logical Input
Return
Select Forcing State
    
```

Physical Input / Output Status

This contact input/output screen displays the present physical state of all permanently programmed and user-programmed digital input contacts and contact outputs. With this screen you can verify that the logic you programmed for input contacts is responding properly without physically measuring the input voltage status.

```

I/O Contacts
IN 1  ALT1  Open      TRIP      De-Energized
IN 2  ALT2  Open      OUT 1  FRI Trip  Energized
IN 3              Open      OUT 2  SEC Trip Energized
IN 4              Open      OUT 3  DIFF Trp De-Energized
IN 5              Open      OUT 4  Harn Rct De-Energized
IN 6              Open      OUT 5  TRF Fail De-Energized
IN 7              Open      OUT 6  PICKUP  Energized
IN 8              Open
Hit Any Key to Return
    
```

Test Menu

The Test Menu displays options for viewing the physical condition (Energized or De-Energized) and logic state (Open or Closed) of the programmable input and output contacts. This menu is useful in analyzing the programmed logic mapping of the output contacts and contact inputs.

Logical Output Status

Available only on the External Communications Program, the logical output screen shows the present status of the logical outputs, energized or de-energized. Use this screen to verify the proper operation of the relay functions' logic states.

Logical Output Status													
DIFF	0	51G-2	0	50G-2D	0	OTC	0	150P-1*	0	8105	0	W08r0	0
ALARM	1	50N-1	0	150P-1D	0	OCIC	0	150P-2*	0	8106	0	W08r1	0
87T	0	150N-1	0	150P-2D	0	F04	0	150P-3*	0	8107	0	W08r2	0
87H	0	50P-2	0	150G-1D	0	M04	0	51N-1*	0	8108	0		
20R00	0	150G-2	0	150G-2D	0	PR10	1	51G-2*	0	8109	0		
50R00	0	46-1	0	46-1D	0	ALT1	0	50N-1*	0	LOW0	0		
60R00	0	46-2	0	46-2D	0	ALT2	0	150N-1*	0	OC0-1	1		
TCF0	1	87T-2	0	PR10	0	CTC0	0	50G-2*	0	OC0-2	1		
10N	0	50P-3	0	PR00	0	87H*	0	150G-2*	0	8100-1	0		
51P-1	1	51P-1D	0	PC00	0	87N*	0	46-1*	0	8100-2	0		
51P-2	1	51P-2D	0	PR0	1	20R00*	0	46-2*	0	8100-3	0		
50P-1	0	51N-1D	0	61	0	50R00*	0	63*	0	8100-4	0		
150P-1	0	51G-2D	0	10R00	0	60R00*	0	6501	0	8100	0		
50P-2	1	50P-1D	0	TF00	0	51P-1*	0	6502	0	LP00	0		
150P-2	0	50P-2D	0	TF00	0	51P-2*	0	6503	0	Par00	0		
51N-1	0	50N-1D	0	TF00	0	50P-1*	0	6504	0	PR00	0		

1 = Energized, 0 = Not Energized
* = Alarms are sealed in until cleared

Hit Any Key to Return

Output Contacts (Password Protected)

The output contact test mode allows activation of all permanently programmed and user-programmed output contacts via the man-machine interface or the communications port.

Output Contacts

TRIP		<input type="text" value="No"/>
OUT 1	Output 1	No
OUT 2	Output 2	No
OUT 3	Output 3	No
OUT 4	Output 4	No
OUT 5	Output 5	No
OUT 6	Output 6	No

*Press spacebar to toggle Yes/No.

Energize Trip

Logical Input Status

Available only on the External Communications Program, the logical input screen shows the present status of the logical inputs.

Logical Input Status					
87T	1	ALT1	0	ULI9	0
87H	1	ALT2	0	CRI	0
51P-1	1	ECI1	0		
51P-2	1	ECI2	0		
51N-1	1	WCI	0		
51G-2	1	TRIP	0		
50P-1	1	SPR	0		
50P-2	1	TCM	1		
50N-1	1	ULI1	0		
50G-2	1	ULI2	0		
150P-1	1	ULI3	0		
150P-2	1	ULI4	0		
150N-1	1	ULI5	0		
150G-2	1	ULI6	0		
46-1	1	ULI7	0		
46-2	1	ULI8	0		

1 = Enabled/Asserted, 0 = Disabled/Not Asserted

Hit Any Key to Return

Diagnostics

The TPU-2000R provides continuous self-testing of its power supply voltages, memory elements, digital signal processor and program execution. In the event of a system failure, the protective functions are disabled and the self-check alarm contacts are actuated. Self-Test Failures are recorded in the Operations Record.

Programmable Output Contacts

Six (6) user-programmable output contacts allow for logic OR or AND programming of any combination of functions to any user selectable output contact. Each contact may be assigned a time delay of 0 to 60 seconds in 10 millisecond increments.

The following list is a sample of some of the functions that the six user-programmable output contacts can be programmed to indicate:

- | | | | |
|--------------|---|-------------|--|
| • Diff | 87T & 87H Differential Trip Alarm | • PATA | Phase A Target LED Alarm |
| • Alarm | Self Check Alarm | • PBTA | Phase B Target LED Alarm |
| • 2HROA | 2nd Harmonic Restraint Alarm | • PCTA | Phase C Target LED Alarm |
| • 5HROA | 5th Harmonic Restraint Alarm | • PUA | Pickup Alarm |
| • AHROA | All Harmonics Restraint Alarm | • 63 | Sudden Pressure Output Alarm |
| • TCFA | Trip Circuit Failure Alarm | • THRUFA | Through-fault Alarm |
| • TFA | Trip Failure Alarm | • TFCA | Through-fault Counter Alarm |
| • 87T | Percentage Differential Trip | • TFKA | Through-fault kAmp Sum Alarm |
| • 87H | High Set Inst. Differential Trip | • TFSCA | Through-fault Cycle Sum Alarm |
| • 51P-1, -2 | 1st Phase Time OC Trip, winding 1 or winding 2 | • DTC | Differential Trip Counter Alarm |
| • 51N-1 | Wdg1 Neutral Time OC Trip | • OCTC | Overcurrent Trip Counter Alarm |
| • 51G-2 | Wdg2 Ground Time OC Trip | • PDA | Phase Current Demand Alarm |
| • 50P-1, -2 | 1st Phase Inst. OC Trip, winding 1 or winding 2 | • NDA | Neutral Current Demand Alarm |
| • 50N-1 | 1st Wdg1 Neutral Inst. OC Trip | • PRIM | Primary Set Enabled Alarm |
| • 50G-2 | 1st Wdg2 Ground Inst. OC Trip | • STCA | Settings Table Changed Alarm |
| • 150P-1, -2 | 2nd Phase Inst. OC Trip, winding 1 or winding 2 | • OCA-1,-2 | Overcurrent Alarm, winding 1 or winding 2 |
| • 150N-1 | 2nd Wdg1 Neutral Inst OC Trip | • HLDA-1,-2 | High Level Detection Alarm, winding 1 or winding 2 |
| • 150G-2 | 2nd Wdg2 Grnd Inst OC Trip | • LPFA | Low Power Factor Alarm |
| • 46-1, -2 | Neg Seq Time OC Trip, winding 1 or winding 2 | • HPFA | High Power Factor Alarm |
| | | • LLDA-1,-2 | Low Level Detection Alarm, winding 1 or winding 2 |

Change Programmable Outputs - TPU2000R						
TIMERS:	0.00	0.00	0.00	0.00	0.00	0.00
NAME:	OUT-1	OUT-2	OUT-3	OUT-4	OUT-5	OUT-6
	PRI Trip	SEC Trip	DIFF Trp	Harm Rst	TRP Fail	PICKUP
LOGIC	OR	OR	OR	OR	OR	OR
DIFF			X			
ALARM						
IFA					X	
87T						
87H						
2HROA				X		
5HROA						
AHROA						
51P-1	X					
51P-2		X				
50P-1	X					
150P-1	X					
50P-2		X				
150P-2		X				

X = Output is selected. LOGIC can be AND or OR. Use UP, DOWN, LEFT, RIGHT arrows, and ENTER. Use F1 to edit Timer fields. ESC to Exit screen. Press Spacebar for Selections

Programmable Binary (Contact) Inputs

The TPU-2000R also provides eight user-programmable contact inputs that are user-configurable in an AND or OR logic configuration map. The following are a few samples of the protective functions and/or events that can be mapped.

- 51P-1, -2 1st (Wdg 1 or Wdg2) Phase Time OC Enable
- 87T Percent Differential Enable
- 87H High Set Inst. Differential Enable
- 50P-1, -2 1st (Wdg1 & Wdg2) Phase Inst. OC Enable
- 51N-1 Wdg1 Neutral Time OC Enable
- 51G-2 Wdg2 Ground Time OC Enable
- 150P-1, -2 2nd (Wdg1 & Wdg2) Phase Inst. OC Enable
- 50N-1 1st Wdg 1 Neutral Inst OC Enable
- 50G-1 1st Wdg 2 Ground Inst OC Enable
- 150N-1 2nd Wdg1 Neutral Inst OC Enable
- 150G-2 2nd Wdg1 Grnd Inst OC Enable
- 46-1, -2 Wdg1 or Wdg2 Neg Seq Time OC Enable
- ALT1, ALT2 Table Settings Enable for ALT1 or ALT2
- ECI 1 & 2 Enables Event 1 or 2 Capture initiated
- WCI Waveform Capture Initiated
- TRIP Initiate Differential Trip Output
- SPR Sudden Pressure Input
- TCM Trip Coil Monitoring Input

Change Programmable Inputs - TPU2000R OC TST								
NAME:	ALT1	ALT2	IN-3	IN-4	IN-5	IN-6	IN-7	IN-8
LGC	IN-1	IN-2						
87T	AND	C						
87H	AND	C						
51P-1	AND							
51P-2	AND							
51N-1	AND		C					
51G-2	AND		C					
50P-1	AND							
50P-2	AND							
50N-1	AND							
50G-2	AND							
150P-1	AND							
150P-2	AND							
150N-1	AND							
150G-2	AND							
46-1	AND					C		
46-2	AND					C		

C = Enable-closed, Disable-opened; 0 = Enable-opened, Disable-closed
 Use UP, DOWN, LEFT, RIGHT arrows, and ENTER. Logic can be AND or OR.
 Press F1 to edit Input Names. Press ESC to go to Save Screen.
 Press Spacebar for Selections

Ratings And Tolerances

Current Input Circuits

- 5-A input rating, 16 A continuous and 450 A for 1 second
- 1-A input rating, 3 A continuous and 100 A for 1 second
- Input burden at 0.245 VA at 5 A (1-12A range)
- Input burden at 0.014 VA at 1 A (0.2-2.4A range)
- Frequency 50 or 60 Hz

Voltage Input Circuit

Voltage ratings based on the VT connection setting.

BURDEN

- 0.04 VA for V(A-N) at 120 Vac

VOLTAGE

- **Wye** Connection: 160 V continuous
- **Delta** Connection: 260 V continuous

Contact Input Circuits Voltage Range

- 19 to 280 Vdc

Contact Input Circuits (Input Burden)

- 2.10 VA at 220 Vdc and 250 Vdc
- 0.52 VA at 125 Vdc and 110 Vdc
- 0.08 VA at 48 Vdc
- 0.02 VA at 24 Vdc

Control Power Requirements

- 48 Vdc model, range = 38 to 58 Vdc
- 110/125/220/250 Vdc models, range = 70 to 280 Vdc
- 24 Vdc model, range = 19 to 29 Vdc

Sampling Rate

- 32 Samples per cycle for all functions including protection, metering and oscillography

Operating Temperature

- -40° to +70° C—*Operating temperatures below -20° C may impede the LCD contrast.*

Humidity

- Per ANSI 37.90, up to 95% without condensation

Output Contacts Ratings

125 Vdc

- 30 A tripping
- 6 A continuous
- 0.25 A break inductive

220/250 Vdc

- 30 A tripping
- 6 A continuous
- 0.1 A break inductive

Transient Immunity

- Surge withstand capability
 - SWC and fast transient tests per ANSI C37.90.1 and IEC 255-22-1 class III and 255-22-4 class IV for all connections except comm or AUX ports
 - Isolated comm ports and AUX ports per ANSI 37.90.1 using oscillatory SWC Test Wave only and per IEC 255-22-1 class III and 255-22-4 class III
 - Impulse voltage withstand test per IEC 255-5
 - EMI test per ANSI C37.90.2

Dielectric

- 3150 Vdc for 1 second, all circuits to ground except comm ports
- 2333 Vdc for 1 second, for isolated communication ports

Weight (Standard 2000R unit)

- Unboxed 5.4 kg (11.9 lbs) (weight may vary by approx. 1Kg (2lbs.) depending on unit configuration)
- Boxed 5.7 kg (12.5 lbs)

Figure 2a. Variable % Differential (HU) Characteristic

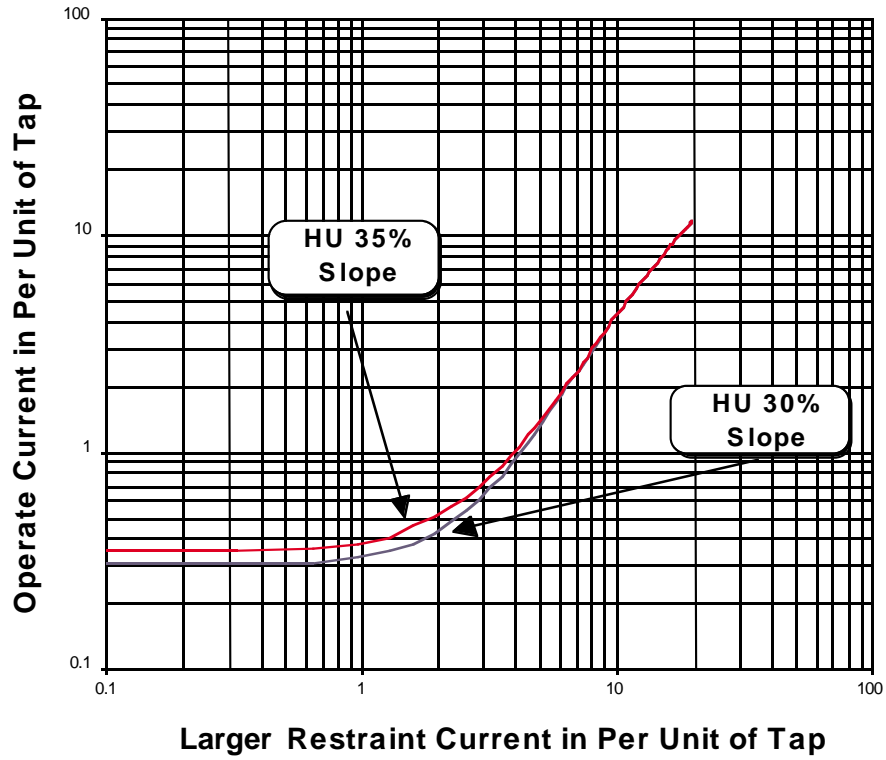

Figure 2b. Constant % Differential Characteristic

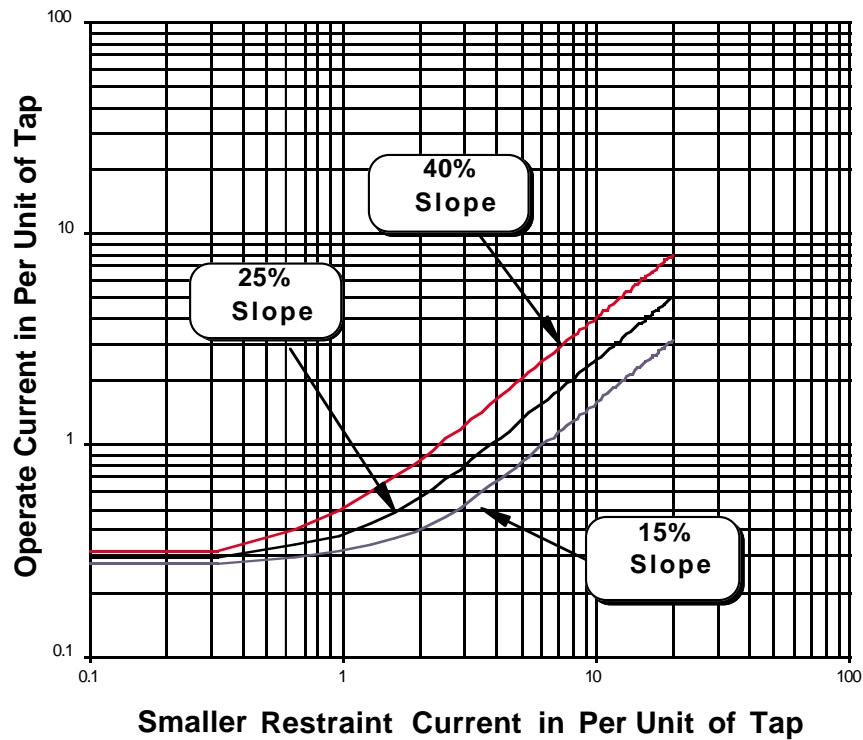
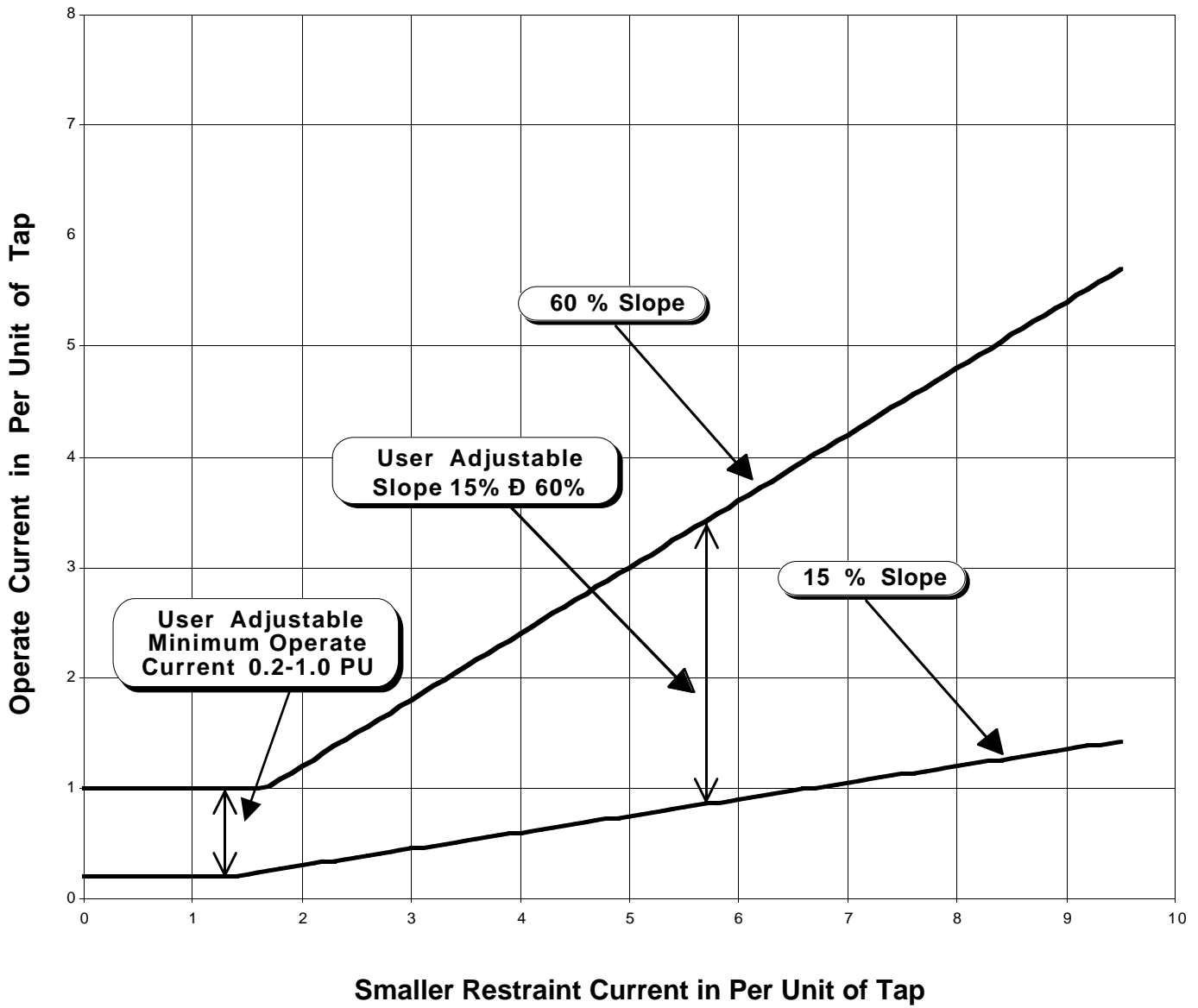

Figure 2c. Adjustable Constant % Differential Characteristic



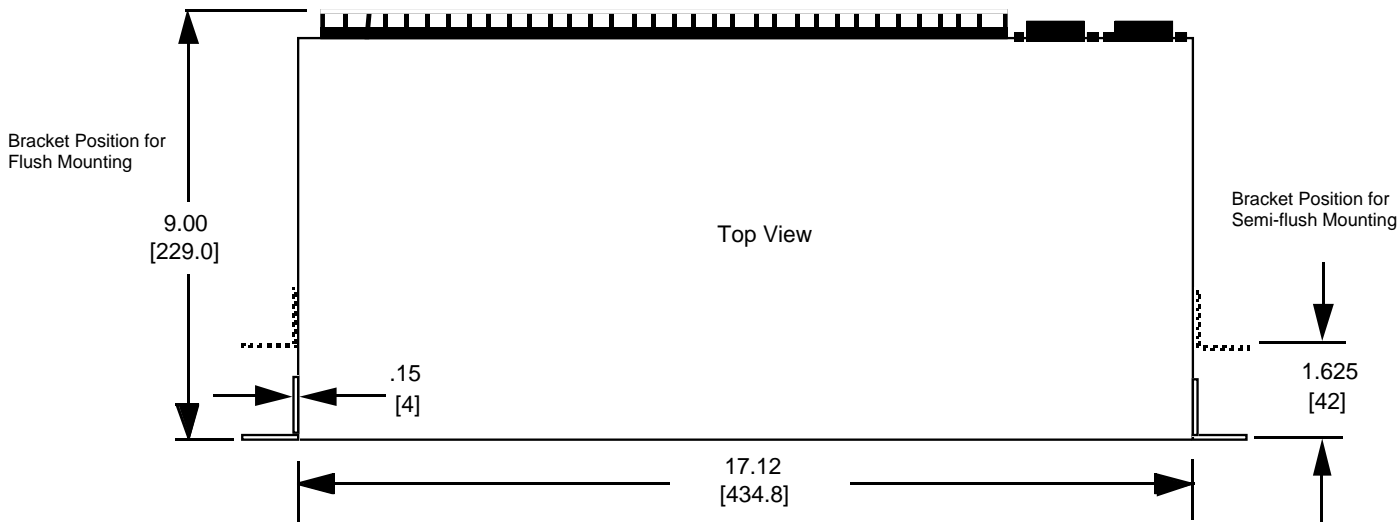
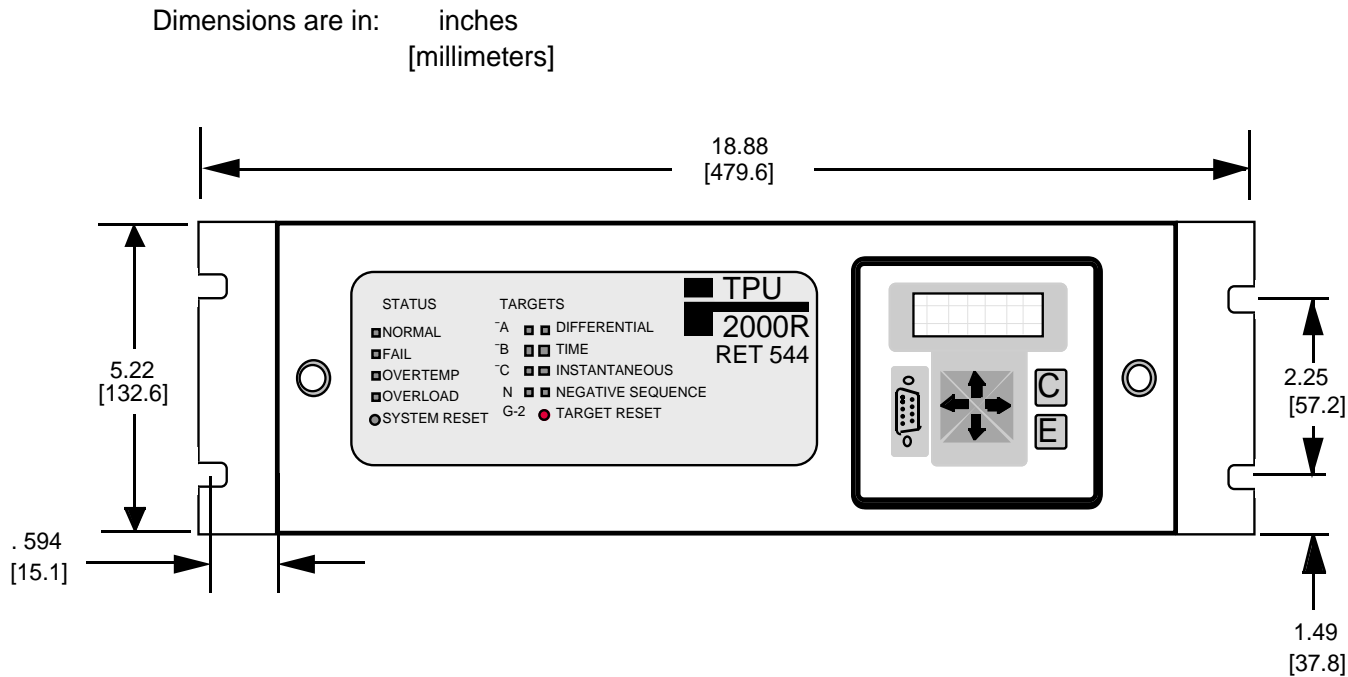

Figure 3. Case Dimensions
2 Winding and 3 Winding Models

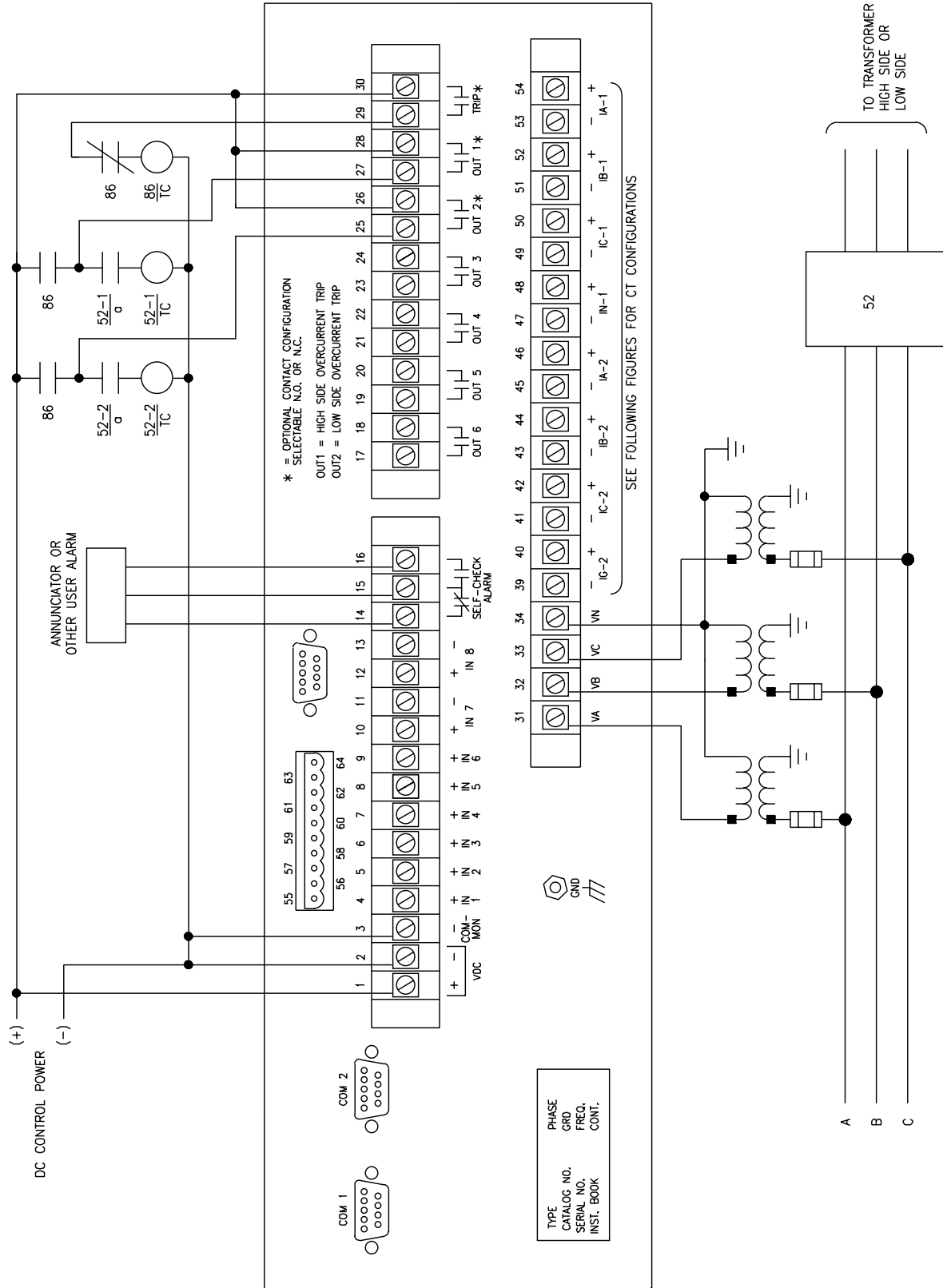

Figure 4. Rear Terminal Connection
Typical PT and Control Connections – TPU-2000R – 2 Winding Model
 (Refer to Figures 9, 10, 11 and Instruction Book for 3 Winding Model)

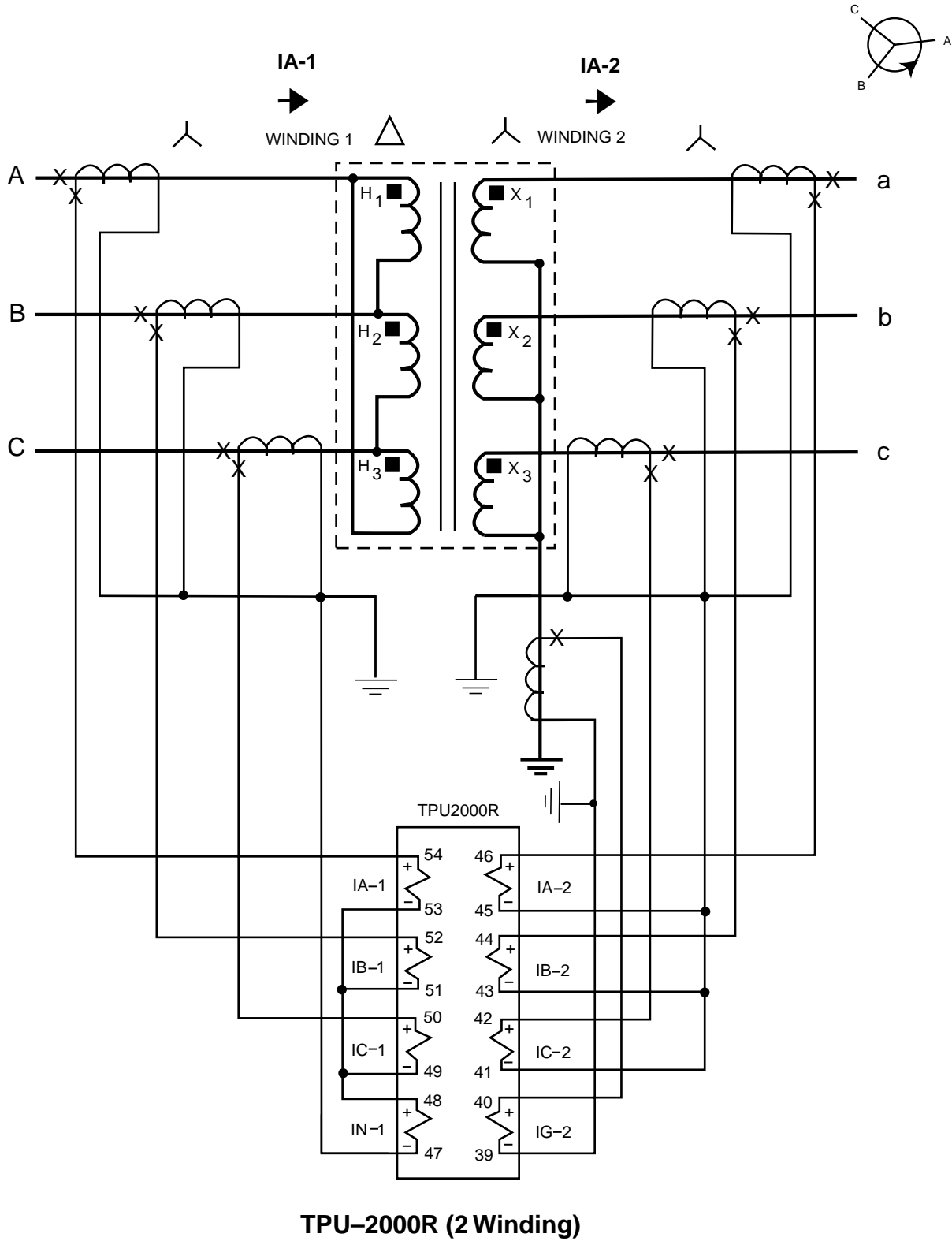
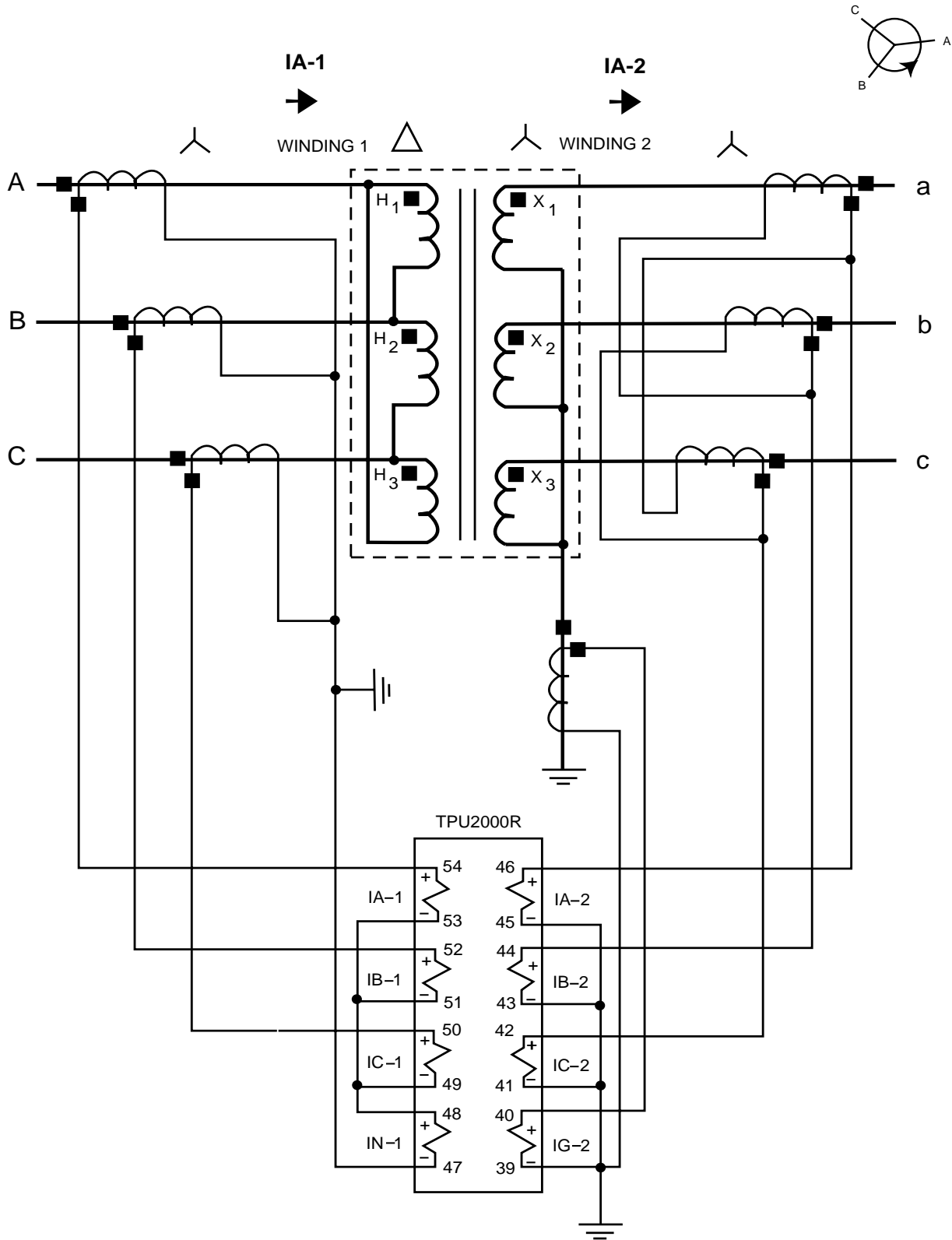
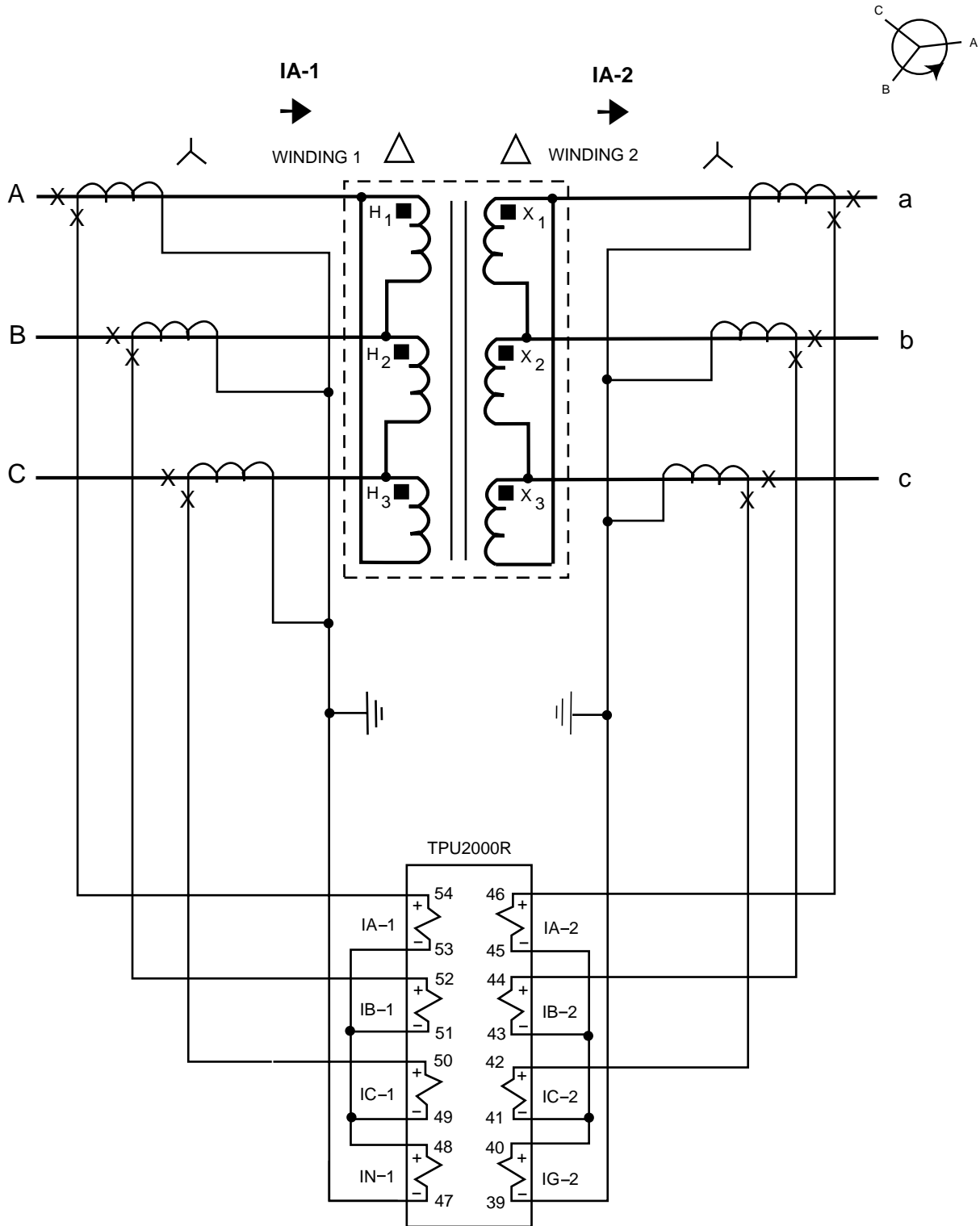

Figure 5. Delta 1 - Wye 2 Power Transformer and Wye-Wye Current Transformer Configuration



TPU-2000R (2 Winding)

Figure 6. Delta 1 - Wye 2 Power Transformer and Wye-Delta Current Transformer Configuration



TPU-2000R (2 Winding)

Figure 7. Delta 1 - Delta 2 Power Transformer and Wye-Wye Current Transformer Configuration

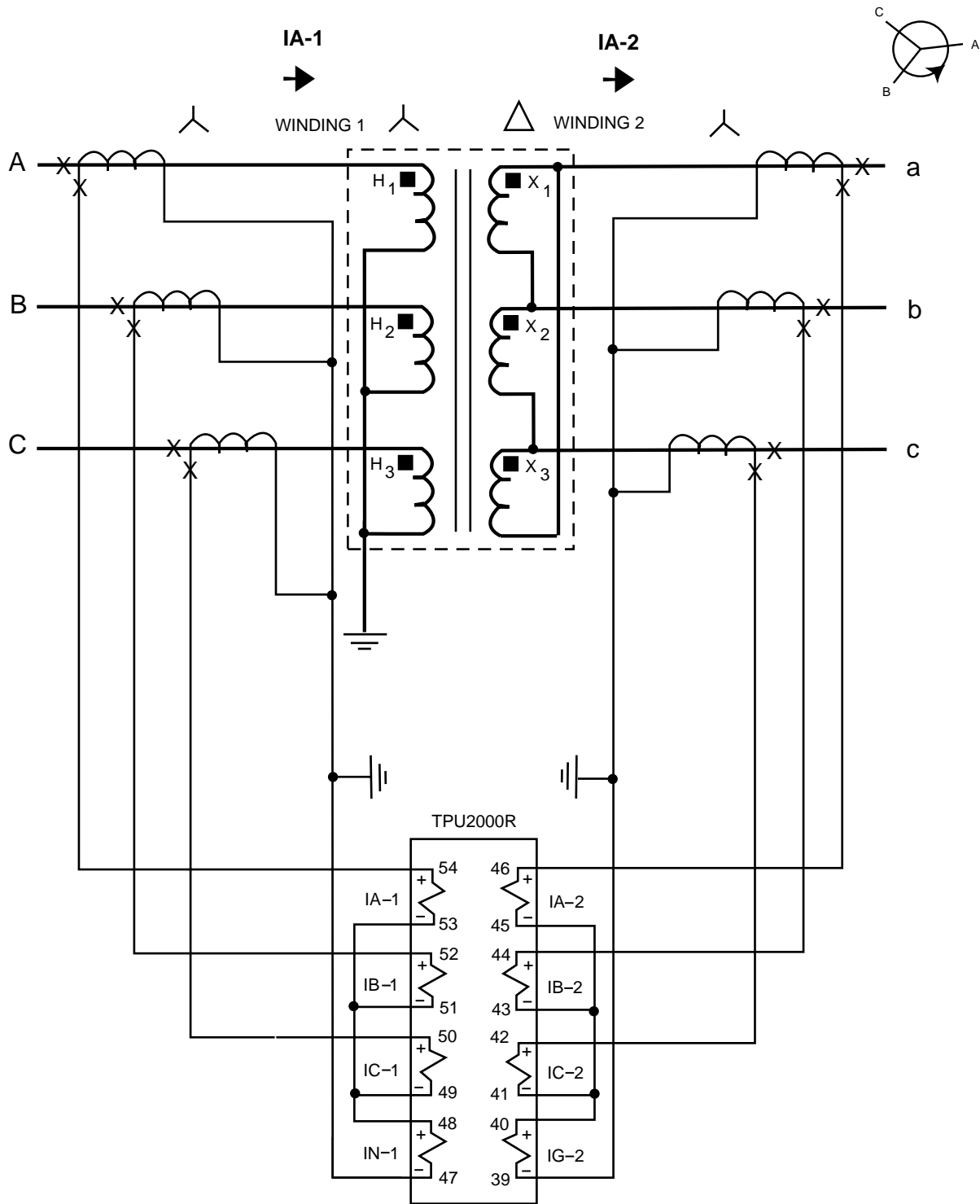

TPU-2000R (2 Winding)

Figure 8. Wye 1 - Delta 2 Power Transformer and Wye-Wye Current Transformer Configuration

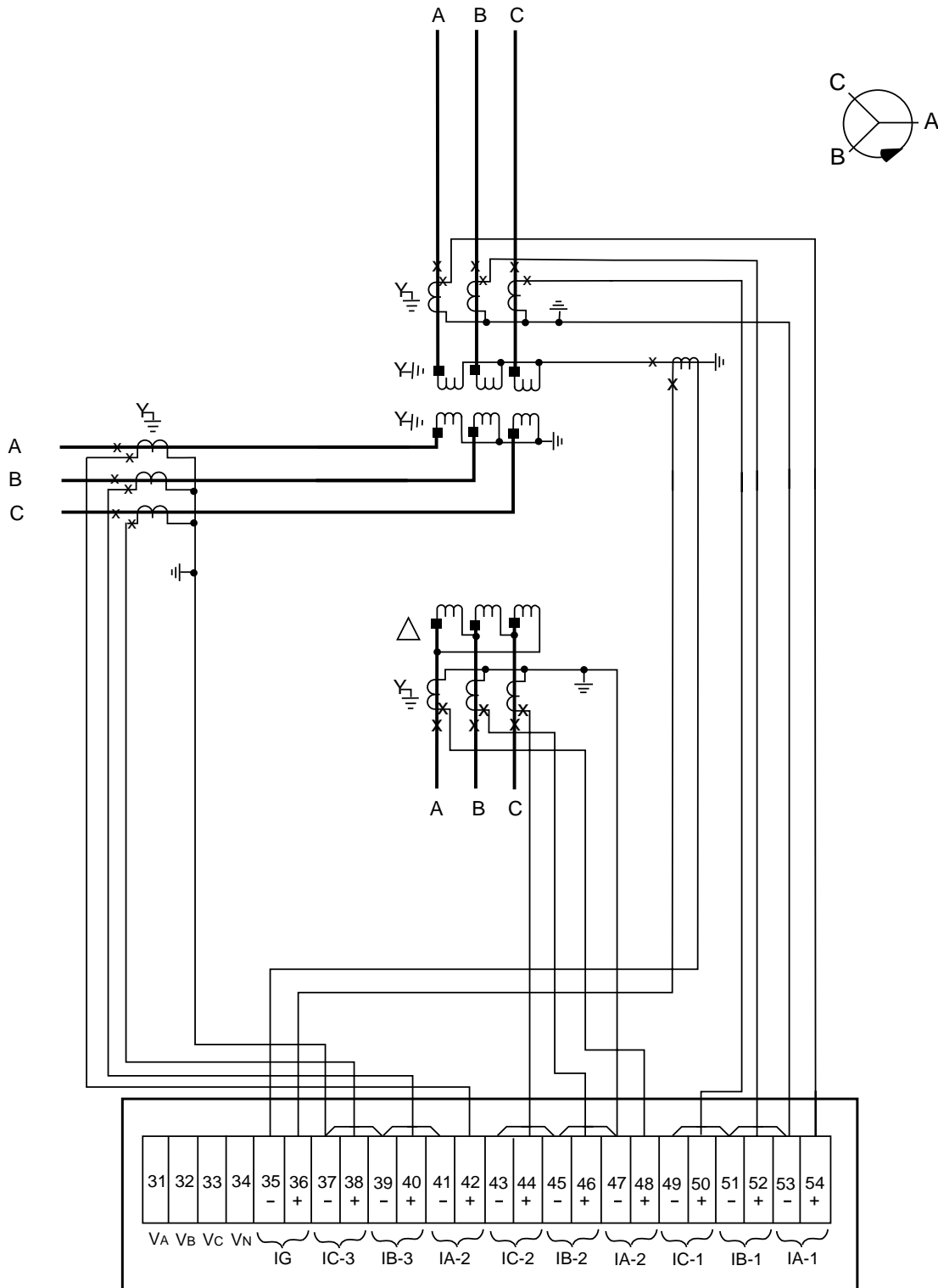

TPU - 2000R (3 Winding)

Figure 9. Wye 1 - Delta 2 - Wye 3 Transformer Configuration

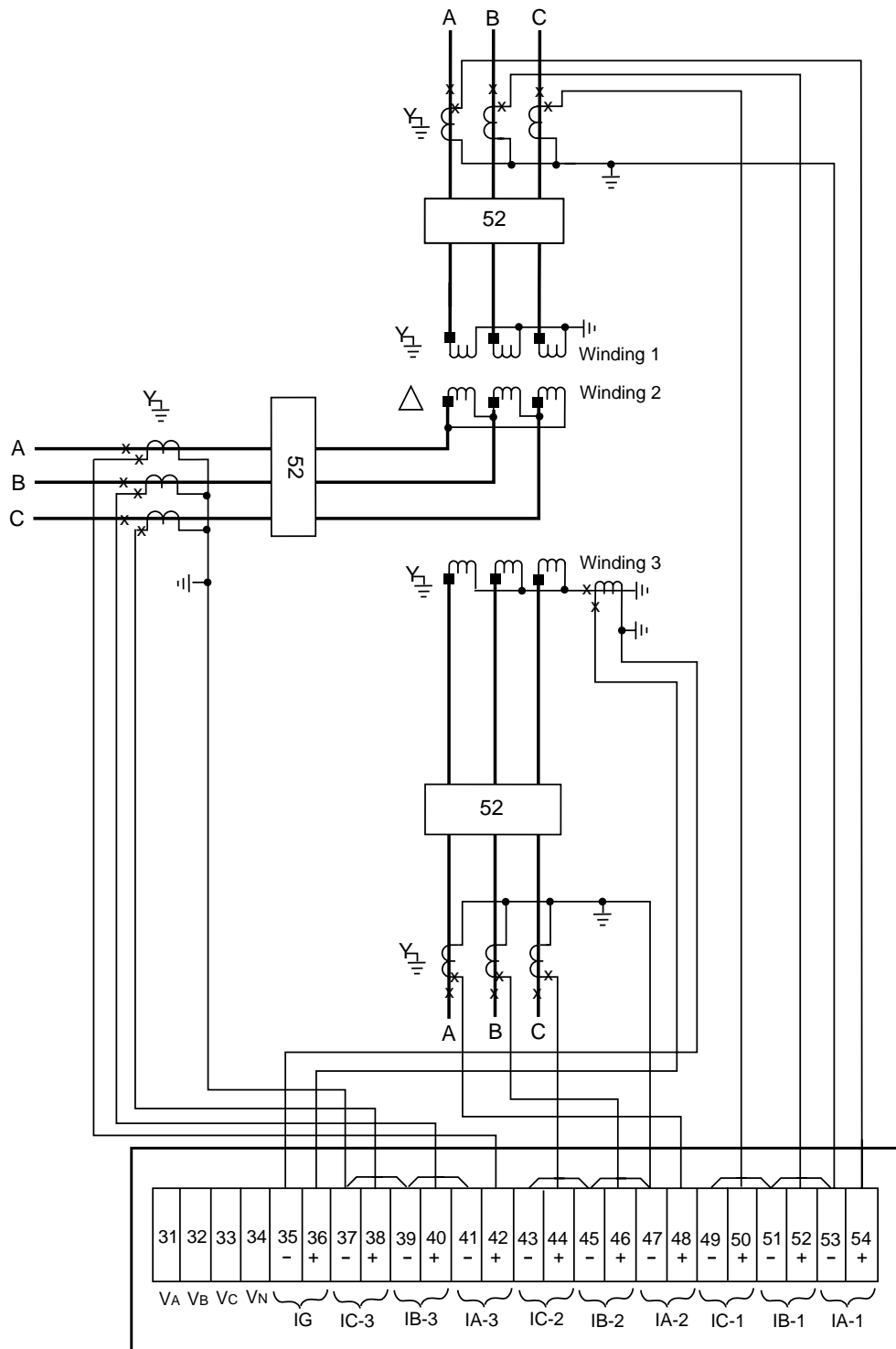
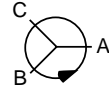

TPU 2000R (3 Winding)

Figure 10. Wye1 - Wye 2 - Delta 3 Transformer Configuration

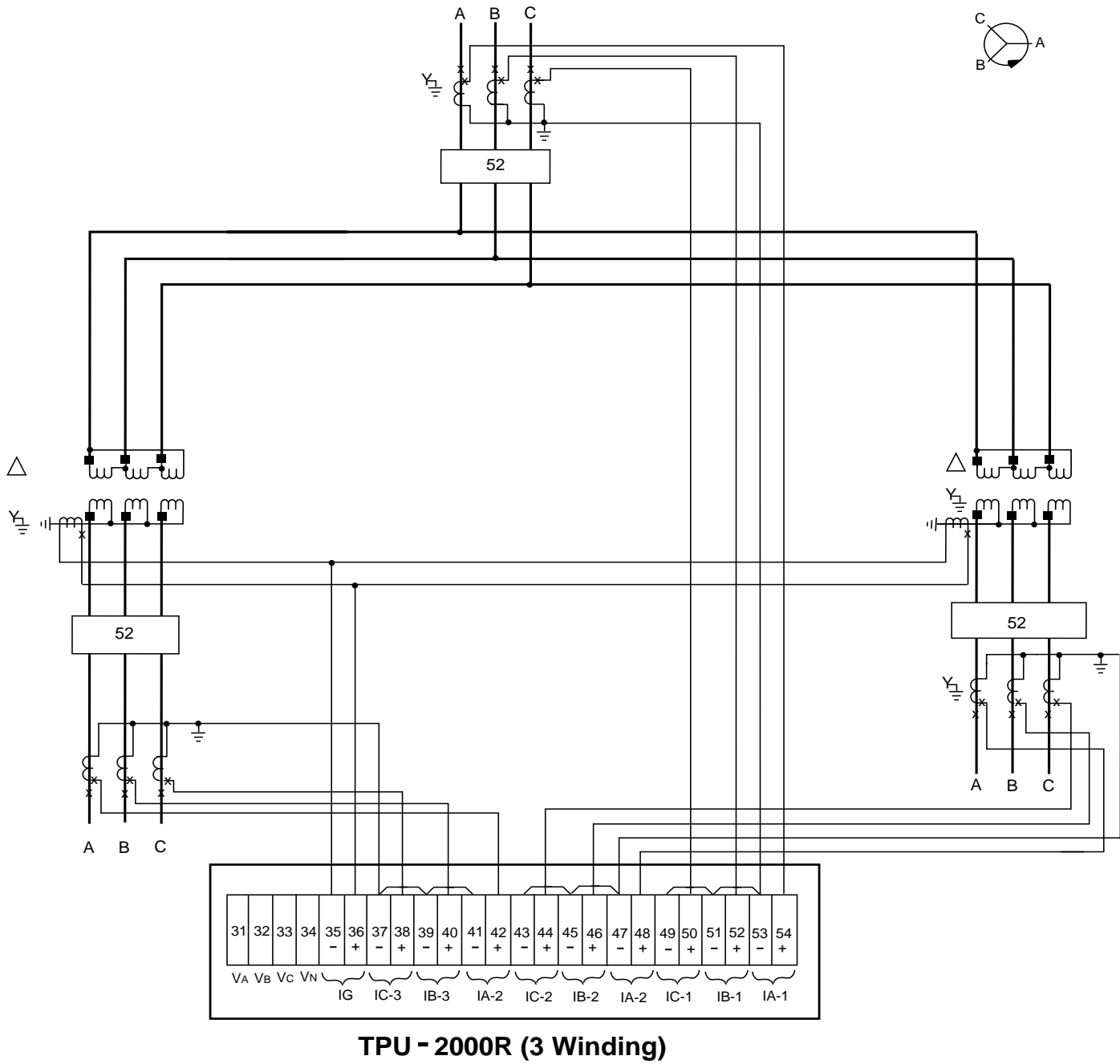
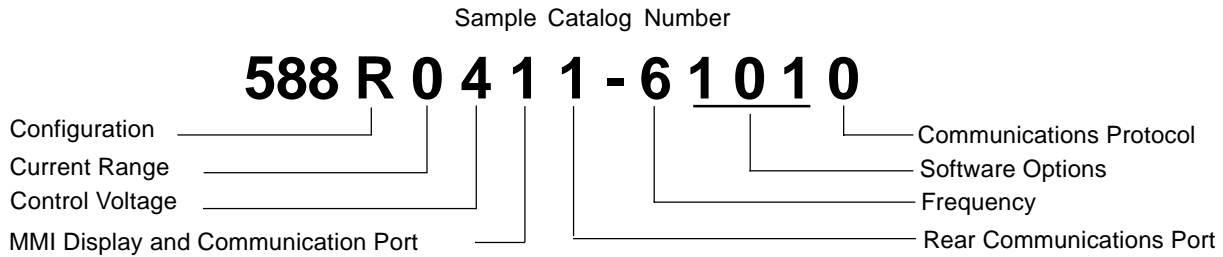

Figure 11. Delta 1 - Wye 2 - Wye 3 Transformer Configuration: Parallel Two Winding Transformers with Common High Side Breaker

Ordering Instructions

The 2000R series of relays have a structured catalog number ordering system. The unit's catalog number is built up from 13 customer-selectable characters. Each character identifies features or functions that can be incorporated into the relay.



How To Order

Using the Ordering Selection sheet, select those special features or options that are required to adapt the 2000R to your specific application. Create the catalog number, as shown above, by selecting the associated number or letter that refers to the desired feature or option from each category.

Communication Port Configurations

The 2000R platform provides several variations of communication ports, such as a 9-pin RS-232, RS-485, INCOM™ and Modbus Plus™. Also available is a list of factory supported common communication protocols for networking the unit.

RS-232 ports are available in two different configurations, Isolated and Non-Isolated. Isolated ports provide isolation between the communication port and the rest of the relay.

COM 1 port is configured as a non-isolated port only. Units having an MMI display use the RS-232 port on the front panel as COM 1, thereby permanently disabling the RS-232 port marked COM 1 on the rear of the unit. Units not having an MMI Display permit the user to select, via jumper setting, either the front or rear (labeled COM 1) RS-232 connectors to act as COM 1.

COM 2 port is a non-isolated configuration and COM 3 port is an isolated configuration. Refer to the following list of options to select the most suitable configuration.

The 2000R series also features ABB's innovative RS-485 isolated communications capability available when the optional Auxiliary Communication board is installed. This isolated RS-485 configuration provides superior communication quality recommended for applications in areas of high electrical noise or that require connecting cables longer than 10 feet (3m).

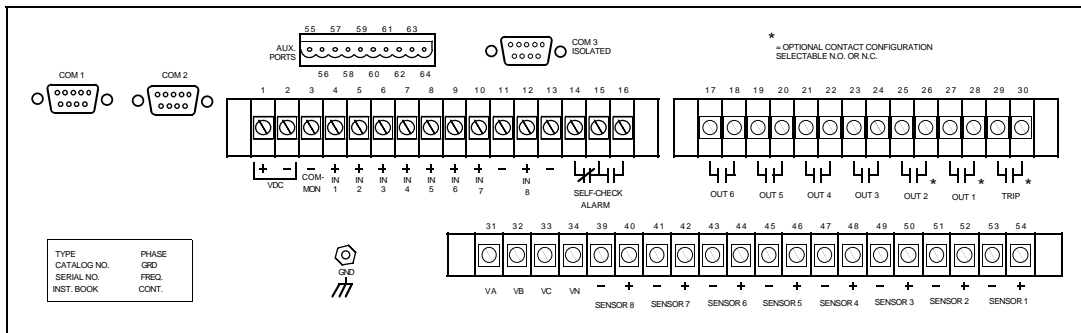

**Rear Terminal Blocks (2 Winding Unit) and Communication Ports
 (Refer to Figures 9, 10, 11 and Instruction Book for 3 Winding Model)**

NOTE: Non-isolated RS-232 ports are susceptible to electrical noise. For that reason it is recommended that connecting cables be no longer than 10 feet (3m) when connecting to a non-isolated port. Devices connected to non-isolated ports must have the same ground return as the 2000R unit.

Refer to the Select Communication Options Table when making option selections.

In addition to the standard front or rear non-isolated RS-232 port (COM 1), the following rear communication port options are available:

Option 0

This option provides RS-232 communication via the non-isolated COM 2 port and is suitable only in applications where communication to the unit is local through a direct connection to a PC or remote through an external isolating communication device, such as an RS-232 to fiber optic converter, which is connected to the relay using a short cable.

Options 1 through 8 are provided on an independent communication card installed in the unit.

Option 1

This option provides RS-232 communication via the isolated COM 3 port for transient immunity and isolation and must be used where communication cable lengths are greater than 10 feet (3m) or a common ground is not guaranteed. In general, RS-232 communication is limited to a maximum distance of 50 feet (15m). Aux Com and COM 2 ports are disabled in this configuration.

Option 2

This option provides RS-232 communication via isolated COM 3 port and RS-485 communication via the isolated Aux Com ports. The auxiliary port is an isolated RS-485 configuration that supports several communication protocols (See *Communication Protocol Category On Ordering Sheet*).

Option 3

This option provides INCOM™ availability, via the Aux Com port, in applications where either the Westinghouse INCOM™, or ABB WRELCOM™, network is used.

Option 4

This option provides RS-485 communication and INCOM™ availability, via the isolated Aux Com port. In this configuration, the INCOM™ port provides the same functionality as option 3.

Option 5

This option provides RS-485 communication via the isolated Aux Com port and is highly recommended for applications requiring communication over distances of up to 300 feet (100m). This option has an advantage over RS-232 by allowing networking of multiple relays via a simple 3 wire connection.

An RS-485 to RS-232 converter (Catalog Number 245X2000) is available to connect the network to an external device such as a modem or a personal computer.

Option 6

This option provides a Modbus Plus™ interface, via the COM 3 port, and RS-232 communication via the non-isolated COM 2 port.

Option 7

This option provides a Modbus Plus™ interface via the COM 3 and RS-485 communication via the isolated Aux Com port.

Option 8

This option provides RS-485 communication via the isolated COM 3 and Aux Com ports.

Communication Protocols

The Select Options Table shows the communication protocols and the respective hardware port assignments that are currently available.

The "Standard" Protocol

The "Standard" protocol referenced throughout this publication refers to an ABB 2000 series-specific 10 byte ASCII oriented communication protocol. This protocol is standard for COM 1 and is selectable for other rear ports as per the Select Options Table. The 2000 series External Communication Program (ECP) provided, at no charge, with the relay uses the standard protocol.

Product specific protocol documents are available from the factory upon request.

Software Options

The software options available on the 2000R series include Load Profile, User Programmable Curves, and Oscillographic Data. Any combination of these options may be selected.

3 character locations in the catalog number define your selection of software options.

- Oscillographics
- User Programmable Curves
- Load Profile

The table below illustrates all possible hardware configurations for the communication ports and the supported protocols. The Catalog Number Select Option columns list every communication option for which the relays can be configured.

The different protocol variations are outlined under the corresponding communication ports that support them. Select the row containing the protocol combination that best suits your communications requirements and use the corresponding catalog number options to fill in the brackets [] of the catalog number.

The auxiliary port labelled IRIG-B receives a demodulated IRIG-B signal for 2000R clock synchronization purposes.

For example, if your system requires DNP 3.0 (IEC870-5) protocol, the ordering catalog number would be 588R041[2]-6101[1] (4th row), 588R041[4]-6101[1](10th row) or 588R041[8]-6101[1](18th row) based on your choice for the second port provided.

Select other characteristics of the relay from the chart on page 28.

**Catalog Number
Select Option**

↓ ↓

REAR PORT ASSIGNMENTS

COM 1: NON ISOLATED RS-232
COM 2: NON ISOLATED RS-232
COM 3: ISOLATED RS-232 unless noted
ALIX. PORTS: RS-485 ISOLATED
INCOM: ISOLATED
IRIG-B

588R041[] - 6101[]		With Display	Without Display*						
0	0		Standard	Standard					
1	0		Standard		Standard				
2	0		Standard		Standard	Standard			IRIG-B
2	1		Standard		Standard	DNP 3.0			
2	2		Standard		Standard	Standard			
2	4		Standard		Modbus® or Standard See Note #	Modbus® or Standard See Note #			IRIG-B
3	0		Standard				INCOM		IRIG-B
4	0		Standard			Standard	INCOM		IRIG-B
4	1		Standard			DNP 3.0	INCOM		
4	2		Standard			SPACOM	INCOM		
4	4		Standard			Modbus®	INCOM		IRIG-B
5	0		Standard			Standard			
6	4		Standard	Standard	Modbus® (Modbus Plus™)				
7	4		Standard		Modbus® (Modbus Plus™)	Standard			
8	0		Standard		Standard (RS-485)	Standard			
8	2		Standard		SPACOM (RS-485)	SPACOM			
8	4		Standard		Modbus® or Standard (RS-485) See Note #	Modbus® or Standard See Note #			

Select Communication Options Table

An empty selection box indicates communication port is either not provided or is disabled.

Consult factory for availability.

* Main board jumper selectable front or rear.
Protocol selectable in settings process, all 4 combinations possible.

Current Range Options

Current Range				Catalog Digit Selection 			
Winding 1 Phase Ground		Winding 2 Phase Ground		Winding 3 Phase Gound		Ground	No.
1 - 12	1 - 12	1 - 12	1 - 12	—	—	—	0
1 - 12	.2 - 2.4	1 - 12	.2 - 2.4	—	—	—	1
.2 - 2.4	.2 - 2.4	.2 - 2.4	.2 ÷ 2.4	—	—	—	2
1 - 12	1 - 12	.2 - 2.4	.2 - 2.4	—	—	—	3
.2 - 2.4	.2 - 2.4	1 - 12	1 - 12	—	—	—	4
.02 - .24	.02 - .24	1 - 12	1 - 12	—	—	—	5
.02 - .24	.02 - .24	1 - 12	.2 - 2.4	—	—	—	6
.02 - .24	.02 - .24	.2 - 2.4	.2 - 2.4	—	—	—	7
1 - 12	1 - 12	.02 - .24	.02 - .24	—	—	—	8
1 - 12	.2 - 2.4	.02 - .24	.02 - .24	—	—	—	9
.2 - .24	.2 - 2.4	.02 - .24	.02 - .24	—	—	—	A
.02 - .24	.02 - .24	.02 - .24	.02 - .24	—	—	—	B
1 - 12	—	1 - 12	—	1 - 12	—	1 - 12	C
1 - 12	—	1 - 12	—	.2 - 2.4	—	1 - 12	D
1 - 12	—	.2 - 2.4	—	.2 - 2.4	—	1 - 12	E
.2 - 2.4	—	.2 - 2.4	—	.2 - 2.4	—	1 - 12	F
1 - 12	—	1 - 12	—	1 - 12	—	.2 - 2.4	G
1 - 12	—	1 - 12	—	.2 - 2.4	—	.2 - 2.4	H
1 - 12	—	.2 - .24	—	.2 - 2.4	—	.2 - 2.4	J
.2 - 2.4	—	.2 - 2.4	—	.2 - 2.4	—	.2 - 2.4	K

Note: .02 – .24 range is for use with ABB Optical CT's.

Panel Mounting Kit:

The complete kit will include a bezel, its associated hardware and gasket, as well as a lens cover with its associated hardware. This kit will provide a means for panel mounting and dustproofing.

Ordering Information:

Horizontal Panel Mounting Kit	604513-K1
Vertical Panel Mounting Kit	604513-K2

Spare Parts List:

Bezel/gasket assembly only	604513-K3
Horizontal lens cover assembly	613724-K1
Vertical lens cover assembly	613724-K2

Note: The Bezel Assembly is available as an option for mounting the 2000R units in a panel application.

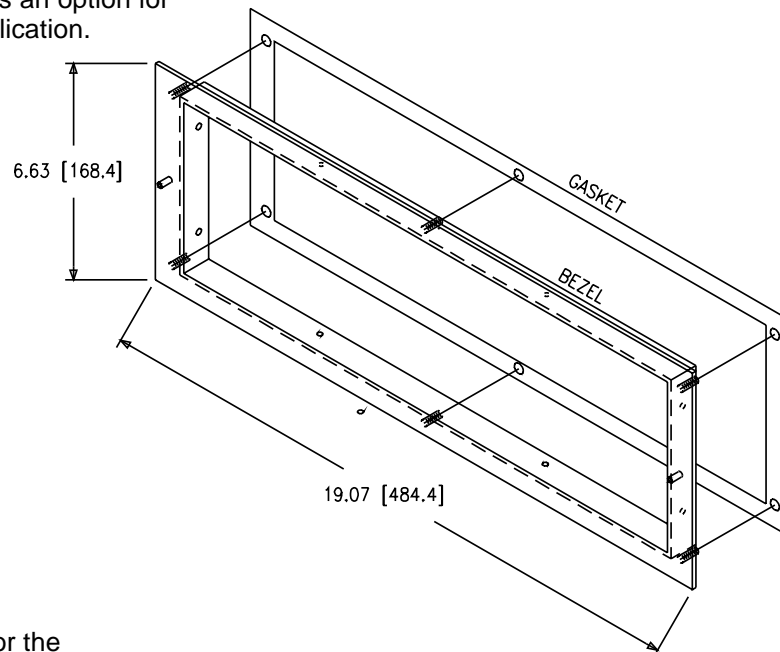

Note: Below is the panel drilling cutout for the TPU-2000R unit and the bezel assembly.

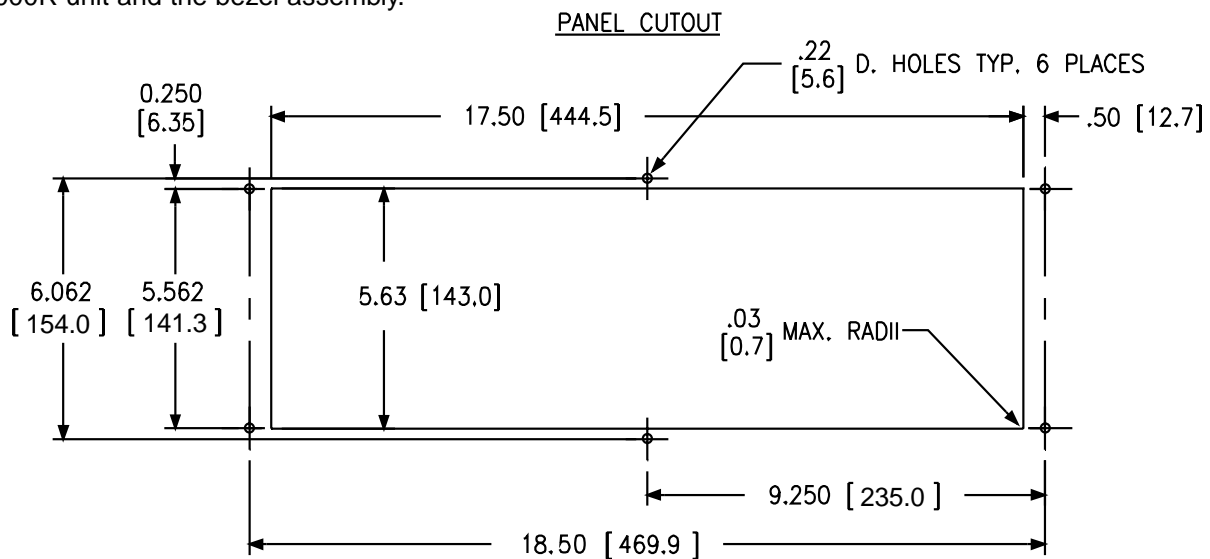

NOTE: DIMENSIONS ARE
INCHES [MILLIMETERS]

