

SPAA 120 C and SPAA 121 C Feeder protection relay

User's manual and Technical description

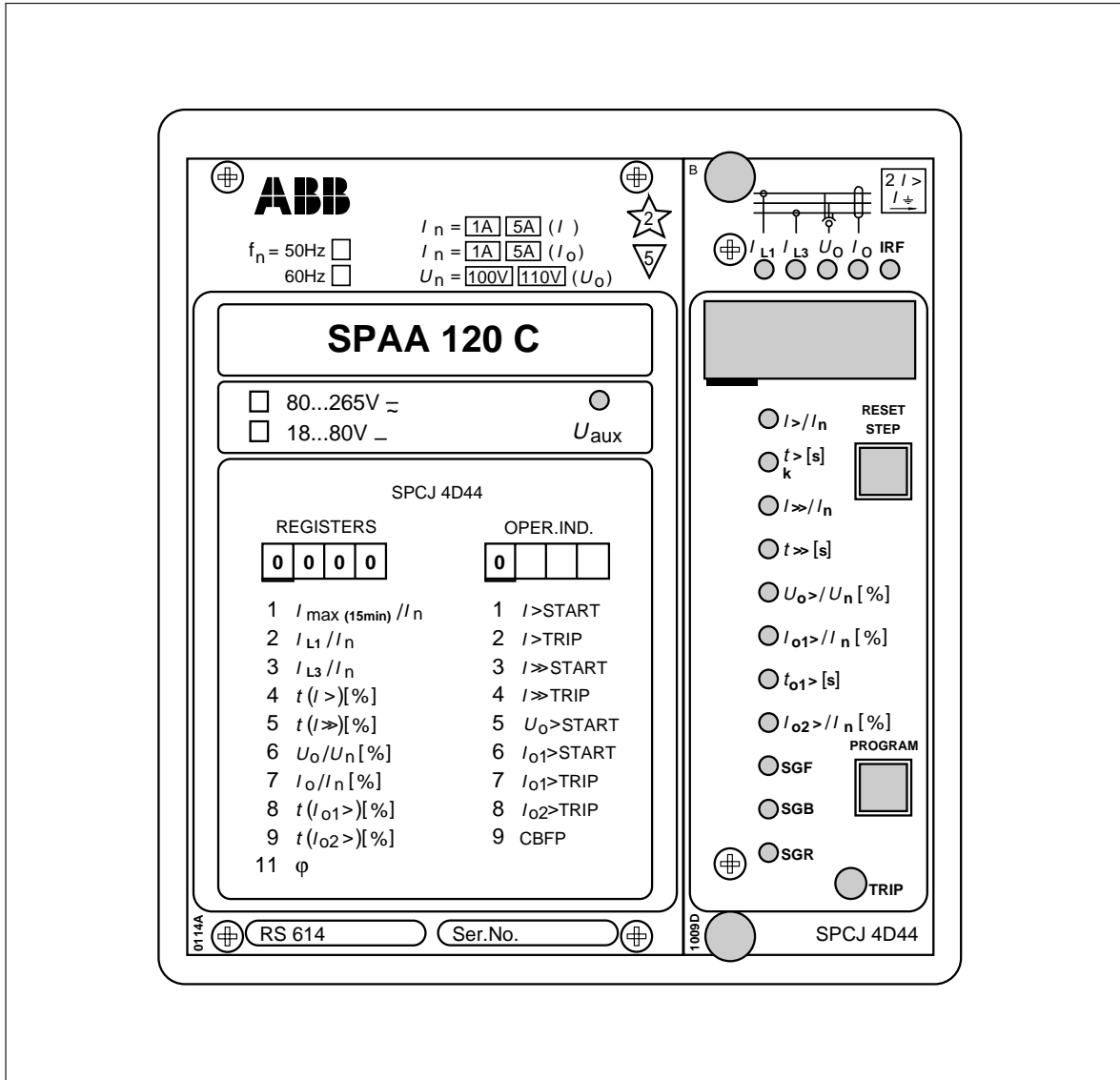

Feeder protection relay

Data subject to change without notice

Contents	Features	2
	Application	3
	Description of function	3
	Connection diagram	5
	Connections	7
	Control signals between the modules	8
	Signal abbreviations	8
	Operation indicators	9
	Power supply and output relay module	10
	Technical data	11
	Maintenance and repairs	13
	Spare parts	13
	Delivery alternatives	13
	Dimensions drawings and mounting	14
	Order data	14

Apart from this general description the complete manual for the feeder protection relay includes the following separate descriptions:

Two-phase O/C and directional E/F relay module SPCJ 4D44	1MRS 750124-MUM EN
General characteristics of D-type relay modules	1MRS 750066-MUM EN

Features	Two-phase low-set overcurrent unit with definite time or inverse time characteristic	Comprehensive fibre-optical serial communication
	Two-phase high-set overcurrent unit with instantaneous or delayed operation	Design flexibility for easy selection of appropriate operational schemes for different applications
	Directional low-set earth fault protection unit with definite time characteristic	Numerical readout of setting values, measured values, recorded fault current values, elapsed times etc.
	Directional or non-directional, high-set earth-fault stage	Continuous self-supervision of the relay including both hardware and software
	Field-configurable output relay functions	
	Integrated circuit breaker failure protection unit	

Application

The feeder protection relays type SPAA 120 C and SPAA 121 C are designed to be used for selective short-circuit and earth fault protection in radial distribution networks with isolated neutral or with resistance and/or impedance earthed neutral. The integrated feeder protection relay includes a two-phase overcurrent protection unit and a directional earth-fault protection unit. The trip and alarm signals can conveniently be connected to the output relays.

The feeder protection relay also incorporates a circuit breaker failure protection.

The feeder protection relays SPAA 120 C and SPAA 121 C have identical functions. The only difference between the two versions is the rated current of the earth fault protection unit, being 1 A and 5 A for the feeder protection relay SPAA 120 C and 0.2 A and 1 A for the feeder protection relay SPAA 121 C.

Description of function

The feeder protection relay is a secondary relay unit for connection to the current and voltage transformers of the feeder to be protected. The two-phase overcurrent unit continuously measures the two phase currents and the directional earth fault protection unit continuously measures the neutral current and the residual voltage of the protected feeder. In the event of a fault the feeder protection unit starts. After the set operate time the unit trips the circuit breaker. The operation signal of the feeder protection relay can also be used for starting an auto-reclose sequence, performed by an external co-operating auto-reclose relay.

Should one of the phase currents exceeds the setting value of the low-set overcurrent stage, the overcurrent stage starts, simultaneously starting its time circuit. When the circuit times out a trip signal is delivered to the circuit breaker.

In an earth fault situation the directional earth-fault protection unit measures the residual voltage and the neutral current, and the phase angle between them.

The earth-fault unit starts once the three criteria below are fulfilled:

- the residual voltage exceeds the set start level
- the earth-fault current exceeds the set start level
- the phase angle between residual voltage and earth-fault current is within the operation sector $\varphi_b \pm \Delta\varphi$, where φ_b is the characteristic basic angle of the network and $\Delta\varphi$ is the operation area.

When the above criteria are fulfilled, the low-set earth-fault protection stage and the time circuits start. When the time circuits have timed out a trip signal is delivered to the circuit breaker.

The high-set earth-fault protection stage operates in the same way, but can be programmed to operate as a non-directional earth-fault protection stage too. A bandpass filter incorporated in the energizing inputs of the earth fault pro-

tection unit filters out harmonics of the neutral current and the residual voltage signals before they are measured.

The low-set stage of the overcurrent unit can be given a definite time or an inverse definite time characteristic. At inverse definite time (IDMT) operation six alternative inverse time characteristics are available. Four of these characteristics, i.e. "Normal inverse, Very inverse, Extremely inverse and Long time-inverse", are in accordance with the standards BS 142 and IEC 255, whereas two of the characteristics are special-type characteristics called RI and RXIDG. The low-set stage of the earth-fault unit has a definite time characteristic with selectable operate time. The high-set stage operates instantaneously.

Note! At inverse time characteristic the effective setting range of the low-set overcurrent stage is $0.5 \dots 2.5 \times I_n$, although start current settings within the range $0.5 \dots 5.0 \times I_n$ can be set on the relay. At inverse time characteristic any start current setting above $2.5 \times I_n$ of the low-set stage will be regarded as being equal to $2.5 \times I_n$.

The output relay matrix can be configured so that start information from the overcurrent unit and the directional earth-fault unit is obtained as a contact function. This contact information can, for instance, be used as a blocking signal to be routed over to a cooperating protection relay.

The feeder protection relay is provided with a control input, which can be controlled by an external control voltage. The effect of the control input on the relay is determined by means of the function selector switches of the relay module. The control input can be used for blocking one or several protection stages, for resetting a latched output relay when manual resetting is required, or for selecting a new set of setting values for the relay.

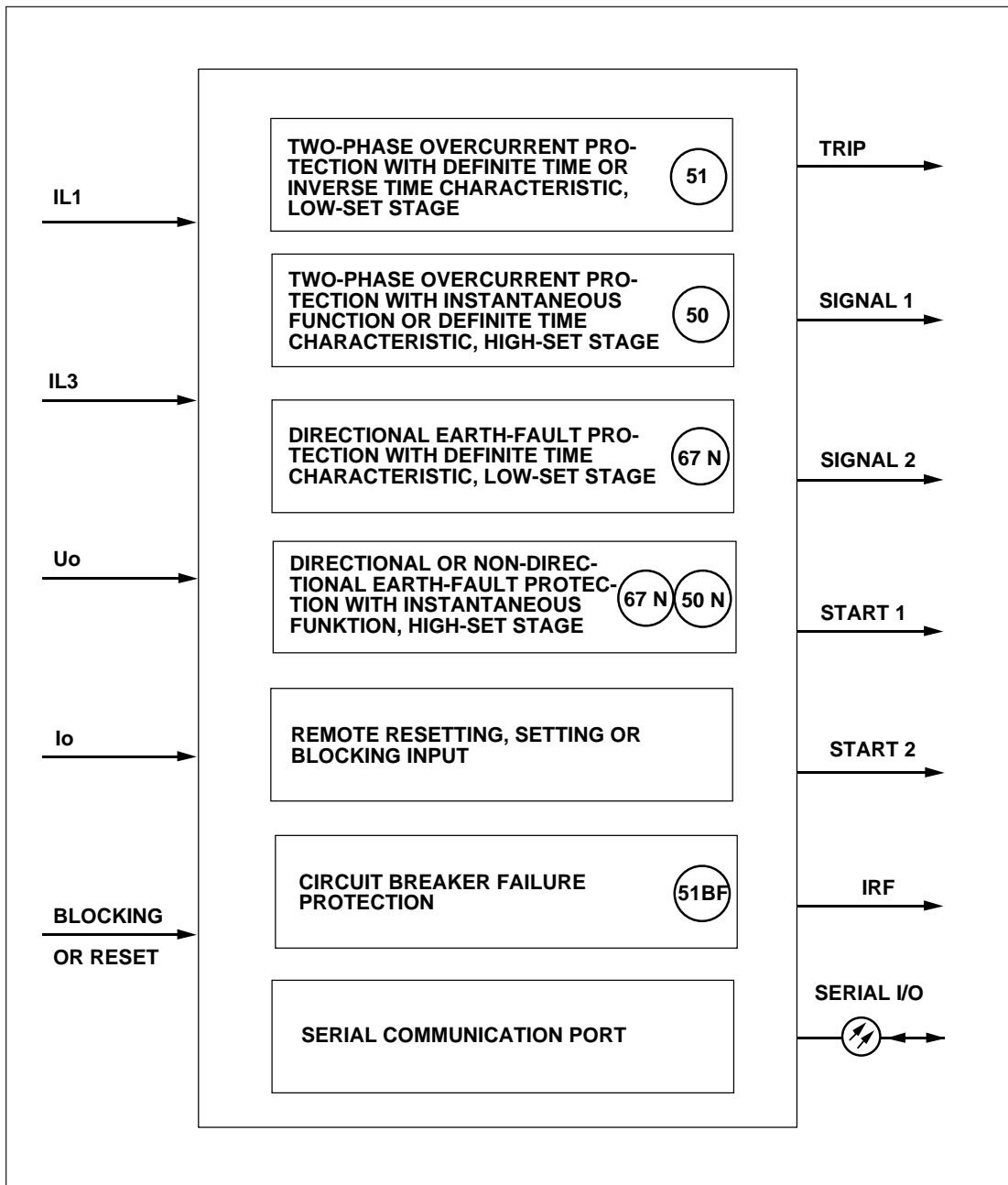

Fig. 1. Protection functions of the feeder protection relays SPAA 120 C and SPAA 121 C.

Connection diagram

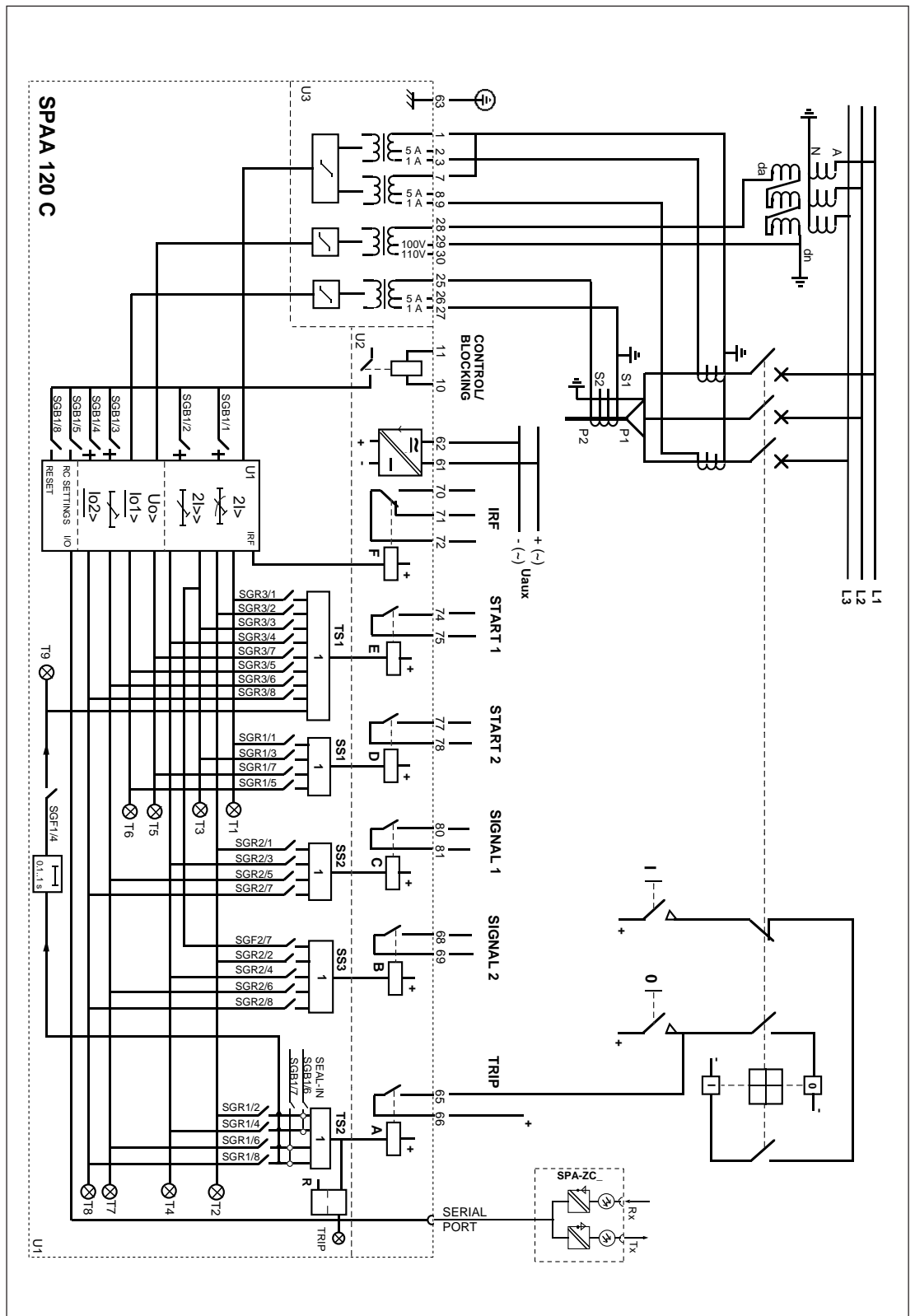

Fig. 2. Complete connection diagram for the feeder protection relay SPAA 120 C. The diagram shows the separate switches of the switchgroups. The rated current of the earth fault protection unit of the feeder protection relay SPAA 120 C is 5 A for input 25-26 and 1 A for input 25-27. For the feeder protection relay SPAA 121 C the rated current of the earth-fault unit is 1 A for input 25-26 and 0.2 A for input 25-27.

U_{aux}	Auxiliary voltage
A,B,C,D,E,F	Output relays
IRF	Signal for Internal Relay Fault
SGR1...3	Switchgroups for configuring trip and alarm signals
SGB 1	Switchgroup for configuring blocking and control signals
TRIP	Trip relay
SIGNAL 1	Signal on overcurrent tripping
SIGNAL 2	Signal on earth-fault tripping
START 1	Starting or auxiliary trip signal, as determined with switchgroup SGR3
START 2	Starting signal from overcurrent low-set stage I>
U1	Two-phase O/C and directional E/F relay module SPCJ 4D44
U3	Input/output module SPTE 4E6 (SPAA 120 C) or SPTE 4E5 (SPAA 121 C)
U2	Power supply and output relay module SPTU 240 R1 or SPTU 48 R1
RxTx	Serial interface
T1...9	Starting and trip indicators
SPA-ZC	Bus connection module

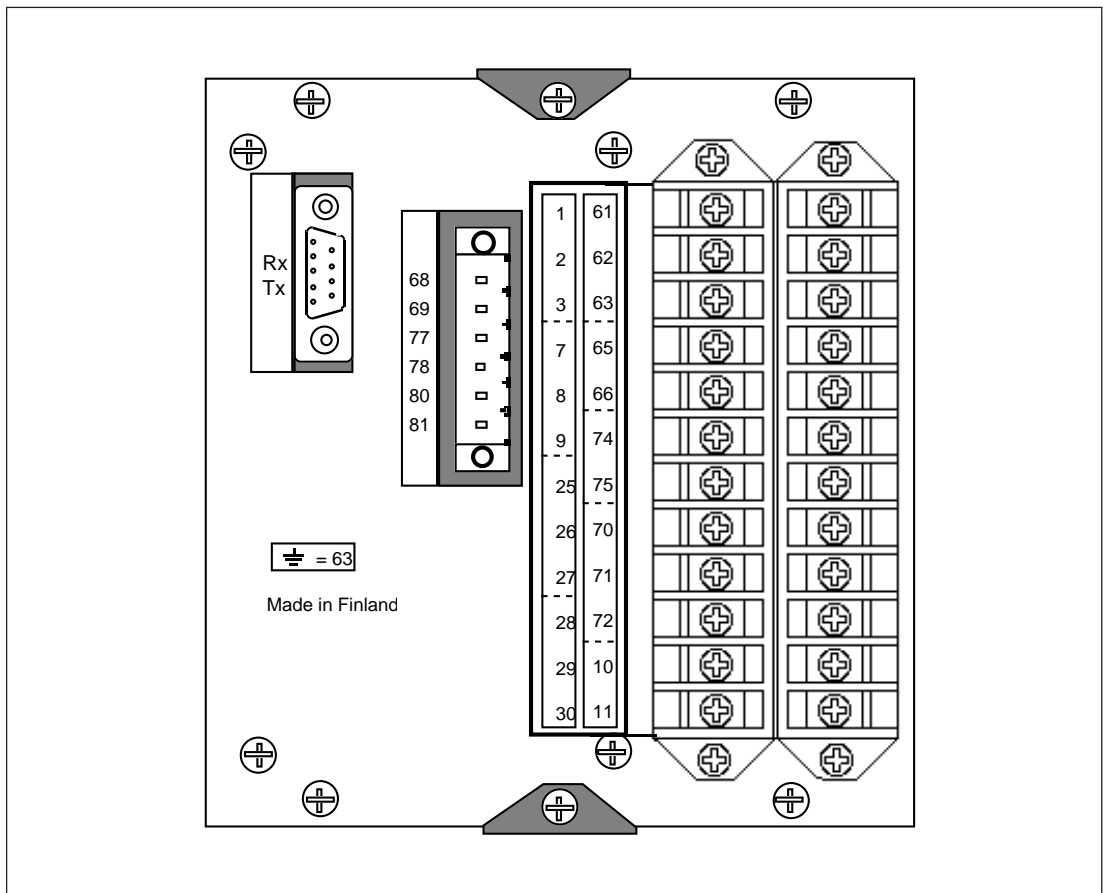

Fig. 3. Rear view of the feeder protection unit SPAA 120 C and SPAA 121 C.

Connections

Terminal number	Function
1-2	Phase current I_{L1} , 5 A
1-3	Phase current I_{L1} , 1 A
7-8	Phase current I_{L3} , 5 A
7-9	Phase current I_{L3} , 1 A
25-26	Neutral current I_0 , 5 A for SPAA 120 C and 1 A for SPAA 121 C
25-27	Neutral current I_0 , 1 A for SPAA 120 C and 0.2 A for SPAA 121 C
28-29	Residual voltage U_0 , 100 V
28-30	Residual voltage U_0 , 110 V
61-62	Auxiliary voltage. The positive lead (+) of the DC supply is connected to terminal 61.
63	Protective earth
10-11	Blocking and control input. Can be used as an external blocking input for the protection relay module, as a control input for resetting the trip relay or as a control input for remote changing of setting values. The requested function is selected with the SGB1 switches of the protection relay module.
65-66	CB open signal. The SGR switches of the protection relay module can be used for routing the trip signals from stages I>, I>>, I ₀₁ > and I ₀₂ > to relay A provided with an output contact capable of tripping. Default setting: trip contact for all protection stages.
68-69	Signal on tripping. The SGR switches of the measuring relay module can be used for routing the trip signals from stages I>, I>>, I ₀₁ > and I ₀₂ > to this contact. Default setting: signal on tripping of stages I ₀₁ > and I ₀₂ >.
80-81	Signal on tripping. The SGR switches of the measuring relay module can be used for routing the trip signals from stages I>, I>>, I ₀₁ > and I ₀₂ > to this contact. Default setting: signal on tripping of stages I> and I>>.
77-78	The SGR switches of the measuring module can be used for routing the start signals from stages I>, I>>, I ₀₁ > and I ₀₂ > to this contact. Default setting: start of stage I>.
74-75	The SGR switches of the protection relay module can be used for routing any start or trip signal of the relay to this contact capable of tripping. The relay can also be used as a tripping relay for the circuit breaker failure protection unit when this function is being used.
70-71-72	Self-supervision signal. Under normal service conditions the output relay coil is energized and the contact gap 70-72 is closed. If the self-supervision system detects an internal relay fault or there is a failure in the auxiliary supply, the contact gap 71-72 will close.

The setting possibilities of the SGB and SGR switches are described in section "Control signals between the modules".

The feeder protection relay is connected to the fibre-optical data bus by means of an optional bus connection module type SPA-ZC17 or type

SPA-ZC 21 and the 9-pole D contact on the rear panel. The fibre-optical cables are connected to the terminals Rx and Tx of the bus connection module. The fibre-optical cables connect the protection relays to the substation level control data communicator.

Control signals between the modules

Figure 4 below illustrates how the start, trip, control and blocking signals can be configured

to obtain the required functions to suit the requirements of the intended application.

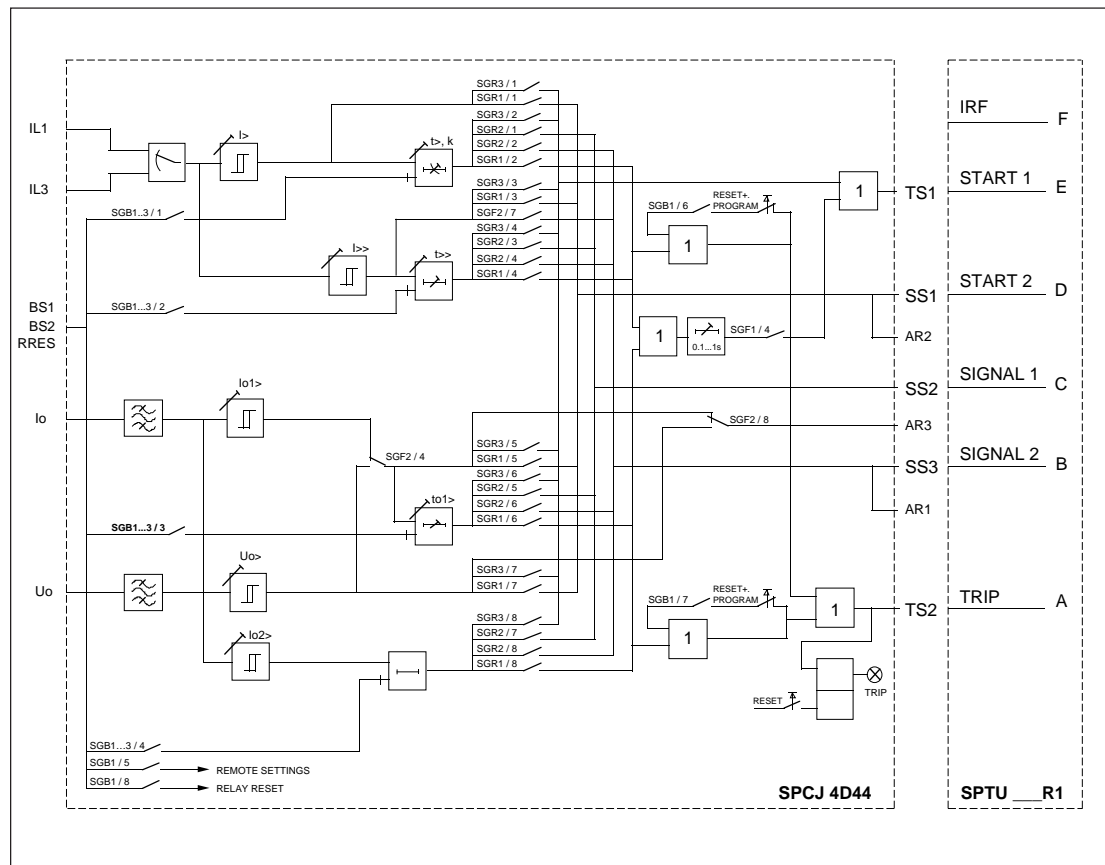

Fig. 4. Control signals between the modules of the feeder protection relays SPAA 120 C and SPAA 121 C.

The blocking and starting signals are configured with the switches of the switchgroups SGF, SGB and SGR. The checksums of the switchgroups are shown in the setting menu of the measuring

relay module. The functions of the separate switches are described in detail in the manual of the protection relay module SPCJ 4D44.

Signal abbreviations

I_{L1}, I_{L3}	Phase currents
I_0	Neutral current
U_0	Residual voltage
BS1, BS2	Blocking or control signal
SS1	Starting signal 1
SS2	Starting signal 2
SS3	Starting signal 3
TS1	Tripping signal 1
TS2	Tripping signal 2
AR1...3	Starting signals for AR functions (not used in SPAA 120 C and SPAA 121 C)
IRF	Signal for internal relay fault
SGF	Switchgroup for additional functions
SGB	Switchgroup for blocking functions
SGR	Switchgroup for output relay configuration

Operation indicators

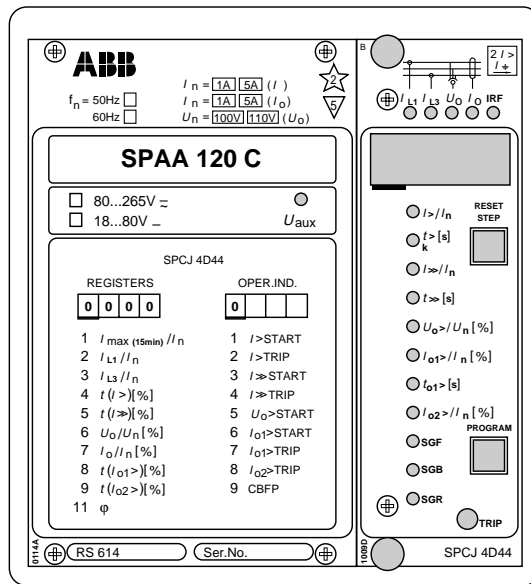

A) Operation indicator TRIP is lit when one of the protection stages has tripped. When the stage resets the red indicator remains lit.

B) If the display is dark when one of the protection stages $I>$, $I>>$, $I_0>$ or $I_0>>$ trips, the faulty phase or an earth-fault is indicated by yellow LEDs. If, for instance, the TRIP indicator is lit with red light and the yellow LEDs L1 and L3 are lit, tripping is due to overcurrent on phases L1 and L3.

C) The leftmost digit in the display acts as an address indicator for different kinds of data and as a visual operation indicator. When the display acts as an operation indicator, only the red digit in the display is lit. The table OPERATION IND. below forms a key to the operation indicator code numbers.

Display	Description
1	$I>$ START = Overcurrent low-set stage $I>$ started
2	$I >$ TRIP = Overcurrent low-set stage $I>$ tripped
3	$I>>$ START = Overcurrent high-set stage $I>>$ started
4	$I >>$ TRIP = Overcurrent high-set stage $I>>$ tripped
5	$U_0>$ START = Residual overvoltage stage started
6	$I_{01}>$ START = Neutral current low-set stage $I_{01}>$ started
7	$I_{01}>$ TRIP = Neutral current low-set stage $I_{01}>$ tripped
8	$I_{02}>$ TRIP = Neutral current low-set stage $I_{02}>$ tripped
9	CBFP = Circuit breaker failure protection tripped

D) The trip operation indicator TRIP remains lit when the protection stage resets. The indicator is reset with push-button RESET/STEP.

The operation indicators can also be reset by an external control signal applied to input 10-11, provided switch SGB1/8 is in position 1.

The protection functions are not depending on whether the operation indicators have been reset or not, but the stages are always alert.

If a protection stage starts without a consecutive trip, because the measured quantity has fallen below the set starting level before the set operation time has elapsed, the starting indicator will reset automatically. However, when required the starting indications can, by means of switches SGF3/1...4, be set to remain on after having been lit, in which case the indications are to be reset with the RESET/STEP push-button. The operation indications are continuously displayed when switches SGF3/1...4 are set as follows:

SGF3/1 = 1 Start indication of stage $I>$ remaining

SGF3/2 = 1 Start indication of stage $I>>$ remaining

SGF3/3 = 1 Start indication of stage $U_0>$ remaining

SGF3/4 = 1 Start indication of stage $I_{01}>$ remaining

On delivery of the feeder protection units the configuration switches SGF2/1...4 are in position 0.

E) When the self-supervision system of the relay detects a permanent fault, the IRF indicator will be lit. Simultaneously, a control signal is transmitted to the output relay of the self-supervision system. Further, in most fault situations, a fault code indicating the type of fault appears on the display. This fault code consisting of a red number 1 and a green code number, cannot be reset until the fault has been eliminated. To facilitate trouble-shooting and repair the fault codes should be noted.

Power supply and output relay module

To be able to operate the feeder protection relay needs a secured auxiliary voltage supply. The power supply and output relay module forms the voltages required by the relay module and the output relays. The power supply and the output relay module is a separate plug-in unit located behind the system panel. The module incorporates a power supply unit, the output relays with their control circuits, and the electronics for the external control input.

The power supply and output relay module can be withdrawn from the relay case when the system panel has been removed after unwinding four cross-slotted screws.

The power supply and output relay module is a transformer connected, flyback-type DC/DC converter with galvanically isolated primary and secondary side. The primary side of the power supply module is protected by a 1 A fuse (slow), F1, located on the PCB of the module.

The power supply and output relay module forms the secondary voltages required by the measuring relay module and the output relays: +24 V, ± 12 V and +8 V. The output voltages ± 12 V and +24 V have been stabilized in the power supply module, while the +5 V logics voltage required by the modules is stabilized in the concerned relay module.

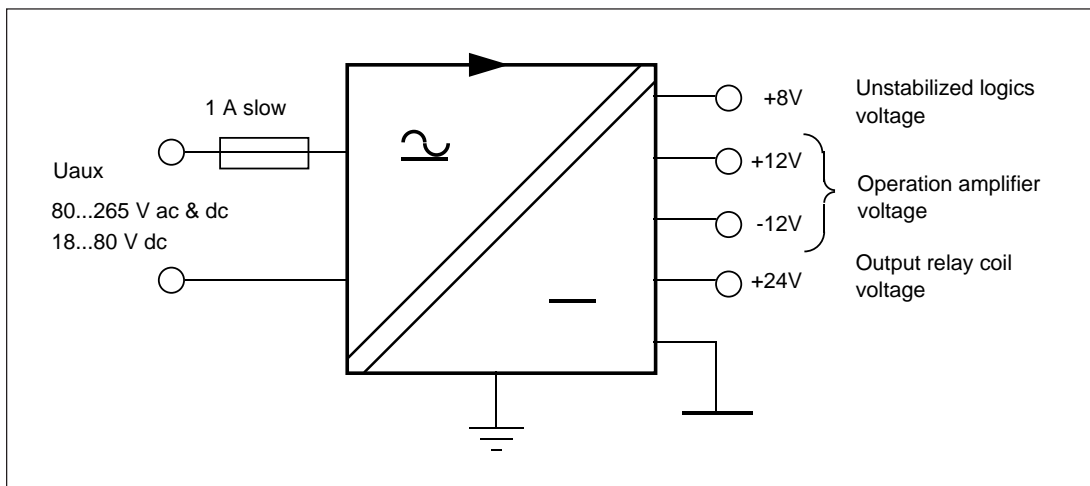

Fig. 5. Voltage levels of the power supply module.

A green LED indicator U_{aux} on the system panel is lit when the power supply module is in operation. The voltages supplying the electronics are supervised in the measuring modules. If a secondary voltage considerably deviates from its rated value a self-supervision alarm will be given. An alarm signal will also be generated, if the power supply module is withdrawn from the case or the auxiliary power supply to the relay is interrupted.

Two power supply module versions are available. The secondary voltages of the two power supply modules are identical, while the input voltage ranges are different.

The insulation test voltage between primary and secondary side and protective earth is 2 kV, 50 Hz, 1 min and the rated power P_n is 5 W.

Input voltage ranges of the power supply and output relay modules:

- SPTU 240R1 $U_{aux} = 80...265$ V dc/ac
- SPTU 48R1 $U_{aux} = 18...80$ V dc

The SPTU 240R1 module can be used for both ac and dc supply, whereas SPTU 48R1 is designed for dc supply only. The system panel of the relay unit shows the input voltage range of the supply module of the relay unit.

Technical data**Energizing inputs**

Energizing inputs of SPAA 120 C		
Phase current inputs	1-3, 7-9	1-2, 7-8
Neutral current inputs	25-27	25-26
Rated current I_n	1 A	5 A
Thermal current withstand		
- continuously	4 A	20 A
- for 10 s	25 A	100 A
- for 1 s	100 A	500 A
Dynamic current withstand		
- 10 ms value	250 A	1250 A
Input impedance	$\leq 100 \text{ m}\Omega$	$\leq 20 \text{ m}\Omega$
Energizing inputs of SPAA 121 C		
Neutral current inputs	25-27	25-26
Rated current I_n	0.2 A	1 A
Thermal current withstand		
- continuously	1.5 A	4 A
- for 10 s	5 A	25 A
- for 1 s	20 A	100 A
Dynamic current withstand		
- 10 ms value	50 A	250 A
Input impedance	$\leq 750 \text{ m}\Omega$	$\leq 100 \text{ m}\Omega$
Input terminals	28-29	28-30
Rated voltage U_n	100 V	110 V
Continuous voltage carrying capacity	$2 \times U_n$	$2 \times U_n$
Power drain of energizing input at rated voltage	$\leq 0.5 \text{ VA}$	$\leq 0.5 \text{ VA}$
Rated frequency		
According to order, f_n	50 Hz or 60 Hz	

Output contact ratings

Tripping contacts	65-66, 74-75
Rated voltage	250 V ac or dc
Continuous carry	5 A
Make and carry for 0,5 s	30 A
Make and carry for 3,0 s	15 A
Breaking capacity for dc, when the control circuit time constant $L/R \leq 40 \text{ ms}$ at 48/110/220 V dc	5 A/3 A/1 A
Signalling contacts	70-71-72, 68-69, 77-78, 80-81
Rated voltage	250 V ac or dc
Continuous carry	5 A
Make and carry for 0,5 s	10 A
Make and carry for 3,0 s	8 A
Breaking capacity for dc, when the control circuit time constant $L/R \leq 40 \text{ ms}$ at 48/110/220 V dc	1 A/0.25 A/0.15 A

External control inputs

Blocking, remote reset or remote setting input	10-11
External control voltage level	18...265 V dc or 80...265 V ac
Typical control current of activated control input	2 mA

Data transmission

Transmission mode	Fibre optic serial bus
Data code	ASCII
Data transfer rate	4800 or 9600 Bd
Bus connection module with external supply	
- for plastic fibre cables	SPA-ZC 17 BB2_
- for plastic/glass fibre cables	SPA-ZC 17 BM2_
- for glass/plastic fibre cables	SPA-ZC 17 MB2_
- for glass fibre cables	SPA-ZC 17 MM2_
Bus connection module without external supply	
- for plastic fibre cables	SPA-ZC 21 BB
- for plastic/glass fibre cables	SPA-ZC 21 BM
- for glass/plastic fibre cables	SPA-ZC 21 MB
- for glass fibre cables	SPA-ZC 21 MM

Power supply modules

Type SPTU 240R1	80...265 V ac or dc
Type SPTU 48R1	18...80 V dc
Power consumption under quiescent/operating conditions	about 4 W/6 W

Measuring relay module SPCJ 4D44

See "Technical Data" for the relay module

Insulation Tests *)

Dielectric test IEC 60255-5	2 kV, 50 Hz, 1 min
Impulse voltage test IEC 60255-5	5 kV, 1.2/50 μ s, 0.5 J
Insulation resistance measurement IEC 60255-5	>100 M Ω , 500 Vdc

Electromagnetic Compatibility Tests *)

High-frequency (1 MHz) burst disturbance test IEC 60255-22-1	
- common mode	2.5 kV
- differential mode	1.0 kV
Electrostatic discharge test IEC 60255-22-2 and IEC 61000-4-2	
- contact discharge	6 kV
- air discharge	8 kV
Fast transient disturbance test IEC 60255-22-4 and IEC 61000-4-4	
- power supply	4 kV
- I/O ports	2 kV

Environmental conditions

Specified ambient temperature	-10...+55°C
Temperature influence on the operating values of the relay over the specified ambient service temperature range	<0.2 % /°C
Long-term damp heat withstand acc. to IEC 60068-2-3	≤95 % at +40°C for 56 days
Transport and storage temperature range	-40...+70°C
Degree of protection by enclosure of the relay case when panel mounted	IP 54
Mass of the relay unit	4.5 kg

*) The tests do not apply to the serial port, which is used exclusively for the bus connection module.

Maintenance and repairs

When the feeder protection relay is used under the conditions specified in "Technical data", the relay requires practically no maintenance. The feeder protection includes no parts or components that are sensitive to physical or electrical wear under normal operating conditions.

Should the temperature and humidity at the operating site differ from the values specified, or the atmosphere contain chemically active gases or dust, the relay should be visually inspected in association with the secondary testing of the relay. This visual inspection should focus on:

- Sign of mechanical damage to relay case and terminals
- Collection of dust inside the relay case; remove with compressed air
- Sign of corrosion on terminals, case or inside the relay

If the relay malfunctions or the operating values differ from those specified, the relay should be overhauled. Minor measures can be taken by the customer but any major repair involving the electronics has to be carried out by the manufacturer. Please contact the manufacturer or his nearest representative for further information about checking, overhaul and recalibration of the relay.

The protection relay contains circuits sensitive to electrostatic discharge. If you have to withdraw a relay module, ensure that you are at the same potential as the module, for instance, by touching the case.

Note!

Protective relays are measuring instruments and should be handled with care and protected against moisture and mechanical stress, especially during transport.

Spare parts	Relay module	SPCJ 4D44
	Power supply module	
	- $U_{aux} = 80...265$ V ac or dc	SPTU 240R1
	- $U_{aux} = 18...80$ V dc	SPTU 48R1
	Matching module	SPTU 4E6 (SPAA 120 C)
		SPTU 4E5 (SPAA 121 C)
	Bus connection module with external supply	
	- for plastic fibre cables	SPA-ZC 17 BB2_
	- for plastic/glass fibre cables	SPA-ZC 17 BM2_
	- for glass/plastic fibre cables	SPA-ZC 17 MB2_
	- for glass fibre cables	SPA-ZC 17 MM2_
	Bus connection module without external supply	
	- for plastic fibre cables	SPA-ZC 21 BB
	- for plastic/glass fibre cables	SPA-ZC 21 BM
	- for glass/plastic fibre cables	SPA-ZC 21 MB
	- for glass fibre cables	SPA-ZC 21 MM

Delivery alternatives	Feeder protection unit	
	Type SPAA 120 C	RS 614 101 - AA, CA, DA, FA
	Type SPAA 121 C	RS 614 102 - AA, CA, DA, FA
	Feeder protection unit with test switch RTXP 18	
	Type SPAA 120 C + RTXP 18	RS 614 301 - AA, CA, DA, FA
	Type SPAA 121 C + RTXP 18	RS 614 302 - AA, CA, DA, FA

The letter combinations of the order number denote the rated frequency f_n and auxiliary voltage U_{aux} of the protection relay:

- AA $f_n = 50$ Hz and $U_{aux} = 80...265$ V ac/dc
- CA $f_n = 50$ Hz and $U_{aux} = 18...80$ V dc
- DA $f_n = 60$ Hz and $U_{aux} = 80...265$ V ac/dc
- FA $f_n = 60$ Hz and $U_{aux} = 18...80$ V dc

Power supply module	
SPTU 240R1, $U_{aux} = 80...265$ V ac/dc	RS 941 020 - AA
SPTU 48R1, $U_{aux} = 18...80$ V dc	RS 941 020 - BA

Dimension drawings and mounting

The basic model of the relay case is intended for flush-mounting. When required, the mounting depth of the case can be reduced behind the panel by using raising frames: type SPA-ZX 111 reduces the depth by 40 mm, type SPA-ZX 112 by 80 mm and SPA-ZX 113 by 120 mm.

A relay case for projecting mounting with the type designation SPA-ZX 110 is delivered on request.

The relay case is made of an extruded aluminium profile and finished in beige.

The mounting frame with a rubber gasket provides a degree of protection by enclosure according to IP54 between the relay case and the panel surface when the relay is panel mounted.

The hinged cover of the case is made of transparent, UV-stabilized polycarbonate polymer and provided with a sealable finger screw. The degree of protection by enclosure of the cover is also IP54.

A terminal strip and two multiple connectors are fitted on the rear of the relay case to facilitate input and output connections. To each heavy duty terminal, i.e. measuring inputs, power supply or trip output, one or two 2.5 mm² wires can be connected. No terminal lugs are needed. The signalling outputs are available on a six-pole detachable connector and the serial communication bus is connected over a 9-pole D-type connector.

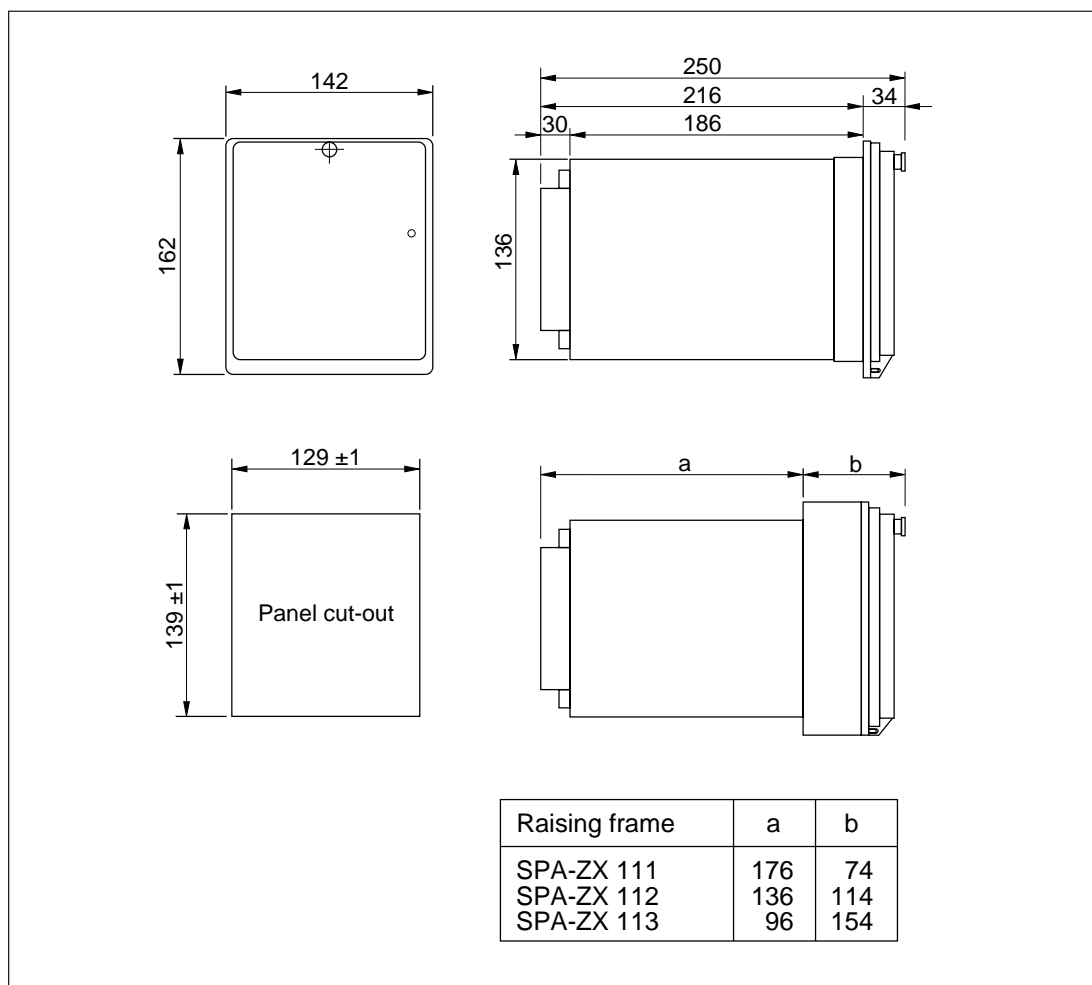

Order data

1. Number and type designation
2. Order number
3. Rated frequency
4. Auxiliary voltage
5. Accessories
6. Special requirements

Example

15 pcs SPAA 120 C
 RS 614 101 - AA
 $f_n = 50$ Hz
 $U_{aux} = 110$ V dc
 15 pcs bus connection modules SPA-ZC 17 MM
 —

SPCJ 4D44

Overcurrent relay module

User's manual and Technical description

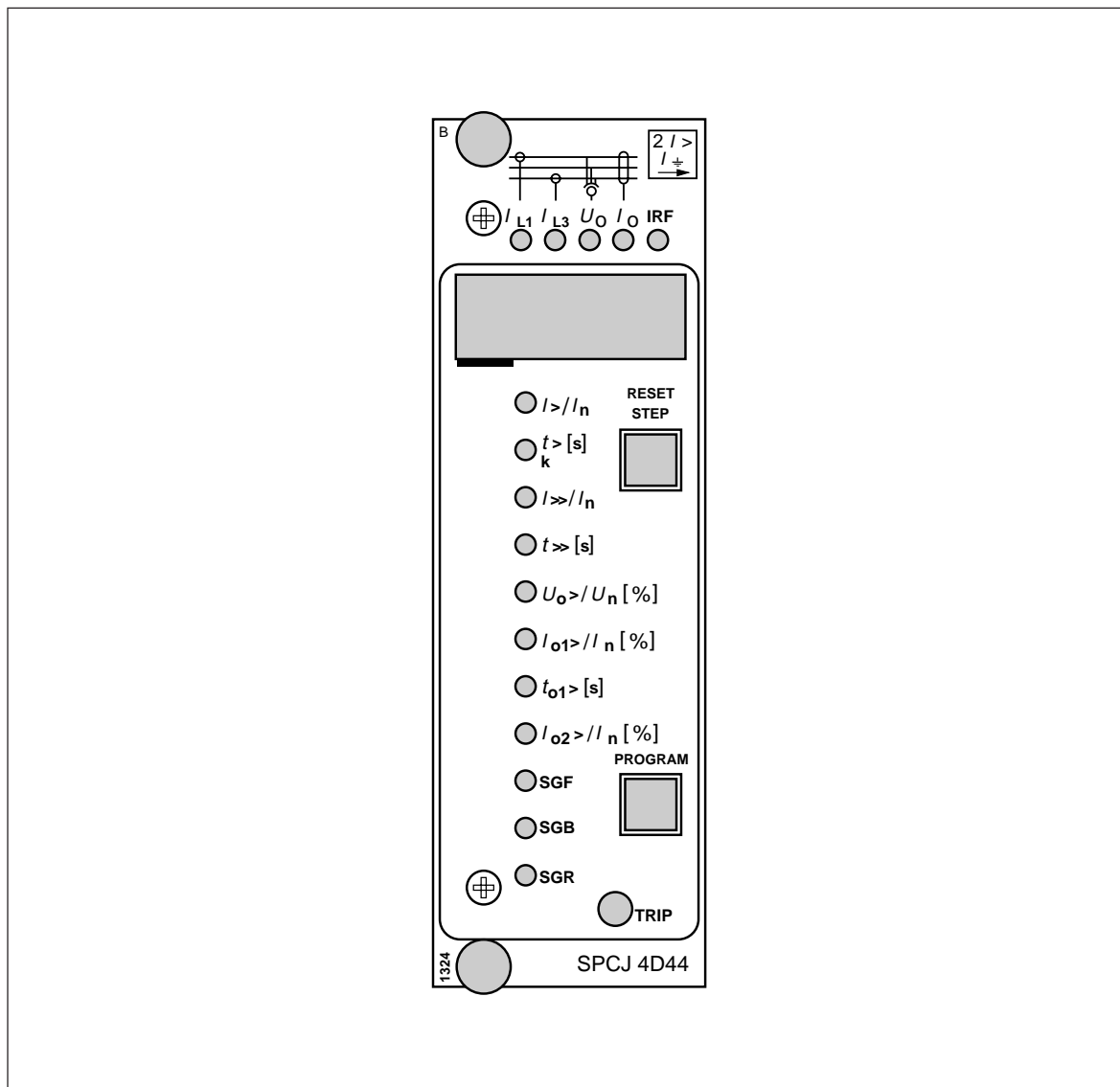

SPCJ 4D44

Non-directional phase and directional neutral overcurrent relay module

Data subject to change without notice

Contents	Characteristics	2
	Description of operation	3
	Block diagram	7
	Front panel	8
	Operation indicators	9
	Relay settings	10
	Function selector switches	11
	Measured data	17
	Recorded data	18
	Main menus and submenus of settings and registers	20
	Time/current characteristics	22
	Technical data	30
	Event codes	31
	Data to be transferred over the serial bus	33
	Fault codes	38
	Appendix 1	39
	Appendix 2	40
	Technical data affected by versions SW 089 E, F	46
	Recommendation for configuring the module SPCJ 4D44 SW 089 F	46

Characteristics	Low-set phase overcurrent stage I _{>} with definite time and inverse time characteristic	Digital display of measured quantities, relay setting values and sets of data recorded during fault situations
	High-set phase overcurrent stage I _{>>} with instantaneous operation or definite time characteristic	All settings may be entered either using the push-buttons and the display on the front panel of the module or a personal computer
	Directional low-set neutral overcurrent stage I _{01>} with definite time characteristic	Continuous self-supervision including both module hardware and software. At a permanent fault the alarm output relay operates and the other relay outputs are blocked.
	Directional or non-directional high-set neutral overcurrent stage I _{02>}	

Description of operation

Overcurrent unit

The overcurrent unit of the combined overcurrent and directional earth-fault relay module SPCJ 4D44 is designed for single-phase or two-phase operation. It contains two overcurrent stages, i.e. a low-set stage $I_{>}$ and a high-set-stage $I_{>>}$.

The low-set or high-set stage starts if the current on one of the phases exceeds the setting value of the stage concerned. When starting the concerned stage provides a start signal and simultaneously the digital display on the front panel indicates starting. If the overcurrent situation lasts long enough to exceed the set operate time, the stage that started calls for CB tripping by providing a tripping signal. At the same time the operation indicator LED goes on with a red light. The red operation indicator remains lit although the stage resets.

The operation of both overcurrent stages can be blocked by applying a blocking signal BS1, BS2 or RRES to the unit. The blocking configuration is set by means of switchgroups SGB1, SGB2 and SGB3.

The operation of the low-set stage $I_{>}$ can be based on a definite time or inverse time characteristic. The mode of operation is programmed with switches SGF1/1...3. At definite time mode of operation the operating time $t_{I_{>}}$ is set in seconds within the setting range 0.05...300 s. When inverse time mode of operation (IDMT) is used four internationally standardized and two special type time/current characteristics are available. The programming switches SGF1/1...3 are also used for selecting the desired operation characteristic.

Note !

If the setting is higher than $2.5 \times I_n$, the maximum continuous carry $4 \times I_n$ and the levelling out of the IDMT curves at high current levels must be noted.

CAUTION !

Never use start current settings above $2.5 \times I_n$ at inverse time characteristic, although allowed by the relay.

Note !

The high-current end of any inverse time characteristic is determined by the high-set stage which, when started, inhibits the low-set stage operation. Thus, the trip time is equal to the set operate time $t_{I_{>>}}$ for any current higher than $I_{>>}$. In order to get a trip signal, the stage $I_{>>}$ must also, of course, be linked to a trip output relay.

The operate time of the high-set stage $t_{I_{>>}}$ is separately set within the range 0.04...300 s.

The operation of both overcurrent stages is provided with a latching facility keeping the tripping output energized, although the signal which caused the operation disappears. The output relays can be reset in five different ways; a) by pressing the PROGRAM push-button, b) by pressing the RESET and PROGRAM push-buttons simultaneously, by remote control over the SPA bus using c) the command V101 or d) the command V102 and further e) by remote control over the external control input. When a) or c) is used no stored data are erased, but when resetting according to b), d) or e) is used the recorded data are erased.

The setting value of the high-set stage $I_{>>}$ may be subject to automatic doubling when the protected object is connected to the network, i.e. in a starting situation. Thus the setting value of the $I_{>>}$ stage may be lower than the connection inrush current. The automatic doubling function is selected with switch SGF1/5. The starting situation is defined as a situation where the phase currents increase from a value below $0.12 \times I_{>}$ to a value exceeding $1.5 \times I_{>}$ in less than 60 ms. The starting situation ends when the currents fall below $1.25 \times I_{>}$.

The operation of the high-set stage may be set out of operation by means of switch SGF1/7. When the high-set stage is out of operation the display shows a "- - -" readout, indicating that the operating value is infinite.

The directional earth-fault unit of the phase overcurrent and earth-fault relay module SPCJ 4D44 includes two protection stages: a low-set current stage $I_{01}>$ and a high-set current stage $I_{02}>$.

The directional earth-fault unit measures the neutral current I_0 , the residual voltage U_0 and the phase angle between residual voltage and neutral current. A protection stages starts if all of the three criteria below are fulfilled:

- the residual voltage U_0 exceeds the start level set for the $U_0>$ stage. The setting is the same for the stages $I_{01}>$ and $I_{02}>$.
- the neutral current I_0 exceeds the set start value of stage $I_{01}>$ or stage $I_{02}>$.
- if the phase angle between residual voltage and neutral current falls within the operation sector $\varphi_b \pm \Delta\varphi$, where φ_b is the characteristic basic angle of the network and $\Delta\varphi$ is the operation area.

The setting value of the characteristic basic angle φ_b of the network is selected according to the earthing principle used in the network, that is, -90° for isolated neutral networks, and 0° for

resonant-earthed networks, which are earthed through an arc suppression coil (Petersen coil), with or without a parallel resistor.

The operation sector $\Delta\varphi$ can be set to $\pm 80^\circ$ or $\pm 88^\circ$ for both stages.

Note!

If $I_0 < 3\% I_n$ and $SGF3/5 = 0$ then the operation sector $\Delta\varphi = \pm 70^\circ$.

When an earth-fault stage starts a starting signal is obtained and, simultaneously, the digital display on the front panel indicates starting. If the above mentioned criteria are fulfilled long enough to exceed the set operation time, the stage that started delivers a tripping signal. At the same time the operation indicator on the front panel is lit. The red operation indicator remains lit although the protection stage resets. On the basis of the angle between voltage and current, the direction towards the fault spot is determined, see Fig. 1 below.

The $I_{02}>$ stage can also be configured to measure the intermittent earth faults. See appendix 1.

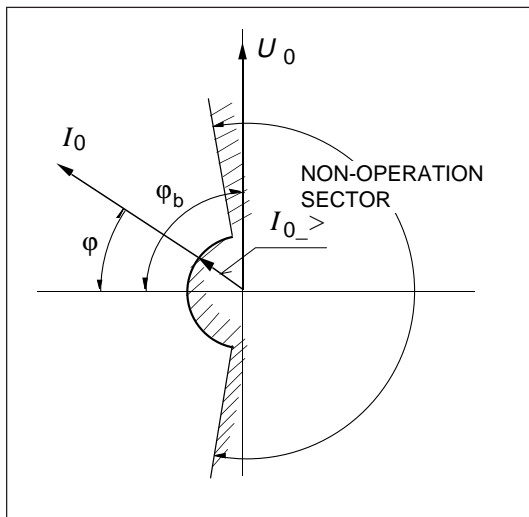

Fig.1a. Operation characteristic of the directional earth-fault protection unit, when the basic angle $\varphi_b = -90^\circ$.

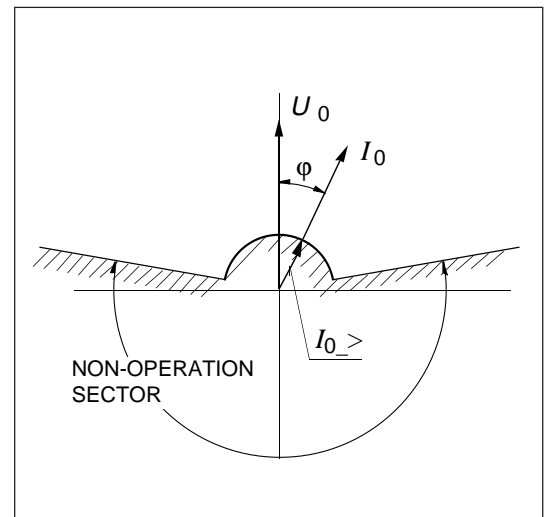

Fig.1b. Operation characteristic of the directional earth-fault protection unit, when the basic angle $\varphi_b = 0^\circ$.

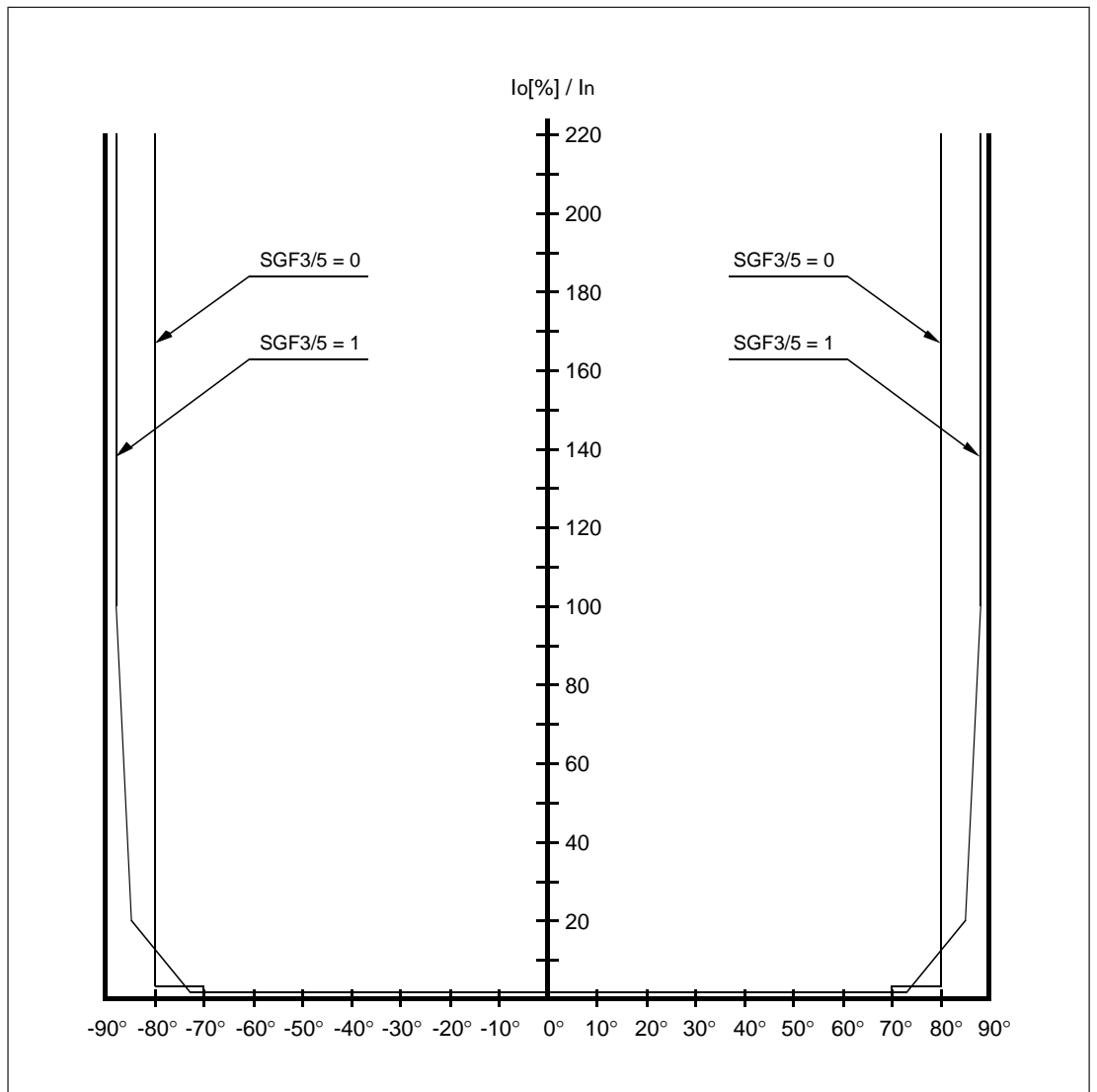

Fig.1c. Operation characteristic of the directional earth-fault protection unit of the relay module SPCJ 4D44 shown in an I_0 - φ diagram with the characteristic angle $\varphi_b = 0^\circ$.

The basic angle φ_b i.e. -90° , -60° , -30° or 0° is set with the switches SGF2/1...2.

Harmonics of the neutral current measured by the earth-fault unit are effectively filtered out by means of a bandpass filter. The third harmonic, for example, is reduced by 17 dB of its original value. Harmonics of higher order are suppressed even more.

The operation of the protection stages can be blocked by routing a blocking signal BS1, BS2 or RRES to the concerned protection stage. Switchgroups SGB1, SGB2 or SGB3 are used for configuring the blocking signals.

The operation direction of the earth fault stages can be selected independently of each other by using switches SGF2/3 and SGF2/5.

The operation time $t_{01}>$ of the low-set stage $I_{01}>$ is set within the range 0.1...300 s. The operation time of the high-set stage is preset and <100 ms.

The outputs of both neutral overcurrent stages are provided with a latching feature keeping the operation output energized, though the fault signal which caused the operation of the protection has disappeared. The output relays can be reset in five different ways; a) by pressing the PROGRAM push-button, b) by pressing the RESET and PROGRAM push-buttons simultaneously, by remote control over the SPA bus using c) the command V101 or d) the command V102 and further e) by remote control over the external control input. When a) or c) is used no recorded data are erased, but when resetting according to b), d) or e) is used the recorded data are erased.

Note!

The function described in the chapter "Earth-fault unit" applies to program versions SW089 A and B. For program versions SW 089 C and D, see Appendix 1, page 39. An optional function for the detection of intermittent earth faults has been added to the earth-fault stage $I_{02}>$.

For program version SW 089 F and later, see Appendix 2, page 40. Some changes have been made to the earth-fault stages $I_{01}>$ and $I_{02}>$ in order to improve the protective functions for the faulted line and healthy lines.

The operation of the high-set stage $I_{02}>$ may be set out of operation by means of switch SGF1/8. When the stage is out of operation the display shows a "- -", indicating that the operation value is infinite.

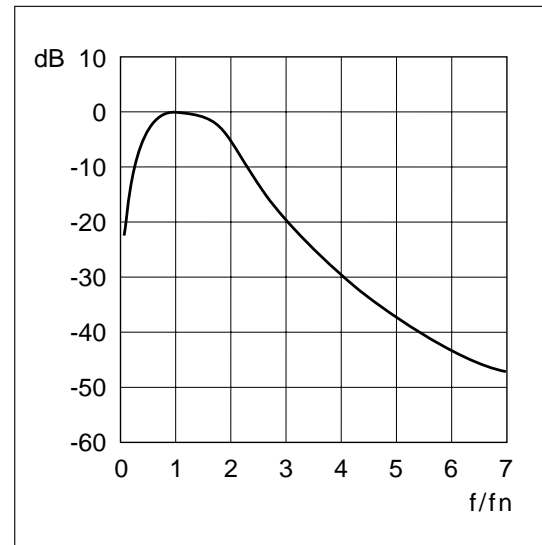

Fig. 2. Filter characteristics of the energizing inputs of the residual current I_0 and voltage U_0 of the relay module.

Circuit breaker failure protection

The relay module is also provided with a circuit breaker failure protection (CBFP), which provides a tripping signal via TS1 after the set operation time 0.1...1 s counted from the normal tripping signal TS2, if the fault has not been cleared within that time. The operation time of the circuit breaker failure protection is set in Register A, submenu 5. The output contact of

the circuit breaker failure protection is normally used for tripping an upstream circuit breaker. The CBFP can also be used for establishing a redundant trip system by providing the circuit breaker with two tripping coils one being controlled by TS2 and the other by TS1. The circuit breaker failure protection is taken into use or taken out of use by means of switch SGF1/4.

Block diagram

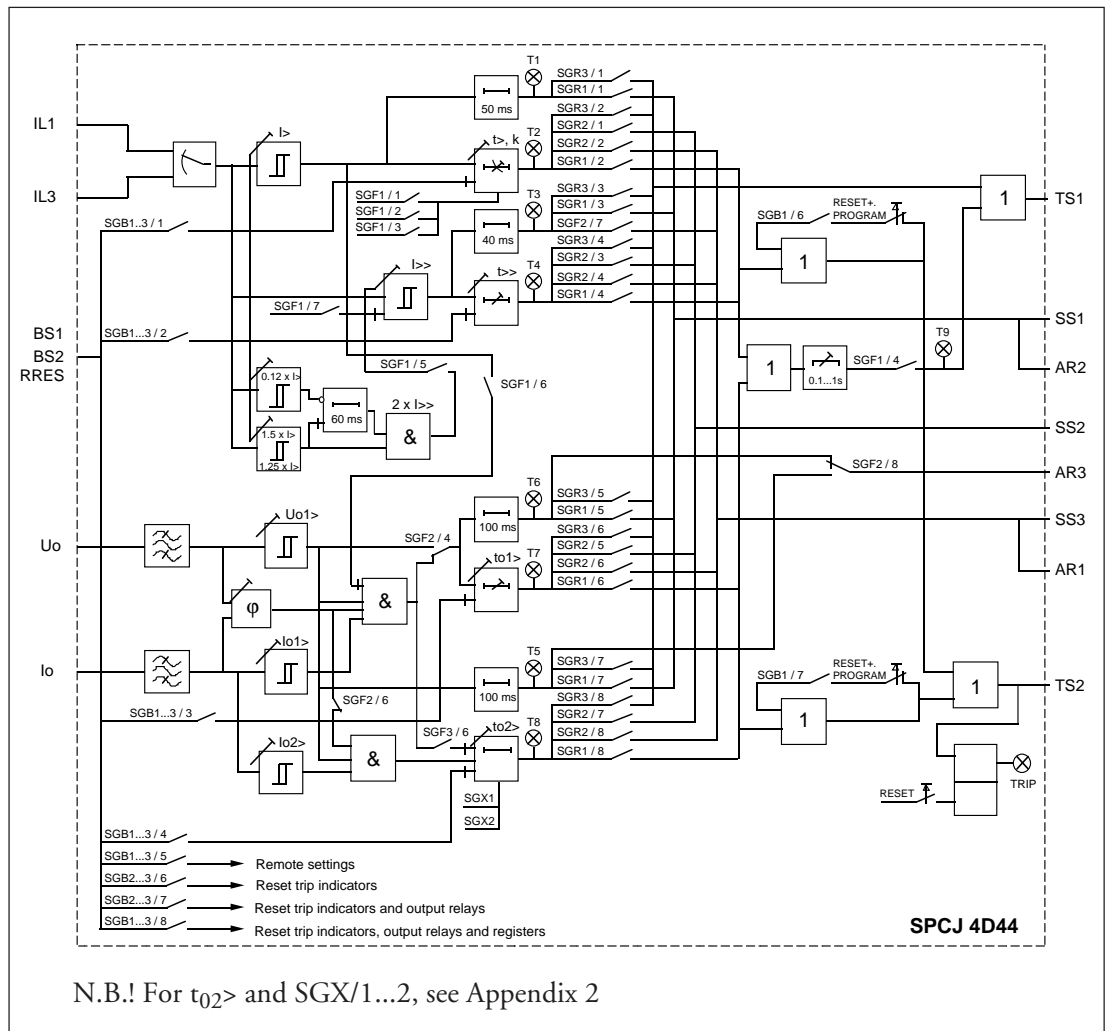

Fig 3. Block diagram for the two-phase phase overcurrent and earth-fault relay module SPCJ 4D44.

I_{L1}, I_{L3}	Measured phase currents
I_0	Measured neutral current
U_0	Measured residual voltage
BS1, BS2 and RRES	External blocking or resetting signals
SGF1...3	Programming switchgroups SGF1...SGF3
SGB1...3	Programming switchgroups SGB1...SGB3
SGR1...3	Programming switchgroups SGR1...SGR3
SS1...SS3,	Output signals
TS1, TS2	
TRIP	Operation indicator

Note !

All input and output signals of the module are not necessarily wired to the terminals of every protection relay unit using this module. The signals wired to the terminals are shown in the diagram illustrating the flow of signals between the various modules of the protection relay unit.

Front panel

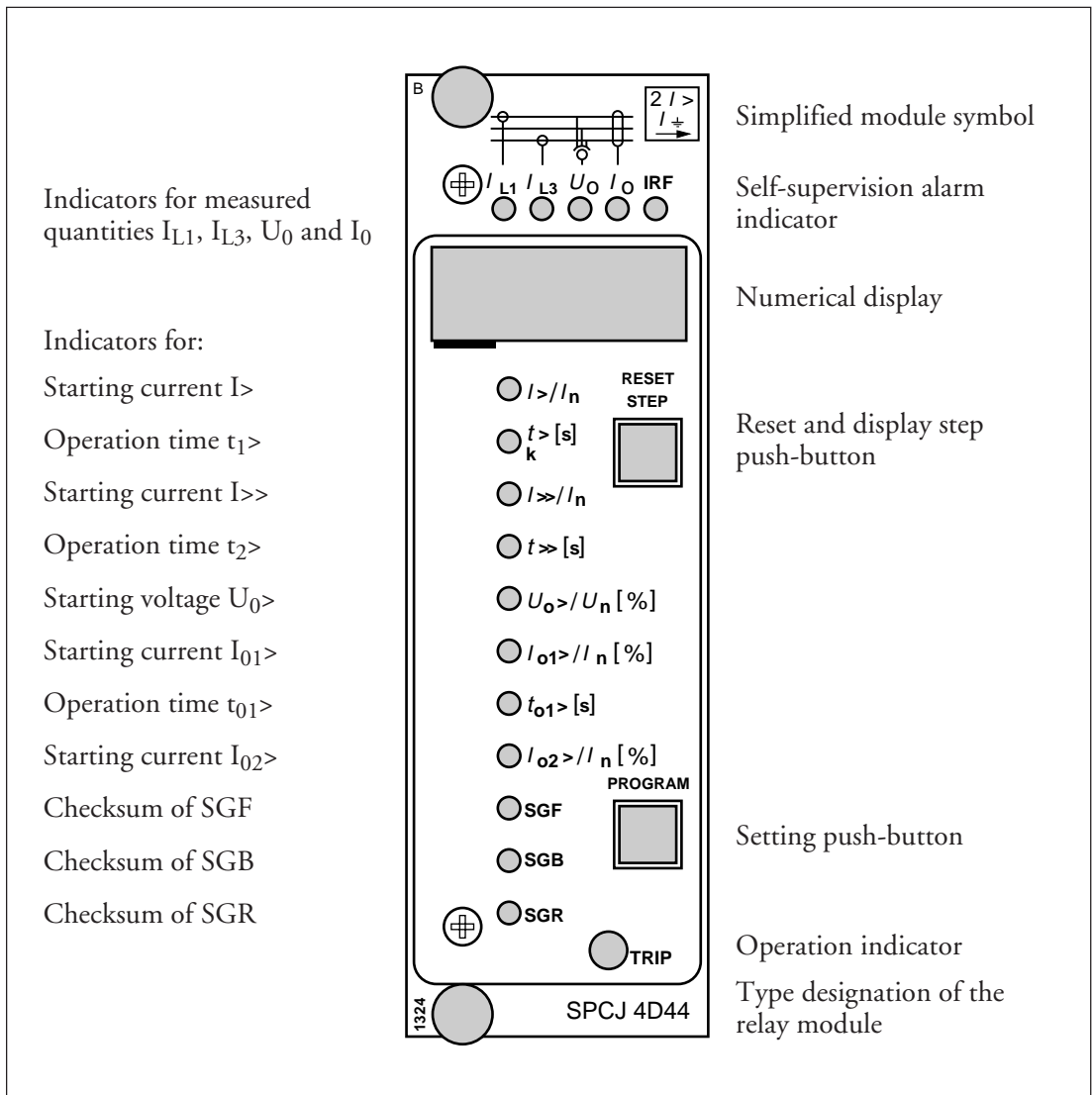

Fig 4. Front panel of the two-phase overcurrent and directional earth-fault module SPCJ 4D44.

Operation indicators

Each stage has its own starting indicator and operation indicator shown as a number on the display. Further all stages operate with a common LED operation indicator named "TRIP", glowing red when indicating that the module has operated.

The number indicating operation remains lit on the display when the protection stage resets, thus indicating that a certain protection stage has operated.

If the start situation of a stage is not long enough to cause a trip, the starting indication is normally self-reset when the stage resets. However, by means of switches SGF3/1...4 the starting indicators can be made latching, which means that they must be manually reset.

The numbers indicating starting and tripping are explained in the following table.

Indication	Explanation
1	I> start = The low-set stage of the overcurrent unit has started.
2	I> trip = The low-set stage of the overcurrent unit has operated.
3	I>> start = The high-set stage of the overcurrent unit has started.
4	I>> trip = The high-set stage of the overcurrent unit has operated.
5	U ₀ > start = The residual voltage stage has started.
6	I ₀₁ > start = The low-set stage of the earth-fault unit has started.
7	I ₀₁ > trip = The low-set stage of the earth-fault unit has operated.
8	I ₀₂ > trip = The high-set stage of the earth-fault unit has operated.
9	CBFP = The circuit breaker failure protection has operated.

The self supervision alarm indicator IRF indicates that the self-supervision system has detected a permanent fault. The indicator goes on with red light about 1 minute after the fault has been detected. At the same time the plug-in module delivers a signal to the self-supervision system output relay of the protection assembly.

Additionally, in most cases, a fault code showing the nature of the fault appears on the display of the module. The fault code consists of a red figure one and a green code number. When a fault occurs, the fault code should be recorded and stated when service is ordered.

Relay settings

The setting values are shown by the right-most three digits of the display. An indicator close to the setting value symbol shows when illumi-

nated which setting value is presented on the display at the very moment.

Setting	Parameter	Setting range
I> [I _n]	The starting current of the low-set stage of the overcurrent unit as a multiple of the rated current I _n of the selected energizing input. - at definite time characteristic - at inverse time characteristic Note! At inverse time characteristic any setting above 2.5 x I _n will be regarded as being equal to 2.5 x I _n .	0.5...5.0 x I _n 0.5...2.5 x I _n
t> [s]	The operation time of the I> stage, expressed in seconds, when the low-set stage of the overcurrent unit is operating with definite time characteristic (SGF1/1,2,3=0).	0.05...300 s
k	The time multiplier k1, when the low-set stage of the overcurrent unit is operating with inverse definite minimum time characteristic.	0.05...1.00
I>> [I _n]	The starting current of the high-set stage of the overcurrent unit as a multiple of the rated current of the selected energizing input. Additionally, the setting "infinite" (displayed as - - -) can be selected with switch SGF1/7, which takes the high-set stage I>> out of operation.	0.5...40.0 x I _n
t>> [s]	The operation time of the high-set stage I>> of the overcurrent unit, expressed in seconds.	0.04...300 s
U ₀ > [%]	The starting voltage of the residual voltage stage U ₀ as a percentage of the rated voltage of the selected energizing input.	2.0...80.0% U _n
I ₀₁ > [%]	The starting current of the low-set stage I ₀₁ > of the earth-fault unit as a percentage of the rated current of the selected energizing input.	1.0...25.0% I _n
t ₀₁ > [s]	The operation time t ₀₁ > of the low-set stage I ₀₁ > of the earth-fault unit, expressed in seconds.	0.1...300 s
I ₀₂ > [%]	The starting current I ₀₂ > of the high-set stage as a percentage of the rated current of the selected energizing input. Additionally, the setting "infinite" (displayed as - - -) can be selected, with switch SGF1/8, which takes the high-set stage of the earth-fault unit out of operation.	2.0...150% I _n
t ₀₂ > [s]	se Appendix 2	0.1...2.5 s

Further the checksums of the selector switchgroups SGF1, SGB1, and SGR1 are indicated on the display when the indicators adjacent to the switchgroup symbols on the front panel are lit. The checksums for the switchgroups SGF2, SGF3, SGB2, SGB3, SGR2 and SGR3 are

found in the submenus of the corresponding main switchgroups. Further, see clause "Main menus and submenus of settings and registers". An example of calculating the checksum is given in the general description of the D-type SPC relay modules.

Function selector switches

Additional functions required by individual applications are selected by using the switchgroups SGF, SGB and SGR indicated on the front panel. The numbering of the switches, i.e. 1...8, the switch positions, i.e. 0 and 1, are indicated on the display when the switches are

set. Under normal service only the checksums are shown. The switchgroups SGF2, SGF3, SGB2, SGB3, SGR2 and SGR3 are found in the submenus of the main switchgroups SGB, SGF and SGR.

Functional switchgroups SGF1, SGF2 and SGF3

Switch	Function	Default setting																																													
SGF1/1 SGF1/2 SGF1/3	<p>Switches SGF1/1...3 are used for selecting the operation characteristic of the low-set stage I>, i.e. definite time characteristic or inverse definite minimum time (I.D.M.T.) characteristic. Further, at inverse definite minimum time characteristic the switches are used for selecting the required current/time characteristic of the stage.</p> <table border="1"> <thead> <tr> <th>SGF1/1</th> <th>SGF1/2</th> <th>SGF1/3</th> <th>Characteristic</th> <th>Time or curve</th> </tr> </thead> <tbody> <tr> <td>0</td> <td>0</td> <td>0</td> <td>Definite time</td> <td>0.05...300 s</td> </tr> <tr> <td>1</td> <td>0</td> <td>0</td> <td>I.D.M.T.</td> <td>Extremely inv.</td> </tr> <tr> <td>0</td> <td>1</td> <td>0</td> <td>"</td> <td>Very inverse</td> </tr> <tr> <td>1</td> <td>1</td> <td>0</td> <td>"</td> <td>Normal inverse</td> </tr> <tr> <td>0</td> <td>0</td> <td>1</td> <td>"</td> <td>Long-time inv.</td> </tr> <tr> <td>1</td> <td>0</td> <td>1</td> <td>"</td> <td>RI-character.</td> </tr> <tr> <td>0</td> <td>1</td> <td>1</td> <td>"</td> <td>RXIDG-character.</td> </tr> <tr> <td>1</td> <td>1</td> <td>1</td> <td>"</td> <td>Long-time inv.</td> </tr> </tbody> </table>	SGF1/1	SGF1/2	SGF1/3	Characteristic	Time or curve	0	0	0	Definite time	0.05...300 s	1	0	0	I.D.M.T.	Extremely inv.	0	1	0	"	Very inverse	1	1	0	"	Normal inverse	0	0	1	"	Long-time inv.	1	0	1	"	RI-character.	0	1	1	"	RXIDG-character.	1	1	1	"	Long-time inv.	0 0 0
SGF1/1	SGF1/2	SGF1/3	Characteristic	Time or curve																																											
0	0	0	Definite time	0.05...300 s																																											
1	0	0	I.D.M.T.	Extremely inv.																																											
0	1	0	"	Very inverse																																											
1	1	0	"	Normal inverse																																											
0	0	1	"	Long-time inv.																																											
1	0	1	"	RI-character.																																											
0	1	1	"	RXIDG-character.																																											
1	1	1	"	Long-time inv.																																											
SGF1/4	<p>Selection /deselection of the circuit breaker failure protection.</p> <p>When SGF1/4=1 the tripping signal TS2 starts a timer which, via TS1, provides a tripping signal after a set time, if the fault still persists. When switch SGF1/4=0 only the normal tripping signal is provided.</p>	0																																													
SGF1/5	<p>Selection of automatic doubling of the set starting value of the high-set stage I>> when the protected object is energized.</p> <p>When SGF1/5=0, no doubling of the setting value I>> is obtained. When SGF1/5=1, the setting value of the I>> stage doubles automatically. This makes it possible to give the high-set stage a setting value below the connection inrush current level of the protected object.</p>	0																																													
SGF1/6	<p>Inhibition of the operation of the first earth-fault stage I₀₁> by the starting signal of the low-set overcurrent stage I>.</p> <p>When SGF1/6=0, the e/f stage I₀₁> is not inhibited by the starting signal of the low-set stage I>.</p> <p>When SGF1/6=1, the e/f stage I₀₁> is inhibited by the starting signal of the low-set stage I>.</p>	0																																													
SGF1/7	<p>Selection/deselection of the high-set stage I>> of the overcurrent unit.</p> <p>When SGF1/7=0, the high-set stage is alert.</p> <p>When SGF1/7=1, the high-set stage is out of operation.</p>	0																																													
SGF1/8	<p>Selection/deselection of the high-set stage I₀₂> of the earth-fault unit.</p> <p>When SGF1/8=0, the high-set stage is alert.</p> <p>When SGF1/8=1, the high-set stage is out of operation.</p>	0																																													

Switch	Function	Default setting															
SGF2/1 SGF2/2	<p>Selection of the base angle. The operation area of the protection is the basic angle $\varphi_b \pm$ the operation sector.</p> <table border="1"> <thead> <tr> <th>SGF2/1</th> <th>SGF2/2</th> <th>Basic angle</th> </tr> </thead> <tbody> <tr> <td>0</td> <td>0</td> <td>-90°</td> </tr> <tr> <td>1</td> <td>0</td> <td>-60°</td> </tr> <tr> <td>0</td> <td>1</td> <td>-30°</td> </tr> <tr> <td>1</td> <td>1</td> <td>0°</td> </tr> </tbody> </table>	SGF2/1	SGF2/2	Basic angle	0	0	-90°	1	0	-60°	0	1	-30°	1	1	0°	0 0
SGF2/1	SGF2/2	Basic angle															
0	0	-90°															
1	0	-60°															
0	1	-30°															
1	1	0°															
SGF2/3	<p>Selection of operation direction for the low-set earth-fault stage $I_{01}>$.</p> <p>When SGF2/3=0, the low-set stage $I_{01}>$ operates in the forward direction, as defined in the connection diagram. When SGF2/3=1, the low-set stage $I_{01}>$ operates in the reverse direction, as defined in the connection diagram.</p>	0															
SGF2/4	<p>Selection of directional operation characteristic for the low-set earth-fault stage or residual overvoltage function without current criterion.</p> <p>When SGF2/4=0, the low-set stage of the earth-fault unit operates with directional characteristic including current measurement. When SGF2/4=1, the low-set stage of the earth-fault unit functions as a residual overvoltage unit with the operation time $t_{01}>$.</p>	0															
SGF2/5	<p>Selection of operation direction for the high-set stage $I_{02}>$ of the earth-fault unit.</p> <p>When SGF2/5=0, the high-set stage $I_{02}>$ operates in the forward direction, as defined in the connection diagram. When SGF2/5=1, the low-set stage $I_{02}>$ operates in the reverse direction, as defined in the connection diagram.</p>	0															
SGF2/6	<p>Selection of directional or non-directional operation for the high-set earth-fault stage $I_{02}>$.</p> <p>When SGF2/6=0, the operation characteristic of high-set stage $I_{02}>$ is directional. When SGF2/6=1, the operation characteristic of high-set stage $I_{02}>$ is non-directional.</p>	0															
SGF2/7	<p>Routing of the starting signal from the high-set stage of the overcurrent unit to the output AR1.</p> <p>When SGF2/7=0, no starting signal from the high-set stage $I>>$ is routed to the output AR1. When SGF2/7=1, the starting signal from the high-set stage $I>>$ is routed to the output AR1.</p>	0															
SGF2/8	<p>Routing of the starting signal from the stage $I_{01}>$ or the stage $U_0>$ to the output AR3.</p> <p>When SGF2/8=0, the starting signal from the low-set stage $I_{01}>$ is routed to the output AR3. When SGF2/8=1, the starting signal from the residual overvoltage stage $U_0>$ is routed to the output signal AR3.</p>	0															

Switch	Function	Default setting
SGF3/1 SGF3/2 SGF3/3 SGF3/4	<p>Switches SGF3/1...4 are used for selecting the mode of operation of the starting indicators of the different stages. When the switches are in position 0, the starting indicators are automatically reset when the fault is cleared. In order to get a manually reset starting indication for a stage, the corresponding switch is set into position 1:</p> <p>When SGF3/1=1, the starting indicator of the low-set overcurrent stage $I_{>}$ is to be manually reset. When SGF3/2=1, the starting indicator of the high-set overcurrent stage $I_{>>}$ is to be manually reset. When SGF3/3=1, the starting indicator of the residual overvoltage stage $U_{0>}$ is to be manually reset. When SGF3/4=1, the starting indicator of the low-set earth-fault stage $I_{01>}$ is to be manually reset.</p>	0 0 0 0
SGF3/5	<p>Selection of operation sector for the directional earth-fault protection unit.</p> <p>When SGF3/5=0, the operation sector is $\pm 80^\circ$. When SGF3/5=1, the operation sector is $\pm 88^\circ$.</p>	0
SGF3/6	<p>Selection of operation principle for earth-fault stage $I_{02>}$ *)</p> <p>SGF3/6=0 normal earth-fault stage SGF3/6=1 detection of intermittent earth faults</p> <p>*) <i>This switch is available in version SW 089 C</i></p>	0
SGF3/7	SGF3/7 Available in program version SW 089 F, p. 40, appendix 2	0
SGF3/8	Not in use	0

Note!

Switchgroup SGX/1...6 is available in program version SW 089 F, see page 40 in Appendix 2.

Switch	Function	Default setting
SGB1/1 SGB1/2 SGB1/3 SGB1/4	<p>Switches SGB1/1...4 are used when the external control signal BS1 is to be used for blocking of the operation stages of the module one by one. When all the switches are in position 0 no stage is blocked.</p> <p>When SGB1/1=1, the operation of low-set overcurrent stage I> is blocked by the control signal BS1. When SGB1/2=1, the operation of high-set overcurrent stage I>> is blocked by the control signal BS1. When SGB1/3=1, the operation of the low-set earth-fault stage I₀₁> is blocked by the control signal BS1. When SGB1/4=1, the operation of the high-set earth-fault stage I₀₂> is blocked by the control signal BS1.</p>	0 0 0 0
SGB1/5	<p>Selection of main setting values or second setting values using an external control signal.</p> <p>When SGB1/5 = 0, the main or second setting values are determined according to the actual setting, that is, the setting is selected via command V150 over the serial interface or manually with the pushbuttons. When SGB1/5 = 1, an external control signal is used for selecting main setting or second setting values. The main settings are active, when no control voltage is applied to the control input BS1, whereas the second settings are active, when a control voltage is applied to the control input.</p> <p><i>Note! When SGB1/5 is in position 1, the relay module does not accept main settings or second settings made over the serial interface or via the pushbuttons on the front panel.</i> <i>Note! Only one of the switches SGB1...3/5 is allowed to be in position 1.</i> <i>Note! Switch SGB1/5 must always be in the same position in the main settings and the second settings.</i></p>	0
SGB1/6	<p>Selection of latching function for the output signal TS2 after being activated by the overcurrent unit.</p> <p>When SGB1/6=0, the operation signal of the I> stage and the I>> stage resets when the corresponding stage resets. When SGB1/6=1, the operation signal of the I> stage and the I>> stage must be manually reset by pressing the RESET and PROGRAM push-buttons simultaneously. The TS2 signal can also be reset by signal BS1. Note switch SGB1/8. When the display is off the signals can also be reset by pressing the PROGRAM push-button alone.</p>	0
SGB1/7	<p>Selection of latching function for the output signal TS2 after activated by the earth-fault unit.</p> <p>When SGB1/7=0, the operation signal of the I₀₁> stage and the I₀₂>> stage resets when the corresponding stage resets. When SGB1/7=1, the operation signal of the I₀₁> stage and the I₀₂>> stage must be manually reset by pressing the RESET and PROGRAM push-buttons simultaneously. The TS2 signal can also be reset by signal BS1. Note switch SGB1/8. When the display is off the signals can also be reset by pressing the PROGRAM push-button alone.</p>	0
SGB1/8	<p>Complete remote relay reset, including operation indicators, latched output relays and recorded values.</p> <p>A remote relay reset can be performed using the external control signal BS1 when switch SGB1/8=1.</p>	

Switchgroup SGB2 for configuring the control signal BS2

Switch	Function	Default setting
SGB2/1 SGB2/2 SGB2/3 SGB2/4	<p>Switches SGB2/1...4 are used when the external control signal BS2 is to be used for blocking the operation stages of the module one by one. When all the switches are in position 0 no stage is blocked.</p> <p>When SGB2/1=1, the operation of low-set overcurrent stage I> is blocked by the control signal BS2. When SGB2/2=1, the operation of high-set overcurrent stage I>> is blocked by the control signal BS2. When SGB2/3=1, the operation of the low-set earth-fault stage I₀₁> is blocked by the control signal BS2. When SGB2/4=1, the operation of the high-set earth-fault stage I₀₂> is blocked by the control signal BS2.</p>	0 0 0 0
SGB2/5	<p>Selection of main setting values or second setting values using an external control signal.</p> <p>When SGB2/5 = 0, the main or second setting values are determined according to the actual setting, that is, the setting is selected via command V150 over the serial interface or manually with the pushbuttons. When SGB2/5 = 1, an external control signal is used for selecting main setting or second setting values. The main settings are active, when no control voltage is applied to the control input BS2, whereas the second settings are active, when a control voltage is applied to the control input.</p> <p><i>Note! When SGB2/5 is in position 1, the relay module does not accept main settings or second settings made over the serial interface or via the pushbuttons on the front panel.</i> <i>Note! Only one of the switches SGB1...3/5 is allowed to be in position 1.</i> <i>Note! Switch SGB2/5 must always be in the same position in the main settings and the second settings.</i></p>	0
SGB2/6	<p>Remote resetting of the operation indicators by means of the external control signal BS2.</p> <p>When SGB2/6=0, the operation indicators are not reset by means of BS2. When SGB2/6=1, the operation indicators are reset by means of BS2.</p>	0
SGB2/7	<p>Remote resetting of the operation indicators and the output relays by means of the external control signal BS2.</p> <p>When SGB2/7=0, the operation indicators and the output relays are not reset by means of BS2. When SGB2/7=1, the operation indicators and the output relays are reset by means of BS2.</p>	0
SGB2/8	<p>Complete remote relay reset, including operation indicators, latched output relays and recorded values.</p> <p>A remote relay reset can be performed using the external control signal BS2 when switch SGB2/8=1.</p>	0

Switchgroup SGB3 for configuring the control signal RRES

Switch	Function	Default setting
SGB3/1 SGB3/2 SGB3/3 SGB3/4	<p>Switches SGB3/1...4 are used when the external control signal RRES is to be used for blocking the operation stages of the module one by one. When all the switches are in position 0 no stage is blocked.</p> <p>When SGB3/1=1, the operation of low-set overcurrent stage I> is blocked by the control signal RRES. When SGB3/2=1, the operation of high-set overcurrent stage I>> is blocked by the control signal RRES. When SGB3/3=1, the operation of the low-set earth-fault stage I₀₁> is blocked by the control signal RRES. When SGB3/4=1, the operation of the high-set earth-fault stage I₀₂> is blocked by the control signal RRES.</p>	0 0 0 0
SGB3/5	<p>Selection of main setting values or second setting values using an external control signal.</p> <p>When SGB3/5 = 0, the main or second setting values are determined according to the actual setting, that is, the setting is selected via command V150 over the serial interface or manually with the pushbuttons. When SGB3/5 = 1, an external control signal is used for selecting main setting or second setting values. The main settings are active, when no control voltage is applied to the control input RRES, whereas the second settings are active, when a control voltage is applied to the control input.</p> <p><i>Note! When SGB3/5 is in position 1, the relay module does not accept main settings or second settings made over the serial interface or via the pushbuttons on the front panel.</i> <i>Note! Only one of the switches SGB1...3/5 is allowed to be in position 1.</i> <i>Note! Switch SGB3/5 must always be in the same position in the main settings and the second settings.</i></p>	0
SGB3/6	<p>Remote resetting of the operation indicators by means of the external control signal RRES.</p> <p>When SGB3/6=0, the operation indicators are not reset by means of RRES. When SGB3/6=1, the operation indicators are reset by means of RRES.</p>	0
SGB3/7	<p>Remote resetting of the operation indicators and the output relays by means of the external control signal RRES.</p> <p>When SGB3/7=0, the operation indicators and the output relays are not reset by means of RRES. When SGB3/7=1, the operation indicators and the output relays are reset by means of RRES.</p>	0
SGB3/8	<p>Complete remote relay reset, including operation indicators, latched output relays and recorded values.</p> <p>A remote relay reset can be performed using the external control signal RRES when switch SGB3/8=1.</p>	0

Output relay matrix
switchgroups SGR1,
SGR2 and SGR3

Switch	Function	Default setting
SGR1/1	When SGR1/1=1 the starting signal of stage I> is linked to SS1 + AR2.	1
SGR1/2	When SGR1/2=1 the tripping signal of stage I> is linked to TS2.	1
SGR1/3	When SGR1/3=1 the starting signal of stage I>> is linked to SS1 + AR2.	0
SGR1/4	When SGR1/4=1 the tripping signal of stage I>> is linked to TS2.	1
SGR1/5	When SGR1/5=1 the starting signal of stage I ₀₁ > is linked to SS1 + AR2.	0
SGR1/6	When SGR1/6=1 the tripping signal of stage I ₀₁ > is linked to TS2.	1
SGR1/7	When SGR1/7=1 the starting signal of stage U ₀ > is linked to SS1 + AR2.	0
SGR1/8	When SGR1/8=1 the tripping signal of stage I ₀₂ > is linked to TS2.	1

SGR2/1	When SGR2/1=1 the tripping signal of stage I> is linked to SS2.	1
SGR2/2	When SGR2/2=1 the tripping signal of stage I> is linked to SS3 + AR1.	0
SGR2/3	When SGR2/3=1 the tripping signal of stage I>> is linked to SS2.	1
SGR2/4	When SGR2/4=1 the tripping signal of stage I>> is linked to SS3 + AR1.	0
SGR2/5	When SGR2/5=1 the tripping signal of stage I ₀₁ > is linked to SS2.	0
SGR2/6	When SGR2/6=1 the tripping signal of stage I ₀₁ > is linked to SS3 + AR1.	1
SGR2/7	When SGR2/7=1 the tripping signal of stage I ₀₂ > is linked to SS2.	0
SGR2/8	When SGR2/8=1 the tripping signal of stage I ₀₂ > is linked to SS3 + AR1.	1

SGR3/1	When SGR3/1=1 the starting signal of stage I> is linked to TS1.	0
SGR3/2	When SGR3/2=1 the tripping signal of stage I> is linked to TS1.	0
SGR3/3	When SGR3/3=1 the starting signal of stage I>> is linked to TS1.	0
SGR3/4	When SGR3/4=1 the tripping signal of stage I>> is linked to TS1.	0
SGR3/5	When SGR3/5=1 the starting signal of stage I ₀₁ > is linked to TS1.	0
SGR3/6	When SGR3/6=1 the tripping signal of stage I ₀₁ > is linked to TS1.	0
SGR3/7	When SGR3/7=1 the starting signal of stage U ₀ > is linked to TS1.	0
SGR3/8	When SGR3/8=1 the tripping signal of stage I ₀₂ > is linked to TS1.	0

Measured data

The measured values are displayed by the three right-most digits of the display. The currently displayed value is indicated by an illuminated LED indicator on the front panel.

Indicator	Measured value
I _{L1}	Current on phase L1 as a multiple of the rated current I _n of the input used.
I _{L3}	Current on phase L1 as a multiple of the rated current I _n of the input used.
U ₀	Residual voltage as a percentage of the rated voltage U _n of the input used.
I ₀	Neutral current as a percentage of the rated current I _n of the input used.
I ₀ (φ)	In the submenu of the neutral current the phase angle between residual voltage U ₀ and neutral current I ₀ is available. The phase angle value φ is the difference between the set basic angle φ _b and measured neutral current value I ₀ , -180°...0...+180°. <i>Note! The phase angle φ cannot be measured unless the input signals (I₀ and U₀) are at least 1%. Otherwise the display shows "- - -".</i>

Recorded data

The left-most red digit displays the register address and the other three digits the recorded information. A symbol "/" in the text indicates that the item following is found in a submenu.

Register	Recorded information
1	Maximum demand current value for a period of 15 minutes expressed as a multiple of the relay rated current I_n and based on the highest phase current. // Highest maximum demand value found since the latest complete relay reset.
2	Phase current I_{L1} measured as a multiple of the rated current of the protection. If the overcurrent unit starts but does not operate, the highest value during the starting situation is recorded and if the unit operates the value at the moment of operation is recorded in a memory stack. A new starting or operation moves the old value up one place in the stack and adds a new value to the stack. At a maximum five values are recorded. If a sixth starting or operation occurs, the oldest recorded value will be lost.
3	Phase current I_{L3} measured as a multiple of the rated current of the protection. If the overcurrent unit starts but does not operate, the highest value during the starting situation is recorded and if the unit operates the value at the moment of operation is recorded in a memory stack. A new starting or operation moves the old value up one place in the stack and adds a new value to the stack. At a maximum five values are recorded. If a sixth starting or operation occurs, the oldest recorded value will be lost.
4	Duration of the latest starting situation of stage I> as a percentage of the set operation time $t_{1>}$ or at IDMT mode of operation the calculated operation time. A new starting resets the counter, which then starts counting from zero, and moves the old value up in the memory stack. At a maximum five values are memorized. If a sixth starting occurs the oldest value will be lost. When the concerned stage has tripped the counter reading is 100. // Number of startings of the stage I> in the range 0...255.
5	Duration of the latest starting situation of stage I>> as a percentage of the set operation time $t_{>>}$ or at IDMT mode of operation the calculated operation time. A new starting resets the counter, which then starts counting from zero, and moves the old value up in the memory stack. At a maximum five values are memorized. If a sixth starting occurs the oldest value will be lost. When the concerned stage has tripped the counter reading is 100. // Number of startings of the stage I>> in the range 0...255.
6	Measured residual voltage U_0 during the latest starting situation as a percentage of the rated voltage of the protection. If the earth fault unit operates the residual voltage value at the moment of tripping is stored in a memory stack. A new tripping moves the old value up one place in the stack and adds a new value to the stack. At a maximum five values are memorized. If a sixth tripping occurs, the oldest value will be lost.
7	Measured neutral current I_0 during the latest starting situation as a percentage of the rated current of the protection. If the earth fault unit operates the current value at the moment of tripping is stored in a memory stack. A new tripping moves the old value up one place in the stack and adds a new value to the stack. At a maximum five values are recorded. If a sixth operation occurs, the oldest value will be lost.
8	Duration of the latest starting situation of stage $I_{01>}$ as a percentage of the set operation time $t_{1>}$. A new starting resets the counter, which then starts counting from zero, and moves the old value up in the memory stack. At a maximum five values are recorded. If a sixth starting occurs the oldest value will be lost. When the concerned stage has tripped the counter reading is 100. // Number of startings of the stage $I_{01>}$ in the range 0...255.

Register	Recorded information								
9	Duration of the latest starting situation of stage I_{02} as a percentage of the fixed operation time. A new starting resets the counter, which then starts counting from zero, and moves the old value up in the memory stack. At a maximum five values are memorized. If a sixth starting occurs the oldest value will be lost. When the concerned stage has tripped the counter reading is 100. // Number of startings of the stage I_{02} in the range 0...255.								
11	Phase angle φ between the basic angle φ_b and the neutral current I_0 . When the earth-fault unit operates, the phase angle φ at the moment of operation is recorded in a memory stack. A new operation moves the old value up one place in the stack and adds a new value to the stack. At a maximum five values are recorded. If a sixth operation occurs, the oldest recorded value will be lost.								
0	Display of external blocking and control signals. The right-most digit indicates the state of the blockings input of the unit. Each input signals is represented by a number and the displayed number is the sum of the numbers representing the inputs which are energized. The following numbers represent the inputs: <table style="width: 100%; border: none;"> <tr> <td style="width: 50%;">0 = no input energized</td> <td style="width: 50%;">1 = BS1 energized</td> </tr> <tr> <td>2 = BS2 energized</td> <td>3 = BS1 and BS2 energized</td> </tr> <tr> <td>4 = RRES energized</td> <td>5 = BS1 and RRES energized</td> </tr> <tr> <td>6 = BS2 and RRES energized</td> <td>7 = BS1, BS2 and RRES energized</td> </tr> </table> From this register "0" it is possible to move on to the TEST mode, where the starting and operation signals of the module are activated one by one. For further details see the description "General characteristics of D-type SPC relay modules".	0 = no input energized	1 = BS1 energized	2 = BS2 energized	3 = BS1 and BS2 energized	4 = RRES energized	5 = BS1 and RRES energized	6 = BS2 and RRES energized	7 = BS1, BS2 and RRES energized
0 = no input energized	1 = BS1 energized								
2 = BS2 energized	3 = BS1 and BS2 energized								
4 = RRES energized	5 = BS1 and RRES energized								
6 = BS2 and RRES energized	7 = BS1, BS2 and RRES energized								
A	Address code of the measuring relay module, required by the serial communication system. The submenus of this register include the following settings or functions. 1) Setting of serial communication data transfer rate: 4.8 or 9.6 kBd. Default setting 9.6 kBd. 2) Bus traffic monitor. If the relay module is connected to a data communication system and the communication operates properly, the monitor value is 0. Otherwise the numbers 0...255 are rolling. 3) Password required for the remote control of the settings. The password (SPA parameter V160) must always be entered before a setting can be changed over the serial bus. 4) Selection of main / second setting bank. (0 = main settings, 1 = second settings) 5) Setting of operate time for the circuit-breaker failure protection (CBFP). Setting range 0.1...1.0. Default setting 0.2 s 6) Programming switchgroup SGX. Detailed information on page 40, Appendix 2. Default setting 0.								

The registers 1...11 are set to zero by pressing the push-buttons RESET and PROGRAM simultaneously. The registers are also cleared if the auxiliary power supply to the module is interrupted. The address code of the plug-in module, the data transfer rate of the serial communica-

tion, the password, the selector status and the SBFP and SGX settings are not erased by a voltage failure. The instructions for setting the address and the data transfer are described in the manual "General characteristics of D-type SPC relay modules".

The measures required for entering a submenu or a setting mode and how to perform the setting and use the TEST mode are described in detail

on data sheet "General characteristics of the D-type relay modules". Below a short key to the operations:

Desired step or operation	Push-button	Action
Forward step in main or submenu	STEP	Press > 0.5 s
Rapid scan forward in main menu	STEP	Keep depressed
Reverse step in main or submenu	STEP	Press < 0.5 s
Entering a submenu from a main menu	PROGRAM	Press 1 s
Entering or leaving setting mode	PROGRAM	Press for 5 s
Increasing a value in setting mode	STEP	
Moving the cursor in setting mode	PROGRAM	Press about 1 s
Storing a value in setting mode	STEP & PROGRAM	Press simultaneously
Resetting of memorized values + latched output relays	STEP & PROGRAM	
Resetting of latched output relays	PROGRAM	Note! Display must be off

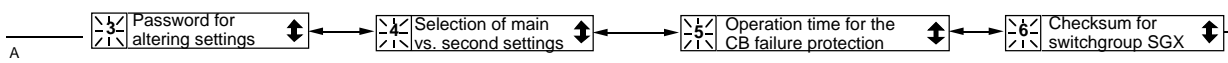
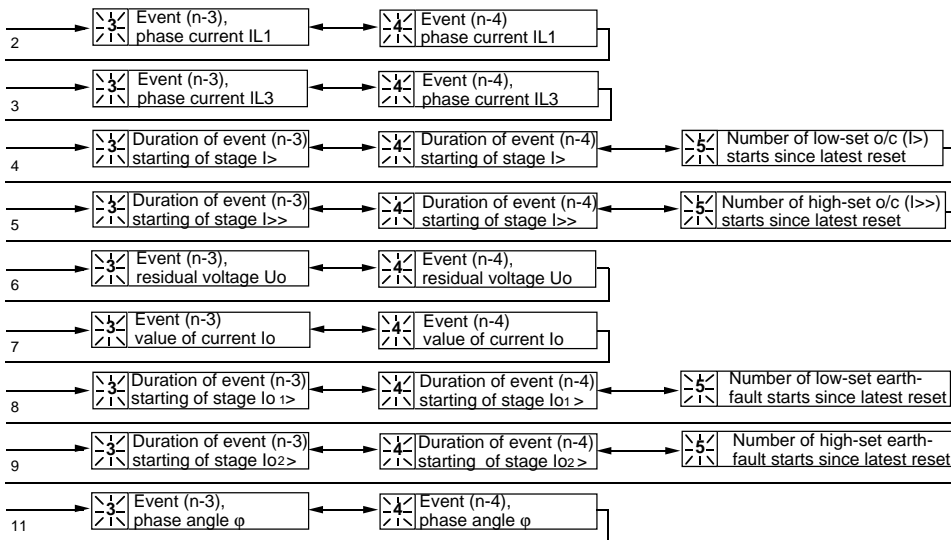
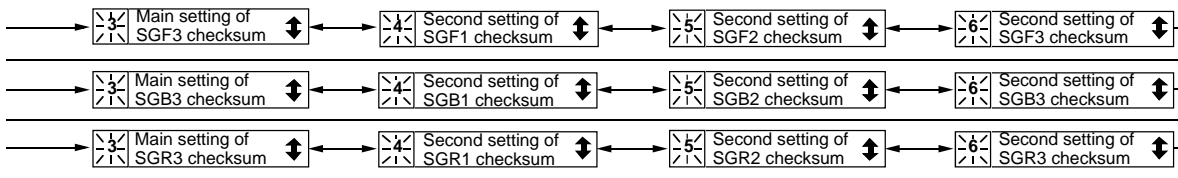

Time/current characteristics

The operation of the low-set overcurrent stage I> is based on either definite time or inverse time characteristics, as selected in the relay module. The desired characteristic for the overcurrent stage I> is selected with switches 1...3 of switch-group SGF1.

When an IDMT characteristic has been selected, the operation time of the stage will be a function of the current: the higher the current, the shorter the operation time. The relay module incorporates six different time/current characteristics - four according to BS and IEC and two special characteristics called RI and RXIDG.

BS type characteristic

Four standard characteristics are defined: extremely inverse, very inverse, normal inverse and long time inverse. The characteristics comply with the standards BS 142.1966 and IEC 60255-3 and can generally be expressed as:

$$t [s] = \frac{k \times \beta}{(I/I>)^{\alpha} - 1}$$

where:

t = operate time in seconds

k = time multiplier

I = measured phase current

I> = set start current

The relay module incorporates four BS 142 specified characteristics with different degrees of inversity. The degree of inversity is determined by the values of the constants α and β .

Characteristic (IDMT curves)	α	β
Normal inverse	0.02	0.14
Very inverse	1.0	13.5
Extremely inverse	2.0	80.0
Long time inverse	1.0	120.0

According to the standard BS 142.1966 the normal current range is defined as 2...20 times the setting current. Additionally the relay must start at the latest when the measured current exceeds 1.3 times the set starting value, when the time/current characteristic is normal inverse, very inverse or extremely inverse. When the characteristic is long time inverse, the normal range accordance to the standards is 2...7 times the set starting value and the relay must start when the current exceeds 1.1 times the set starting value.

The following requirements regarding tolerances of the operation time are specified in the standard (E denotes accuracy in per cent, - = not specified):

I/I>	Normal inverse	Very inverse	Extremely inv.	Long time inv.
2	2.22 E	2.34 E	2.44 E	2.34 E
5	1.13 E	1.26 E	1.48 E	1.26 E
7	-	-	-	1.00 E
10	1.01 E	1.01 E	1.02 E	-
20	1.00 E	1.00 E	1.00 E	-

The accuracy of the operation time of the IDMT curves of the low-set overcurrent stage of the relay module SPCJ 4D44 comply with the tolerances of class 5.

Note.

The actual operate time of the relay, presented in the graphs in Fig. 6...9, includes an additional filter and detection time plus the operate time of the trip output relay. When the operate time of the relay is calculated using the mathematical expression above, these additional times of about 30 ms in total have to be added to the time received.

RI-type characteristic

The RI type characteristic is a special characteristic used mainly for timegrading with existing mechanical relays. The characteristic is defined by the following mathematical expression:

$$t [s] = k / (0.339 - 0.236 \times I > / I)$$

where

t = operate time in seconds

k = time multiplier

I = measured phase current

I> = set start current

RXIDG-type characteristic

The RXIDG characteristic is a special characteristic where a high degree of selectivity is needed also for high-resistance faults. With this characteristic, the protection does not have to be directional and the scheme can operate without pilot communication.

The time/current characteristic can be expressed as:

$$t [s] = 5.8 - 1.35 \times \log_e(I/k \times I >)$$

where

t = operate time in seconds

k = time multiplier

I = measured phase current

I> = set start current

Note !

If the setting is higher than $2.5 \times I_n$, the maximum continuous carry $4 \times I_n$ and the levelling out of the IDMT curves at high current levels must be noted.

CAUTION !

Never use start current settings above $2.5 \times I_n$ at inverse time characteristic, although allowed by the relay.

Note !

The high-current end of any inverse time characteristic is determined by the high-set stage which, when started, inhibits the low-set stage operation. Thus, the trip time is equal to the set operate time $t_{>>}$ for any current higher than $I_{>>}$. In order to get a trip signal, the stage $I_{>>}$ must also, of course, be linked to a trip output relay.

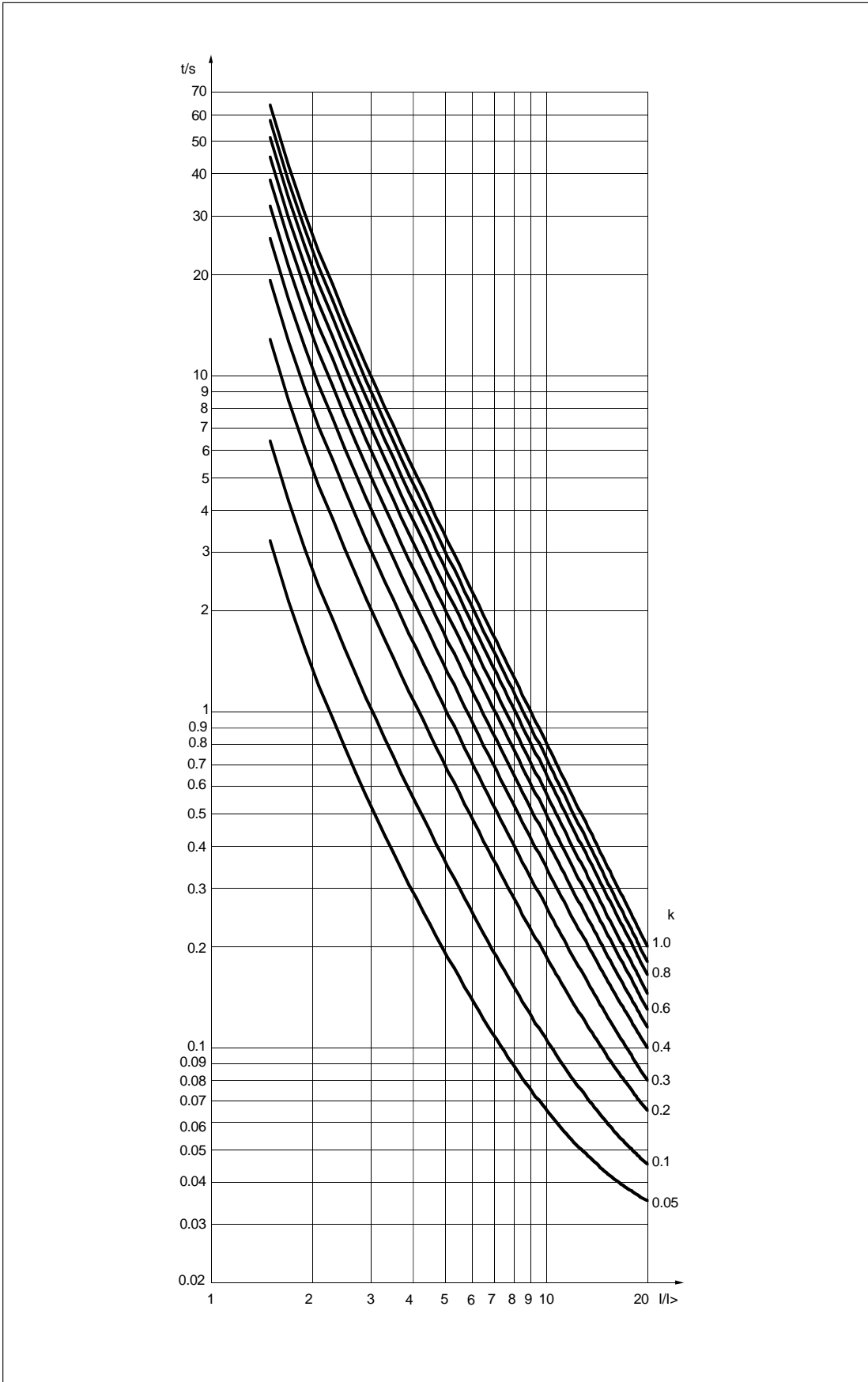

Fig 6. Extremely inverse-time characteristics of the two-phase overcurrent module SPCJ 4D44.

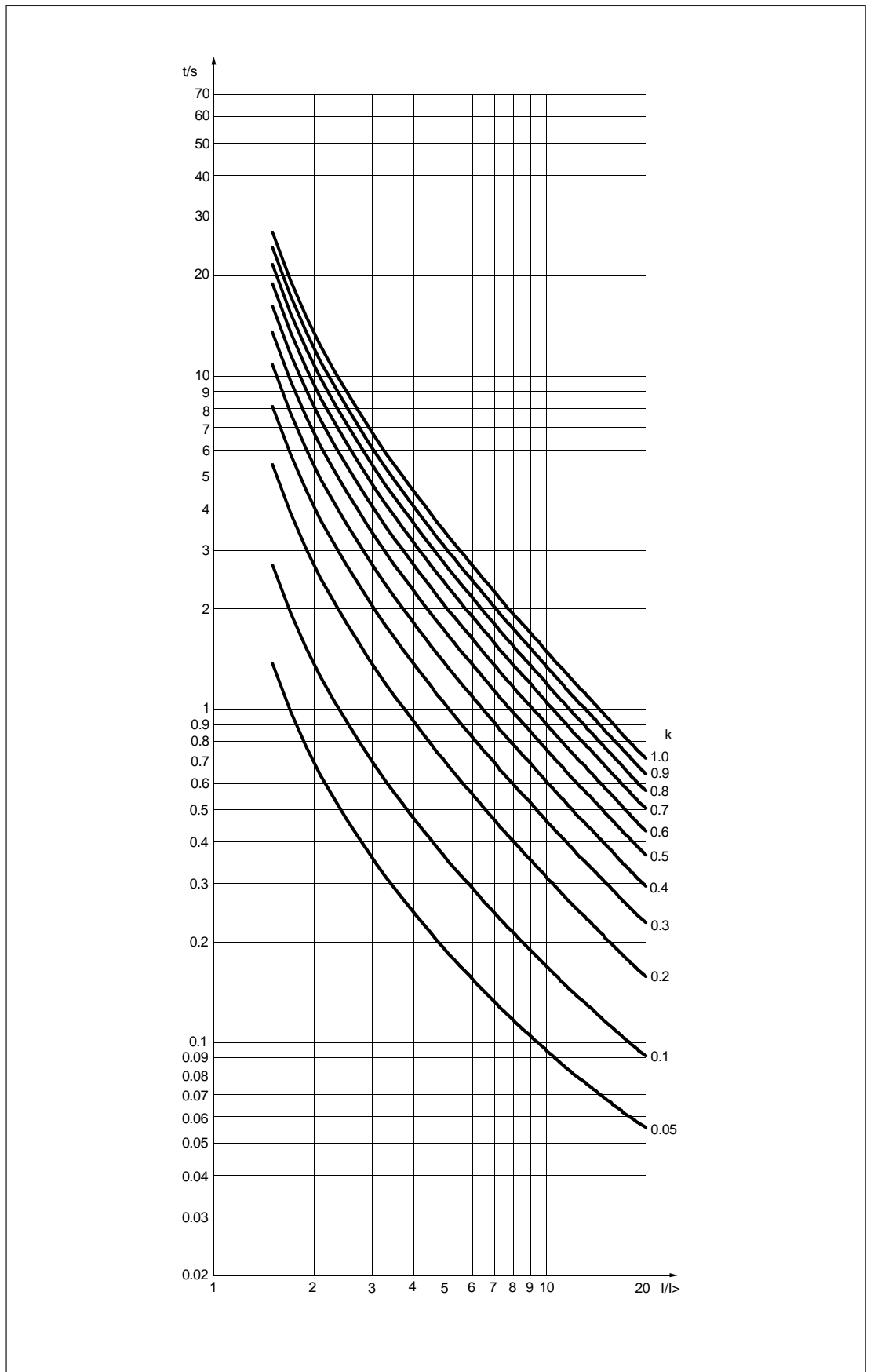

Fig 7. Very inverse-time characteristics of the two-phase overcurrent module SPCJ 4D44.

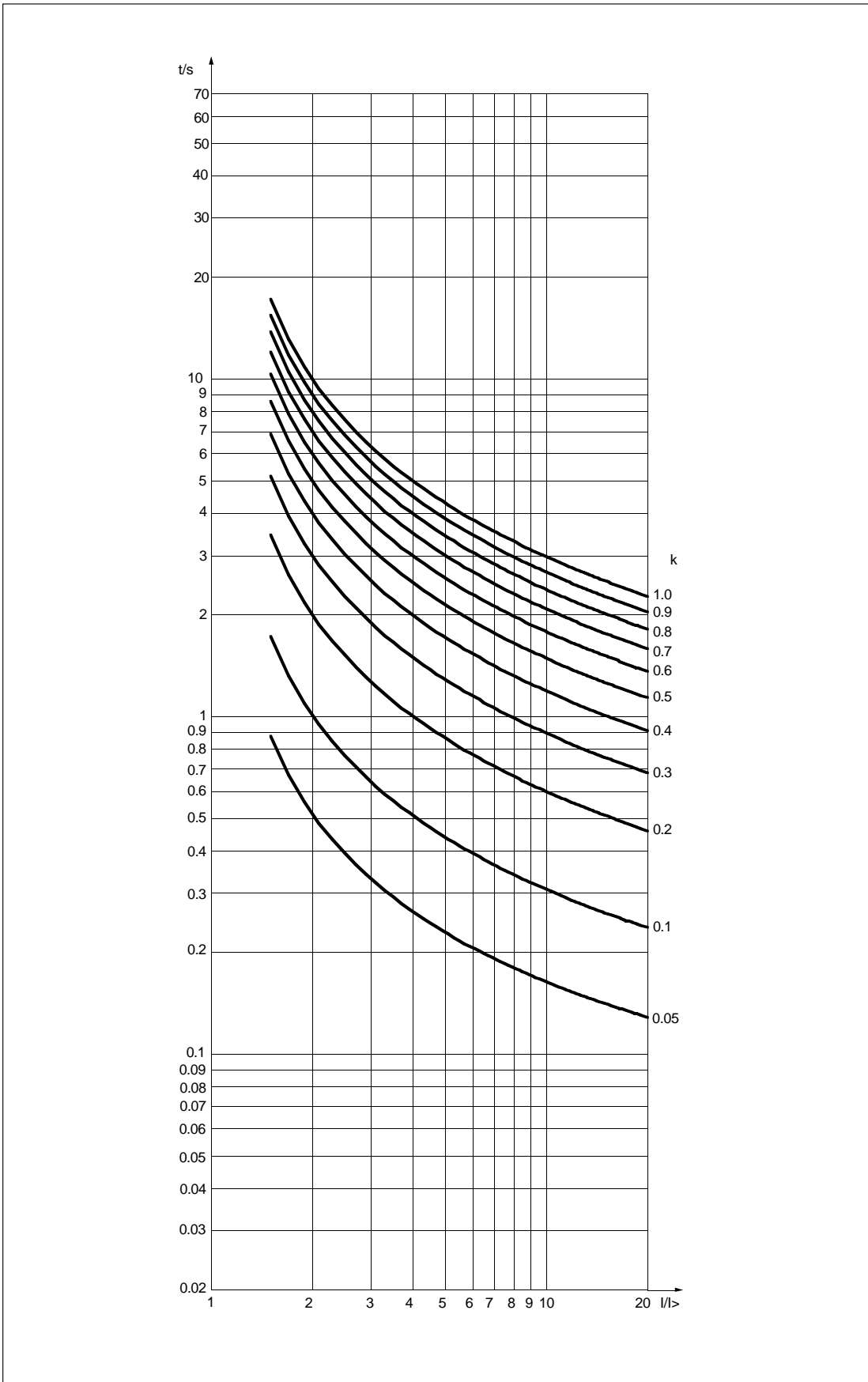

Fig 8. Normal inverse-time characteristics of the two-phase overcurrent module SPCJ 4D44.

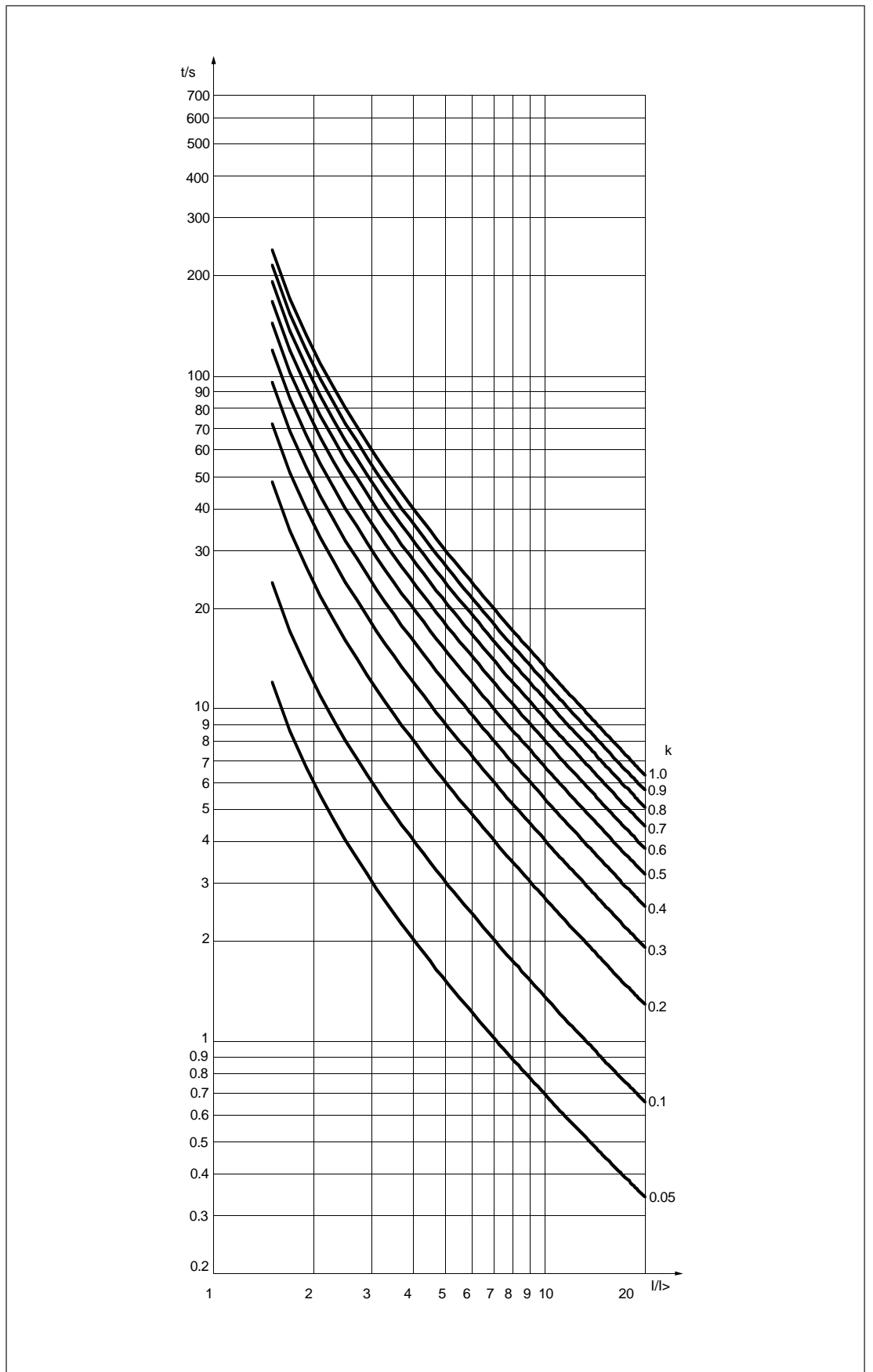

Fig 9. Long-time inverse-time characteristics of the two-phase overcurrent module SPCJ 4D44.

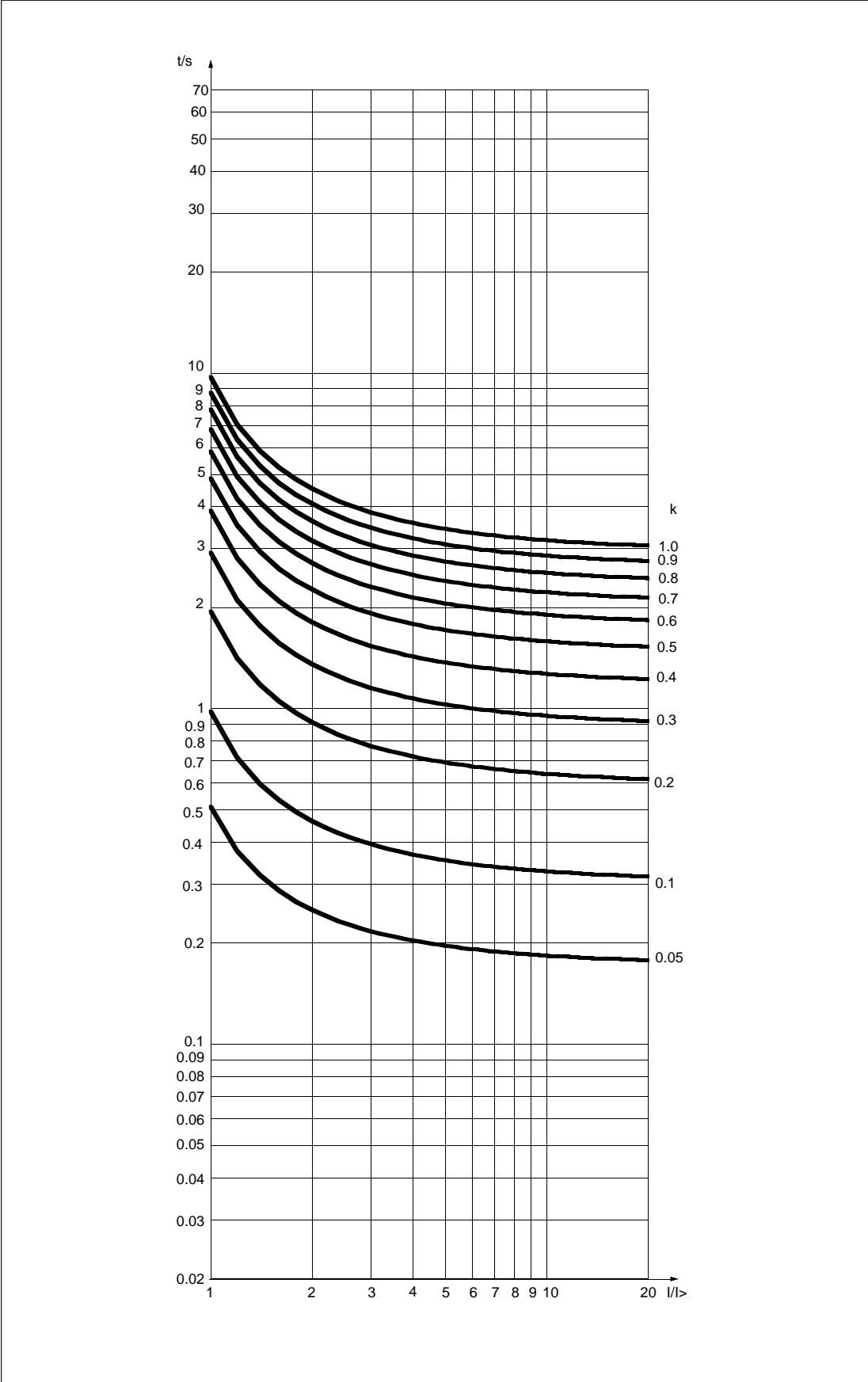

Fig 10. RI-type inverse-time characteristics of the two-phase overcurrent module SPCJ 4D44.

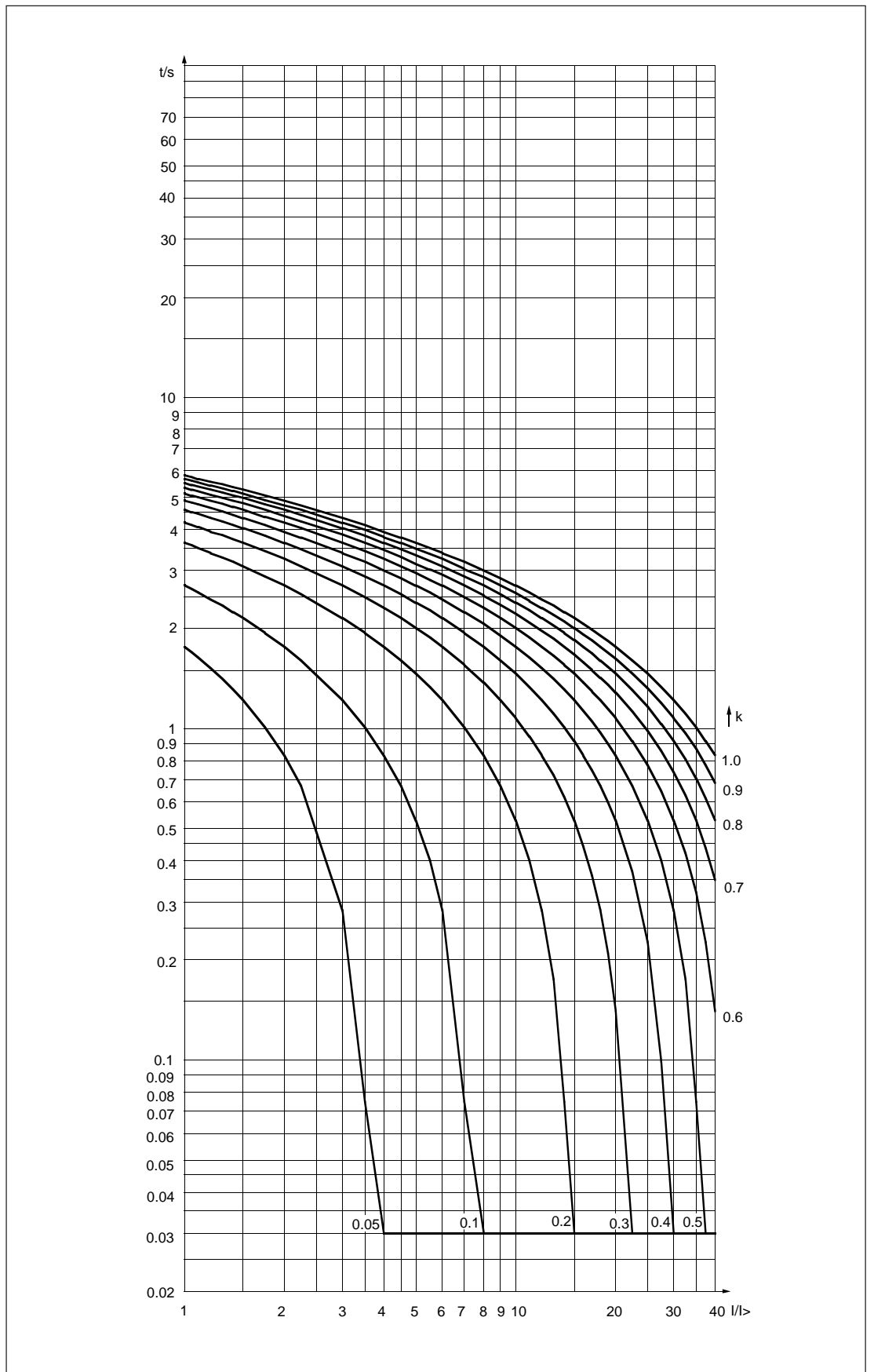

Fig 11. RXIDG-type inverse-time characteristics of the two-phase overcurrent module SPCJ 4D44.

Technical data

Overcurrent unit

Low-set stage I>	
Start current I>	
- at definite time	0.5...5.0 x I _n
- at inverse time	0.5...2.5 x I _n
Start time, typ.	60 ms
Operate time at definite time characteristic	0.05...300 s
Current/time curves at IDMT operation characteristic	Extremely inverse Very inverse Normal inverse Long time inverse RI type inverse RXIDG type inverse
Time multiplier k	0.05...1.00
Reset time, typ.	50 ms
Drop-off/pick-up ratio, typ.	0.96
Operate time accuracy at definite time operation characteristic	±2% of set value or ±25 ms
Operate time accuracy class E at inverse time operation characteristic	5
Operation accuracy	±3% of set value
High-set stage I>>	
Start current I>>	0.5...40.0 x I _n or ∞ , infinite
Start time, typ.	40 ms
Operate time, typ.	0.04...300 s
Reset time, typ.	50 ms
Drop-off/pick-up ratio, typ.	0.96
Operate time accuracy	±2% of set value or ±25 ms
Operation accuracy	±3% of set value

Note!

If the setting is higher than 2.5 x I_n, the maximum continuous carry 4 x I_n and the levelling out of the IDMT curves at high current levels must be noted.

CAUTION!

Never use start current settings above 2.5 x I_n at inverse time characteristic, although allowed by the relay.

Note!

The high-current end of any inverse time characteristic is determined by the high-set stage which, when started, inhibits the low-set stage operation. Thus, the trip time is equal to the set operate time t>> for any current higher than I>>. In order to get a trip signal, the stage I>> must also, of course, be linked to a trip output relay.

Earth-fault unit

Basic angle ϕ_b	0°, -30°, -60° or -90°
Operation sector $\Delta\phi$	$\pm 80^\circ$, $\pm 88^\circ$. Extended operation sector *)
Operation principle	Phase-angle measuring function. $I_0 \cos\phi$ function *)
Residual voltage stage $U_{0>}$	
Start voltage $U_{0>}$	2.0...80.0% U_n
Low-set stage $I_{01>}$	
Operation direction	Forward or reverse
Start current $I_{01>}$	1.0...25.0% I_n
Start time, typ.	100 ms
Operate time $t_{01>}$	0.1...300 s
Reset time, typ.	80 ms
Drop-off/pick-up ratio, typ.	0.96
Operate time accuracy	$\pm 2\%$ of set value or ± 25 ms
Operation accuracy	$\pm 3\%$ of set value + $0.0005 \times I_n$
High-set earth-fault stage $I_{02>}$	
Operation direction	Forward or reverse
Operation mode	Directional or non-directional
Start current $I_{02>}$	2.0...150% I_n or ∞ , infinite
Start time	100 ms or 750 ms
Operate time $t_{02>}$	100 ms or 750 ms. Extended operate time *)
Reset time	
-during start (SGF3/6=0), typ.	100 ms
-during start (SGF3/6=1), typ.	500 ms
-after tripping, typ.	100 ms
Internal reset time of intermittent operation	500 ms
Drop-off/pick-up ratio, typ.	0.96
Operate time accuracy	$\pm 2\%$ of set value or ± 25 ms **)
Operation accuracy	$\pm 3\%$ of set value + $0.0005 \times I_n$

*) See chapter "Technical data affected by versions SW 089 E, F", page 46.

**) When the detection of intermittent earth fault function has been selected for the $I_{02>}$ stage (SGF3/6=1) and the stage operates on intermittent earth faults with disruptive discharge pulses exceeding 100 ms, the operate time can be extended with that same time (max. 500 ms).

Event codes

When the combined two-phase overcurrent and directional earth-fault module SPCJ 4D44 is connected to a data communicator over the SPA bus, the module will generate event markings which can be printed out, for instance, on a printer or transmitted to higher system levels via the serial bus. The events are printed out in the format: time, text and event code. The event text is written by the user.

An event to be communicated, is marked with the multiplier 1. If the event is to be excluded the multiplier is 0. The event mask is formed by the sum of the weighting coefficients of all the events to be communicated.

The event masks V155 and V156 may have a

value within the range 0...255 while the event mask V157 may take a value within the range 0...1023. The parameters of the event masks are presented in the tables below. The default values of the event masks are calculated according to these tables.

The event codes E50...E54 and the events represented by these cannot be excluded from the event reporting. The event codes E52...E54 are generated by the data communicator used, e.g. SACO 100M, SRIO 1000M, etc.

Detailed information about the serial communication over the SPA bus is given in the document "SPA bus communication protocol", Document No. 34 SPACOM 2EN1.

Event mask	Code	Setting range	Default value
V155	E1...E8	0...255	85
V156	E9...E16	0...255	85
V157	E17...E26	0...1023	768

Code	Event	Weighting coefficient	Default setting
E1	Starting of stage I>	1	1
E2	Starting of stage I> reset	2	0
E3	Operation of stage I>	4	1
E4	Operation of stage I> reset	8	0
E5	Starting of stage I>>	16	1
E6	Starting of stage I>> reset	32	0
E7	Operation of stage I>>	64	1
E8	Operation of stage I>> reset	128	0
Default setting for event mask V155			85

E9	Starting of stage I ₀₁ >	1	1
E10	Starting of stage I ₀₁ > reset	2	0
E11	Operation of stage I ₀₁ >	4	1
E12	Operation of stage I ₀₁ > reset	8	0
E13	Starting of stage U ₀ >	16	1
E14	Starting of stage U ₀ > reset	32	0
E15	Operation of stage I ₀₂ >	64	1
E16	Operation of stage I ₀₂ > reset	128	0
Default setting for event mask V156			85

E17	Output signal TS1 activated	1	0
E18	Output signal TS1 reset	2	0
E19	Output signal SS1 activated	4	0
E20	Output signal SS1 reset	8	0
E21	Output signal SS2 activated	16	0
E22	Output signal SS2 reset	32	0
E23	Output signal SS3 activated	64	0
E24	Output signal SS3 reset	128	0
E25	Output signal TS2 activated	256	1
E26	Output signal TS2 reset	512	1
Default setting for event mask V157			768

E50	Restart of module	*	-
E51	Overflow of event register	*	-
E52	Temporary disturbance in data communication	*	-
E53	No response from the relay module over the data communication	*	-
E54	The relay module responds again over the data communication	*	-

- 0 Not included in the event reporting
- 1 included in the event reporting
- * No code number
- Cannot be set

Data to be transferred over the serial bus

In addition to the event data transfer the SPA bus allows reading of all input data (I-data), output data (O-data), setting values (S-data), information recorded in the memory (V-data), and some other data of the module. Further, part of the data can be altered by commands given over the SPA bus.

When setting values are altered via the MMI on the front panel or via the serial bus, the module checks that the entered parameter values are within the permitted setting range. The relay module refuses to accept a too high or a too low setting value, but keeps the old setting value unchanged.

Altering parameter values via the serial bus usually requires the use of a password. The password is a number within the range 1...999. The default password is 1.

The password is opened by writing the password number to parameter V160 and closed by writing the password number to parameter V161.

The password is also closed on loss of auxiliary supply to the relay module.

The password can be changed via the serial bus or via the MMI of the module. When the password is to be changed via the serial bus, the password must be opened first. The new password is written to parameter V161. The change of the password via the MMI of the module is carried out in register A, subregister 3, in which case the new password is written over the old one.

If an incorrect password is given seven times in a row via the serial bus, the password is automatically set to zero and after this it cannot be opened via the serial bus. Now the password can be opened only via the MMI of the module.

All the data are available in channel 0.

- MMI = Man-Machine Interface
- R = data to be read from the unit
- W = data to be written to the unit
- (P) = writing enabled by a password

Data	Code	Data direct.	Values
INPUTS			
Measured current on phase L1	I1	R	0...63 x I _n
Measured current on phase L3	I2	R	0...63 x I _n
Measured residual voltage U ₀	I3	R	0...106% U _n
Measured neutral current I ₀	I4	R	0...210% I _n
Phase angle φ between basic angle φ _b and I ₀	I5	R	-180°...0°...180°, 999 = signal too low to be measured
Blocking or control signal BS1	I6	R	0 = no blocking 1 = BS1 signal active
Blocking or control signal BS2	I7	R	0 = no blocking 1 = BS2 signal active
Blocking or control signal RRES	I8	R	0 = no blocking 1 = RRES signal active

Data	Code	Data direct.	Values
OUTPUTS			
Starting of stage I>	O1	R	0 = I> stage not started 1 = I> stage started
Tripping of stage I>	O2	R	0 = I> stage not tripped 1 = I> stage tripped
Starting of stage I>>	O3	R	0 = I>> stage not started 1 = I>> stage started
Tripping of stage I>>	O4	R	0 = I>> stage not tripped 1 = I>> stage tripped
Starting of stage I ₀₁ >	O5	R	0 = I ₀₁ > stage not started 1 = I ₀₁ > stage started
Tripping of stage I ₀₁ >	O6	R	0 = I ₀₁ > stage not tripped 1 = I ₀₁ > stage tripped
Starting of stage U ₀ >	O7	R	0 = U ₀ > stage not started 1 = U ₀ > stage started
Tripping of stage I ₀₂ >	O8	R	0 = I ₀₂ > stage not tripped 1 = I ₀₂ > stage tripped
Signal TS1	O9	R,W(P)	0 = signal not active 1 = signal active
Signal SS1	O10	R,W(P)	0 = signal not active 1 = signal active
Signal SS2	O11	R,W(P)	0 = signal not active 1 = signal active
Signal SS3	O12	R,W(P)	0 = signal not active 1 = signal active
Signal TS2	O13	R,W(P)	0 = signal not active 1 = signal active
Output relays	O41	R,W(P)	0 = not operated 1 = operated
Memorized starting of stage I>	O21	R	0 = signal not active 1 = signal active
Memorized operation of stage I>	O22	R	0 = signal not active 1 = signal active
Memorized starting of stage I>>	O23	R	0 = signal not active 1 = signal active
Memorized operation of stage I>>	O24	R	0 = signal not active 1 = signal active
Memorized starting of stage I ₀₁ >	O25	R	0 = signal not active 1 = signal active
Memorized operation of stage I ₀₁ >	O26	R	0 = signal not active 1 = signal active
Memorized starting of stage U ₀ >	O27	R	0 = signal not active 1 = signal active
Memorized operation of stage I ₀₂ >	O28	R	0 = signal not active 1 = signal active
Memorized output signal TS1	O29	R	0 = signal not active 1 = signal active
Memorized output signal SS1	O30	R	0 = signal not active 1 = signal active
Memorized output signal SS2	O31	R	0 = signal not active 1 = signal active
Memorized output signal SS3	O32	R	0 = signal not active 1 = signal active
Memorized output signal TS2	O33	R	0 = signal not active 1 = signal active

Data	Code	Data direct.	Values
PRESENT SETTING VALUES			
Ruling starting value of stage I>	S1	R	0.5...5.0 x I _n
Ruling operating time for stage I>	S2	R	0.05...300 s
Ruling starting value for stage I>>	S3	R	0.5...40 x I _n 999 = not in use
Ruling operating time for stage I>>	S4	R	0.04...300 s
Ruling starting value for stage U ₀ >	S5	R	2.0...80.0% U _n
Ruling starting value for stage I ₀ >	S6	R	1...25.0% I _n
Ruling operating time for stage I ₀₁ >	S7	R	0.1...300 s
Ruling starting value for stage I ₀₂ >	S8	R	2.0...150% I _n 999 = not in use
Ruling checksum of switchgroup SGF1	S9	R	0...255
Ruling checksum of switchgroup SGF2	S10	R	0...255
Ruling checksum of switchgroup SGF3	S11	R	0...255
Ruling checksum of switchgroup SGB1	S12	R	0...255
Ruling checksum of switchgroup SGB2	S13	R	0...255
Ruling checksum of switchgroup SGB3	S14	R	0...255
Ruling checksum of switchgroup SGR1	S15	R	0...255
Ruling checksum of switchgroup SGR2	S16	R	0...255
Ruling checksum of switchgroup SGR3	S17	R	0...255
MAIN SETTING VALUES			
Main starting value for stage I>	S21	R,W(P)	0.5...5.0 x I _n
Main operating time for stage I>	S22	R,W(P)	0.05...300 s
Main starting value for stage I>>	S23	R,W(P)	0.5...40 x I _n
Main operating time for stage I>>	S24	R,W(P)	0.04...300 s
Main starting value for stage U ₀ >	S25	R,W(P)	2.0...80.0% U _n
Main starting value for stage I ₀ >	S26	R,W(P)	1...25.0% I _n
Main operating time for stage I ₀₁ >	S27	R,W(P)	0.1...300 s
Main starting value for stage I ₀₂ >	S28	R,W(P)	2.0...150% I _n
Main checksum of switchgroup SGF1	S29	R,W(P)	0...255
Main checksum of switchgroup SGF2	S30	R,W(P)	0...255
Main checksum of switchgroup SGF3	S31	R,W(P)	0...255
Main checksum of switchgroup SGB1	S32	R,W(P)	0...255
Main checksum of switchgroup SGB2	S33	R,W(P)	0...255
Main checksum of switchgroup SGB3	S34	R,W(P)	0...255
Main checksum of switchgroup SGR1	S35	R,W(P)	0...255
Main checksum of switchgroup SGR2	S36	R,W(P)	0...255
Main checksum of switchgroup SGR3	S37	R,W(P)	0...255
Operation time for circuit breaker failure protection	S61	R,W(P)	0.1...1.0 s

Data	Code	Data direct.	Values
SECOND SETTING VALUES			
Second starting value for stage I>	S41	R,W(P)	0.5...5.0 x I _n
Second operating time for stage I>	S42	R,W(P)	0.05...300 s
Second starting value for stage I>>	S43	R,W(P)	0.5...40 x I _n
Second operating time for stage I>>	S44	R,W(P)	0.04...300 s
Second starting value for stage U ₀ >	S45	R,W(P)	2.0...80.0% U _n
Second starting value for stage I ₀₁ >	S46	R,W(P)	1...25.0% I _n
Second operating time for stage I ₀₁ >	S47	R,W(P)	0.1...300 s
Second starting value for stage I ₀₂ >	S48	R,W(P)	2.0...150% I _n
Second checksum of switchgroup SGF1	S49	R,W(P)	0...255
Second checksum of switchgroup SGF2	S50	R,W(P)	0...255
Second checksum of switchgroup SGF3	S51	R,W(P)	0...255
Second checksum of switchgroup SGB1	S52	R,W(P)	0...255
Second checksum of switchgroup SGB2	S53	R,W(P)	0...255
Second checksum of switchgroup SGB3	S54	R,W(P)	0...255
Second checksum of switchgroup SGR1	S55	R,W(P)	0...255
Second checksum of switchgroup SGR2	S56	R,W(P)	0...255
Second checksum of switchgroup SGR3	S57	R,W(P)	0...255
Operation time for circuit breaker failure protection	S61	R,W(P)	0.1...1.0 s
RECORDED PARAMETERS			
Current on phase L1 at starting or operation	V11...V51	R	0...63 x I _n
Current on phase L3 at starting or operation	V12...V52	R	0...63 x I _n
Residual voltage U ₀ at starting or operation	V13...V53	R	0...106% U _n
Neutral current I ₀ at starting or operation	V14...V54	R	0...210% I _n
Duration of the latest starting situation of stage I>	V15...V55	R	0...100 %
Duration of the latest starting situation of stage I>>	V16...V56	R	0...100 %
Duration of the latest starting situation of stage I ₀₁ >	V17...V57	R	0...100 %
Duration of the latest starting situation of stage I ₀₂ >	V18...V58	R	0...100 %
Phase angle φ between basic angle φ _b and I ₀	V19...V59	R	-180°...0°...180°, 999 = signal too low to be measured
Maximum demand current for 15 min.	V1	R	0...2.5 x I _n
Number of startings of stage I>	V2	R	0...255
Number of startings of stage I>>	V3	R	0...255
Number of startings of stage I ₀₁ >	V4	R	0...255
Number of startings of stage I ₀₂ >	V5	R	0...255
Phase condition during trip	V6	R	1 = U ₀ >, 2 = I>(L3) 4 = I>(L1), 8 = I ₀₁ > 16 = U ₀ >>, 32 = I>>(L3) 64 = I>>(L1) 128 = I ₀₂ >
Operation indicator	V7	R	0...9
Highest maximum demand current 15 min value	V8	R	0...2.55 x I _n

Data	Code	Data direct.	Values
CONTROL PARAMETERS			
Resetting of output relays at self-holding	V101	W	1 = reset
Resetting of output relays and registers	V102	W	1 = reset
Remote control of settings	V150	R,W	0 = main settings activated 1 = second settings activated
Switchgroup SGX	V152	R,W(P)	0...63
Event mask word for I> and I>>stage events	V155	R,W	0...255, see section event codes
Event mask word for U ₀ >, I ₀₁ and I ₀₂ > stage events	V156	R,W	0...255, see section event codes
Event mask word for output signal events	V157	R,W	0...1023, see section event codes
Opening of password for remote settings	V160	W	1...999
Changing or closing of password for remote settings	V161	W(P)	0...999
Activating of self-supervision output	V165	W	1 = self-supervision output is activated and IRF led turned on 0 = off
Formatting of EEPROM	V167	W(P)	2 = formatting
Internal error code	V169	R	0...255
Data communication address of the module	V200	R,W	1...254
Data transfer rate	V201	R,W	4800 or 9600 Bd (R) 4.8 or 9.6 kBd (W)
Programme version number	V205	R	089_
Event register reading	L	R	time, channel number and event code
Re-reading of event register	B	R	time, channel and event code
Type designation of the module	F	R	SPCJ 4D44
Reading of module status data	C	R	0 = normal state 1 = module been subject to automatic reset 2 = overflow of event register 3 = events 1 and 2 together
Resetting of module state data	C	W	0 = resetting
Time reading and setting	T	R,W	0.000...59.999 s

The event register can be read with the L command only once. Should a fault occur e.g. in the data transfer, the contents of the event register read with an L command may be re-read with a B command. When required, the B command can be repeated. Generally, the control data communicator reads the event data and forwards them to the output device. Under normal conditions the event register of the relay module is empty. In the same way the data communicator resets abnormal status data, thus this data is normally zero.

The setting values S1...S17 are the setting values used by the protection programs. These values are

set either as the main settings and switchgroup checksums S21...S37 or as the corresponding second settings S41...S57. All the settings can be read or written. A condition for writing is that the remote set password has been opened.

When changing settings, the relay module checks that the variables given are within the ranges specified in the technical data of the relay module. If a value beyond the limits is given to the relay module, either manually or by remote setting, the module will not store the value but will keep the previous setting value.

Fault codes

Once the internal self-supervision system has detected a permanent relay fault the red IRF indicator is lit and the output relay of the self-supervision system operates. Further, in most fault situations an autodiagnostic fault code is shown on the display. The fault code is composed of a red number 1 and a green code

number which indicates the fault type. When a fault code appears on the display, the code number should be recorded and submitted to the authorized repair shop when overhaul is ordered. Below a list of some of the autodiagnostic fault codes that might appear on the display of the relay module SPCJ 4D44:

Fault code	Type of error in module
4	Trip relay path broken or output relay card missing
30	Faulty program memory (ROM)
50	Faulty work memory (RAM)
51	Parameter memory (EEPROM) block 1 faulty
52	Parameter memory (EEPROM) block 2 faulty
53	Parameter memory (EEPROM) block 1 and block 2 faulty
54	Parameter memory (EEPROM) block 1 and block 2 faulty with different checksums
56	Parameter memory (EEPROM) key faulty. Format by writing a "2" to variable V167
195	Too low a value in reference channel with multiplier 1
131	Too low a value in reference channel with multiplier 5
67	Too low a value in reference channel with multiplier 25
203	Too high a value in reference channel with multiplier 1
139	Too high a value in reference channel with multiplier 5
75	Too high a value in reference channel with multiplier 25
252	Faulty hardware filter on E/F channel
253	No interruptions from the A/D converter

Appendix 1

General

Appendix 1 describes the changes made to the program versions SW 089 C and SW 089 D of the combined phase overcurrent and directional earth-fault module SPCJ 4D44. An optional

function for the detection of intermittent earth faults has been added to the earth-fault stage $I_{02}>$.

Intermittent earth faults

A typical intermittent earth fault includes one or several earth fault current peaks during one disruptive discharge. The peak current is very

high and the time between the disruptive discharges may exceed 200 ms.

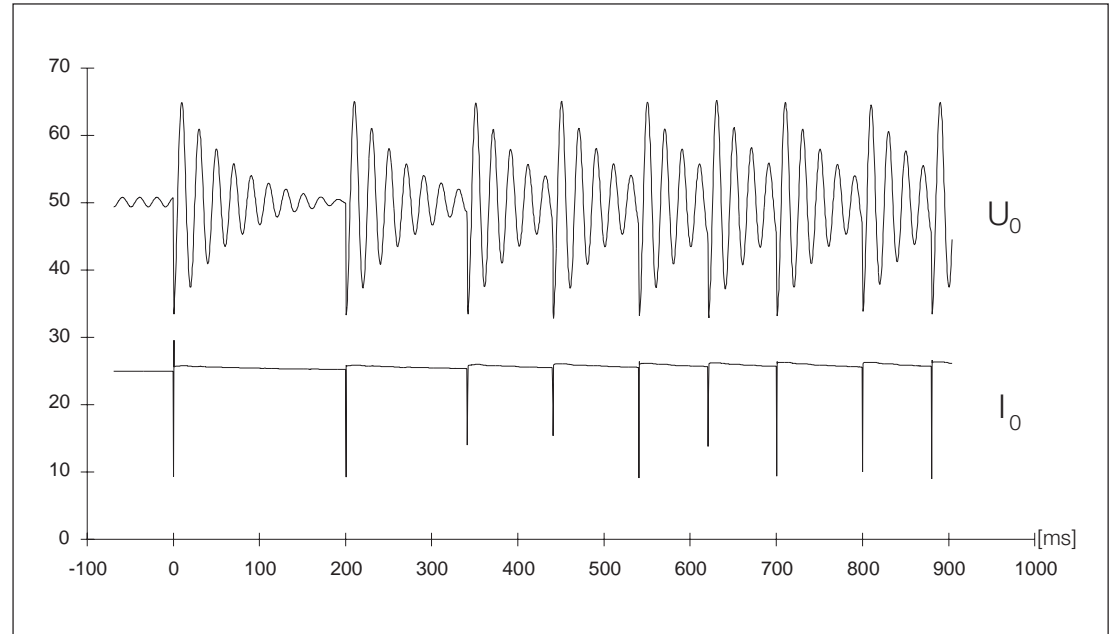

Figure 1. An intermittent earth fault measured in an underground cable.

Description of functions added to program versions SW 089 C and SW 089 D

The $I_{02}>$ stage can be selected to operate either as a normal earth-fault stage or as an intermittent earth-fault stage. When $SGF3/6 = 0$, the

stage operates as a normal earth-fault stage. When $SGF3/6 = 1$, the stage is able to detect intermittent earth faults.

Description of function of stages $I_{01}>$ and $I_{02}>$, when $SGF3/6=1$

The directional earth-fault stage $I_{01}>$ operates on resistive earth faults and intermittent earth faults with disruptive discharge pulses of up to 100 ms. The $I_{02}>$ stage is blocked when the $I_{01}>$ stage is activated.

At intermittent earth faults with disruptive discharge pulses between 100 ms and 500 ms, i.e. outside the operating range of the $I_{01}>$ stage, the blocking of stage $I_{02}>$ will be eliminated. Then the $I_{02}>$ stage is activated, delivering a trip signal in 750 ms, if U_0 , I_0 and the phase angle fulfil the start criteria.

Appendix 2

General

Appendix 2 describes the changes made to the earth-fault stages $I_{01}>$ or $I_{02}>$ of the combined phase overcurrent and directional earth-fault module SPCJ 4D44 with program version SW

089 F and later. These changes have been made to improve the functions of the faulted line and healthy lines.

Extending the negative part of the operation sector of the earth-fault stages

When the $I_{02}>$ stage has been programmed for detecting intermittent earth faults (SGF3/6=1), the negative operation sector will automatically be extended to -120° or -170° , as selected with switch SGF3/7. When the switch is in position 0, the operation area will be -120° , and when the switch is in position 1, it will be -170° . The

extended operation area applies to both directional earth-fault stages. As the operation sector of the earth-fault stages can be set to -120° or -170° , the function of the earth-fault relay of the faulted line can be considerably improved at an intermittent earth fault.

Reducing the positive part of the operation sector of the $I_{02}>$ stage

When the $I_{02}>$ stage has been programmed for detecting intermittent earth faults, the positive operation sector can be set at $+60^\circ$, $+68^\circ$, $+70^\circ$, $+78^\circ$, $+80^\circ$ or $+88^\circ$ using the programming switches SGX/5 and SGX/6. The positive opera-

tion sector can only be reduced for the $I_{02}>$ stage. This function can be selected in special situations, where the phase angle measured for the healthy line may turn towards the operation area.

Selectable operate times, $t_{02}>$ for stage $I_{02}>$

Four optional operate times have been added to the $I_{02}>$ stage. The operate times are selected with the switches SGX/1 and SGX/2.

- When SGF3/6=0, the operate times 0.10 s, 1.50 s, 2.00 s and 2.50 s will be available
- When SGF3/6=1, the operate times 0.75 s, 1.50 s, 2.00 s and 2.50 s will be available

Selectable $I_0\cos\phi$ function for the earth-fault stages

An $I_0\cos\phi$ function, selectable with the programming switches SGX/3 and SGX/4, has been added to the directional earth-fault stage. Under normal conditions, the angle measuring principle is used, but, when required, the $I_0\cos\phi$

principle can be used to obtain selectivity with other $I_0\cos\phi$ measuring relays and to improve the function of healthy lines in an earth-fault situation.

Programming switches SGF3/7 and SGX/1...6

The programming switch SGF3/7 has been assigned a function. In addition, the module has been provided with a new switchgroup SGX, which can be programmed either from the front

panel of the module, via submenu 6 of register A, or over the serial SPA communication, parameter V152.

Switch	Function	Default setting
SGF3/7	<p>Selection of the extended negative operation sector for the directional earth-fault stages.</p> <p>The extended negative operation sector can only be selected when the $I_{02}>$ stage has been programmed to detect intermittent earth faults, i.e. SGF3/6 = 1.</p> <p><i>N.B. The extended operation sector -120° or -170° can only be selected at phase-angle measuring function or at $I_0\cos\phi$ function on the positive sector. See Fig. 1 and 2, page 42, 43</i></p> <p>When SGF3/7 = 0, the negative operation sector is extended to -120° When SGF3/7 = 1, the negative operation sector is extended to -170°</p>	0
SGF3/8	Not in use	0

Switchgroup SGX is used for selecting the following functions.

Switch	Function	Default setting																				
SGX/1 SGX/2	<p>Selection of operate time t_{02} for stage I_{02} <i>N.B! The switch SGF3/6 also affects the operate time t_{02} as follows:</i></p> <table border="1"> <thead> <tr> <th>SGX/1</th> <th>SGX/2</th> <th>I_{02} normal E/F (SGF3/6=0)</th> <th>I_{02} Interm. E/F (SGF3/6=1)</th> </tr> </thead> <tbody> <tr> <td>0</td> <td>0</td> <td>0.10 s</td> <td>0.75 s</td> </tr> <tr> <td>1</td> <td>0</td> <td>1.50 s</td> <td>1.50 s</td> </tr> <tr> <td>0</td> <td>1</td> <td>2.00 s</td> <td>2.00 s</td> </tr> <tr> <td>1</td> <td>1</td> <td>2.50 s</td> <td>2.50 s</td> </tr> </tbody> </table>	SGX/1	SGX/2	I_{02} normal E/F (SGF3/6=0)	I_{02} Interm. E/F (SGF3/6=1)	0	0	0.10 s	0.75 s	1	0	1.50 s	1.50 s	0	1	2.00 s	2.00 s	1	1	2.50 s	2.50 s	0
SGX/1	SGX/2	I_{02} normal E/F (SGF3/6=0)	I_{02} Interm. E/F (SGF3/6=1)																			
0	0	0.10 s	0.75 s																			
1	0	1.50 s	1.50 s																			
0	1	2.00 s	2.00 s																			
1	1	2.50 s	2.50 s																			
SGX/3 SGX/4	<p>Selection of operation principle for the directional earth-fault stages I_{01} and I_{02}</p> <table border="1"> <thead> <tr> <th>SGX/3</th> <th>SGX/4</th> <th>Operation principle</th> </tr> </thead> <tbody> <tr> <td>0</td> <td>0</td> <td>Phase-angle measuring function on the positive and the negative sector</td> </tr> <tr> <td>1</td> <td>0</td> <td>$I_0 \cos \varphi$ function for the positive sector and phase-angle measuring function for the negative sector.</td> </tr> <tr> <td>0</td> <td>1</td> <td>$I_0 \cos \varphi$ function for both the negative and the positive sector¹⁾</td> </tr> <tr> <td>1</td> <td>1</td> <td>$I_0 \cos \varphi$ function for both the negative and the positive sector¹⁾</td> </tr> </tbody> </table> <p>¹⁾ The operation sector $\Delta \varphi$ will automatically be symmetrical, when $I_0 \cos \varphi$ function has been selected both for the negative sector and the positive sector, see Fig. 3, page 44.</p>	SGX/3	SGX/4	Operation principle	0	0	Phase-angle measuring function on the positive and the negative sector	1	0	$I_0 \cos \varphi$ function for the positive sector and phase-angle measuring function for the negative sector.	0	1	$I_0 \cos \varphi$ function for both the negative and the positive sector ¹⁾	1	1	$I_0 \cos \varphi$ function for both the negative and the positive sector ¹⁾	0					
SGX/3	SGX/4	Operation principle																				
0	0	Phase-angle measuring function on the positive and the negative sector																				
1	0	$I_0 \cos \varphi$ function for the positive sector and phase-angle measuring function for the negative sector.																				
0	1	$I_0 \cos \varphi$ function for both the negative and the positive sector ¹⁾																				
1	1	$I_0 \cos \varphi$ function for both the negative and the positive sector ¹⁾																				
SGX/5 SGX/6	<p>Selection of positive operation sector for the directional earth-fault stage I_{02} <i>N.B! The positive operation sector can be selected only when the I_{02} stage has been programmed to detect intermittent earth faults (SGF3/6=1)</i></p> <table border="1"> <thead> <tr> <th>SGX/5</th> <th>SGX/6</th> <th>Negative operation sector - 120° (SGF3/7=0)</th> <th>Negative operation sector - 170° (SGF3/7=1)</th> </tr> </thead> <tbody> <tr> <td>0</td> <td>0</td> <td>-120°...0°...+80°²⁾</td> <td>-170°...0°...+80°²⁾</td> </tr> <tr> <td>1</td> <td>0</td> <td>-120°...0°...+70°²⁾</td> <td>-170°...0°...+70°²⁾</td> </tr> <tr> <td>0</td> <td>1</td> <td>-120°...0°...+60°²⁾</td> <td>-170°...0°...+60°²⁾</td> </tr> <tr> <td>1</td> <td>1</td> <td>-120°...0°...+60°²⁾</td> <td>-170°...0°...+60°²⁾</td> </tr> </tbody> </table> <p>²⁾ If SGF3/5=1, 8° will be added to the positive operation sector.</p>	SGX/5	SGX/6	Negative operation sector - 120° (SGF3/7=0)	Negative operation sector - 170° (SGF3/7=1)	0	0	-120°...0°...+80° ²⁾	-170°...0°...+80° ²⁾	1	0	-120°...0°...+70° ²⁾	-170°...0°...+70° ²⁾	0	1	-120°...0°...+60° ²⁾	-170°...0°...+60° ²⁾	1	1	-120°...0°...+60° ²⁾	-170°...0°...+60° ²⁾	0
SGX/5	SGX/6	Negative operation sector - 120° (SGF3/7=0)	Negative operation sector - 170° (SGF3/7=1)																			
0	0	-120°...0°...+80° ²⁾	-170°...0°...+80° ²⁾																			
1	0	-120°...0°...+70° ²⁾	-170°...0°...+70° ²⁾																			
0	1	-120°...0°...+60° ²⁾	-170°...0°...+60° ²⁾																			
1	1	-120°...0°...+60° ²⁾	-170°...0°...+60° ²⁾																			
SGX/7 SGX/8	Not in use	0																				

1. Earth-fault stages with phase-angle measuring function

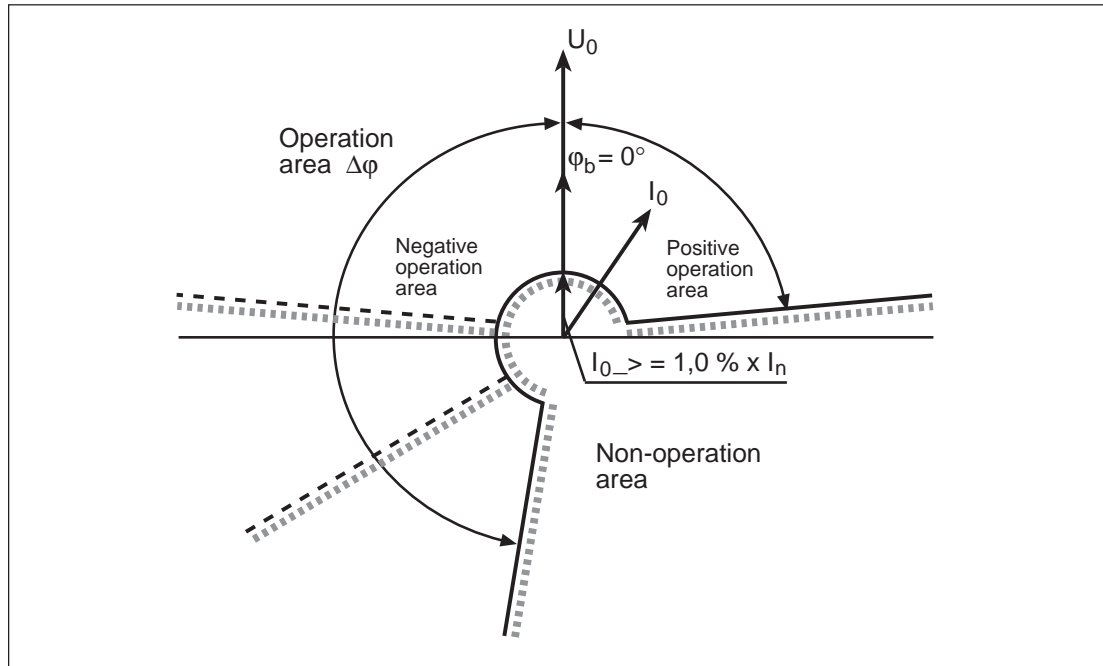

Fig. 1. Example of three operation areas $-80^\circ \dots 0^\circ \dots +80^\circ$, $-120^\circ \dots 0^\circ \dots +80^\circ$ and $-170^\circ \dots 0^\circ \dots +80^\circ$, when the basic angle $\varphi_b = 0^\circ$.

Table 1: Operation areas to be selected with the SGF_ and SGX switches at phase-angle measuring function

Switch		Earth-fault stages with phase-angle measuring function SGX/3 = 0 & SGX/4 = 0			
		Earth-fault stages set to operate on normal earth faults, (SGF3/6=0)		$I_{02} >$ stage set to operate on intermittent earth faults, (SGF3/6 = 1)	
Stage $I_{01} >$					
SGF3/5		SGF3/6 = 0		SGF3/6 = 1 & SGF3/7 = 0	SGF3/6 = 1 & SGF3/7 = 1
0		$-80^\circ \dots 0^\circ \dots +80^\circ$		$-120^\circ \dots 0^\circ \dots +80^\circ$	$-170^\circ \dots 0^\circ \dots +80^\circ$
1		$-88^\circ \dots 0^\circ \dots +88^\circ$		$-120^\circ \dots 0^\circ \dots +88^\circ$	$-170^\circ \dots 0^\circ \dots +88^\circ$
Stage $I_{02} >$					
SGF3/5	SGX/5	SGX/6	SGF3/6 = 0	SGF3/6 = 1 & SGF3/7 = 0	SGF3/6 = 1 & SGF3/7 = 1
0	0	0	$-80^\circ \dots 0^\circ \dots +80^\circ$	$-120^\circ \dots 0^\circ \dots +80^\circ$	$-170^\circ \dots 0^\circ \dots +80^\circ$
0	1	0	$-80^\circ \dots 0^\circ \dots +80^\circ$	$-120^\circ \dots 0^\circ \dots +70^\circ$	$-170^\circ \dots 0^\circ \dots +70^\circ$
0	0	1	$-80^\circ \dots 0^\circ \dots +80^\circ$	$-120^\circ \dots 0^\circ \dots +60^\circ$	$-170^\circ \dots 0^\circ \dots +60^\circ$
1	0	0	$-88^\circ \dots 0^\circ \dots +88^\circ$	$-120^\circ \dots 0^\circ \dots +88^\circ$	$-170^\circ \dots 0^\circ \dots +88^\circ$
1	1	0	$-88^\circ \dots 0^\circ \dots +88^\circ$	$-120^\circ \dots 0^\circ \dots +78^\circ$	$-170^\circ \dots 0^\circ \dots +78^\circ$
1	0	1	$-88^\circ \dots 0^\circ \dots +88^\circ$	$-120^\circ \dots 0^\circ \dots +68^\circ$	$-170^\circ \dots 0^\circ \dots +68^\circ$

2. Earth-fault stages with $I_0 \cos \varphi$ function on the positive sector and phase-angle measuring function on the negative sector

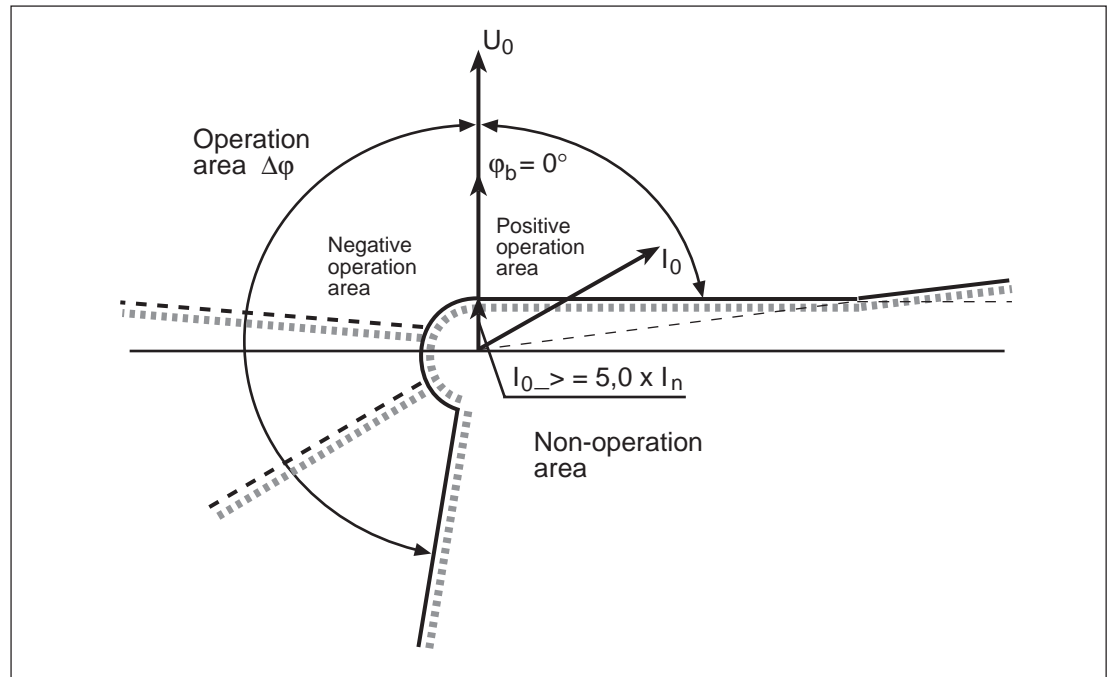

Fig.2. Example of three operation areas, $-80^\circ \dots 0^\circ \dots +80^\circ \& I_0 \cos \varphi$, $-120^\circ \dots 0^\circ \dots +80^\circ \& I_0 \cos \varphi$ and $-170^\circ \dots 0^\circ \dots +80^\circ \& I_0 \cos \varphi$, when the basic angle $\varphi_b = 0^\circ$.

Table 2: Operation areas to be selected with the SGF_ and SGX switches at $I_0 \cos \varphi$ function on the positive sector and phase-angle measuring function on the negative sector

Switch		Earth-fault stages with $I_0 \cos \varphi$ function on the positive sector and phase-angle measuring function on the negative sector. SGX/3 = 1 & SGX/4 = 0			
		Earth-fault stages set to operate on normal earth faults, SGF3/6 = 0	$I_{02} >$ stage set to operate on intermittent earth faults, SGF3/6 = 1		
Stage $I_{01} >$					
SGF3/5		SGF3/6 = 0		SGF3/6 = 1 & SGF3/7 = 0	SGF3/6 = 1 & SGF3/7 = 1
0		$-80^\circ \dots 0^\circ \dots +80^\circ \& I_0 \cos \varphi$		$-120^\circ \dots 0^\circ \dots +80^\circ \& I_0 \cos \varphi$	$-170^\circ \dots 0^\circ \dots +80^\circ \& I_0 \cos \varphi$
1		$-88^\circ \dots 0^\circ \dots +88^\circ \& I_0 \cos \varphi$		$-120^\circ \dots 0^\circ \dots +88^\circ \& I_0 \cos \varphi$	$-170^\circ \dots 0^\circ \dots +88^\circ \& I_0 \cos \varphi$
Stage $I_{02} >$					
SGF3/5	SGX/5	SGX/6	SGF3/6 = 0	SGF3/6 = 1 & SGF3/7 = 0	SGF3/6 = 1 & SGF3/7 = 1
0	0	0	$-80^\circ \dots 0^\circ \dots +80^\circ \& I_0 \cos \varphi$	$-120^\circ \dots 0^\circ \dots +80^\circ \& I_0 \cos \varphi$	$-170^\circ \dots 0^\circ \dots +80^\circ \& I_0 \cos \varphi$
0	1	0	$-80^\circ \dots 0^\circ \dots +80^\circ \& I_0 \cos \varphi$	$-120^\circ \dots 0^\circ \dots +70^\circ \& I_0 \cos \varphi$	$-170^\circ \dots 0^\circ \dots +70^\circ \& I_0 \cos \varphi$
0	0	1	$-80^\circ \dots 0^\circ \dots +80^\circ \& I_0 \cos \varphi$	$-120^\circ \dots 0^\circ \dots +60^\circ \& I_0 \cos \varphi$	$-170^\circ \dots 0^\circ \dots +60^\circ \& I_0 \cos \varphi$
1	0	0	$-88^\circ \dots 0^\circ \dots +88^\circ \& I_0 \cos \varphi$	$-120^\circ \dots 0^\circ \dots +88^\circ \& I_0 \cos \varphi$	$-170^\circ \dots 0^\circ \dots +88^\circ \& I_0 \cos \varphi$
1	1	0	$-88^\circ \dots 0^\circ \dots +88^\circ \& I_0 \cos \varphi$	$-120^\circ \dots 0^\circ \dots +78^\circ \& I_0 \cos \varphi$	$-170^\circ \dots 0^\circ \dots +78^\circ \& I_0 \cos \varphi$
1	0	1	$-88^\circ \dots 0^\circ \dots +88^\circ \& I_0 \cos \varphi$	$-120^\circ \dots 0^\circ \dots +68^\circ \& I_0 \cos \varphi$	$-170^\circ \dots 0^\circ \dots +68^\circ \& I_0 \cos \varphi$

3. Earth-fault stages with $I_0 \cos \varphi$ function on the positive and the negative sector

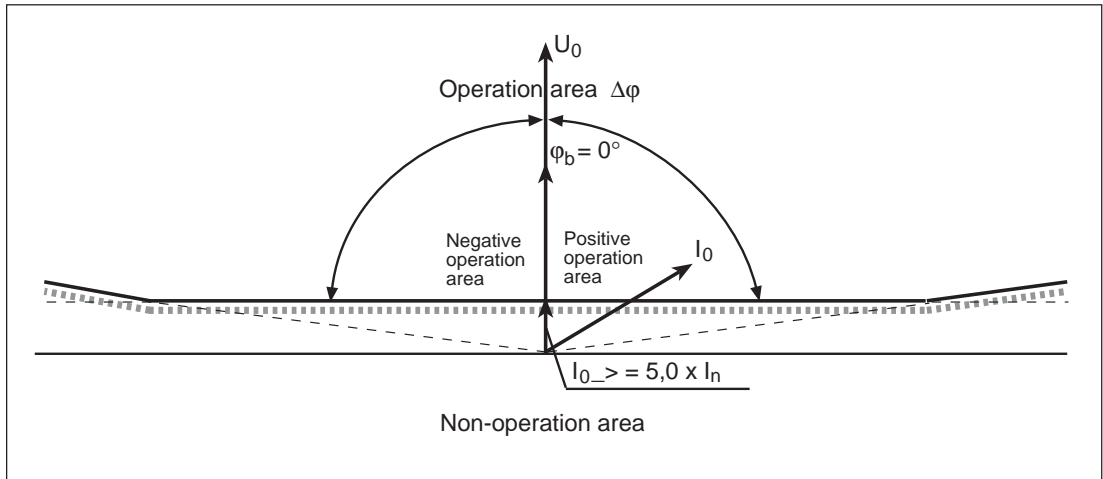

Fig.3. Example of operation area $-80^\circ \& I_0 \cos \varphi \dots 0^\circ \dots +80^\circ \& I_0 \cos \varphi$, when the basic angle $\varphi_b = 0^\circ$.

Table 3: Operation areas to be selected with switches SGF_ and SGX at $I_0 \cos \varphi$ function on the negative and the positive sector.

Switch	Earth-fault stages with $I_0 \cos \varphi$ function on both sectors, SGX/3 = 0 & SGX/4 = 1		
	Earth-fault stages set to operate on normal earth faults, SGF3/6 = 0		$I_{02} >$ stage set to operate on intermittent earth faults, SGF3/6 = 1
Stage $I_{01} >$			
SGF3/5		SGF3/6 = 0	SGF3/6 = 1
0		$-80^\circ \& I_0 \cos \varphi \dots 0^\circ \dots +80^\circ \& I_0 \cos \varphi$	$-80^\circ \& I_0 \cos \varphi \dots 0^\circ \dots +80^\circ \& I_0 \cos \varphi$
1		$-88^\circ \& I_0 \cos \varphi \dots 0^\circ \dots +88^\circ \& I_0 \cos \varphi$	$-88^\circ \& I_0 \cos \varphi \dots 0^\circ \dots +88^\circ \& I_0 \cos \varphi$
Stage $I_{02} >$			
SGF3/5	SGX/5	SGX/6	SGF3/6 = 0
0	0	0	$-80^\circ \& I_0 \cos \varphi \dots 0^\circ \dots +80^\circ \& I_0 \cos \varphi$
0	1	0	$-80^\circ \& I_0 \cos \varphi \dots 0^\circ \dots +80^\circ \& I_0 \cos \varphi$
0	0	1	$-80^\circ \& I_0 \cos \varphi \dots 0^\circ \dots +80^\circ \& I_0 \cos \varphi$
1	0	0	$-88^\circ \& I_0 \cos \varphi \dots 0^\circ \dots +88^\circ \& I_0 \cos \varphi$
1	1	0	$-88^\circ \& I_0 \cos \varphi \dots 0^\circ \dots +88^\circ \& I_0 \cos \varphi$
1	0	1	$-88^\circ \& I_0 \cos \varphi \dots 0^\circ \dots +88^\circ \& I_0 \cos \varphi$
			SGF3/6 = 1
0	0	0	$-80^\circ \& I_0 \cos \varphi \dots 0^\circ \dots +80^\circ \& I_0 \cos \varphi$
0	1	0	$-70^\circ \& I_0 \cos \varphi \dots 0^\circ \dots +70^\circ \& I_0 \cos \varphi$
0	0	1	$-60^\circ \& I_0 \cos \varphi \dots 0^\circ \dots +60^\circ \& I_0 \cos \varphi$
1	0	0	$-88^\circ \& I_0 \cos \varphi \dots 0^\circ \dots +88^\circ \& I_0 \cos \varphi$
1	1	0	$-78^\circ \& I_0 \cos \varphi \dots 0^\circ \dots +78^\circ \& I_0 \cos \varphi$
1	0	1	$-68^\circ \& I_0 \cos \varphi \dots 0^\circ \dots +68^\circ \& I_0 \cos \varphi$

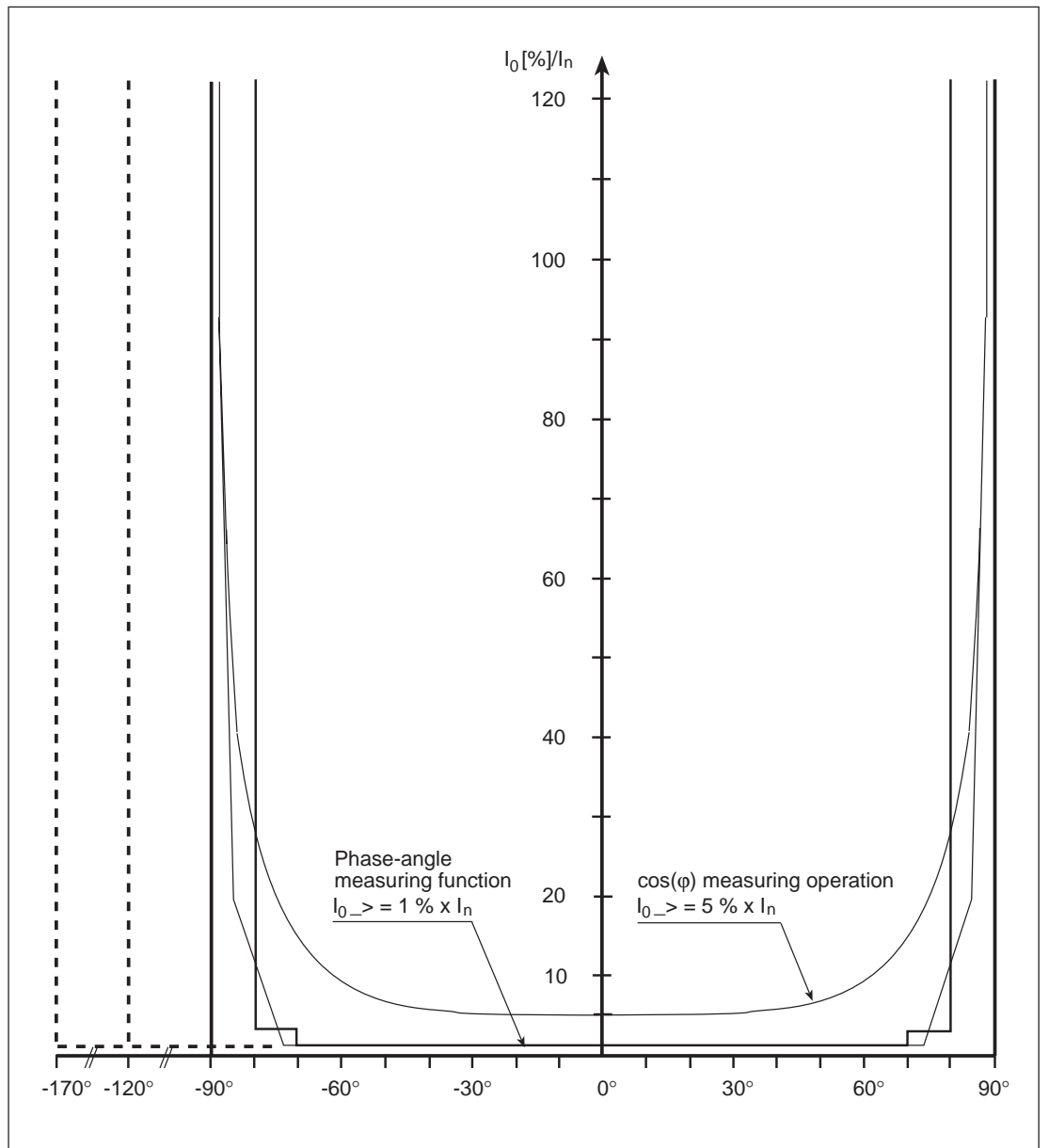

Fig. 4. Overview of operation areas of the directional earth-fault stages, when the basic angle $\varphi_b = 0^\circ$ and the start current $I_{0_>} = 1.0 \% \times I_n$ at phase-angle measuring function and $5.0 \% \times I_n$ at $I_0 \cos \varphi$ measuring operation.

**Technical data
affected by
versions
SW 089 E, F**

Operation principles of earth-fault stages for $I_{01}>$ or $I_{02}>$

Operation sector $\Delta\phi$	SW: - 089 C, D:	$\pm 80^\circ, \pm 88^\circ$
	- 089 E:	$\pm 80^\circ, \pm 88^\circ, -120^\circ$
	- 089 F:	$\pm 80^\circ, \pm 88^\circ, -120^\circ, -170^\circ (+60^\circ, +68^\circ, +70^\circ, +78^\circ)^*$
*) The values in brackets apply to the $I_{02}>$ stage when $SGF3/6=1$		
Operation principle	SW: - 089 F:	Phase-angle measuring function or $I_0\cos\phi$ function

High-set earth-fault stage $I_{02}>$

Operate time, $t_{02}>$

- $SGF3/6=0$	SW: - 089 C, D, E:	0.1s
	- 089 F:	0.1, 1.5, 2.0, 2.5 s
- $SGF3/6=1,$	SW: - 089 C, D, E:	0.75 s
	- 089 F	0.75, 1.5, 2.0, 2.5 s

**Recommendation
for configuring
the module
SPCJ 4D44
SW 089 F**

To maximize the functionality of the module at earth faults apt to develop into intermittent faults, the following module settings are recommended:

Definition of setting values:

- The residual voltage $U_0>$ is calculated as normal.
- The start current for the earth-fault stage $I_{01}>$ is calculated as normal.
- The start current recommended for the earth-fault stage $I_{02}>$ exceeds the start current of the $I_{01}>$ by 10%.
- The operate time for $t_{01}>$ is calculated as normal.

Programming of switches:

$SGF2/1 = 1$	basic angle, $\phi_b = 0^\circ$, for resonant-earthed networks
$SGF2/2 = 1$	- " -
$SGF3/5 = 0$	operation area $\pm 80^\circ$
$SGF3/6 = 1$	$I_{02}>$ intermittent function
$SGF3/7 = 1$	negative operation area of stages $I_{01}>$ and $I_{02}>$ -170°
$SGX/1 = 0$	operate time $t_{02}> = 0.75$ s
$SGX/2 = 0$	- " -
$SGX/3 = 1$	$I_0\cos\phi$ function on the positive operation area
$SGX/4 = 0$	- " -
$SGX/5 = 1$	positive operation area of stage $I_{02}>$ $+70^\circ$
$SGX/6 = 0$	- " -

Other settings:

Other module settings have to be adapted to the calculations made for the line and the network.

Other issues to consider

Reactor compensation:

To obtain maximum protection for both the faulted line and the healthy lines, a compensation degree of 5...10% (overcompensated) is recommended.

Residual voltage relay:

To avoid unselective tripping by the residual voltage relay, the operate time of the relay must be long enough compared to the operate times of the directional earth-fault relays of the feeders. At an intermittent earth fault, the earth-fault stages of the faulted line may be delayed. For this reason, the operate time of the earth-fault stage of the faulted line should be at least 5 s for the residual voltage relay (or at least twice the operate time of the directional earth-fault stages).

Local recommendations and regulations:

In this document we have paid no attention to local recommendations and regulations, which have to be considered by the user.

General characteristics of D-type relay modules

User's manual and Technical description

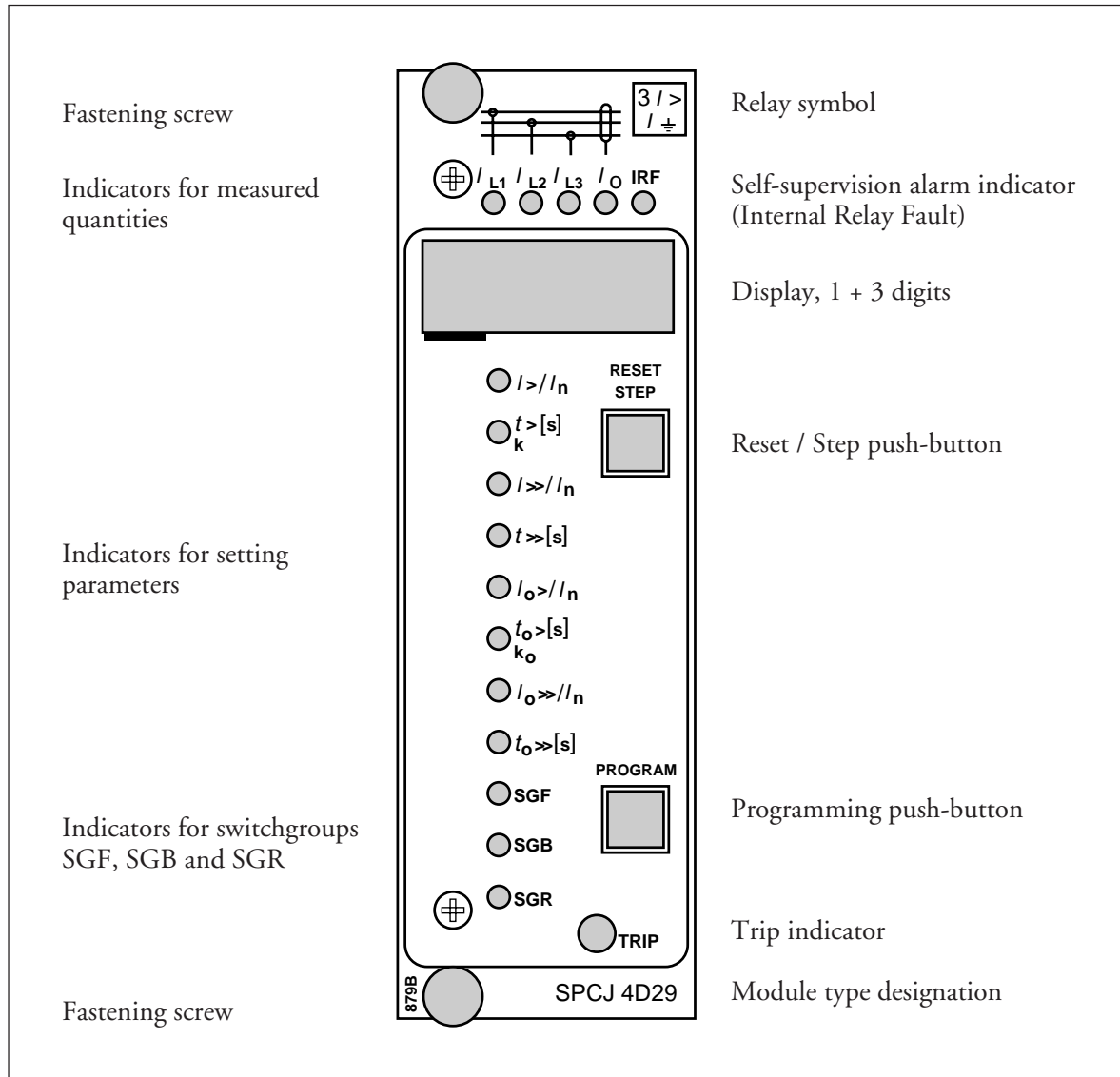

General characteristics of D type relay modules

Data subject to change without notice

Contents

Front panel lay-out	1
Control push buttons	3
Display	3
Display main menu	3
Display submenus	3
Selector switchgroups SGF, SGB, SGR	4
Settings	4
Setting mode	4
Example 1: Setting of relay operation values	7
Example 2: Setting of relay switchgroups	9
Recorded information	11
Trip test function	12
Example 3: Forced activation of outputs	13
Operation indicators	15
Fault codes	15

Control push-buttons	The front panel of the relay module contains two push buttons. The RESET / STEP push button is used for resetting operation indicators and for stepping forward or backward in the display main menu or submenus. The PROGRAM push button is used for moving from a	certain position in the main menu to the corresponding submenu, for entering the setting mode of a certain parameter and together with the STEP push button for storing the set values. The different operations are described in the subsequent paragraphs in this manual.
Display	The measured and set values and the recorded data are shown on the display of the protection relay module. The display consists of four digits. The three green digits to the right show the measured, set or recorded value and the leftmost red digit shows the code number of the register. The measured or set value displayed is indicated by the adjacent yellow LED indicator on the front panel. When a recorded fault value is being displayed the red digit shows the number of the corresponding register. When the display functions as an operation indicator the red digit alone is shown.	When the auxiliary voltage of a protection relay module is switched on the module initially tests the display by stepping through all the segments of the display for about 15 seconds. At first the corresponding segments of all digits are lit one by one clockwise, including the decimal points. Then the center segment of each digit is lit one by one. The complete sequence is carried out twice. When the test is finished the display turns dark. The testing can be interrupted by pressing the STEP push button. The protection functions of the relay module are alerted throughout the testing.
Display main menu	Any data required during normal operation are accessible in the main menu i.e. present measured values, present setting values and recorded parameter values. The data to be shown in the main menu are sequentially called up for display by means of the STEP push button. When the STEP push button is pressed for about one second, the display moves forward in the display sequence. When the push button is pressed for about 0.5 seconds, the display moves backward in the display sequence.	From a dark display only forward movement is possible. When the STEP push button is pushed constantly, the display continuously moves forward stopping for a while in the dark position. Unless the display is switched off by stepping to the dark point, it remains lit for about 5 minutes from the moment the STEP push button was last pushed. After the 5 minutes' time-out the display is switched off.
Display submenus	Less important values and values not very often set are displayed in the submenus. The number of submenus varies with different relay module types. The submenus are presented in the description of the concerned protection relay module. A submenu is entered from the main menu by pressing the PROGRAM push button for about one second. When the push button is released, the red digit of the display starts flashing, indicating that a submenu has been entered. Going from one submenu to another or back to the main menu follows the same principle as when moving from the main menu display to another;	the display moves forward when the STEP push button is pushed for one second and backward when it is pushed for 0.5 seconds. The main menu has been re-entered when the red display turns dark. When a submenu is entered from a main menu of a measured or set value indicated by a LED indicator, the indicator remains lit and the address window of the display starts flashing. A submenu position is indicated by a flashing red address number alone on the display without any lit set value LED indicator on the front panel.

Selector switch-groups SGF, SGB and SGR

Part of the settings and the selections of the operation characteristic of the relay modules in various applications are made with the selector switchgroups SG_. The switchgroups are software based and thus not physically to be found in the hardware of the relay module. The indicator of the switchgroup is lit when the checksum of the switchgroup is shown on the display. Starting from the displayed checksum and by entering the setting mode, the switches can be set one by one as if they were real physical switches. At the end of the setting procedure, a checksum for the whole switchgroup is shown. The checksum can be used for verifying that the switches have been properly set. Fig. 2 shows an example of a manual checksum calculation.

When the checksum calculated according to the example equals the checksum indicated on the display of the relay module, the switches in the concerned switchgroup are properly set.

Switch No	Pos.		Weight	Value
1	1	x	1	= 1
2	0	x	2	= 0
3	1	x	4	= 4
4	1	x	8	= 8
5	1	x	16	= 16
6	0	x	32	= 0
7	1	x	64	= 64
8	0	x	128	= 0
Checksum		Σ	=	93

Fig. 2. Example of calculating the checksum of a selector switchgroup SG_.

The functions of the selector switches of the different protection relay modules are described in detail in the manuals of the different relay modules.

Settings

Most of the start values and operate times are set by means of the display and the push buttons on the front panel of the relay modules. Each setting has its related indicator which is lit when the concerned setting value is shown on the display.

In addition to the main stack of setting values most D type relay modules allow a second stack of settings. Switching between the main settings

and the second settings can be done in three different ways:

- 1) By command V150 over the serial communication bus
- 2) By an external control signal BS1, BS2 or RRES (BS3)
- 3) Via the push-buttons of the relay module, see submenu 4 of register A.

Setting mode

Generally, when a large number of settings is to be altered, e.g. during commissioning of relay systems, it is recommended that the relay settings are entered with the keyboard of a personal computer provided with the necessary software. When no computer nor software is available or when only a few setting values need to be altered the procedure described below is used.

The registers of the main menu and the submenus contain all parameters that can be set. The settings are made in the so called setting mode, which is accessible from the main menu or a submenu by pressing the PROGRAM push button, until the whole display starts flashing. This position indicates the value of the parameter before it has been altered. By pressing the PROGRAM push button the programming sequence moves forward one step. First the rightmost digit starts flashing while the rest of the display is steady. The flashing digit is set by means of the STEP push button. The flashing

cursor is moved on from digit to digit by pressing the PROGRAM push button and in each stop the setting is performed with the STEP push button. After the parameter values have been set, the decimal point is put in place. At the end the position with the whole display flashing is reached again and the data is ready to be stored.

A set value is recorded in the memory by pressing the push buttons STEP and PROGRAM simultaneously. Until the new value has been recorded a return from the setting mode will have no effect on the setting and the former value will still be valid. Furthermore *any attempt to make a setting outside the permitted limits for a particular parameter will cause the new value to be disqualified and the former value will be maintained.* Return from the setting mode to the main menu or a submenu is possible by pressing the PROGRAM push button until the green digits on the display stop flashing.

NOTE! During any local man-machine communication over the push buttons and the display on the front panel a five minute time-out function is active. Thus, if no push button has been pressed during the last five minutes, the relay returns to its normal state automatically. This means that the display turns dark, the relay escapes from a display mode, a programming routine or any routine going on, when the relay is left untouched. This is a convenient way out of any situation when the user does not know what to do.

Before a relay module is inserted into the relay case, one must assure that the module has been given the correct settings. If there however is

any doubt about the settings of the module to be inserted, the setting values should be read using a spare relay unit or with the relay trip circuits disconnected. If this cannot be done the relay can be set into a non-tripping mode by pressing the PROGRAM push button and powering up the relay module simultaneously. The display will show three dashes "---" to indicate the non-tripping mode. The serial communication is operative and all main and submenus are accessible. In the non-tripping mode unnecessary trippings are avoided and the settings can be checked. *The normal protection relay mode is entered automatically after a timeout of five minutes or ten seconds after the dark display position of the main menu has been entered.*

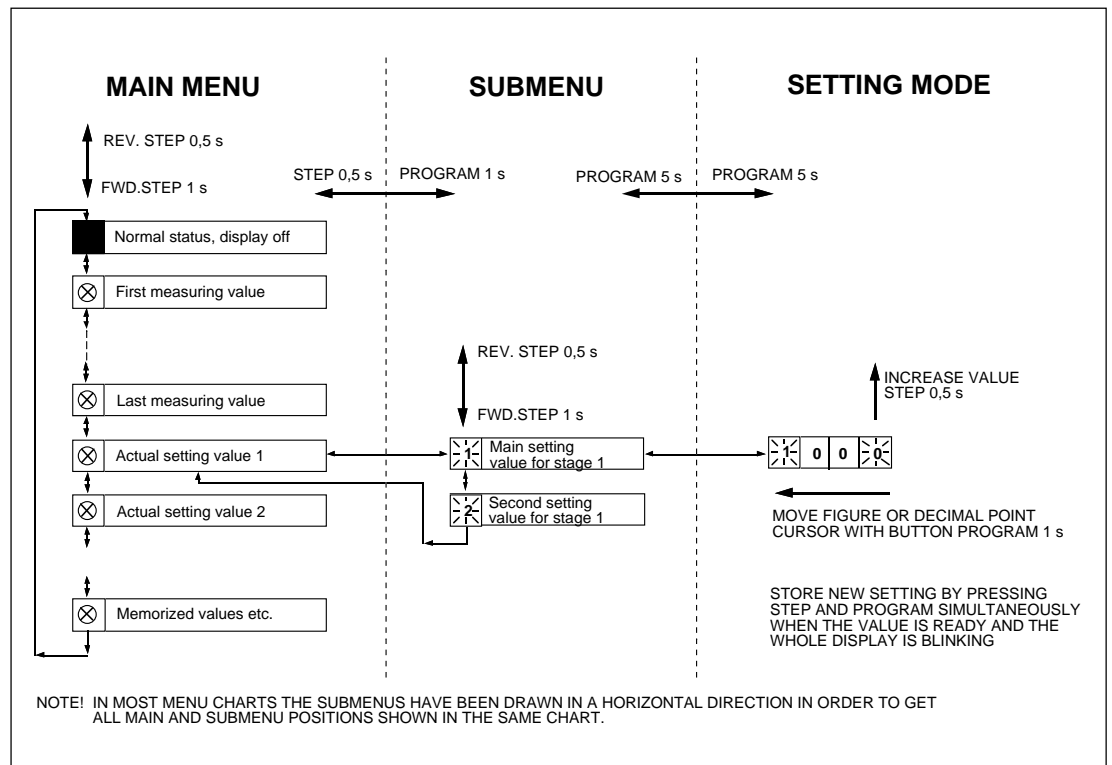

Fig.3. Basic principles of entering the main menus and submenus of a relay module.

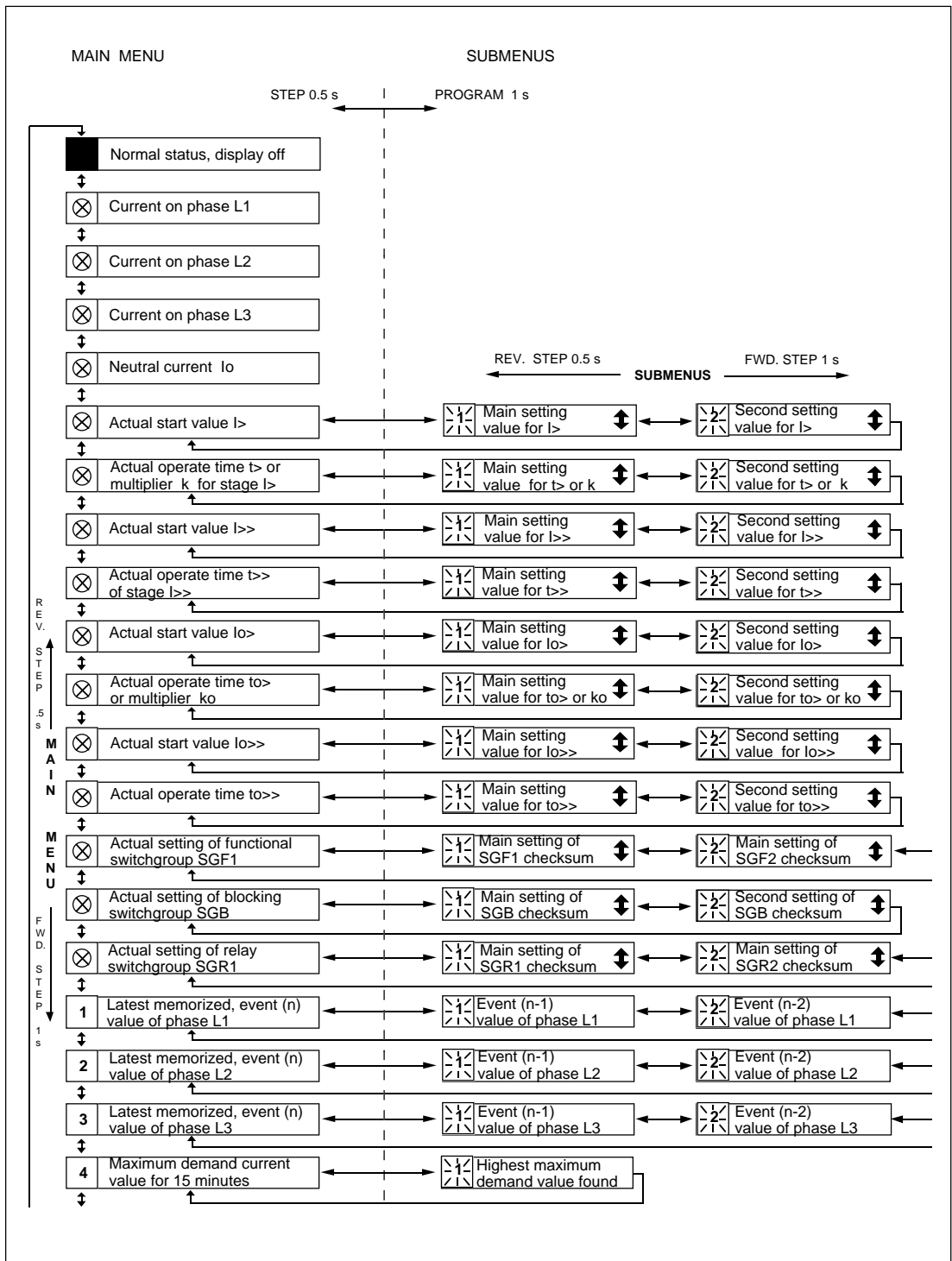

Fig. 4. Example of part of the main and submenus for the settings of the overcurrent and earth-fault relay module SPCJ 4D29. The settings currently in use are in the main menu and they are displayed by pressing the STEP push button. The main menu also includes the measured current values, the registers 1...9, 0 and A. The main and second setting values are located in the submenus and are called up on the display with the PROGRAM push button.

Example 1

Operation in the setting mode. Manual setting of the main setting of the start current value $I>$ of an overcurrent relay module. The initial value

for the main setting is $0.80 \times I_n$ and for the second setting $1.00 \times I_n$. The desired main start value is $1.05 \times I_n$.

a) Press push button STEP repeatedly until the LED close to the $I>$ symbol is lit and the current start value appears on the display.

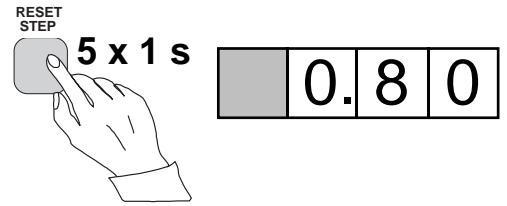

b) Enter the submenu to get the main setting value by pressing the PROGRAM push button more than one second and then releasing it. The red display digit now shows a flashing number 1, indicating the first submenu position and the green digits show the set value.

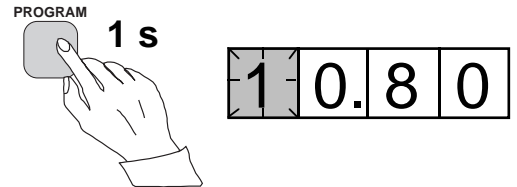

c) Enter the setting mode by pressing the PROGRAM push button for five seconds until the display starts flashing.

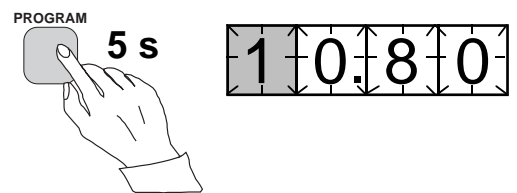

d) Press the PROGRAM push button once again for one second to get the rightmost digit flashing.

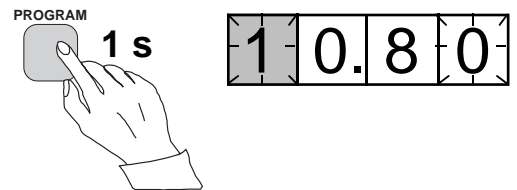

e) Now the flashing digit can be altered. Use the STEP push button to set the digit to the desired value.

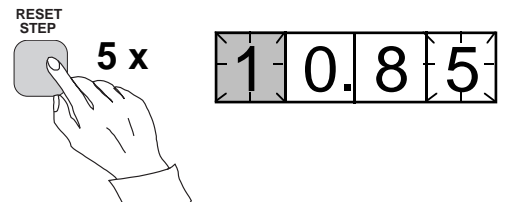

f) Press the PROGRAM push button to make the middle one of the green digits flash.

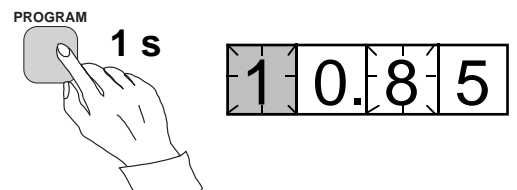

g) Set the middle digit with of the STEP push button.

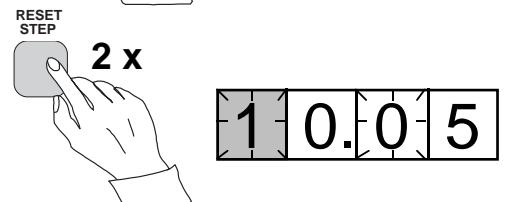

h) Press the PROGRAM push button to make the leftmost green digit flash.

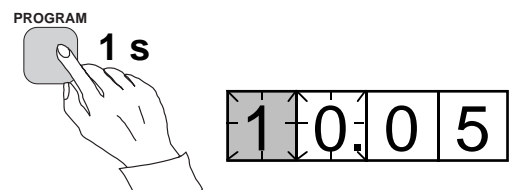

i) Set the digit with the STEP push button.

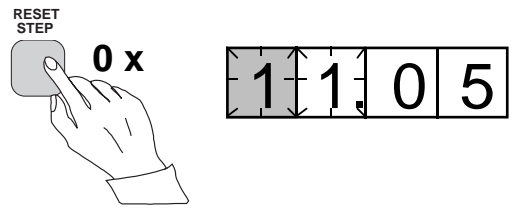

j) Press the PROGRAM push button to make the decimal point flash.

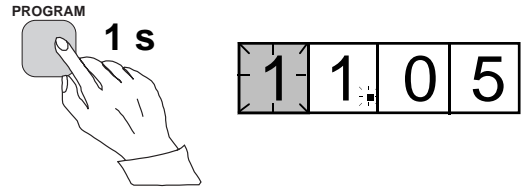

k) If needed, move the decimal point with the STEP push button.

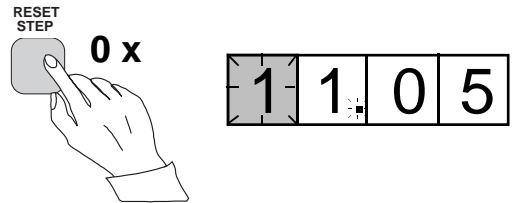

l) Press the PROGRAM push button to make the whole display flash. In this position, corresponding to position c) above, one can see the new value before it is recorded. If the value needs changing, use the PROGRAM push button to alter the value.

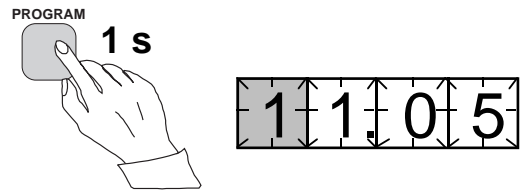

m) When the new value has been corrected, record it in the memory of the relay module by pressing the PROGRAM and STEP push buttons simultaneously. At the moment the information enters the memory, the green dashes flash once in the display, i.e. 1 - - -.

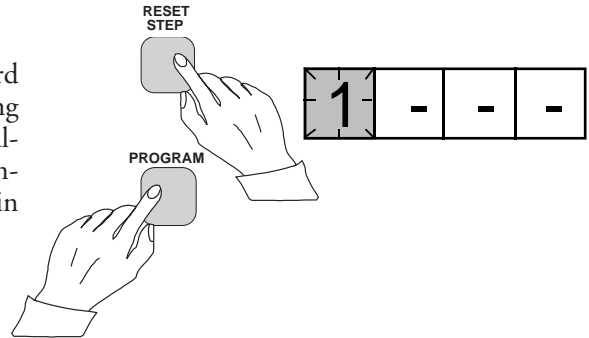

n) Recording of the new value automatically initiates a return from the setting mode to the normal submenu. Without recording one can leave the setting mode any time by pressing the PROGRAM push button for about five seconds, until the green display digits stop flashing.

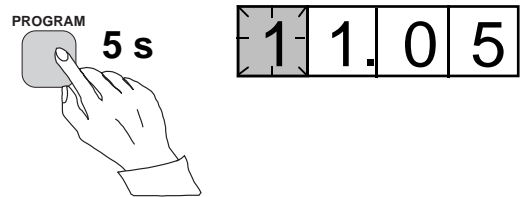

o) If the second setting is to be altered, enter submenu position 2 of the setting I> by pressing the STEP push button for approx. one second. The flashing position indicator 1 will then be replaced by a flashing number 2 which indicates that the setting shown on the display is the second setting for I>.

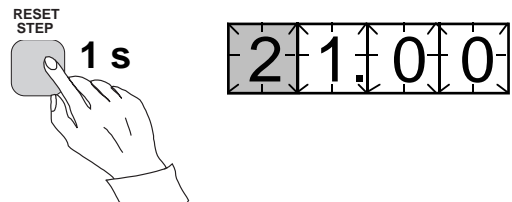

Enter the setting mode as in step c) and proceed in the same way. After recording of the requested values return to the main menu is obtained by pressing the STEP push button

until the first digit is switched off. The LED still shows that one is in the I> position and the display shows the new setting value currently in use by the relay module.

Example 2

Operation in the setting mode. Manual setting of the main setting of the checksum for the switchgroup SGF1 of a relay module. The initial value for the checksum is 000 and the switches

SGF1/1 and SGF1/3 are to be set in position 1. This means that a checksum of 005 should be the final result.

a) Press push button STEP until the LED close to the SGF symbol is lit and the checksum appears on the display.

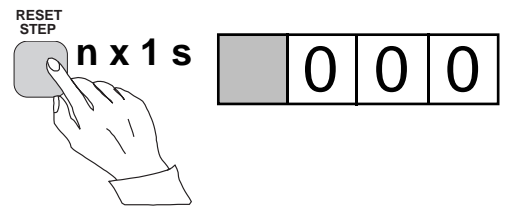

b) Enter the submenu to get the main checksum of SGF1 by pressing the PROGRAM push button for more than one second and then releasing it. The red display now shows a flashing number 1 indicating the first submenu position and the green digits show the checksum.

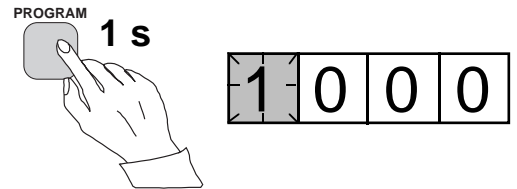

c) Enter the setting mode by pressing the PROGRAM push button for five seconds until the display starts flashing.

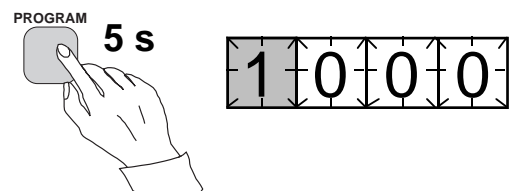

d) Press the PROGRAM push button once again to get the first switch position. The first digit of the display now shows the switch number. The position of the switch is shown by the rightmost digit.

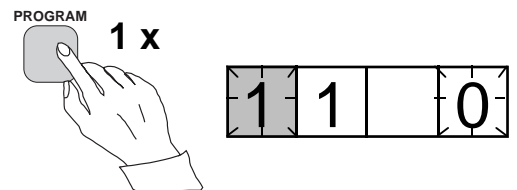

e) The switch position can now be toggled between 1 and 0 by means of the STEP push button and it is left in the requested position 1.

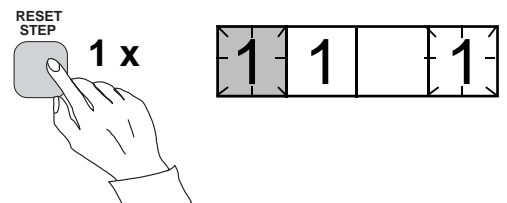

f) When switch number 1 is in the requested position, switch number 2 is called up by pressing the PROGRAM push button for one second. As in step e), the switch position can be altered by using the STEP push button. As the desired setting for SGF1/2 is 0 the switch is left in the 0 position.

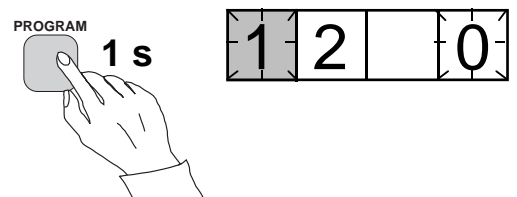

g) Switch SGF1/3 is called up as in step f) by pressing the PROGRAM push button for about one second.

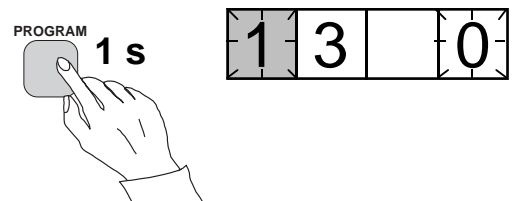

h)
The switch position is altered to the desired position 1 by pressing the STEP push button once.

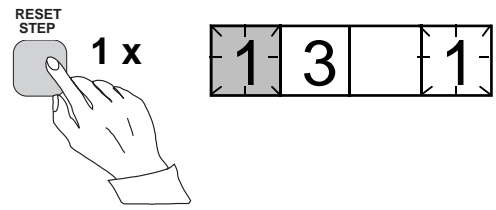

i)
Using the same procedure the switches SGF 1/4...8 are called up and, according to the example, left in position 0.

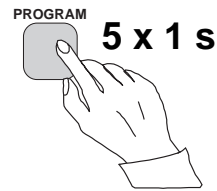

j)
In the final setting mode position, corresponding to step c), the checksum based on the set switch positions is shown.

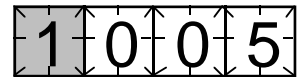

k)
If the correct checksum has been obtained, it is recorded in the memory by pressing the push buttons PROGRAM and STEP simultaneously. At the moment the information enters the memory, the green dashes flash in the display, i.e. 1 - - -. If the checksum is incorrect, the setting of the separate switches is repeated using the PROGRAM and STEP push buttons starting from step d).

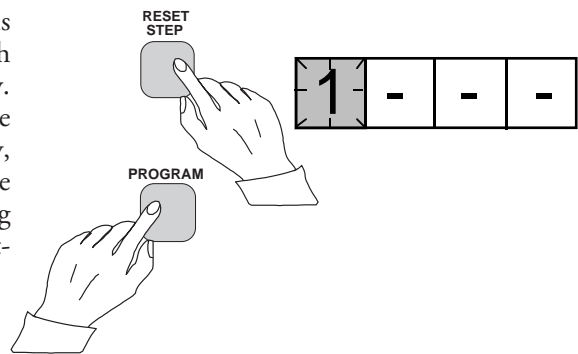

l)
Recording the new value automatically initiates a return from the setting mode to the normal menu. Without recording one can leave the setting mode any time by pressing the PROGRAM push button for about five seconds, until the green display digits stop flashing.

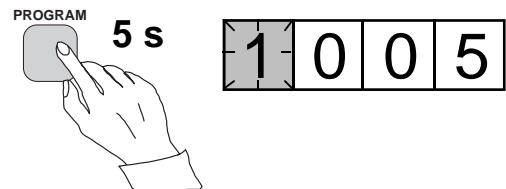

m)
After recording the desired values return to the main menu is obtained by pressing the STEP push button until the first digit is turned off. The LED indicator SGF still shows that one is in the SGF position and that the display shows the new checksum for SGF1 currently in use by the relay module.

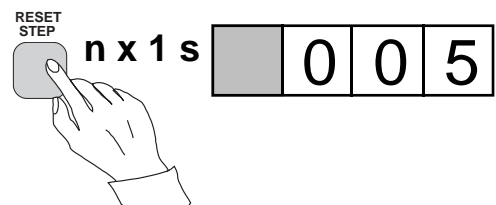

Recorded information

The parameter values measured at the moment when a fault occurs or at the trip instant are recorded in the registers. The recorded data, except for some parameters, are set to zero by pressing the push buttons STEP and PROGRAM simultaneously. The data in normal registers are erased if the auxiliary voltage supply to the relay is interrupted, only the set values and certain other essential parameters are maintained in non-volatile registers during a voltage failure.

The number of registers varies with different relay module types. The functions of the registers are illustrated in the descriptions of the different relay modules. Additionally, the system front panel of the relay contains a simplified list of the data recorded by the various relay modules of the protection relay.

All D type relay modules are provided with two general registers: register 0 and register A.

Register 0 contains, in coded form, the information about e.g. external blocking signals, status information and other signals. The codes are explained in the manuals of the different relay modules.

Register A contains the address code of the relay modul which is required by the serial communication system.

Submenu 1 of register A contains the data transfer rate value, expressed in kilobaud, of the serial communication.

Submenu 2 of register A contains a bus communication monitor for the SPAbus. If the protection relay, which contains the relay module, is linked to a system including a control data communicatoe, for instance SRIO 1000M and the data communication system is operating, the counter reading of the monitor will be zero. Otherwise the digits 1...255 are continuously scrolling in the monitor.

Submenu 3 contains the password required for changing the remote settings. The address code, the data transfer rate of the serial communication and the password can be set manually or via the serial communication bus. For manual setting see example 1.

The default value is 001 for the address code, 9.6 kilobaud for the data transfer rate and 001 for the password.

In order to secure the setting values, all settings are recorded in two separate memory banks within the non-volatile memory. Each bank is complete with its own checksum test to verify the condition of the memory contents. If, for some reason, the contents of one bank is disturbed, all settings are taken from the other bank and the contents from here is transferred to the faulty memory region, all while the relay is in full operation condition. If both memory banks are simultaneously damaged the relay will be set out of operation, and an alarm signal will be given over the serial port and the IRF output relay

Trip test function

Register 0 also provides access to a trip test function, which allows the output signals of the relay module to be activated one by one. If the auxiliary relay module of the protection assembly is in place, the auxiliary relays then will operate one by one during the testing.

When pressing the PROGRAM push button for about five seconds, the green digits to the right start flashing indicating that the relay module is in the test position. The indicators of the settings indicate by flashing which output signal can be activated. The required output function is selected by pressing the PROGRAM push button for about one second.

The indicators of the setting quantities refer to the following output signals:

Setting I>	Starting of stage I>
Setting t>	Tripping of stage I>
Setting I>>	Starting of stage I>>
Setting t>>	Tripping of stage I>>
etc.	
No indication	Self-supervision IRF

The selected starting or tripping is activated by simultaneous pressing of the push buttons STEP and PROGRAM. The signal remains activated as long as the two push buttons are pressed. The effect on the output relays depends on the configuration of the output relay matrix switches.

The self-supervision output is activated by pressing the STEP push button 1 second when no setting indicator is flashing. The IRF output is activated in about 1 second after pressing of the STEP push button.

The signals are selected in the order illustrated in Fig. 4.

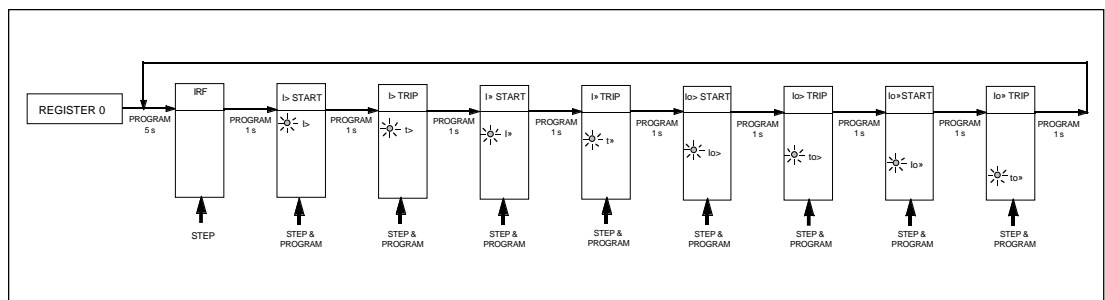

Fig. 5. Sequence order for the selection of output signals in the Trip test mode

If, for instance, the indicator of the setting t> is flashing, and the push buttons STEP and PROGRAM are being pressed, the trip signal from the low-set overcurrent stage is activated. Return to the main menu is possible at any stage of the trip test sequence scheme, by pressing the PROGRAM push button for about five seconds.

Note!

The effect on the output relays then depends on the configuration of the output relay matrix switchgroups SGR 1...3.

Example 3

Trip test function. Forced activation of the outputs.

- a)
Step forward on the display to register 0.

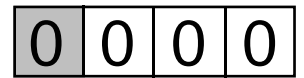
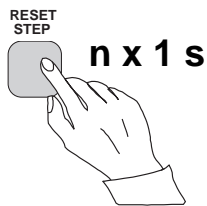

- b)
Press the PROGRAM push button for about five seconds until the three green digits to the right.

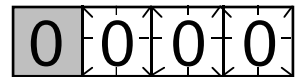
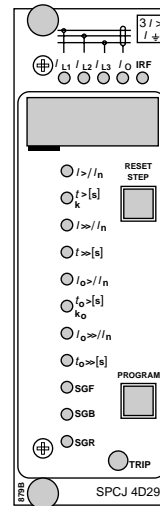

- c)
Hold down the STEP push button. After one second the red IRF indicator is lit and the IRF output is activated. When the step push button is released the IRF indicator is switched off and the IRF output resets.

- d)
Press the PROGRAM push button for one second and the indicator of the topmost setting start flashing.

- e)
If a start of the first stage is required, now press the push-buttons PROGRAM and STEP simultaneously. The stage output will be activated and the output relays will operate according to the actual programming of the relay output switchgroups SGR.

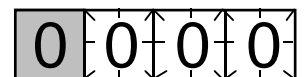
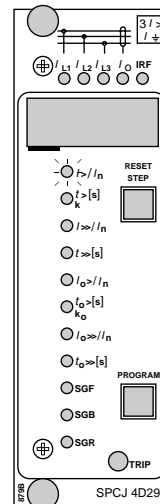
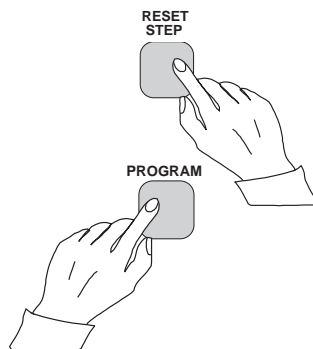

f)
To proceed to the next position press the PROGRAM push button for about 1 second until the indicator of the second setting starts flashing.

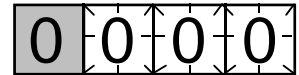
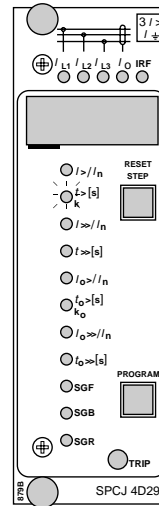

g)
Press the push buttons PROGRAM and STEP simultaneously to activate tripping of stage 1 (e.g. the I> stage of the overcurrent module SPCJ 4D29). The output relays will operate according to the actual programming of the relay switchgroups SGR. If the main trip relay is operated the trip indicator of the measuring module is lit.

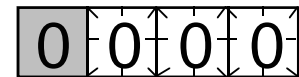
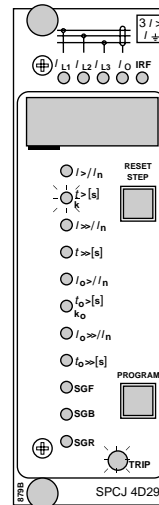
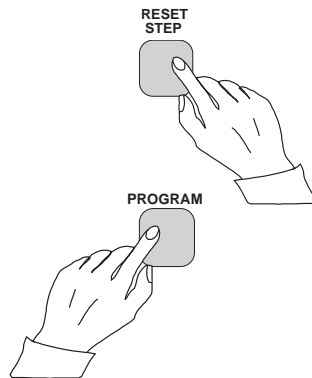

h)
The starting and tripping of the remaining stages are activated in the same way as the first stage above. The indicator of the corresponding setting starts flashing to indicate that the concerned stage can be activated by pressing the STEP and PROGRAM buttons simultaneously. For any forced stage operation, the output relays will respond according to the setting of the relay output switchgroups SGR. Any time a certain stage is selected that is not wanted to operate, pressing the PROGRAM button once more will pass by this position and move to the next one without carrying out any operation of the selected stage.

It is possible to leave the trip test mode at any step of the sequence scheme by pressing the PROGRAM push button for about five seconds until the three digits to the right stop flashing.

Operation indication

A relay module is provided with a multiple of separate operation stages, each with its own operation indicator shown on the display and a common trip indicator on the lower part of the front plate of the relay module.

The starting of a relay stage is indicated with one number which changes to another number when the stage operates. The indicator remains glowing although the operation stage resets. The

indicator is reset by means of the RESET push button of the relay module. An unreset operation indicator does not affect the function of the protection relay module.

In certain cases the function of the operation indicators may deviate from the above principles. This is described in detail in the descriptions of the separate modules.

Fault codes

In addition to the protection functions the relay module is provided with a self-supervision system which continuously supervises the function of the microprocessor, its program execution and the electronics.

Shortly after the self-supervision system detects a permanent fault in the relay module, the red IRF indicator on the front panel is lit. At the same time the module puts forward a control signal to the output relay of the self-supervision system of the protection relay.

In most fault situations a fault code, indicating the nature of the fault, appears on the display of

the module. The fault code, which consists of a red figure "1" and a three digit green code number, cannot be removed from the display by resetting. When a fault occurs, the fault code should be recorded and stated when service is ordered. When in a fault mode, the normal relay menus are operative, i.e. all setting values and measured values can be accessed although the relay operation is inhibited. The serial communication is also operative making it possible to access the relay information also from a remote site. The internal relay fault code shown on the display remains active until the internal fault possibly disappears and can also be remotely read out as variable V 169.



ABB Oy

Substation Automation

P.O.Box 699

FIN-65101 VAASA

Finland

Tel. +358 (0)10 22 11

Fax.+358 (0)10 22 41094

www.abb.com/substationautomation