



Relion® 615 series

Voltage protection and control REU615

Compact and versatile solution for utility and industrial power distribution systems

REU615 is available in two predefined, off-the-shelf configurations, denoted A and B, targeted for two of the most common applications of the IED. The A configuration of REU615 is pre-adapted for voltage and frequency based protection applications in utility and industrial power systems and distribution systems including networks with distributed power generation. The B configuration is pre-adapted for automatic voltage regulation. Both configurations also allow CB control and provide measuring and supervising functions.

REU615 is a member of ABB's Relion® protection and control product family and its 615 product series. The 615 series IEDs are characterized by their compactness and withdrawable-unit design. Re-engineered from the ground up, the new 615 series has been designed to unleash the full potential of the IEC 61850 standard for communication and interoperability between substation automation devices.

Application

The A configuration of REU615 is intended to be used in medium voltage switchgear systems with a separate voltage measuring cubicle. The A configuration of REU615 provides busbar overvoltage and undervoltage supervision, network residual voltage and frequency supervision. REU615 also offers the functionality needed to provide load shedding and generation rejection in order to enhance network stability in situations of excessive load. In generator and motor applications REU615 provides additional protection by supervising frequency and voltage. An integrated synchro-check function ensures a safe connection of a rotating machine to the network. In distribution networks with distributed power generation REU615 can be used for loss-of-mains (LOM) protection for single power generation units.

The B configuration of REU615 featuring voltage regulation capability is targeted for automatic and manual voltage regulation of power transformers equipped with a motor driven on-load tap-changer. In small substations with a single power transformer REU615 can be used for load-side voltage regulation. For substations with two or more power transformers operating in parallel three alternative voltage regulation methods are selectable, i.e. the master/follower principle, the negative reactance principle (NRP) or the minimizing circulating current (MCC) principle.

Protection and control

The A configuration of REU615 features residual overvoltage protection, three-phase overvoltage protection, three-phase undervoltage protection, positive sequence undervoltage protection, negative sequence overvoltage protection and

frequency protection with 6 stages. Further, REU615 incorporates load shedding functionality with 5 stages. REU615 also features network restoration functionality, which ensures that the disconnected loads are reconnected as soon as possible after network recovery to reduce outage times for customers. Using GOOSE messaging or hardwired signaling, also load shedding (disconnection) and restoration (reconnection) functions can be used to control the circuit breakers of up to five sheddable loads. Enhanced with optional hardware and software, REU615 also features three light detection channels for arc detection in the metering cubicle or busbar compartment of metal-enclosed switchgear.

The B configuration of REU615 featuring voltage regulation capability also offers a set of integrated protection functions including three-phase non-directional overcurrent, three-phase undervoltage, three-phase overvoltage and three-phase thermal overload protection for power transformers. Furthermore, REU615 can accommodate an optional multipurpose RTD/mA measurement card. The card can, for instance, be used to extend the functionality of the thermal protection in power transformer applications. It can also act as an interfacing unit for the tap-changer position indication function using direct resistance or mA measurement.

REU615 also integrates functionality for the control of one circuit breaker via the front panel HMI or by means of remote control. The A configuration also offers a synchro-check function. The synchro-check function allows a circuit breaker to be closed only if the voltages on both sides of the circuit breaker fulfill the defined conditions regarding magnitude, phase and frequency difference. The B configuration also supports position indication for the HV side CB and the tap changer.

The signal configuration of the IED can be adjusted using the signal matrix functionality (SMT) or the optional graphical application configuration functionality (ACT) of PCM600, ABB's Protection and Control IED Manager. ACT supports creation of multi-layer logic functions made up of logic elements also including timers and flip-flops. By combining protection functions with logic functions the standard IED configuration can be fine tuned to fit the special requirements of the application.

Standardized communication

REU615 features genuine support for the new IEC 61850 standard for inter-device communication in substations. It also supports the DNP3 and the IEC 60870-5-103 protocol, as also the industry standard Modbus® protocol. For increased communication availability and reliability the IED offers an optional second and third Ethernet network

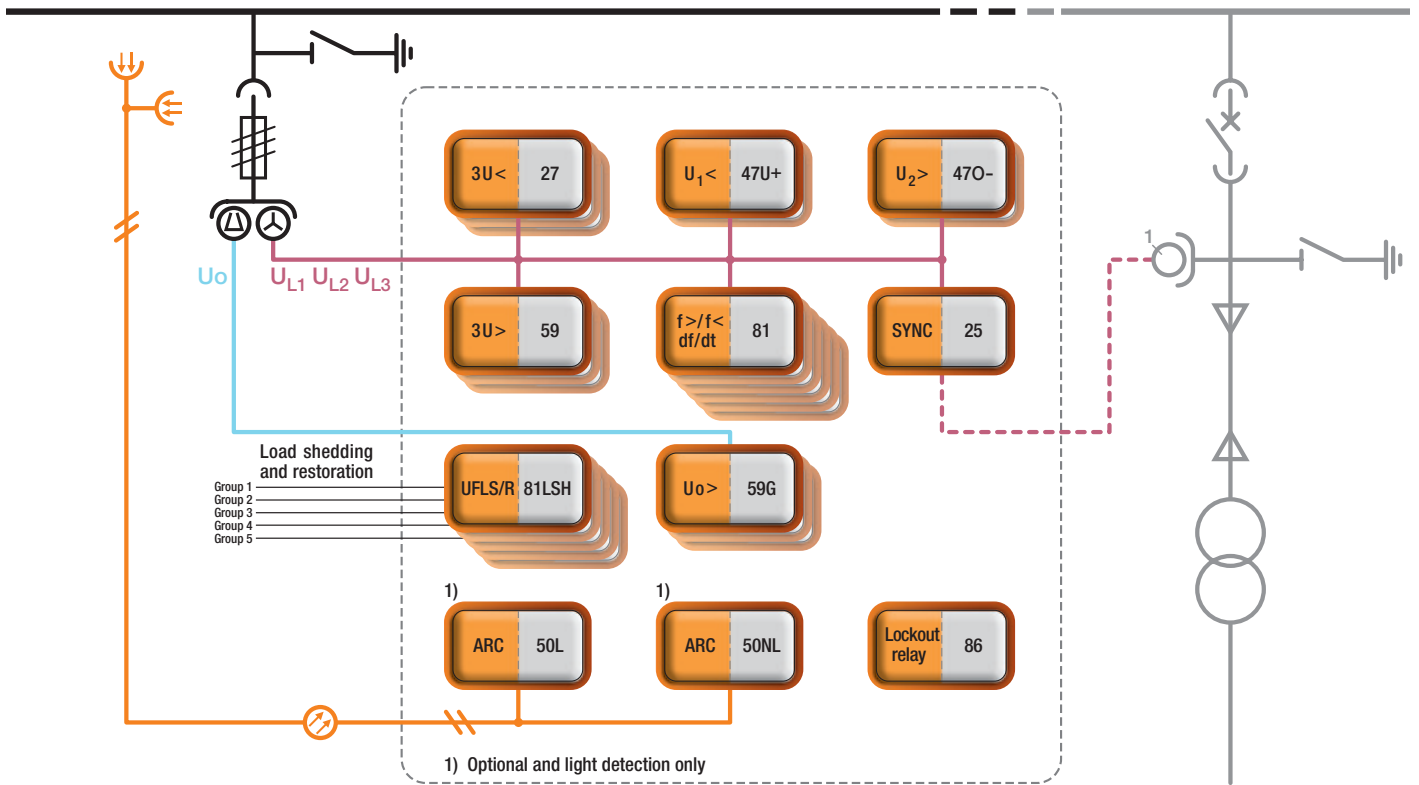

Protection function overview of the A configuration.

interface. The self-healing Ethernet solution constitutes a cost efficient communication loop controlled by a managed switch. The managed switch controls the consistency of the loop, routes the data and corrects the flow of data in communication disturbance situations. The self-healing Ethernet ring can be built on the Ethernet based IEC 61850, Modbus® and DNP3 protocols.

The implementation of the IEC 61850 substation communication standard in REU615 covers both vertical and horizontal communication, including GOOSE messaging with both binary and analog signals and parameter setting

according to IEC 61850-8-1. For accurate time stamping REU615 supports synchronization over Ethernet using SNTP or over a separate bus using IRIG-B.

Single line diagram

The 615 series IEDs with large graphical display offer customizable single line mimic diagrams (SLD) with position indication for the switching devices. The IED can also display measured values provided by the chosen standard configuration. The SLD is also available via the web-browser based HMI. The default SLD can be modified according to user needs using the graphical display editor of PCM600.

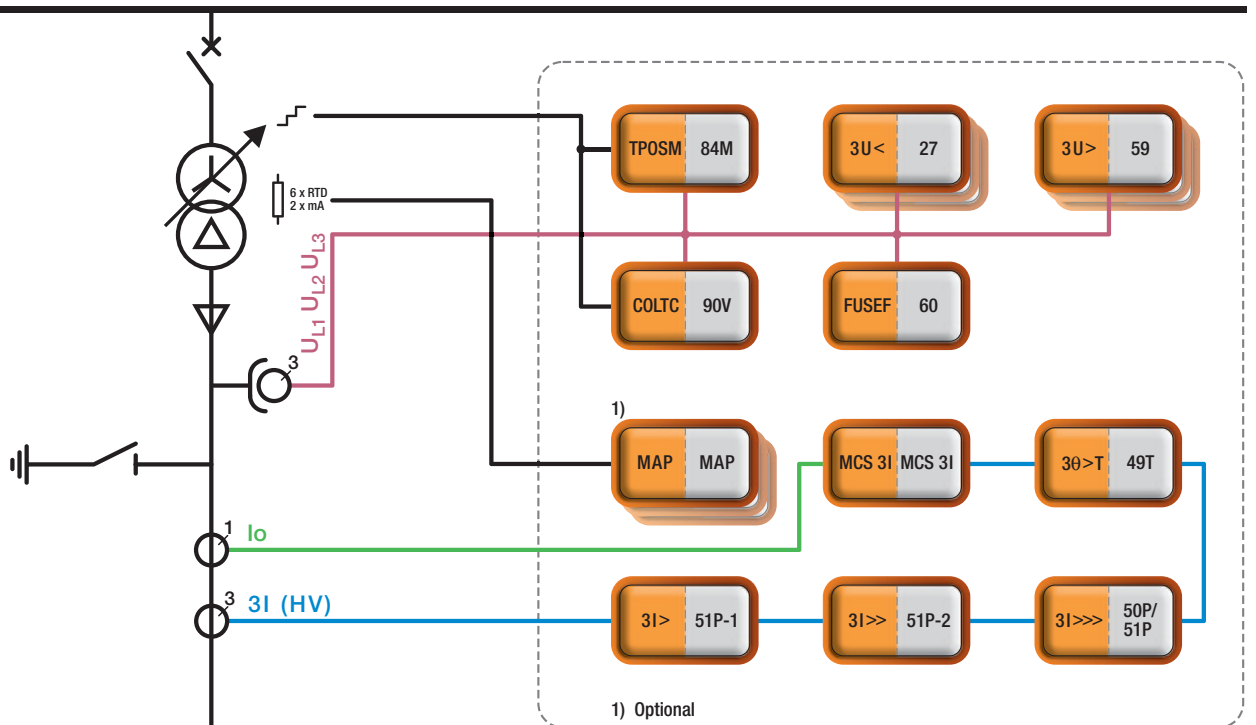

Protection function overview of the B configuration.

Standard configurations

Standard configurations

Description	Standard configuration
Voltage and frequency based protection and measurement functions, synchro-check and load shedding	A
Automatic voltage regulator	B

• = included, o = optional

Supported functions, codes and symbols

Functionality	IEC 61850	IEC 60617	ANSI	A	B
Protection					
Three-phase non-directional overcurrent protection, low stage, instance 1	PHLPTOC1	3I> (1)	51P-1 (1)	-	•
Three-phase non-directional overcurrent protection, high stage, instance 1	PHHPTOC1	3I>> (1)	51P-2 (1)	-	•
Three-phase non-directional overcurrent protection, instantaneous stage, instance 1	PHIPTOC1	3I>>> (1)	50P/51P (1)	-	•
Residual overvoltage protection, instance 1	ROVPTOV1	Uo> (1)	59G (1)	• ¹⁾	-
Residual overvoltage protection, instance 2	ROVPTOV2	Uo> (2)	59G (2)	• ¹⁾	-
Residual overvoltage protection, instance 3	ROVPTOV3	Uo> (3)	59G (3)	• ¹⁾	-
Three-phase undervoltage protection, instance 1	PHPTUV1	3U< (1)	27 (1)	•	•
Three-phase undervoltage protection, instance 2	PHPTUV2	3U< (2)	27 (2)	•	•
Three-phase undervoltage protection, instance 3	PHPTUV3	3U< (3)	27 (3)	•	•
Three-phase overvoltage protection, instance 1	PHPTOV1	3U> (1)	59 (1)	•	•
Three-phase overvoltage protection, instance 2	PHPTOV2	3U> (2)	59 (2)	•	•
Three-phase overvoltage protection, instance 3	PHPTOV3	3U> (3)	59 (3)	•	•
Positive-sequence undervoltage protection, instance 1	PSPTUV1	U1< (1)	47U+ (1)	•	-
Positive-sequence undervoltage protection, instance 2	PSPTUV2	U1< (2)	47U+ (2)	•	-
Negative-sequence overvoltage protection, instance 1	NSPTOV1	U2> (1)	47O- (1)	•	-
Negative-sequence overvoltage protection, instance 2	NSPTOV2	U2> (2)	47O- (2)	•	-
Frequency protection, instance 1	FRPFRQ1	f>/f<, df/dt (1)	81 (1)	•	-
Frequency protection, instance 2	FRPFRQ2	f>/f<, df/dt (2)	81 (2)	•	-
Frequency protection, instance 3	FRPFRQ3	f>/f<, df/dt (3)	81 (3)	•	-
Frequency protection, instance 4	FRPFRQ4	f>/f<, df/dt (4)	81 (4)	•	-
Frequency protection, instance 5	FRPFRQ5	f>/f<, df/dt (5)	81 (5)	•	-
Frequency protection, instance 6	FRPFRQ6	f>/f<, df/dt (6)	81 (6)	•	-
Three-phase thermal overload protection for power transformers, two time constants	T2PTR1	3Ith>T	49T	-	•
Master trip, instance 1	TRPPTRC1	Master Trip (1)	94/86 (1)	•	•
Master trip, instance 2	TRPPTRC2	Master Trip (2)	94/86 (2)	•	•
Arc protection, instance 1	ARCSARC1	ARC (1)	50L/50NL (1)	o ²⁾	-
Arc protection, instance 2	ARCSARC2	ARC (2)	50L/50NL (2)	o ²⁾	-
Arc protection, instance 3	ARCSARC3	ARC (3)	50L/50NL (3)	o ²⁾	-
Multi-purpose protection, instance 1 ³⁾	MAPGAPC1	MAP (1)	MAP (1)	-	o
Multi-purpose protection, instance 2 ³⁾	MAPGAPC2	MAP (2)	MAP (2)	-	o
Multi-purpose protection, instance 3 ³⁾	MAPGAPC3	MAP (3)	MAP (3)	-	o

Supported functions, codes and symbols					
Functionality	IEC 61850	IEC 60617	ANSI	A	B
Protection					
Load shedding and restoration, instance 1	LSHDPFRQ1	UFLS/R (1)	81LSH (1)	•	-
Load shedding and restoration, instance 2	LSHDPFRQ2	UFLS/R (2)	81LSH (2)	•	-
Load shedding and restoration, instance 3	LSHDPFRQ3	UFLS/R (3)	81LSH (3)	•	-
Load shedding and restoration, instance 4	LSHDPFRQ4	UFLS/R (4)	81LSH (4)	•	-
Load shedding and restoration, instance 5	LSHDPFRQ5	UFLS/R (5)	81LSH (5)	•	-
Control					
Circuit-breaker control	CBXCBR1	I ↔ O CB	I ↔ O CB	•	•
Disconnecter position indication, instance 1	DCSXSU1	I ↔ O DC (1)	I ↔ O DC (1)	•	•
Disconnecter position indication, instance 2	DCSXSU2	I ↔ O DC (2)	I ↔ O DC (2)	•	•
Disconnecter position indication, instance 3	DCSXSU3	I ↔ O DC (3)	I ↔ O DC (3)	•	•
Earthing switch indication	ESSXSU1	I ↔ O ES	I ↔ O ES	•	•
Tap changer position indication	TPOSLTC1	TPOSM	84M	-	•
Tap changer control with voltage regulator	OLATCC1	COLTC	90V	-	•
Synchronism and energizing check	SECRSYN1	SYNC	25	•	-
Condition Monitoring					
Trip circuit supervision, instance 1	TCSSCBR1	TCS (1)	TCM (1)	•	•
Trip circuit supervision, instance 2	TCSSCBR2	TCS (2)	TCM (2)	•	•
Current circuit supervision	CCRDIF1	MCS 3I	MCS 3I	-	•
Fuse failure supervision	SEQRFUF1	FUSEF	60	-	•
Measurement					
Disturbance recorder	RDRE1	-	-	•	•
Three-phase current measurement, instance 1	CMMXU1	3I	3I	-	•
Sequence current measurement	CSMSQI1	I1, I2, I0	I1, I2, I0	-	•
Three-phase voltage measurement	VMMXU1	3U	3U	•	•
Residual voltage measurement	RESVMMXU1	Uo	Vn	•	-
Sequence voltage measurement	VSMSQI1	U1, U2, U0	U1, U2, U0	•	•
Three-phase power and energy measurement, including power factor	PEMMXU1	P, E	P, E	-	•
RTD/mA measurement	XRGGIO130	X130 (RTD)	X130 (RTD)	-	o
Frequency measurement	FMMXU1	f	f	•	-

¹⁾ Uo selectable by parameter, Uo measured as default

²⁾ Light only

³⁾ Multi-purpose protection is used for, for example, RTD/mA based protection

The instances of a protection function represent the number of identical function blocks available in a standard configuration. By setting the application specific parameters of an instance, a protection function stage can be established.

Contact us

For more information see REU615 Product Guide
or contact us:

ABB Oy, Distribution Automation

P.O. Box 699
FI-65101 VAASA, Finland
Phone: +358 10 22 11
Fax: +358 10 22 41094

ABB Limited, Distribution Automation

Maneja, Vadodara – 390013, India
Phone: +91 265 260 4386
Fax: +91 265 263 8922

ABB Industrial Park

Torch Hi-tech Industrial Development Zone
Xiamen, Fujian, 361006, P.R.China
Phone: +86 592 570 2288
Fax: +86 592 571 8598

www.abb.com/substationautomation